

BRN48244

AN INVESTIGATION INTO THE PLACEMENT OF PUPILS INTO PRACTICAL AND
ACADEMIC COURSES IN A SELECTED GROUP OF INDIAN SCHOOLS IN THE
GREATER DURBAN AREA

BY

MOGAMBERY NAIDOO
B.A., B.ED., P.T.C.

SUBMITTED IN PART FULFILMENT OF THE REQUIREMENTS
FOR THE DEGREE OF

MASTER OF EDUCATION

IN THE DEPARTMENT OF EMPIRICAL, SPECIAL AND REMEDIAL
EDUCATION IN THE FACULTY OF EDUCATION - UNIVERSITY
OF DURBAN-WESTVILLE

SUPERVISOR: PROF. A.L. BEHR, B.A., B.Sc., B.Sc. (HONS)
M.Ed., D.Ed., U.E.D.
HEAD OF THE DEPARTMENT OF EMPIRICAL,
SPECIAL AND REMEDIAL EDUCATION,
UNIVERSITY OF DURBAN-WESTVILLE.

DURBAN

JANUARY 1979

ACKNOWLEDGEMENT

I wish to express my sincere gratitude to the following people for their assistance and co-operation in making this research project possible.

Prof. A.L. Behr, Head of the Department of Empirical, Special and Remedial Education, University of Durban-Westville, for his thorough and able supervision of this research project. I shall always treasure the encouragement given, the interest shown and the recommendations made by Prof. A.L. Behr;

The Director of Indian Education for his approval of the whole project and permission to use Departmental records;

Dr. N. van der Walt, the Chief Planner for his able encouragement throughout this project;

Mr C.A. Naguran and Mr W.B. Lloyd, Education Planners, for their interest in the project;

Mr R.D. Nobin, my former principal, for the encouragement given;

Mr V. Nair, Principal of Asoka High School, and Mr T. Reddy, Senior Lecturer, Springfield College of Education, for kindly checking the language and making suggestions;

The Principals, teachers and pupils involved in this research for their kind co-operation;

Miss B.C. Greyling for her personal interest in the typing of the manuscript;

Miss V. Nair and Miss T. Nair for proof-reading the final typing;

Finally, my wife and children for the patience shown and encouragement given during the period of this research.

It is hereby declared that the opinions expressed or conclusions reached are those of the writer and are not to be regarded as a reflection of the views of the above mentioned persons.

M. NAIDOO

FEBRUARY 1979

CONTENTS

CHAPTER 1	PAGE
1. EDUCATIONAL MEASUREMENT AND ASSESSMENT AND THE TYPES OF TESTS USED IN INDIAN SCHOOLS	1
1.1 <u>MEASUREMENT AND TESTING IN EDUCATION</u>	1
1.1.1 The relationship between evaluation, measurement and assessment.	1
1.2 <u>TESTS AS MEASURING INSTRUMENTS</u>	2
1.3 <u>TYPES OF TESTS USED IN INDIAN SCHOOLS</u>	2
1.3.1 Routine classroom tests given during the course of the year	2
1.3.2 Tests designed for examinations	3
1.3.2.1 Tests designed for internal promotion examinations	4
1.3.2.2 Tests designed for the external promotion examination	6
1.4 <u>FORMAT OF TESTS USED IN INDIAN SCHOOLS</u>	7
1.4.1 Written tests	7
1.4.1.1 Essay type tests	8
1.4.1.2 The objective type test	14
1.4.1.2.1 Nature of objective type test	15
1.4.1.2.2 Advantages of the objective test	17
1.4.1.2.3 Some disadvantages of the objective type tests	19
1.4.2 Oral tests	20
1.4.3 Practical tests	21
1.5 <u>THE STANDARDISED TESTS USED IN INDIAN SCHOOLS</u>	23
1.6 <u>THE ATTRIBUTES OF A GOOD TEST</u>	25
1.6.1 Reliability	26
1.6.2 Discriminating power	26
1.6.3 Validity	28
REFERENCE	29

CHAPTER 2

2.	THE PROMOTION, PROCEDURES BASED ON ASSESSMENT IN THE INDIAN EDUCATIONAL SYSTEM FOLLOWING THE INTRODUCTION OF DIFFERENTIATED EDUCATION	35
2.1	<u>DIFFERENTIATION IN GENERAL IN SOUTH AFRICA CULMINATING IN I.E. CIRCULAR NO. 28 OF 1972</u>	35
2.2	<u>AN OUTLINE OF THE PROVISIONS OF THE FOUR-PHASE SYSTEM OF SCHOOLING IN INDIAN EDUCATION</u>	37
2.2.1	The junior primary phase	39
2.2.2	The senior primary phase	39
2.2.3	The junior secondary phase	39
2.2.4	The senior secondary phase	40
2.3	<u>CURRICULA, FIELD OF STUDY AND PROMOTION REQUIREMENTS IN THE JUNIOR PRIMARY PHASE</u>	41
2.3.1	Curricula and field of study	41
2.3.2	Promotion in phase one	42
2.4	<u>CURRICULA, FIELD OF STUDY AND PROMOTION REQUIREMENTS IN THE SENIOR PRIMARY PHASE</u>	43
2.4.1	Curricula and field of study	43
2.4.2	Promotion in phase two	45
2.5	<u>CURRICULA, FIELD OF STUDY AND PROMOTION REQUIREMENTS IN THE JUNIOR SECONDARY PHASE</u>	47
2.5.1	Curricula and field of study	47
2.5.2	Promotion requirements in phase three	51
2.6	<u>CURRICULA, FIELD OF STUDY AND PROMOTION REQUIREMENTS IN THE SENIOR SECONDARY PHASE</u>	58
2.6.1	Curricula and field of study	58
2.6.2	Promotion requirements in phase four	67
2.7	<u>AN ASSESSMENT OF THE FOUR-PHASE SYSTEM OF DIFFERENTIATED EDUCATION</u>	71

2.8	<u>AN ANALYSIS OF THE 1977 EXAMINATION RESULTS OF STANDARDS 5, 6 AND 7 ACADEMIC COURSE PUPILS WHO OBTAINED PRACTICAL PASSES</u>	74
2.9	<u>PUPILS WRITING THE ACADEMIC COURSE EXAMINATION AND WHO GAIN PRACTICAL COURSE PASSES</u>	76
2.10	<u>GENERAL</u>	78
	REFERENCE	80
CHAPTER 3		
3.	SOME FACTORS THAT INFLUENCE THE PLACEMENT OF PUPILS INTO THE DIFFERENT TYPES OF SECONDARY SCHOOL COURSES	84
3.1	<u>FACTORS OUTSIDE THE CHILD THAT INFLUENCE PLACEMENT</u>	84
3.1.1	The school curriculum	84
3.1.2	Educational aims and objectives	85
3.1.3	Teacher implications in selection	88
3.1.4	The effects of the school on selection	90
3.1.5	The influence of selection on socially disadvantaged children	91
3.1.6	Educational labelling and its influence on pupils	92
3.2	<u>FACTORS WITHIN THE CHILD THAT INFLUENCE PLACEMENT</u>	93
3.2.1	Intelligence, aptitudes and grouping of pupils	93
3.2.2	Maturation of pupils and its influence on the education of pupils	97
3.2.3	The age of transfer to secondary school courses	97
3.3	<u>THE PROBLEM OF FAILURE AND RELATED MATTERS</u>	98
3.4	<u>THE UNDERACHIEVING CHILD</u>	101
3.5	<u>THE IMPORTANCE OF INTELLIGENCE AND APTITUDE TESTS IN SELECTING PUPILS FOR SECONDARY SCHOOL COURSES</u>	103
3.6	<u>FACTORS TO BE TAKEN INTO CONSIDERATION WHEN PLACING PUPILS INTO THE DIFFERENT TYPES OF SECONDARY SCHOOL COURSES</u>	105
	REFERENCE	108

CHAPTER 4

4.	A STUDY OF THE PLACEMENT OF PUPILS INTO PRACTICAL AND ACADEMIC CLASSES IN FIFTEEN INDIAN SECONDARY SCHOOLS IN THE GREATER DURBAN AREA	116
4.1	<u>THE NATURE OF THE PRESENT STUDY</u>	116
4.2	<u>PROCEDURE IN THE PRESENT STUDY</u>	116
4.2.1	The purpose of the present study	116
4.2.2	The procedure adopted by the Division of Education in constructing tests in English and Mathematics	118
4.2.3	The pilot study	122
4.3	<u>THE MAIN INVESTIGATION</u>	126
4.3.1	Population	126
4.3.2	Schools in the sample	127
4.3.3	Pupils in the sample	129
4.3.4	Methods of data collection	131
4.3.5	Distribution of test papers, marking memoranda and data form	132
4.3.6	Data processing and statistical analysis of results	135
4.3.6.1	Data processing	135
4.3.6.2	Methods of statistically analysing the results	135
4.3.7	The results of the present study	142
4.3.7.1	The Relationship between the performance of academic and practical course pupils in tests administered in English and Mathematics	142
4.3.7.2	The Relationship between the scores obtained by the same pupils in the sample in tests in English and Mathematics	154
4.3.7.3	The Age Factor and its influence on the placement of pupils into practical and academic courses	155
4.3.7.3.1	The Relationship between age of pupils and the course followed in Indian schools	156
4.3.7.3.2	The Relationship between age and performance in tests in English and Mathematics	161

4.3.7.4	Parental occupation and its influence on the placement of pupils into practical and academic courses	163
4.3.7.5	I.Q. and its influence on the placement of pupils into practical and academic courses	168
4.3.7.5.1	The Distribution of pupils according to I.Q. in the academic and practical courses	170
4.3.8	Summary of findings	172
	REFERENCE	174
CHAPTER 5		
5.	GENERAL CONCLUSIONS AND RECOMMENDATIONS	180
5.1	<u>LIMITATIONS OF THE PRESENT STUDY</u>	180
5.2	<u>DISCUSSION OF FINDINGS</u>	181
5.2.1	Performance of pupils in tests in English and Mathematics	182
5.2.2	The influence of age on scholastic achievement	183
5.2.3	Father's occupation as an indicator of socio-economic background of the pupil	184
5.2.4	The Relationship between I.Q. and placement of pupils into practical and academic courses	185
5.3	<u>RECOMMENDATIONS</u>	186
5.3.1	Promotion from one class to the next and selection for academic and practical courses at the end of standards 5, 6 and 7	186
5.3.1.1	Promotion procedures in standards 5, 6 and 7	187
5.3.1.2	The procedure to be followed in selecting pupils for the academic and practical courses	188
5.3.1.3	The use of the various instruments for selection purposes	192
5.3.2	School Guidance Counsellors for Primary Schools	199
5.3.3	Appointment of school social workers	200

5.3.4	Educational Objectives	201
5.3.5	Curriculum Study	201
5.3.6	Establishment of an education research bureau	202
	REFERENCE	203
	SELECTED BIBLIOGRAPHY	207

APPENDICES

APPENDIX

- I ENGLISH AND MATHEMATIC SYLLABUSES FOR STANDARDS
5, 6 AND 7 ACADEMIC COURSE
- II ENGLISH AND MATHEMATICS TEST PAPERS
- III DATA COLLECTION SHEET
- IV COMPUTER PROGRAMME
- V CALCULATION OF CHI-SQUARED (χ^2)
- VI TEACHER'S ASSESSMENT OF PUPIL'S POTENTIAL

LIST OF TABLES

TABLE	DESCRIPTION	
1.1	MARKS AWARDED BY EXAMINERS IN THE FIRST AND SECOND MARKING OF THE ESSAY TYPE ANSWER	10
1.2	CORRELATION COEFFICIENTS AND SIGNIFICANCE LEVELS FOR MARKS OBTAINED BY CANDIDATES IN THE ORAL AND WRITTEN ASPECTS OF AFRIKAANS AND ENGLISH IN THE SENIOR CERTIFICATE EXAMINATION OF 1977	21
1.3	CORRELATION COEFFICIENTS AND SIGNIFICANCE LEVELS IN THE PRACTICAL AND WRITTEN ASPECTS OF A SELECTED NUMBER OF SUBJECTS IN THE SENIOR CERTIFICATE EXAMINATION OF 1977	32
2.1	FLOW CHART SHOWING THE FUNCTIONING OF THE SYSTEM OF DIFFERENTIATED EDUCATION	38
2.2	SUBJECTS AND WEEKLY ALLOCATION OF TIME FOR THE JUNIOR PRIMARY PHASE	41
2.3	TOTAL ENROLMENT, PERCENTAGE PASS AND PERCENTAGE FAILURE FOR 1977 IN PHASE ONE	43
2.4	SUBJECTS AND WEEKLY ALLOCATION OF TIME FOR THE SENIOR PRIMARY PHASE	44
2.5	ENROLMENT, PERCENTAGE PASS AND PERCENTAGE FAILURE IN PHASE TWO IN 1977	46
2.6	SUBJECTS AND WEEKLY ALLOCATION OF TIME FOR THE JUNIOR SECONDARY PHASE (ACADEMIC COURSE)	47
2.7	SUBJECT AND WEEKLY ALLOCATION OF TIME FOR THE PRACTICAL COURSE	50
2.8	PASS REQUIREMENTS IN STANDARDS 6 AND 7 FOR PROMOTION INTO THE NEXT HIGHER CLASS	55
2.9	ENROLMENT, PERCENTAGE PASS AND FAILURE IN PHASE THREE IN 1977	57
2.10	WEEKLY ALLOCATION OF TIME FOR THE SENIOR SECONDARY PHASE - ACADEMIC COURSE	59
2.11	SUBJECTS AND NUMBER OF PUPILS TAKING EACH IN STANDARDS 8, 9 AND 10 IN 1977	60
2.12	SUBJECTS AND WEEKLY TIME ALLOCATION FOR STANDARD EIGHT - PRACTICAL COURSE	63
2.13	WEEKLY ALLOCATION OF TIME FOR SUBJECTS IN STANDARDS 9 AND 10 - PRACTICAL COURSE	64

2.14	NUMBER OF PUPILS TAKING THE VARIOUS SUBJECTS IN STANDARDS 9 PRACTICAL COURSE IN 1978	66
2.15	ENROLMENT, PERCENTAGE PASS AND FAILURE IN PHASE 4 IN INDIAN SCHOOLS IN 1977	70
2.16	PERCENTAGE OF PUPILS WHO ON ENTERING CLASS ONE REACH STANDARD 10	72
2.17	PERCENTAGE OF PUPILS WHO FAILED TO GAIN ACADEMIC PASSES IN SUBJECTS TAKEN FOR THE 1977 EXAMINATIONS	75
2.18	DISTRIBUTION OF ACADEMIC AND PRACTICAL COURSE PUPILS IN STANDARDS 5, 6 AND 7 BASED ON THE SCHOOL EXAMINATION RESULTS OF 1975, 1976 AND 1977	77
2.19	PERCENTAGE OF PUPILS IN THE PRACTICAL COURSE IN STANDARD 6, 7 AND 8 SCHOOL POPULATION FOR THREE YEARS	78
3.1	DISTRIBUTION OF INTELLIGENCE BASED ON THE NEW SOUTH AFRICAN GROUP TEST	94
3.2	FAILURE PER STANDARD IN INDIAN SCHOOLS IN 1977	100
3.3	AVERAGE FAILURE RATES IN INDIAN SCHOOLS FOR THE PERIOD 1966 TO 1970	100
4.1	DISTRIBUTION OF SAMPLE USED IN THE PILOT INVESTIGATION	123
4.2	MEANS AND STANDARD DEVIATIONS OBTAINED IN THE EXTERNAL EXAMINATIONS IN ENGLISH AND MATHEMATICS IN THE PILOT INVESTIGATION	124
4.3	CRITICAL RATIOS AND SIGNIFICANCE LEVELS FOR THE DIFFERENCE OF THE MEAN PERFORMANCE OF ACADEMIC AND PRACTICAL COURSE PUPILS IN ENGLISH AND MATHEMATICS	125
4.4	DISTRIBUTION OF PUPILS IN THE SAMPLE AMONG SCHOOLS	128
4.5	DISTRIBUTION OF PUPILS IN RESPECT OF COURSES IN THE SAMPLE	130
4.6	CALCULATION OF χ^2 IN A TEST OF INDEPENDENCE BETWEEN I.Q. SCORES AND SCORES IN MATHEMATICS	137
4.7	COMPUTING PEARSON'S PRODUCT MOMENT CORRELATION FOR SCORES IN ENGLISH AND MATHEMATICS	139
4.8	MATHEMATICS SCORES OBTAINED BY STANDARD 8 ACADEMIC AND PRACTICAL COURSE PUPILS IN THE SAME TEST	140
4.9	NUMBER AND PERCENTAGE OF PUPILS THAT PASSED OR FAILED TESTS IN ENGLISH AND MATHEMATICS IN EACH STANDARD UNDER STUDY	143

4.10	CHI-SQUARE (χ^2) AND SIGNIFICANCE LEVELS (p) FOR PERFORMANCE (PASS/FAIL) OF ACADEMIC AND PRACTICAL COURSE PUPILS IN TESTS IN MATHEMATICS AND ENGLISH	145
4.11	CRITICAL RATIOS AND SIGNIFICANCE LEVELS FOR MEAN PERFORMANCE OF ACADEMIC AND PRACTICAL COURSE PUPILS IN TESTS IN ENGLISH AND MATHEMATICS	147
4.12	PERCENTAGE AND NUMBER OF PUPILS WHO ARE WRONGLY PLACED IN ACADEMIC AND PRACTICAL COURSES IN THE SAMPLE (BASED ON THE PERFORMANCE OF PUPILS IN TESTS IN ENGLISH AND MATHEMATICS COMBINED)	149
4.13	DIFFERENCE BETWEEN PUPILS IN THE ACADEMIC AND PRACTICAL COURSES WHO PASS BOTH I.E. ENGLISH AND MATHEMATICS	150
4.14	CORRELATION COEFFICIENTS AND THE SIGNIFICANCE LEVELS BETWEEN ENGLISH AND MATHEMATICS SCORES FOR A SAMPLE OF PRACTICAL AND ACADEMIC COURSE PUPILS	154
4.15	DISTRIBUTION OF PUPILS IN THE SAMPLE ACCORDING TO AGE CATEGORIES, STANDARD AND COURSE IN PERCENTAGES	156
4.16	CHI-SQUARES AND SIGNIFICANCE LEVELS BETWEEN AGE AND PUPILS IN THE ACADEMIC AND PRACTICAL COURSES	158
4.17	DISTRIBUTION OF PUPILS IN THE STANDARD 6 ACADEMIC AND PRACTICAL COURSE IN EACH AGE CATEGORY	158
4.18	AGE CATEGORIES IN THE SAMPLE AND THE PERCENTAGE OF PUPILS THAT PASSED IN EACH ACCORDING TO STANDARD AND SUBJECT	161
4.19	CHI-SQUARE AND SIGNIFICANCE LEVEL IN RESPECT OF AGE AND PERFORMANCE IN MATHEMATICS	162
4.20	CHI-SQUARE AND SIGNIFICANCE LEVEL IN RESPECT OF AGE AND PERFORMANCE IN ENGLISH	163
4.21	PERCENTAGE OF FATHERS EITHER DECEASED OR UNEMPLOYED IN THE ACADEMIC AND PRACTICAL COURSES	164
4.22	DISTRIBUTION OF SAMPLE AMONG THE VARIOUS CATEGORIES OF FATHERS' OCCUPATION (PERCENTAGE WISE)	165
4.23	CHI-SQUARED AND SIGNIFICANCE LEVEL FOR FATHERS' OCCUPATION AND PUPILS PLACED INTO PRACTICAL AND ACADEMIC COURSES IN THE SAMPLE	166
4.24	DISTRIBUTION OF PUPILS ACCORDING TO I.Q. IN STANDARD 7 AND 8, ACADEMIC AND PRACTICAL COURSES, IN PERCENTAGE	169
4.25	CHI-SQUARED AND SIGNIFICANCE LEVELS FOR PUPILS PLACED INTO PRACTICAL AND ACADEMIC COURSES IN STANDARDS 7 AND 8	171

LISTS OF GRAPHS

1.	PERCENTAGE OF PUPILS WHO ON ENTERING CLASS ONE IN 1966 REACHED STANDARD 10 IN 1977	73
2.	PASSES IN THE MATHEMATICS TEST IN STANDARDS 6, 7 AND 8 PRACTICAL AND ACADEMIC COURSES ACCORDING TO SEX	152
3.	PASSES IN THE ENGLISH TEST IN STANDARDS 6, 7 AND 8 PRACTICAL AND ACADEMIC COURSES ACCORDING TO SEX	153

CHAPTER 11. EDUCATIONAL MEASUREMENT AND ASSESSMENT AND THE TYPES OF TESTS USED IN INDIAN SCHOOLS1.1 MEASUREMENT AND TESTING IN EDUCATION1.1.1 The relationship between evaluation, measurement and assessment

A clear distinction between evaluation, measurement and assessment needs to be drawn. Ebel (1974) contends that evaluation follows upon measurement and the consideration of other sources of information of a pupil. ⁽¹⁾ Huberman (1973), ⁽²⁾ Schofield (1974), ⁽³⁾ Montgomery (1965) ⁽⁴⁾ and Davis (1966) ⁽⁵⁾ confirm the view of Ebel that measurement is a prerequisite to evaluation.

Richmond (1975) holds a view different from that of Ebel. For him measurement (as for example, awarding a pupil 9 out of 10 marks for an essay) is quantitative appraisal; evaluation on the other hand (as, for example, designating the pupil's essay as "very good") is qualitative appraisal. Both are highly subjective. He, therefore, prefers the concept assessment which represents a combination of both measurement and evaluation. ⁽⁶⁾

A perusal of the views of several other authorities i.e. van der Walt (1974), ⁽⁷⁾ Niven (1977), ⁽⁸⁾ Behr (1971), ⁽⁹⁾ Craig (1973), ⁽¹⁰⁾ Jooste (1974) ⁽¹¹⁾ and Loret (1975) ⁽¹²⁾ confirms the view of Richmond.

The view taken by the writer is that assessment and evaluation are closely linked. Therefore no clear-cut distinction between assessment and evaluation is drawn. In the context of this work only the word "assessment" will be used. The word assessment will imply evaluation as well. However, since measurement lies at the root of evaluation and assessment, attention will be given to measuring instruments.



1.2 TESTS AS MEASURING INSTRUMENTS

One of the most important measuring instruments used in education is a test. Kerlinger (1972) defines a test as a systematic procedure in which the testee "is presented with a set constructed stimuli to which he responds, the responses enabling the tester to assign the testee a numeral or set of numerals from which inferences can be made about the testee's possession of whatever the test is supposed to measure". (13)

Coulter (1974) states that a test is a measuring instrument and as such it serves to convert a behavioural or mental activity into a numeric value. In order to be a good measuring instrument, the test must be selective, accurate and sensitive. (14) According to Behr (1973), the purpose of a test is to discover, what a person can do, and the usual method is to get him to answer questions or perform tasks, and then assess the degree of success with which he does so. (15)

The writer takes the view that a test can be used not only to measure a pupil's present performance, but also to predict future performance in a particular field of study.

1.3 TYPES OF TESTS USED IN INDIAN SCHOOLS

1.3.1 Routine classroom tests given during the course of the year

The Department of Indian Affairs does not lay down any set procedure that has to be followed in its schools in respect of tests and testing. In some schools the Principals may lay down the minimum number of tests that may be set, administered and marked by teachers during the school year. In most instances the teacher decides when a test should be given to pupils under his care.

Routine classroom tests are short and are normally constructed for the duration of half-an-hour. The test items may comprise essays, objective type questions or a combination of both.

A test administered at the beginning of the school year, serves to give the teacher insight into what knowledge, skills, and understanding the pupil has at the outset of his course. These tests are normally referred to as pretests. Ideally the programme of study for each pupil should be planned on the basis of his pre-test scores and other relevant information about him.

Periodically during the year the teacher administers short tests for a variety of purposes. These tests are referred to as class tests. Class tests may be administered to determine the extent to which pupils have learned the subject matter taught. Most tests used for this purpose are constructed by the teacher to cover specific knowledge, skills and understanding that have been taught. Class-tests can also be used to compare the achievements of an individual pupil with the achievement levels of pupils in his own class. They may also be used for diagnostic and remedial purposes. In many schools class tests are also used to estimate a pupil's potential or aptitude for learning a subject or for ability grouping within that subject.

1.3.2 Tests designed for examinations

In Indian schools specially designed tests in a number of subjects are written during specified times, normally towards the end of the first half of the year and the end of the year. These tests are used for promotion of pupils from one standard to the next. Such tests are referred to as examinations. In Indian schools two types of examinations are held i.e. internal and external examinations. (16)

1.3.2.1 Tests designed for internal promotion examinations

The Department of Indian Affairs lays down the procedure to be followed by schools in respect of the internal promotion examination. The Department stipulates that there must be two examinations for pupils from standards 3 to 9. One is to be written in June and the other in November/December of the same school year. The mark allocation for the June and November/December examinations is also stipulated. ⁽¹⁷⁾ The principles governing the conducting and administering of the internal examination are broadly stated. This enables schools to fashion the internal examination according to the conditions at the school.

Test papers for the examinations are set, administered and marked internally at schools. Generally at the beginning of a school year teachers are presented with a memorandum on examinations. The memorandum reflects the total marks for the June and November examinations, the total marks to be allocated to the various subjects in the different standards, the pass mark in each subject or group of subjects and the pass mark in the aggregate. In some schools, instead of presenting teachers with an examination memorandum, principals inform teachers of the examination requirements at a staff meeting. Teachers are required to take note of those aspects that concern them.

A month or so before each examination the Principal delegates to certain teachers the responsibility of setting the examination papers in certain subjects. Teachers teaching the subject are normally chosen to set question papers in that subject. Teachers setting the question papers must also prepare detailed marking memoranda. The marking memoranda

reflect the marks for the various sections and also the expected answers.

The test items normally set by teachers include the essay and objective type questions. Once the papers are set they are moderated by the senior subject teacher. The moderator ensures that the test items are within the prescribed syllabus and the content of the syllabus is adequately covered. Pupils are timeously informed about the examination arrangements. They are issued with examination time-tables in which are indicated the time and date when a particular subject is to be written. Pupils present themselves for the examination papers as set out on their time-tables.

Once the papers are written, the principal distributes the marking among the subject teachers. Generally each teacher is given a copy of the marking memorandum. After the marking is completed the scripts are moderated by a senior subject teacher. The scripts are then handed to the class or form teacher who enters the marks into the class mark book.

It must be noted that pupils are allocated marks for oral and practical work in certain subjects only. These marks are allocated during normal teaching time. Marks obtained by pupils in orals and practicals are also entered in the mark book.

On the basis of the marks obtained by pupils in the orals, practical and written examination, pupils are either failed or promoted to the next standard. Promotion is based on a combination of the marks obtained in both the June and November examinations. (18)

1.3.2.2 Tests designed for the external promotion examination

The only external examination written by pupils in schools under the control of the Division of Education of the Department of Indian Affairs is the Senior Certificate Examination. The Senior Certificate Examination is written by pupils at the end of the standard 10 course. The examination is written in November/December of any school year. (19)

In August, Principals of schools inform the Department of the names of candidates that have entered for the examination, the subjects to be offered and the grade at which these are offered. (20) The Department sends time-tables to each candidate indicating the date and time when the various subjects are to be written. (21) The Principal of each school is the chief invigilator and he appoints teachers from his staff as invigilators. (22)

By and large the question papers are set by a panel of three examiners, appointed by the Department of Indian Affairs. These examiners may be employed by the Department of Indian Affairs or by any other education department in this country. The panel of three examiners generally sets four question papers i two Higher Grades and two Standard Grades in the same subject. The examiners also prepare the marking memoranda for all the question papers. One Higher and one Standard Grade papers are for the November/December examination and the other Higher and Standard Grade papers are for the supplementary examination, held in February/March of the following year. The examiners are paid by the Department for the setting of question papers. (23)

Once the question papers are set they are edited by the professional examinations officer of the Department, and thereafter submitted to the Joint Matriculation Board for

moderation. (24) (The Joint Matriculation Board (J.M.B.), is a statutory body constituted under the provisions of section 15 of the Universities Act, No. 61 of 1955. One of the functions of the J.M.B. is to ensure that equivalent standards are maintained in schools throughout the Republic of South Africa by a system of moderation of examination papers and scripts.) (25)

After moderation the papers are printed and distributed to schools in sealed envelopes to be opened only by the Chief Invigilator on the day of the examination in the presence of the candidates.

After the papers have been written by the candidates, the scripts are submitted to the Department. A central marking committee, appointed by the Director, marks the papers with the aid of detailed marking memoranda. The marked scripts are moderated by the examiners. The marks are then submitted to the computer bureau where the results are processed. (26)

Mention has been made of both the essay type and objective type questions which are extensively used in both the internal and external examinations of the Department of Indian Affairs. Apart from these written tests, use is also made of oral and practical tests. It is therefore necessary to discuss the format of tests used in Indian schools.

1.4 FORMAT OF TESTS USED IN INDIAN SCHOOLS

Use is made of Written, Oral and Practical tests.

1.4.1 Written tests

Written tests comprise both essay and objective type questions.

1.4.1.1 Essay type tests

These tests require the pupil to do a fair measure of writing on a particular question. The setting of such tests takes little time but marking them is tedious. According to Ebel (1965) the essay tests the students ability to write, whereas the objective test tests the students ability to read, comprehend and recall. Ebel feels that essay-type tests cannot be assessed objectively, further they lack validity and reliability which are fundamental to the process of assessment. He therefore concludes that the essay type test can only reasonably test a student's ability to write. (27) Behr (1971) holds a view different from that of Ebel. For him the examinee, in an essay examination, "has to originate his own answers, express them in his own way, exercise judgment in determining the details of content to be covered and yet provide evidence of the full extent of his knowledge and understanding". (28)

The writer takes the view that the essay type-test, when used together with the objective type-test, has sufficient merit to warrant a place in educational measurement. The validity and reliability of the essay as a measuring instrument has been of considerable concern to many researchers such as Davis (1966); (29) Story (1968); (30) Ebel (1962). However, being aware of these limitations and proceeding cautiously in the assessment of essays, can lead one to use the essay as a reasonable measuring instrument. The two major limitations of the essay type test are: limited sampling of the content of the course and subjectivity in marking.

Since only a few essays can be written in the time allocated for the writing of the paper, only a limited area of the

syllabus content can be covered. Green, et al (1964) have pointed out that limited sampling may result in a pupil selecting certain sections of the curriculum only. His performance in these sections may be good, but does not give an indication of what his overall attainment in the course as a whole would be. (32)

A second characteristic of the essay type test is subjectivity of scoring. Starch and Elliott (1912) who had one hundred and forty two (142) teachers score identical copies of an English test paper found that the scores based on 100% as full marks ranged from 50% to 98% on a single script. (33) In another investigation Starch and Elliott (1912) found that 115 teachers rated a geometry paper from 28% to 92% on a single script. (34) Ruch (1929) had 91 teachers of geography score the essay test papers judged to be best, average and poorest. The scale of marks was from 0 to 20. The range of scores on the best paper was from 3 to 20, and the poorest paper from 0 to 20 and the average paper 2 to 20. (35)

Eells (1930) had 61 teachers score an examination consisting of four essay questions in geography and history, and eleven weeks later had them score the same answers again. Reliability coefficients obtained by correlating the first and second set of scores assigned by the same teachers ranged from 0,25 to 0,51 for the four essay questions. This evidence showing wide differences in the two sets of scores assigned by the same person, led him to conclude that the same individuals vary from time to time in their judgements about as widely as different individuals vary. (36)

Stalnaker (1951) on the basis of an extensive experiment in the evaluation of English essay papers concluded that, "the typical essay test as typically handled . . . is not reliably graded and, therefore, cannot stand alone as a good measuring instrument." (37)

The International Institute Examination Enquiry (1963) carried out extensive research to examine the discrepancies of different examiners in marking scripts. In the case of history, 15 scripts were selected and marked by a panel of examiners. After an interval of twelve to nineteen months these scripts were again marked by this panel, the members of which has no record of what marks they had previously allocated. The results of 3 examiners are given in the table below. (38)

TABLE 1.1

MARKS AWARDED BY EXAMINERS IN THE FIRST AND SECOND MARKING OF THE ESSAY TYPE ANSWER (39)

Candi- date	Examiner B			Examiner J			Examiner L		
	1st mark	2nd mark	Differ- ence	1st mark	2nd mark	Differ- ence	1st mark	2nd mark	Differ- ence
1	33	31	-2	31	61	+30	42	45	+3
2	27	28	+1	31	35	+ 4	32	31	-1
3	31	33	+2	43	45	+ 2	38	41	+3
4	40	47	+7	52	39	-13	38	35	-3
5	34	28	-6	47	45	- 2	40	40	0
6	37	50	+13	41	50	+ 9	36	45	+9
7	48	45	-3	58	53	- 5	47	44	-3
8	22	36	+14	36	31	- 5	33	32	-1
9	27	32	+5	43	35	- 8	28	26	-2
10	41	43	+2	57	37	-20	40	41	+1
11	29	31	+2	55	39	-16	34	32	-2
12	40	42	+2	70	62	- 8	32	29	-3
13	25	31	+6	38	33	- 5	35	31	-4
14	41	42	+1	47	48	+ 1	42	36	-6
15	44	51	+7	53	50	- 3	53	45	-8

Examiner J increased marks of candidate 1 from 31 to 61 on his second marking, thus improving this candidate's position from 15th to 2nd position. As the agreed pass mark was 40% this candidate was now given a pass mark. On the other hand, the difference in marks awarded on the two occasions by examiners B and L did not vary very much. However, an overall scrutiny of the table shows a high degree of inconsistency.

Valentine (1938) conducted an experiment to test the uniformity in marking English essays. Seventeen essays were selected which had been written by pupils who were between 11 and 12 years of age. A maximum of ten marks was to be awarded for ideas and ten for expression; spelling was to be ignored. Each essay was marked separately by thirteen examiners. No marks or corrections were to be indicated on the scripts. On the basis of this experiment, Valentine concluded that there is a high degree of inconsistency in the assessment of essays by different examiners. (40)

Subjectivity in scoring the essay, shown by practically all studies that have been mentioned, is more the result of varying standards of expectancy among the teachers concerned than of any other cause. Such standards of expectancy vary from day to day, teacher to teacher, class to class and school to school. The establishment of uniform standards of achievement in the teacher is probably a human impossibility. The teacher's assessment is the greatest variable which contributes to the subjectivity of the essay test.

Stalnaker (1951) states that the ability to obtain an accurate evaluation of essay questions is "practically prohibitive". A summary of his views on the problems of the essay examination is quoted below.

"The accurate evaluation of a well-developed essay question is a long and difficult job and one which, properly done, requires intelligence, diligence, and consistency. The expense in time and money can be justified only to the extent that essay items are developed to measure reliably important objectives which cannot otherwise be measured." (41)

Apart from the many disadvantages of the Essay type test referred to in the quotation, there are however, some advantages which are worthy of consideration.

Behr (1971) states that it is through the essay-type test that a pupil is able to develop an answer in his own way. The essay type answer reflects the creative ability of a pupil. In the case of language papers a pupil's aesthetic qualities and originality of style are brought to the fore. (42)

It is possible to adapt the essay test for practically all subjects of the school curriculum. Some types of qualities, such as mathematical skills, handwriting skills, reading ability and others, cannot be tested directly by this device, but the factual backgrounds for them frequently can be so tested.

Advocates of the essay test insist that the discussion type questions have value not found in by the objective type test in that they call for comparison, for interpretation of facts, for criticism, for defence of facts, for defence of opinion and for other types of higher mental activity.

The freedom of response that the essay test question allows is considered to be one of its main characteristics. By the nature of the question the pupil is required to survey his own background of related information and to select the related facts and organise them for expression in his own words. It is

important, however, that the freedom of selection, organisation and expression be suited to the measurable outcome of the course, and it is unfortunate that the essay type question fall short in this respect.

Nevertheless to develop optimum efficiency in the assessment of essays, Behr (1971) suggests two methods of marking i.e. impression marking and analytical marking. (43)

Impression marking is when the examiner reads through the essay and arrives at an overall impression based on a set procedure. Firstly instead of awarding the final mark, the examiner should rank order the scripts guided by a system of grading, such as the following:

- (a) Excellent, or falling in the broad category
80% to 100%.
- (b) Good, or falling in the broad category
60% to 79%.
- (c) Mediocre, or falling in the broad category
40% to 59%.
- (d) Weak, or falling in the broad category
0% to 39%.

Secondly, the examiner should have a clear outline in his mind of the essential desirable and undesirable features he is looking for. Thirdly, the scripts should be re-marked independently by a second, and where possible, a third examiner and their judgements averaged.

In the Senior Certificate Examination of the Department of Indian Affairs, essay questions in Afrikaans and English are marked twice by two different examiners. If there is a wide variation in the scores of the two examiners, then they are marked by a third examiner who decides on the final score. (44)

In analytical marking the examiner prepares a detailed marking scheme and awards marks for specific aspects of the answer. This is particularly necessary where the answers are largely of a factual nature. Some educationalists hold the view that an essay or composition in a language can be assessed more objectively if marked analytically. (45)

Research has, however, shown that the difference in marks awarded by examiners whether by impression or analytical marking is negligible. What does differ, however, is the standard of marking of different examiners. (46)

It now becomes necessary to consider the second type of written tests used in Indian schools viz: the objective type test.

1.4.1.2 The objective type test

According to Ebel (1974), Behr (1971) and Coulter (1974) an objective type test is one in which the questions, or items as they are usually called are so constructed that there is only one pre-determined correct answer for each item. (47)(48)(49)
The subjective element in marking or scoring is completely eliminated. The test can be marked by a computer or an individual without any knowledge of the subject provided he is supplied with an answer key.

In the objective type test the candidate has to provide answers to a very large number of separate items in a comparatively short period of time by making a series of marks on the answer sheet or question booklet. He has, as H.G. Macintosh and R.B. Morrison put it, "to read and think rather than to think and write". (50)

Objective testing is to-day widespread in education, industry, business and research. While much of its popularity is due to the ease with which such tests are scored, it has other real advantages. The very ease with which tests can be used places a special obligation on the test user to see that the tests are the best available, are fair and are being used appropriately. (51) Objective test items are extensively used in Indian schools for evaluation of pupil attainment.

Objective tests according to Coulter (1974) are used for many purposes among them selection, placement, evaluation of training, as a motivational device, for the evaluation of promotability, as a teaching device and for the detection of special weaknesses. (52)

1.4.1.2.1 Nature of objective type test

Almost all objective type tests take the form of multi-choice questions with four or five alternatives, though sometimes the matching of items is also used. Behr (1971) states the familiar true-false or alternative response items have many defects and are seldom used. Then there is the simple completion item in which the examinee has to supply, instead of select, the answer. (53) Connaughton (1969) states that examinations involving multi-facet items have been introduced. These multi-facet items are an adaptation of the true-false type item. (54) The more important types of objective-type items will now be discussed.

Multi-choice items

Ebel (1965) states that in a multi-choice item the correct answer to question is presented along with several alternatives, called "distractors", all of which are incorrect. The distractors are carefully compiled on the basis of the errors in thinking which pupils are likely to make. The shade of difference between the answer and distractors in a

multi-choice item must be so subtle and slight that the child must be able to arrive at the correct answer only after careful thought. (55)

The multi-choice type of question can be adapted to a wide variety of approaches involving the use of graphs, maps, diagrams and written passages. The number of options given in each question may be four or five. Behr (1971) states that, since the value of the question depends upon the distractors, a four option item may prove just as effective as a five-option item. One has to guard against items which are so constructed that the answer is obvious. (56)

Matching items

In this type of question the pupil is given two lists and asked to pair off correctly the items in the one list with the items in the other. Usually more items are placed in one list than in the other. This is to increase the difficulty of association. On the other hand, if the two columns are equally paired, one incorrect association will produce two errors. (57)(58)

Completion items

Here the pupil has to produce the answer himself by writing a word, phrase, sentence or numeral.

Multi-facet items

Multi-facet items are useful for examining mathematics although they can be used for examining other subjects as well. In the multi-choice question one independent decision is called for. It is, however, frequently possible to consider a given mathematical statement or situation from different viewpoints i.e. facets, and hence requires from it a variety of decisions. Thus in devising the multi-facet question the alternative statements provided are not framed as possible answers to a specific question, but as a

variety of possible deductions to be drawn from a given situation. The alternative statements are deliberately phrased so that some are true and others false. The examinee has to decide as to the truth or falseness of each statement made about each situation. Behr (1971) states that the multi-facet questions can test "fairly and squarely" the candidates absolute grasp of many detailed mathematical ideas spread widely over the mathematical knowledge that he has amassed. ⁽⁵⁹⁾ Connaughton (1969) has found that the multi-facet tests have high internal consistency, reliability and validity. In marking the multi-facet test, the right minus wrong system is generally employed, i.e. each correct response is credited with +1 and each incorrect response with -1. This method of scoring eliminates random guessing. ⁽⁶⁰⁾

Tests in Indian schools generally have one or more types of objective type items included. These items are included in tests ranging from standards 3 to 10. The complexity of the items increases in the higher standards. The advantages and disadvantages of the objective type questions will now be considered.

1.4.1.2.2 Advantages of the objective test

Of the several merits of the objective type examination, two major advantages are to be found in sampling and scoring.

Sampling

Although most tests measure only samples of pupil performance, the objective test, by its nature, samples so widely that the results obtained from its use closely approximate those that would be obtained if pupil performance in the subject in question could be measured completely. A test made up of a hundred or so short, well selected questions or items will adequately sample achievement for many purposes.



Scoring

In an objective test the items are so stated that the answers are brief, and usually one correct answer is possible. A highly objective test may be scored repeatedly by one person or it may be scored by a large number of different persons with practically no disagreement in the scores assigned. Thus in the objective test the responses can be assessed on an impersonal basis, entirely independent of the personal judgement of the examiner. This is true, of course, only when tests are constructed, with a specific purpose in mind and the tester must know in what way the test contributes to his purpose. (61)

Economy of time

The objective type test may take time to construct but marking is quicker. The form in which the objective item is stated makes it possible for the pupil to record his response quickly. This in turn permits many specific reactions to be called for, in a relatively brief period of working time. In this way a much wider area of the course content can be sampled in a given period, resulting in a higher reliability of measurement per unit of marking time.

If the objective tests are made in accordance with the best practices, they can be scored by simple keys and stencils in the hands of ordinary clerical help. Objective tests are readily adaptable to machine scoring. (62)

Elimination of uncalled for details

Fluency of expression and mastery of language have always been recognised as factors in examinations of the discussion type. Because of the nature of the items, the amount of writing done by pupils in responding to objective tests is reduced to a minimum. This practically eliminates padding and the advantage that rapid and fluent writers have over those not so gifted. The fact that one pupil can write more

material than another in the same length of time should not result in his receiving higher marks in his school subjects.

By normal practice every item in an objective type test is awarded one mark, irrespective of its difficulty.

The fact that there is no weighting of items of marks does not adversely affect the discriminating power of the test as a whole. Since all candidates are required to attempt all the items, and since the items are graded in difficulty, the better candidates will show their superior ability by getting more items correct and thus obtain a higher score. (63)

1.4.1.2.3 Some disadvantages of the objective type test

A number of rather important criticisms of objective tests have been brought forward. The following, while not complete, probably contains the more significant of these criticisms.

Neglect of training in expression of thought

Teachers sometimes feel that the objective test does not allow pupils the opportunity to organise and express their thoughts. The objective test tends to suppress creative thought. Creativity values essentially the capacity to invent and innovate, whereas conventional intelligence requires rather the reproduction of the already learned (Guildford, 1950). (64)

Some educators contend that the objective test while fulfilling the role of determining conventional intelligence, lacks the potential to determine creativity.

Overemphasis on factual knowledge

The objective type test emphasises a thorough knowledge of the content to be studied. Pupils with a short term memory may find difficulty in remembering the entire content. It could lead to frustration and failure if the content to be covered is vast.

Encouragement of guessing

Some teachers and critics believe that the objective type test encourages guessing to an undue extent. While this may be so the effects of guesswork are negligible in tests of about 100 test items. The probability of a pupil getting a true or false question wrong or right is 50%. When two questions are included, the probability drops to 25%. Therefore, one may conclude that in a test of 100 test items guessing will have an insignificant effect. (66)(67)

1.4.2 Oral tests

The introduction of Differentiated Education has resulted in oral tests being introduced in English and Afrikaans in Indian schools. (68) Pupils are assessed during the year in oral work in the languages. The marks obtained by pupils in the oral tests are used at the end of the school year for promotion purposes.

Candidates who take History as one of the subjects for the Senior Certificate Examination of the Department are required to defend their "mini-thesis" by oral-tests conducted by Departmental moderators (The mini-thesis is an assignment presented by candidates taking History as one of the subjects for the Senior Certificate Examination of the Department. The assignment is presented as part fulfilment for the History course. It constitutes 20% of the total marks allocated to History; and is commenced in the second half of a pupil's standard 9 year and completed in the first half of the standard 10 year). (69)

In 1978 a Departmental investigation was undertaken to determine the relationship between the marks obtained by candidates in the oral and written tests in English and Afrikaans for the Senior Certificate Examination of 1977. The correlation coefficient in respect of the marks obtained in the oral and written tests

by the same candidates was computed. The correlation coefficients and significance levels are reflected in table 1.2.⁽⁷⁰⁾

TABLE 1.2

CORRELATION COEFFICIENTS AND SIGNIFICANCE LEVELS FOR MARKS
OBTAINED BY CANDIDATES IN THE ORAL AND WRITTEN ASPECTS OF
AFRIKAANS AND ENGLISH IN THE SENIOR CERTIFICATE EXAMINATION
OF 1977 ⁽⁷¹⁾

Subject/Grade	N	r	Significance levels
Afrikaans Higher	100	0,45	1%
Afrikaans Standard	100	0,77	1%
English Higher	100	0,62	1%
English Standard	100	0,18	Not significant

N = sample size

r = correlation coefficient

It was only in English Standard Grade that an indifferent, almost negligible, relationship between the oral and written marks was found. To improve the reliability and validity of its examination in English Standard Grade, the Department has indicated to its English Subject Committee that a more structured approach must be adopted for oral assessment.⁽⁷²⁾

Oral tests may be used with individual pupils satisfactorily if proper advance preparations are made, if consistent procedures are followed in the question session, and if scoring and rating methods are systematically applied.

1.4.3 Practical tests

Here again the system of Differentiated Education necessitated the introduction of practical tests in subjects such as Biology, Physical Science, Geography, Housecraft, Woodwork, Metalwork and

Home Economics. ⁽⁷³⁾ Pupils are required to perform a given task or set up an experiment within a specified time. The examiner makes an assessment. In subjects like Woodwork, Metalwork and Home Economics, the practical assessment is based on an examination of the completed article or project.

To determine the validity and reliability of the practical marks of candidates who entered for the Senior Certificate Examination of December 1977, an investigation was undertaken in 1978. The correlation coefficient in respect of the practical and written marks of the same candidates were computed. The correlation coefficients and significance levels are indicated in table 1.3.⁽⁷⁴⁾

TABLE 1.3

CORRELATION COEFFICIENTS AND SIGNIFICANCE LEVELS IN THE PRACTICAL AND WRITTEN ASPECTS OF A SELECTED NUMBER OF SUBJECTS IN THE SENIOR CERTIFICATE EXAMINATION OF 1977 ⁽⁷⁵⁾

Subject	N	r	Significance levels
Physical Science Higher	100	0,69	1%
Physical Science Standard	80	0,17	Not significant
Biology Higher	100	0,68	1%
Biology Standard	100	0,70	1%
Geography Higher	100	0,36	1%
Geography Standard	100	0,24	5%
Housecraft Standard	100	0,16	Not significant
Home Economics Higher	100	0,59	1%
Home Economics Standard	100	0,60	1%
Woodwork Standard	80	0,28	5%
Metalwork Standard	80	0,19	Not significant

This investigation has lead the Department to request from examiners possible reasons for the low correlation in certain of the subjects.

It may be stated that the oral, practical and written tests are important tools in the assessment and measurement of pupils. An omission of the practical, oral or written aspect of assessment will not give educators a total picture of the pupil. Nevertheless, the validity and reliability of these tests need to be considered and questioned at all times. A teacher who is cautious can but use these instruments only to the advantage of pupils.

Apart from these school based tests that constitute an examination, the Department of Indian Affairs also makes use of standardized tests compiled by the Human Science Research Council (HSRC).⁽⁷⁶⁾ (The HSRC undertakes, promotes, and coordinates research in the human sciences, advises the Government and other bodies on the utilization of research findings and disseminates information on the human sciences).⁽⁷⁷⁾

1.5 THE STANDARDISED TESTS USED IN INDIAN SCHOOLS

The following standardized tests devised by the HSRC are used in schools.

Group Test for Indian South Africans (GTISA).

This test was devised in 1968 and is designed to measure the general mental ability of pupils. Each of these tests consists of 3 verbal and 3 non-verbal subtests. Two alternative forms are available for the Junior and Intermediate Series, but only one for the Senior Series. The test makes provision for 3 scores, namely verbal, non-verbal and total score.

Each subtest has a time limit and the whole test takes about two hours to complete. For the Junior Series norms have been calculated for each term, as well as for the age groups 10, 11, 12 and 13 years. For the Intermediate Series norms have been calculated for each semester as well as for the age groups 13, 14, 15 and 16 years. For the Senior Series norms have been calculated for each semester as well as for the age groups 16, 17, 18 and 19 years. (78) The GTISA is the most commonly used test in Indian Schools. Only in cases where the scholastic performance of pupils is not commensurate with the scores in the GTISA, is the Individual Scale for Indian Pupils (ISISA) applied. This test was devised in 1971 and it measures intelligence. The test can only be applied individually. There are ten subtests of which five are verbal and five non-verbal. The test is intended for the age range 8 to 17 years, and the full scale takes about 80 minutes to apply. The raw scores for each separate subtest are converted to standard scores, which are added to obtain a verbal IQ, a non verbal IQ and a total IQ. (79)

There are other tests also devised by the HSRC which are used to a lesser extent in Indian schools. These tests are the following:

Aptitude Tests for School Beginners (ASB)(1974)

Junior Aptitude Tests for Indian Pupils (1972)

Tests in Arithmetic and Language for Indian Pupils (1968)

Interest Questionnaire for Indian Pupils (1969)

Intermediate Personality Questionnaire for Indian Pupils (IPQI)(1974). (80)

The tests in Indian schools are administered by the Psychological Section of the Division of Education. It must, however, be pointed out that the test scores both in the GTISA and the ISISA have been put to little use in Indian schools. The appointment of Guidance-Counsellors, a recent feature in Indian schools, could lead to greater use being made of standardised tests in the education of the child.

In the main, standardised tests are used for purposes of identifying the mentally handicapped, gifted, average, above average and below

average pupils. It is used by guidance counsellors for purposes of psychological and vocational counselling. To some extent it is used in detecting weaknesses in specific subjects such as those involving mathematical and language concepts or skills. (81)

It must, however, be pointed out that until now, standardised test scores are not used in determining whether a pupil should be promoted or not. The standardised test scores of pupils are not considered even when a decision has to be made as to the type of secondary school course a pupil has to follow at the end of standard 5. These decisions are made solely on the pupils performance in the examination.

It is, however, hoped that increasing use would be made of standardised test scores in not only selecting pupils for the different types of secondary school courses, but also when promotion of pupils from one class to the next is considered. The standardised test scores must be considered together with scholastic attainment tests and other sources of information about a pupil, when a decision has to be made as to whether a pupil should be promoted into the next class or not.

At this stage it is considered necessary to discuss briefly the attributes of a good test. The attributes of a good test are its reliability, validity and discriminating power. These have already been referred to but need elaboration.

1.6 THE ATTRIBUTES OF A GOOD TEST

If a test is to be used as a measuring instrument it is important to know just how well it measures. This means that the test must be assessed, preferably under the same circumstances and with the same kind of testees as those for whom the test is intended. Until a test has been assessed it cannot justifiably be claimed that it is objective. Assessing a test provides information about the measurement qualities of the test and also information that will enable the

teacher to construct better tests in future. (82)(83) Some important qualities of a test as a measuring instrument will now be outlined.

1.6.1 Reliability

Behr (1971), Coulter (1974), and Ebel (1974) state that the reliability of a test is a measure of its consistency. (84)(85)(86) This can refer to the consistency of equivalent tests which should produce equivalent scores. This can be evaluated for a single test by examining the internal consistency of the test, that is the equivalence of items that are contained in it. The consistency can also refer to the consistency across time. A test should produce a similar score for a person each time it is administered. This is measured by the correlation between scores obtained on testing and then re-testing. A correlation coefficient of above 0,7 is considered satisfactory. How much emphasis is placed on each kind of consistency will depend on what the test is being used for.

1.6.2 Discriminating power

The discriminating power of a test is its ability to distinguish between testees who are nearly the same. (87)(88) In theory a test item usually has a point of maximum discrimination that is related to its difficulty level. This power to discriminate among candidates can be achieved only if the questions or items vary in difficulty. It is therefore necessary to carry out an analysis of the questions to determine whether they are fair to the candidates. This involves determining, the index of difficulty and the discrimination index of each item. Such an item analysis is usually confined to objective type tests.

Index of difficulty

The index of difficulty (F) of an item is defined as the percentage of all candidates who get the item right. Thus, if 150

candidates write the examination and 80 make a correct response to a particular item, the index of difficulty of that item is 53%. (89)

$$F = \frac{\text{number of right responses}}{\text{number of candidates}} \times 100$$

The proportion of candidates who get the item right is related to the difficulty of the item, because the larger the proportion getting an item right, the easier it is. The greater the difficulty index, the easier the item.

Discrimination index

The discrimination index of a test item provides an indication of how that item correlates with the test as a whole.

The procedure for determining the discrimination index (D) of a test item is as follows:

The candidates are arranged in rank order from the highest to the lowest on the basis of the total score obtained by each in the test as a whole. Two groups of equal size are selected, one from the top and the other from the bottom end of the scale. These constitute the high and the low scorers. Usually each group consists of 27% of the total test population, though any figure between 25% and 33 $\frac{1}{3}$ % will do. The number of candidates in each group who get the item correct is noted. Now a calculation is made, using the formula

$$\frac{N_h - N_l}{n}$$

where N_h is the number of correct responses in the group of high scorers,

N_l is the number of correct responses in the group of low scorers and

n the number of candidates in one of the groups.

The results that we get will range from -1,0 to +1,0. An item which discriminates perfectly will get a score of +1,0. An item which does not discriminate at all (i.e. the same number in both groups get it right) will give a score of 0. An item with a negative result is unsuitable, and should not be used again. (90)(91)

1.6.3 Validity

Reliability and discriminating power tell how good a test is as a measuring instrument, but it is also necessary to know that the test is measuring what it is supposed to be measuring. (92)(93) This is the validity of the test. Validity can be related to the content of the test, the trait it is supposed to measure or the area of knowledge it is supposed to assess. Coulter (1974) states that validity may measure the ability of the test to predict a criterion. If this is the case then a test will have as many validities as there are criteria that it is supposed to predict. (94)

A good test must be reliable, valid and be able to discriminate the pupils. Apart from these qualities, the appropriateness of the test must also be considered. Appropriateness involves many aspects ranging from the cost-effectiveness of the testing programme to ethical considerations. One must consider why one wants to test and how to assess whether the test is achieving its purpose.

Having considered assessment and measurement in education, the promotion of pupils from one class to the next under the system of differentiated education in Indian schools will be considered in the following chapter.

R E F E R E N C E

1. EBEL, R.L. : "The Concept of Evaluation", Paper presented at the National Conference on Evaluation, Johannesburg, July 1974 p.1
2. HUBERMAN, M. : "Evaluating the Effectiveness of Schooling International Review of Education, Vol. 19, 1973 pp. 357-371
3. SCHOFIELD, H. : "The Educative use of Evaluation in the Primary School", Paper presented at the National Conference on Evaluation Johannesburg, July 1974 p.1
4. MONTGOMERY, R.J. : Examinations, Longmans, Great Britain, 1965. pp. 245-264
5. DAVIS, F.B. : Educational Measurement and their Interpretation, Wadsworth, 3rd Edition, California, 1966 p.14
6. RICHMOND, W.K. : "Its a Question of Evaluation", Scottish Education Journal, Vol. 58, No. 14, April 1975 p.407
7. VAN DER WALT, J.S. : "The use of Standardised Tests", Free State Education News, No. 12, 1974 pp.36-43
8. NIVEN, J. : "Assessment of what and for what in the Primary School", The Transvaal Education News, Vol.74, No.8, August 1977 pp.11-14
9. BEHR, A.L. : A Textbook of Educational Method, van Schaik, Pretoria, 1971 p.111
10. CRAIG, J.K. : "Internal Assessment in Secondary Schools with special reference to certain overseas country", Paper presented at the National Conference on Evaluation, Johannesburg, July 1974 pp.1-5
11. JOOSTE, J.H. : "Assessment in Differentiated Education", Paper presented at the National Conference on Evaluation, Johannesburg, July 1974 p.1

12. LORET, P.G. : "Implementing, Evaluating and using a statewide assessment program", Paper presented at the annual meeting of the National council on measurement in Education, Washington D.C., March 1975 p.13
13. KERLINGER, F.N. : Foundations of Behavioural Research, Holt, Rinchart and Winston, London, 1972 p.480
14. COULTER, M.N. : "Objective Tests - Problems and Practice", Paper presented at the National Conference on Evaluation, Johannesburg, July 1974 p.1
15. BEHR, A.L. : Methods and Techniques in Educational and Psychological Research, van Schaik, Pretoria 1973 p.33
16. DEPARTMENT OF INDIAN AFFAIRS - (DIVISION OF EDUCATION) : Handbook for Principals, 1978 pp.G1-G6
17. DEPARTMENT OF INDIAN AFFAIRS - (DIVISION OF EDUCATION) : Circular I.E. No. AB of 1978 File No. 19/20/6/1
18. IBID
19. DEPARTMENT OF INDIAN AFFAIRS - (DIVISION OF EDUCATION) : Circular I.E. No. 4 of 1977 File No. 9/34/1/16
20. DEPARTMENT OF INDIAN AFFAIRS - (DIVISION OF EDUCATION) : File No. 19/20/6/2
21. DEPARTMENT OF INDIAN AFFAIRS - (DIVISION OF EDUCATION) : Circular I.E. No. 4 of 1977 File No. 9/34/1/16
22. IBID
23. DEPARTMENT OF INDIAN AFFAIRS - (DIVISION OF EDUCATION) : File No. 1/9/23
24. IBID
25. BEHR, A.L. : New Perspectives in South African Education, Butterworths, Durban, 1978 p.53
26. DEPARTMENT OF INDIAN AFFAIRS - (DIVISION OF EDUCATION) : File No. 19/20/6/2
27. EBEL, R.L. : Measuring Educational Achievement, Prentice Hall, New Jersey, 1965 p.36

28. BEHR, A.L. : A Test Book of Educational Methods, van Schaik, Pretoria, 1971 pp.115-116
29. DAVIS, F.B. : Educational Measurement and their Interpretation, Wadsworth, California, 1966 p.72
30. STORY, A.G. : "Some Evidence in the Essay Item Case" The Journal of Educational Research, Vol. 61, No. 8, April 1968 pp.351-354
31. EBEL, R.L. : "Measurement and the Teacher" The Education Digest, Vol. 28, December 1962 pp.38.41
32. GREEN, A.H.,
JORGENSEN, A.N. AND
GERBERICH, J.R. : Measurement and Evaluation in Secondary School, David McKay, New York, 1964 pp.142-3
33. STARCH, D. AND ELLIOTT, E.C. : "Reliability of Grading High School Work in English", School Review, Vol. 20, September 1912 pp.442-57
34. IBID
35. RUCH, A.M. : The Objective or New Type Examination, Scott, Foresman and Co., Chicargo, 1929 pp.78-81
36. EELLS, W.C. : "Reliability of Repeated Grading of Essay Type Questions", Journal of Educational Psychology, Vol 21, January 1930 pp.48-52
37. STALNAKER, J.M. : "The Essay Type of Examination" Educational Measurement, American Council on Education, Washington D.C. 1951 p.499
38. VALENTINE, C.W. : The mark of Examiners - Reliability of Examination, Methuen, 1938 pp.10-20
39. IBID
40. IBID
41. STALNAKER, J.M. : op. cit., p.502
42. BEHR, A.L. : A Text Book of Educational Methods, van Schaik, Pretoria, 1971 pp.115-116

43. IBID : pp. 116-117
44. DEPARTMENT OF INDIAN AFFAIRS - : File No. 19/20/6/2
(DIVISION OF EDUCATION)
45. BEHR, A.L. : op. cit., pp.116-117
46. SCHONELL, F.J. AND SCHONELL, F.E.: Diagnostic and Attainment Testing,
Oliver and Boyd, Edinburgh 1965
pp.187-97
47. EBEL, R.L. : "Knowledge Versus Ability in Achieve=
ment Testing", Paper presented at the
National Conference on Evaluation,
Johannesburg, July 1974 pp.1-6
48. BEHR, A.L. : op. cit., p.121
49. COULTER, M.N. : "Objective Tests - Problems and
Practice", Paper presented at the
National Conference on Evaluation,
Johannesburg, July 1974 p.1
50. MACINTOSH, H.G. AND : Objective Testing, University of London
MORRISON, R.B. Press, London, 1969 p.17
51. COULTER, M.A. : op. cit., p.1
52. IBID
53. BEHR, A.L. : op. cit., pp. 122-128
54. CONNAUGHTON, I.M. : "The validity of examinations at 16
plus", Educational Research, Vol. 11,
No. 3, 1969 p.168
55. EBEL, R.L. : Measuring Educational Achievement,
Prentice Hall, New Jersey, 1965
pp.36-38
56. BEHR, A.L. : op. cit., p.126
57. EBEL, R.L. : op. cit., p.36
58. BEHR, A.L. : op. cit., p.125
59. IBID : p. 126
60. CONNAUGHTON, I.M. : op. cit., p.168
61. GREEN, H.A. ET AL : op. cit., p.165
62. BEHR, A.L. : op.cit., p.121

63. GREEN, H.A. ET AL : op. cit., p.165
64. GUILFORD, J.P. : "Creativity", American Psychologists,
Vol. 5, 1950 pp.444-454
65. IBID
66. EBEL, R.L. : "Measurement and the Teacher",
The Education Digest, Vol. 28,
December 1962 pp.38-41
67. GREEN, H.A. ET AL : op. cit., p.163
68. DEPARTMENT OF INDIAN AFFAIRS - : Handbook for Principals, 1978
(DIVISION OF EDUCATION) Annexure 3 pp.1-5
69. DEPARTMENT OF INDIAN AFFAIRS - : Circular I.E. No. N of 1975
(DIVISION OF EDUCATION) File No. 19/15/7/4/11
70. DEPARTMENT OF INDIAN AFFAIRS - : File No. 19/20/6/2
(DIVISION OF EDUCATION)
71. IBID
72. IBID
73. DEPARTMENT OF INDIAN AFFAIRS - : Handbook for Principals, 1978
(DIVISION OF EDUCATION) Annexure 3, pp.1-5
74. DEPARTMENT OF INDIAN AFFAIRS - : File No. 19/20/6/2
(DIVISION OF EDUCATION)
75. IBID
76. DEPARTMENT OF INDIAN AFFAIRS - : File No. 19/34/3
(DIVISION OF EDUCATION)
77. BEHR, A.L. : New Perspectives in South African
Education, Butterworth, Durban, 1978
p.71
78. HUMAN SCIENCE RESEARCH COUNCIL : Catalogue of Tests (1976),
Pretoria, 1976 p.48
79. IBID : p. 49
80. IBID : pp. 50-52
81. DEPARTMENT OF INDIAN AFFAIRS - : File No. 19/34/3
(DIVISION OF EDUCATION)
82. COULTER, M.A. : "Objective Tests - Problems and
Practice", Paper presented at the
National Conference on Evaluation,
Johannesburg, July 1974 pp.3-5

83. BEHR, A.L. : A Textbook of Educational Method,
van Schaik, Pretoria, 1971 p.128
84. IBID
85. COULTER, M.N. : op. cit., p.3
86. EBEL, R.L. : "The Concept of Evaluation", Paper
presented at the National Conference
on Evaluation, Johannesburg, 1974
pp.1-6
87. COULTER, M.N. : op. cit., p.3
88. BEHR, A.L. : op. cit., p.130
89. IBID : pp. 130-131
90. GREEN, H.A. AND : The use and interpretation of High
JORGENSEN, A.N. School Tests, Longmans, New York,
1936 p.138
91. EGGLESTON, J.F. AND : Studies in assessment, English
KERR, J.F. Universities Press, Great Britain,
1969 pp.30-33
92. GREEN, H.A. AND : op. cit., p.105
JORGENSEN, A.N.
93. BEHR, A.L. : op. cit., pp.128-129
94. COULTER, M.N. : op. cit., p.3

CHAPTER 2

2. THE PROMOTION, PROCEDURES BASED ON ASSESSMENT IN THE INDIAN EDUCATIONAL SYSTEM FOLLOWING THE INTRODUCTION OF DIFFERENTIATED EDUCATION

2.1 DIFFERENTIATION IN GENERAL IN SOUTH AFRICA CULMINATING IN I.E. CIRCULAR NO. 28 OF 1972

Education provided in accordance with the ability, aptitude and the interest shown by the pupil may be termed differentiated education. Another term synonymous with differentiation is streaming which has been applied with a measure of success in comprehensive schools in England. (1)(2)

Van der Walt (1972) stated that differentiation can be regarded as synonymous with individualization. It is simply the adjustment of education to individual differences. (3)

In South Africa, the first National Advisory Education Council instituted in 1962 provided the impetus for the appointment in 1964 of a committee under the chairmanship of the Director of the National Bureau of Educational and Social Research (now the President of the Human Sciences Research Council) and comprising senior officials from each education department to look at the problems of differentiated education from a national viewpoint. (4)(5) This Committee was required "(a) to study the question of differentiated education and guidance; (b) to determine what was already being done in these fields; and (c) to pinpoint the problems and to determine what research should still be undertaken before any steps were taken to evolve a mutually acceptable plan." (6)

In drawing up its report, the Committee was influenced by the reports of various commissions presented between 1939 and 1955. (Nicol Commission (1939), Wilks Committee Report (1946), De Villiers Commission Report (1948), Pretorius Commission (1951), Steyn Committee (1953), Van Wyk Report (1955)). (7)(8)(9)

The Committee brought out a comprehensive report in two parts in 1971. By then the National Education Policy Act (No. 39 of 1967) had already been promulgated and the main recommendations both in regard to the division of the educational system into four phases, and the provision for guidance were accepted by the Government and implemented by regulations published in the Government Gazette of 12 November, 1971. (10)

As early as January 1966, in terms of Circular No. 102 of 1965, the Transvaal Education Department permitted a pupil to change his curriculum at any stage of his entire secondary course. In this respect it may be pointed out that this Department adopted the three stream policy. The A stream candidates were prepared for the Senior Certificate with Matriculation Exemption. On obtaining the Senior Certificate with Matriculation Exemption these candidates could study for degrees at Universities. The B stream candidates were prepared for the Senior Certificate which would enable them to study for a diploma at tertiary level, while the C stream candidates were prepared for apprenticeship or employment. Their education terminated at the end of standard 8. (11)

Following on Act No. 39 of 1967 and regulations published in the Government Gazette of 12 November, 1971, the Natal Education Department implemented differentiated education at the beginning of 1973. The Department of Indian Affairs, Division of Education, followed suit in 1973 because the pupils of this Department were then writing the Senior Certificate Examination controlled by the Natal Education Department. By Circular No. 28 of 1972 dated 4 August 1972, the Division of Indian Education notified schools under its control about the implementation of the new system of differentiated education and the four phase system. (12) The Orange Free State Education Department, the Cape Province Education Department and the Department of Coloured Affairs introduced differentiated education as from the beginning of 1974. (13)(14)(15)

To understand the system of differentiated education a brief overview of the four phase system is necessary.

2.2 AN OUTLINE OF THE PROVISIONS OF THE FOUR-PHASE SYSTEM OF SCHOOLING IN INDIAN EDUCATION

The four-phase system of differentiated education as laid down in the National Education Policy Act (No. 39 of 1967) for Whites was introduced in Indian schools in 1973. In Indian Education the four-phase system is identical to that for Whites. (16)

The twelve years of schooling are divided into (i) the Junior primary phase, covering the first three years of schooling and embracing Class 1, Class 2 and Standard 1; (ii) the senior primary phase, covering the second three years of schooling and embracing Standards 2, 3 and 4; (iii) the junior secondary phase covering the third three years of schooling, and embracing Standards 5, 6 and 7; (iv) the senior secondary phase involving the last three years of schooling and embracing Standards 8, 9 and 10. At the end of this phase the pupils write the Senior Certificate Examination, which may be taken with or without matriculation exemption. Subjects may be offered at Higher or Standard Grade. (17)(18)

Table 2.1 is a flow chart reflecting the four-phase system of differentiated education in operation in Indian schools. The flow chart has been adapted from Behr (1978) - New Perspective in South African Education.

The detailed analyses of the whole system of differentiated education will be discussed in the sections that follow.

FLOW CHART SHOWING THE FUNCTIONING OF THE SYSTEM OF DIFFERENTIATED EDUCATION (19)

AGE +/-	SCHOOL PHASE	CLASS	C O U R S E S	
6 7 8	PRIMARY PHASE	PHASE ONE JUNIOR Class i Class ii Std. 1	ACADEMIC COURSE Pupils follow academic course of instruction.	
		PHASE TWO SENIOR Std. 2 Std. 3 Std. 4	Pupils follow academic course of instruction.	
9 10 11	SECONDARY PHASE	PHASE THREE JUNIOR	Std. 5	Pupils follow academic course which comprises: compulsory examination subjects. non-examination subjects
			Std. 6	Pupils follow academic course which comprises: Compulsory examination subjects. Optional examination subjects. Compulsory non-examination subjects.
		Std. 7	(Pupils are advised to choose subjects which will benefit them in the field of study which they plan to follow at a later stage.)	
		Std. 8	Pupils select and follow a field of study. Such a field comprises: Official languages Subjects characteristic of the field. Compulsory non-examination subjects.	
PHASE FOUR SENIOR	Std. 9	Fields include Natural sciences Humanities Commercial General Technical Home Economics	Pupils follow one of two lines of study Technical General Courses comprise: Compulsory examination subjects i.e.: Official languages Back ground subjects Practical subjects.	
	Std. 10	These courses may lead to University Entrance.	Compulsory non-examination subjects	

38

1st Phase
1st year Std. 6
2nd year Std. 7
3rd year Std. 8
4th year Std. 9
5th year Std. 10

2nd Phase

2.2.1 The junior primary phase

In classes 1 and 2; and standard 1, differentiation is based on the manner of presentation of subject matter. "The subject matter is presented in a manner that will develop the potential of every child to the utmost". (20)

There is no differentiation in the subject matter to be presented in this phase. The basis is class teaching, but within it, provision is made for individual help to pupils through grouping. The emphasis in this phase is the development of basic skills such as reading, mathematics and writing.

2.2.2 The senior primary phase

In this phase class teaching still forms the basis of the educational programme, but subject teaching may be attempted in certain subjects, i.e. the class teacher is responsible for teaching all subjects. However, in certain subjects, for example, music, art, physical education and Afrikaans, specialist teachers are utilized for teaching these subjects. There is no differentiation in the subject matter to be presented. Grouping of pupils into ability groups is still a feature. The Departmental circular states the following as the aim of this phase "to develop to the utmost" pupil's "ability". (21) Here again the emphasis is on reading, writing and mathematics in standard 2, and in standard 3 and 4 some attention is also given to History, Geography, Health Education and General Science.

2.2.3 The junior secondary phase

The syllabuses for subjects in this phase are not differentiated, but the subject matter is presented, "in a differentiated manner to enable pupils to obtain the maximum benefit from the educational programme according to their aptitude

and ability. This means working as far as possible in ability groups". (22)

During this phase, pupils who are unable to benefit from the normal educational programme, are identified. A more practical and vocationally orientated course is provided for such pupils.

In the first two phases there is no differentiation in the subject matter to be studied. Most subjects are compulsory and the emphasis generally is on development of basic skills e.g. reading, writing and mathematics. In phase three, the only differentiation that takes place is that pupils, who cannot cope with the ordinary school work, are separated and a more practical and vocationally orientated course is provided for such pupils. The education provided in the first three phases are of a general formative nature aimed at developing the basic skills required for phase 4 education.

2.2.4 The senior secondary phase

The educational programme during this phase provides for extensive differentiation. Pupils are offered various fields of study and in certain subjects, within the fields of study, a subject may be offered on either the Higher or Standard grade. Subjects that are offered on two levels are taught and examined at two levels. The emphasis in this phase is on subject teaching and the development of the potential of every child to the fullest.

At this stage it is necessary to examine the curricula and field of study in the different phases as well as the promotion requirements from one class/standard to the next in the system of differentiated education.

2.3 CURRICULA, FIELD OF STUDY AND PROMOTION REQUIREMENTS IN THE JUNIOR PRIMARY PHASE

2.3.1 Curricula and field of study

The Department of Indian Affairs, Division of Education prescribes the time to be spent on each subject in the junior primary phase. ⁽²³⁾ The table below reflects the subjects taught and the weekly time allocation for Classes 1, 2 and Standard 1.

TABLE 2.2

SUBJECTS AND WEEKLY ALLOCATION OF TIME FOR THE JUNIOR PRIMARY PHASE ⁽²⁴⁾

SUBJECT	CLASS I	CLASS II	STANDARD 1
	minutes	minutes	minutes
First Language	240	240	290 (13)
Second Language	-	-	180 (6)
General Mathematics	240	240	270 (9)
History	-	-	60 (2)
Geography	-	-	60 (2)
Elementary Science	-	-	60 (2)
Health Education	60	60	30 (1)
Handicrafts/Sewing/Handwork	60	60	60 (2)
Right Living	60	60	60 (2)
Physical Education	60	60	60 (2)
Music	60	60	60 (2)
Art	60	60	60 (2)
Writing	210	210	90 (3)
Guidance	30	30	30 (1)
Library	-	-	-
Study of Environment	90	90	-
Assembly	30	30	30 (1)
TOTAL	1 200	1 200	1 500

Figures in brackets shown after the time allocation indicate the number of half-hour periods per week in respect of the relevant subjects in standard 1.

Second Language (Afrikaans), History, Geography, Elementary Science and Library are not taught in classes 1 and 2.

In phase one all subjects offered are compulsory. The table however, reflects that the emphasis is on First Language (English), Mathematics and Writing in classes 1 and 2. In standard one Second Language (Afrikaans) is also introduced. The weekly time allocation for standard one is three hundred minutes more than that for classes 1 and 2.

2.3.2 Promotion in phase one

Assessment of the pupil's work in phase one is done mainly by the class teacher. The class teacher's assessment may, however, be moderated by the Head of Department for the Junior Primary Phase. There are no formal tests or examinations which pupils have to undergo. All assessment in this phase is done informally.

Basically a knowledge of general mathematics, main language (English) and Writing is necessary for a child to be promoted into the next class. In General Mathematics there are 30 units of work for class 1. A pupil to be promoted into class 2 is expected to know 28 units. Apart from general mathematics the pupil is expected to perform competently in Flash Work, Phonic Work and Comprehension. Competence in Writing is also considered. (25) In standard 1 pupils write short informal tests throughout the year. On the basis of the performance of pupils in these tests, they are either promoted into standard 2 or have to repeat standard 1.

It must however be pointed out that the teacher's assessment of pupils work plays a vital role in the promotion or retardation of pupils in this phase. The table below reflects the total enrolment in each of the classes in phase 1, the percentage pass and the percentage failure for 1977, in Indian schools in the Republic of South Africa. (26)

TABLE 2.3

TOTAL ENROLMENT, PERCENTAGE PASS AND PERCENTAGE FAILURE
FOR 1977 IN PHASE ONE (27)

	TOTAL	PASS		FAIL	
		No	%	No.	%
Class 1	22860	20868	91,3	1992	8,7
Class 2	21146	19528	92,3	1618	7,7
Std. 1	20249	18934	93,5	1315	6,5
Total Phase 1	64255	59330	92,3	4925	7,7

The figures reflected in the table are as at 30 November 1977.

The failure rate of 8,7% and 7,7% in classes 1 and 2 may be attributed to the presence of both mentally retarded and physical handicapped children. These children are normally discovered in the first two years of their schooling before special provision can be made for them in special schools or adjustment classes.

2.4 CURRICULA, FIELD OF STUDY AND PROMOTION REQUIREMENTS IN THE SENIOR PRIMARY PHASE

2.4.1 Curricula and field of study

Table 2.4 reflects the subjects taught and the weekly time allocation for standards 2, 3 and 4.

TABLE 2.4

SUBJECTS AND WEEKLY ALLOCATION OF TIME FOR THE
SENIOR PRIMARY PHASE (28)

SUBJECT	STD. 2 MINUTES PER WEEK	STD. 3 MINUTES PER WEEK	STD. 4 MINUTES PER WEEK
First Language (English)	360(12)	360(12)	360(12)
Second Language (Afrikaans)	210 (7)	240 (8)	240 (8)
General Mathematics	270 (9)	270 (9)	270 (9)
History	60 (2)	60 (2)	60 (2)
Geography	60 (2)	60 (2)	60 (2)
Elementary Science	60 (2)	60 (2)	60 (2)
Health Education	30 (1)	30 (1)	30 (1)
Physical Education	60 (2)	60 (2)	60 (2)
Music	60 (2)	60 (2)	60 (2)
Art	60 (2)	60 (2)	60 (2)
Handicrafts/Needlework	60 (2)	60 (2)	90 (3)
Right Living	60 (2)	60 (2)	90 (3)
Writing	60 (2)	60 (2)	60 (2)
Guidance	30 (1)	30 (1)	30 (1)
Library	30 (1)	30 (1)	30 (1)
Assembly	30 (1)	30 (1)	30 (1)
TOTAL	1 500(50)	1 500(50)	1 500(50)

Figures in brackets shown after the time allocation indicate the number of half-hour periods per week. Formal writing is not taught in standard four.

The table reflects that the emphasis in this phase is also on English, Mathematics and Afrikaans.

In phase two all subjects offered are compulsory; here again there are no particular fields of study that pupils may follow. This phase aims at developing those skills that will give the pupils the necessary background to undertake secondary education profitably.

2.4.2 Promotion in phase two

The assessment of pupils' work in standard 2 is largely based on teacher-made classroom tests. In the course of the year, the teacher constructs a number of tests which are moderated by the administrative staff (Principal, Deputy Principal, Head of Department) at a school. The cumulative results of these tests are considered for promotion to standard 3 together with the teacher's overall assessment in the pupil's general classroom performance. In standard 2 the tests serve as informal examinations.

The emphasis in standard two is still on General Mathematics, Writing and Reading. ⁽²⁹⁾ Afrikaans is of importance as well because 210 minutes out of a possible 1500 minutes per week is allocated to Afrikaans. For promotion purposes pupils performance in Afrikaans does not count.

Assessment of pupils attainment in standards 3 and 4 is based on formal tests given during the year and on two formal examinations. The routine classroom tests as well as the tests for the examinations are normally constructed by the class teacher or subject teacher. These tests are moderated by personnel from the administrative staff. The procedure employed in the construction, administration and marking of tests for an examination have been dealt with in Chapter one.

In standard 3 pupils for the first time in their school career encounter the formal examination. The examinations are written by standards 3 and 4 pupils, one in June and one in November/December of the same school year. The mark allocation for the various subjects in standards 3 and 4 are the same. In the June examination pupils are tested on work covered during the first half of the year. In the November/December examination pupils are tested on work covered during the whole year. The following is a summary of the requirements for promotion of pupils from standard three into standard four and from standard four into standard five. ⁽³⁰⁾

(a) The subjects examined for promotion purposes and the marks assigned to each are as follows:

1	English First Language	240 marks
2	Afrikaans Second Language	180
3	General Mathematics	180
4	Elementary Science	60
5	History	60
6	Geography	60
	Total	<u>780</u>

(b) The subjects are grouped as follows:

- Group 1 English First Language
- Group 2 Afrikaans Second Language
- Group 3 General Mathematics
- Group 4 Elementary Science, History and Geography.

(c) The minimum requirements for promotion are as follows:

	Marks	%
1 Group 1	96	40
2 Each of two of the remaining groups	72	40
3 Aggregate	312	40

Table 2.5 reflects the enrolment, percentage pass and failure in phase two in Indian Schools for 1977

TABLE 2.5

ENROLMENT, PERCENTAGE PASS AND PERCENTAGE FAILURE
IN PHASE TWO IN 1977 ⁽³¹⁾

	TOTAL	PASS		FAIL	
		NO.	%	NO.	&
Std 2	20 007	18 882	94,4	1 125	5,6
3	20 290	18 380	90,6	1 910	9,4
4	18 707	17 155	91,7	1 552	8,3
Total Phase 2	59 004	54 417	92,2	4 587	7,8

The relatively high incidence of failure in standards 3 and 4 is due to the fact that pupils have for the first time come up against the formal examination.

2.5 CURRICULA, FIELD OF STUDY AND PROMOTION REQUIREMENTS IN THE JUNIOR SECONDARY PHASE

2.5.1 Curricula and field of study

The programme is designed "to assist the child to obtain clarity of his ability and his future direction of study by opening the world of knowledge to him and helping him to establish a clearer picture of his potential. The main function of this phase is to enable valid assessments to be made about the child's aptitudes, skills, interests and abilities". (32)

Table 2.6 reflects the subjects taught and the weekly time allocation for standards 5, 6 and 7.

TABLE 2.6

SUBJECTS AND WEEKLY ALLOCATION OF TIME FOR THE JUNIOR SECONDARY PHASE (ACADEMIC COURSE) (33)

SUBJECT	STANDARD 5	STANDARD 6		STANDARD 7	
	(30 min- ute per- iods)	(30 min- ute per- iods)	(35 min- ute per- iods)	(30 min- ute per- iods)	(35 min- ute per- iods)
a. Compulsory Examination Subjects					
1. First Language	330(11)	240 (8)	245 (7)	240 (8)	245 (7)
2. Second Language	240 (8)	210 (7)	210 (6)	210 (7)	175 (5)
3. General Mathematics	270 (9)	210 (7)	210 (6)	180 (6)	140 (4)
4. History	90 (3)	150 (5)	140 (4)	150 (5)	140 (4)
5. Geography	90 (3)	150 (5)	140 (4)	150 (5)	140 (4)
6. General Science	90 (3)	150 (5)	140 (4)	150 (5)	140 (4)
7. Technical Orientation for boys or Domestic Science Orientation for girls: Handicrafts) or) Industrial Arts) or) Housecraft) - or) Needlework and) Garment Making)		150 (5)	140 (4)	120 (4)	140 (4)
8. Commercial Orientation for boys and girls: Accounting	-	120 (4)	140 (4)	120 (4)	140 (4)
9. <u>One</u> Optional Subject from: Latin Physiology Typewriting Technical Drawing Music Art	-	-	-	120 (4)	140 (4)

1110(37) 1380(46) 1365(39) 1440(48) 1400(40)

b. Compulsory Non-Examination Subjects					
1. Handicrafts/ Needlework	60 (2)	-	-	-	-
2. Physical Education	60 (2)	60 (2)	80 (2)	30 (1)	35 (1)
3. Music	60 (2)	30 (1)	35 (1)	30 (1)	35 (1)
4. Art	60 (2)	30 (1)	35 (1)	30 (1)	35 (1)
5. Guidance	30 (1)	30 (1)	35 (1)	30 (1)	35 (1)
6. Library	30 (1)	30 (1)	35 (1)	30 (1)	35 (1)
7. Right Living	60 (2)	60 (2)	+ 75(5 at 15 mins)	30 (1)	+ 75(5 at 15 mins)
8. Assembly	30 (1)	30 (1)	-	30 (1)	-
TOTAL	1500(50)	1650(55)	1575(45) + +75	1650(55)	1575(45) + +75
			<u>1650</u>		<u>1650</u>

Figures in brackets shown after the time allocation indicate the number of periods per week in the relevant subject(s).

Both 30 minute and 35 minute periods are indicated for Standards 6 and 7. Where the highest class in a school is not above Standard 7, the school operates on 30 minutes periods.

Where the highest class in a school is above Standard 7, all classes above Standard 5 operate on 35 minute periods and classes up to and including Standard 5 operate on 30 minute periods.

Table 2.7 reflects subjects, weekly periods and time allocation, the compulsory and non compulsory subjects for the practical course.

TABLE 2.7

SUBJECTS AND WEEKLY ALLOCATION OF THE TIME FOR THE PRACTICAL COURSE (34)

STANDARDS VI AND VII

SUBJECT	STANDARD 6		STANDARD 7	
	30 min. periods	35 min. periods	30 min. periods	35 min. periods
a. Compulsory Examination Subjects:				
1. First Language	210 (7)	210 (6)	210 (7)	210 (6)
2. Second Language	180 (6)	175 (5)	210 (7)	175 (5)
3. Practical Mathematics	150 (5)	140 (4)	120 (4)	140 (4)
4. General Science	150 (5)	140 (4)	120 (4)	140 (4)
5. History	120 (4)	140 (4)	120 (4)	105 (3)
6. Geography	120 (4)	140 (4)	120 (4)	105 (3)
7.) <u>Three</u> vocation-	150 (5)	140 (4)	180 (6)	175 (5)
8.) <u>ally</u> directed	150 (5)	140 (4)	180 (6)	175 (5)
9.) subjects from Industrial Arts. Commercial subjects Domestic science	150 (5)	140 (4)	180 (6)	175 (5)
	1380(46)	1365(39)	1440(48)	1400(40)
b. Compulsory Non-Examination Subjects:				
1. Physical Education	60 (2)	70 (2)	30 (1)	35 (1)
2. Music	30 (1)	35 (1)	30 (1)	35 (1)
3. Art	30 (1)	35 (1)	30 (1)	35 (1)
4. Guidance	30 (1)	35 (1)	30 (1)	35 (1)
5. Library	30 (1)	35 (1)	30 (1)	35 (1)
6. Right Living	60 (3)	75(15 min per day	30 (2)	75(15 min per day
	1650(55)	1575(45) + 75	1650(55)	1575(45) + 75
		1650		1650

The tables reflect that the emphasis in this phase is also on English, Mathematics and Afrikaans. Although English and Mathematics are emphasised throughout the system, there is a tremendous failure rate in these subjects. This will be discussed later in this chapter. In standards 6 and 7 pupils are offered a certain number of compulsory examination subjects and a choice from a group of optional subjects. The pupil normally choose a subject in a field of study that interests him. The subject offered as a choice to pupils is also tested in examinations. The subject is also considered in the aggregate.

In the Junior Secondary Phase use has been made of the terms academic and practical courses. It is considered necessary to explain these terms before proceeding to the promotion requirements in this phase. The Academic Course is a course designed for the normal child with an I.Q. of above 90+. (35) Pupils taking this course eventually sit for the Senior Certificate Examination. These pupils are potential university or tertiary education material. The Practical Course, on the other hand, is a course of study designed for the dull normal child (I.Q. range from 85-89). This course is designed to accommodate about 20% of the pupils in Indian schools. There is divergency of views as to the percentage of children that fall within this category. Some educators (Behr (1971) Muller (1968)) are of the opinion that this course should cater for \pm 16% of the secondary school population. (36)(37)

2.5.2 Promotion requirements in phase three

The promotion in phase 3 is discussed separately for each standard. Pupils following the academic course can either pass into the academic course or practical course depending on their performance in the examinations.

Promotion in standard 5

- a. The subjects examined for promotion purposes and the marks assigned to each is as follows: (38)

1. English First Language	300	marks
2. Afrikaans Second Language	200	"
3. General Mathematics	100	"
4. General Science	100	"
5. History	100	"
6. Geography	100	"

- b. The subjects are grouped as follows:

- Group 1 English First Language
 Group 2 Afrikaans Second Language
 Group 3 General Mathematics and General Science
 Group 4 History and Geography

- c. The minimum requirements for promotion are as follows:

	Pass into Std 6 Academic Course		Pass into Std 6 Practical Course	
	Marks	%	Marks	%
1. Group 1	135	45	105	35
2. Each of two of the remaining groups	80	40	70	35
3. Aggregate	450	50	315	35

- d. A pupil who is promoted into Standard 6 in the Practical Course, or who fails, may repeat Std. 5.

A point worthy of mention here is the pass requirements for pupils in standard 5. Pupils passing into the standard 6 academic course are required to obtain 45% in English and an aggregate of 50%. In all other standards pupils passing into the academic course are required to obtain 40% in English and in the aggregate. The standard 5 examination,

being the first selection examination that decides whether a pupil should follow the academic or practical course, should therefore be a little lenient in the pass requirements for the academic level.

Promotion in standard 6 and 7 academic course

The subjects offered and the promotion requirements for standards 6 and 7 academic course are the same.

a. The subjects examined for promotion purposes and the marks assigned to each is as follows: (39)

1. English First Language	400 marks
2. Afrikaans Second Language	300 "
3. General Mathematics	150 "
4. General Science	150 "
5. History	150 "
6. Geography	150 "
7. One from:-	
(i) Technical Drawing)
(ii) Industrial Arts (boys))
(iii) Housecraft (girls)) 100 marks
(iv) Needlework and Clothing (girls))
(v) Home Economics)
8. Accountancy or Typing	100 marks
9. One from:-	
(i) Latin)
(ii) Arabic)
(iii) Hindi)
(iv) Art)
(v) Music) 100 marks
(vi) Health Education)
(vii) a subject not already taken from groups 7 or 8))

b. The subjects are grouped as follows:

- Group 1 English First Language
- Group 2 Afrikaans Second Language
- Group 3 General Mathematics and General Science
- Group 4 History and Geography
- Group 5 Subject chosen from 7, 8 and 9 in (a) above.

The pass requirements from standard 6 into standard 7 and from standard 7 into standard 8 are given in table 2.8.

PASS REQUIREMENTS IN STANDARDS 6 AND 7 FOR PROMOTION INTO THE NEXT HIGHER CLASS (40)

SUBJECT GROUPS	STANDARD 6				STANDARD 7			
	ACADEMIC	PASS	PRACTICAL	PASS	ACADEMIC	PASS	PRACTICAL	PASS
	MARK	%	MARK	%	MARK	%	MARK	%
1. Group 1	160	40	120	30	160	40	120	30
2. Each of THREE of the remaining groups.	120	40	90	30	120	40	90	30
3. Aggregate	640	40	480	30	640	40	480	30

- NOTE: a. A pupil who follows the Academic Course in Standard 6 and who is promoted into Standard 7 Practical Course, may repeat Standard 6 Academic Course if he so desires.
- b. A pupil who follows the Academic Course in Standard 6 and who fails may repeat Standard 6 Academic.
- c. A pupil who follows the Academic Course in Standard 7 and who is promoted into Standard 8 in the Practical Course, may repeat Standard 7 Academic.
- d. A pupil who follows the Academic Course in Standard 7 and who fails may repeat Standard 7 Academic.

Promotion requirements from standards 6, 7 and 8 (Practical Course)

- a. The subjects examined for promotion purposes and the marks assigned to each are as follows: (41)

1. English First Language	300 marks
2. Afrikaans Second Language	300 marks
3. Practical Mathematics	150 marks
4. General Science	150 marks
5. History	150 marks
6. Geography	150 marks
7. 8 and 9: <u>Three</u> of the following subjects of which at least two must be from the <u>same</u> director of study: 3 x 100	300 marks

7. TECHNICAL	8. COMMERCIAL	9. DOMESTIC SCIENCE
Workshop Practice	Accounting	Cookery and Home Management
Workshop Theory	Business Methods	Mothercraft and Hygiene
Industrial Arts	Salesmanship	Housecraft
Technical Drawing	Typing	Needlework and Garment making

- b. The subjects are grouped as follows:

Group 1	English First Language
Group 2	Afrikaans Second Language
Group 3	Practical Mathematics and General Science
Group 4	History and Geography
Group 5	The subjects chosen from 7, 8 and 9 in (a) above.

- c. The minimum requirements for promotion are as follows:

1. Group 1	120 marks
2. Each of three of the remaining groups	120 marks
3. Aggregate	600 marks

- d. A pupil following the Practical Course in any Standard who fails may repeat the standard in the Practical Course.
- e. A pupil following the Practical Course in Standards VI and VII and who passes may: (i) be promoted to the Academic Course in the next standard, provided he scores 180 marks in English and obtains an aggregate of 720 marks for groups 1, 2, 3 and 4; (ii) repeat the standard in the Academic Course; (iii) be promoted to the Practical Course in the next standard.
- f. A pupil following the Practical Course in Standard VIII and who passes may continue his/her schooling by repeated Standard VIII in the Academic Course.

Table 2.9 reflects the enrolment, percentage pass and percentage failure in phase 3 in 1977.

TABLE 2.9

ENROLMENT, PERCENTAGE PASS AND FAILURE IN PHASE THREE IN 1977 (42)

STANDARD	ENROLMENT	PASS ACADEMIC		PASS PRACTICAL		FAILURE	
		NO.	%	NO.	%	NO.	%
5	16320	10887	66,7	4778	29,3	655	4,0
6 Academic	10629	8453	79,5	1905	27,9	271	2,6
6 Practical	4297	101	2,3	3865	90,0	331	7,7
7 Academic	7825	5991	76,6	1564	20,0	271	3,4
7 Practical	4925	64	1,3	4023	81,7	838	17,0

Of the pupils in the academic stream, the outright failure in 1977 was 2,62% in standard 6 and 3,4% in standard 7. However those that followed the practical course fared badly and some 17% failed outright in standard 7. Comment will be made on this aspect in a subsequent paragraph.

It is in this phase that teachers are faced with the problem of making decisions on whether a pupil should be promoted into the practical or academic courses. By and large their decisions are based on the measurable outcome of education i.e. performance of

pupils in the June and November/December school examinations. The writer feels that any decision based solely on examination results, and which categorises pupils into a practical or academic type of education, must be based on more than just examination results. The examination results together with I.Q. scores, aptitude test scores, records of emotional and social adjustment, and environmental factors must be considered when arriving at a decision as to whether a pupil should be placed into the academic or practical courses. McClelland (1949) and McIntosh (1949) after conducting an extensive experiment on selection for secondary education conclude that "on no account should the results of one test or examination be used to select pupils for secondary courses of instruction". Among the measures which are most useful for selection are: intelligence tests, teachers estimates and personal qualities. (43)(4)

2.6 CURRICULA, FIELD OF STUDY AND PROMOTION REQUIREMENTS IN THE SENIOR SECONDARY PHASE

2.6.1 Curricula and field of study

The curriculum during this phase provides for extensive differentiation by offering various fields of study and in certain approved subjects, within the field of study, subjects are offered at a higher as well as at a standard level. The subjects taught at two levels are examined at two levels at the end of this phase. (45)

Table 2.10 reflects the weekly time allocation for subjects taught on the academic level in this phase.

TABLE 2.10

WEEKLY ALLOCATION OF TIME FOR THE SENIOR SECONDARY PHASE -
ACADEMIC COURSE (46)

SUBJECT	STANDARDS VIII, IX AND X (35 minute periods) MINUTES PER WEEK	
	Minutes per week	Periods
(a) <u>Compulsory Examination Subjects:</u>		
1. First Language	315	9
2. Second Language	280	8
3.) <u>Four examination sub= jects selected in</u>	210	6
4.) <u>terms of the courses</u>	210	6
5.) <u>approved for the</u>	210	6
6.) <u>school - 6 periods</u> <u>per subject (6 x 4)</u>	210	6
Optional period to be added to a weak subject	35	1
	1470	42
(b) <u>Compulsory Non-Examina= tion Subjects:</u>		
1. Physical Education	35	1
2. Guidance	35	1
3. Library	35	1
4. Right Living (15 min. per day)	+ 75	
TOTAL	1650	45

NOTE: 1. All classes in the Senior Secondary Phase
operate on 35 minute periods - 9 periods per day.

Apart from English and Afrikaans which enjoy more time, all subjects in the senior secondary phase have the same amount of time allocated to them.

Having considered the weekly allocation of time for subjects in the senior secondary phase (academic course) it becomes necessary to list the fields of study offered.

Fields of study:

The following fields of study are offered in the senior secondary phase. (47)

1. General
2. Humanities
3. Natural Science
4. Commercial
5. Home Economics (Domestic Science)
6. Technical

The Department of Indian Affairs offers 40 subjects in 146 different combinations in the senior secondary phase. (48)

The subjects offered and the number of students taking each in 1977 are listed in table 2.11.

TABLE 2.11

SUBJECTS AND THE NUMBER OF PUPILS TAKING EACH IN STANDARDS 8, 9 AND 10 IN 1977. (49)

GROUPS/SUBJECTS	STANDARDS					
	8		9		10	
	NO.	%	NO.	%	NO.	%
GROUP A						
Afrikaans HG	6591	83,3	5117	80,1	4140	83,3
English HG	7225	91,3	5401	84,5	4265	85,8
Afrikaans SG	1324	16,7	1274	19,9	831	16,7
English SG	690	8,7	990	15,4	706	14,2

GROUP B

Mathematics HG	4438	56,1	2863	44,8	2066	41,6
Mathematics SG	664	8,4	1362	21,3	1686	33,9

GROUP C

Physical Science HG	1995	25,2	1670	26,1	1402	28,2
Physical Science SG	253	3,2	368	5,8	332	6,7
Biology HG	5039	63,7	3512	55,0	2992	60,2
Biology SG	718	9,1	1167	18,3	905	18,2

GROUP D

Latin HG	-	-	-	-	27	0,5
Arabic SG	15	0,2	-	-	-	-

GROUP E

History HG	2054	26,0	1747	27,3	1548	31,1
History SG	341	4,0	507	7,9	410	8,2
Geography HG	1809	22,9	1462	22,9	1071	21,5
Geography SG	228	2,9	392	6,1	494	9,9
Economics HG	927	11,7	569	8,9	378	7,6
Economics SG	142	1,8	135	2,1	71	1,4
Music HG	58	0,7	33	0,5	-	-
Music SG	11	0,1	-	-	-	-
Art SG	20	0,3	-	-	-	-

GROUP F

Accountancy HG	5316	67,2	3496	54,7	2305	46,4
Accountancy SG	1477	18,7	1950	30,5	1774	35,7
Business Economics SG	1808	22,8	1357	21,2	671	13,5
Home Economics HG	103	1,3	87	1,4	69	1,4
Home Economics SG	26	0,3	2	0,03	1	0,02
Technical Drawing HG	231	2,9	155	2,4	59	1,2
Technical Drawing SG	149	1,8	120	1,9	33	0,7
Woodwork SG	291	3,7	264	4,1	92	1,9
Metalwork SG	57	0,7	28	0,4	25	0,5
Needlework and Clothing SG	105	1,3	72	1,1	31	0,6
Housecraft SG	519	6,6	460	7,2	333	6,7
Mercantile Law SG	137	1,7	32	0,5	20	0,4
Commercial Maths SG	27	0,3	14	0,2	26	0,5
Typing SG	2315	29,2	1594	24,9	954	19,2
Motor Mechanics SG	147	1,9	109	1,7	37	0,7

Woodworking SG	93	1,2	70	1,1	30	0,6
Welding & Metalworking SG	16	0,2	1	0,01	1	0,02
Bricklaying and Plastering SG	6	0,1	2	0,03	-	-
Radiotrician SG	1	0,01	10	0,2	3	0,06
Electrician Work SG	32	0,4	12	0,2	5	0,1
Fitting and Turning SG	27	0,3	13	0,2	2	0,04
Plumbing and Sheet= metal SG	10	0,1	7	0,1	1	0,02

The table also gives some indication of the differentiation that takes place in the senior secondary phase.

Subjects in the commercial and science fields of study seem to be very popular among Indian pupils. Subjects in the Technical field of study are offered in only four of the Departments Secondary Schools. These schools have large workshops to cater for the technical subjects. Previously technical subjects did not attract many pupils because there was feeling that a technical type of education was inferior; further more the availability of work in the technical field for Indians was minimal. This trend however is changing rapidly. The number of children taking technical subjects has increased tremendously in recent years. Mention must be made of the introduction of Indian languages for the Senior Certificate Course. Arabic is offered at the standard 8 level, the demand for this subject is still small. The demand for Latin is dropping each year.

The time allocation and subjects offered in the practical course are now discussed.

Table 2.12 reflects the subjects and the weekly time allocation for standard 8 practical course.

TABLE 2.12

SUBJECTS AND WEEKLY TIME ALLOCATION FOR STANDARD EIGHT -
PRACTICAL COURSE (50)

SUBJECTS	TIME ALLOCATION (35 min. periods)	
	Minutes	Periods
(a) Compulsory Examination Subjects:		
1. First Language	210	6
2. Second Language	175	5
3. Practical Mathematics	140	4
4. General Science	140	4
5. History	105	4
6. Geography	105	3
7.) Three vocationally 8.) directed subjects	175	5
9.) selected from: Industrial Arts Domestic Science Commercial Subjects	175	5
	1400	40
(b) Compulsory Non-Examination Subjects		
1. Physical Education	35	1
2. Music	35	1
3. Art	35	1
4. Guidance	35	1
5. Library	35	1
6. Right Living	75 (15 min periods)	
	1575	45
	+ 75	
	1650	

Table 2.13 reflects the weekly allocation of time for subjects in standards 9 and 10 practical course.

TABLE 2.13

WEEKLY ALLOCATION OF TIME FOR SUBJECTS IN STANDARDS 9 AND 10 - PRACTICAL COURSE (51)

SUBJECTS	TIME ALLOCATION	
	Minutes	Periods
Group 1 : First Language	175	5
Second Language	175	5
Group 2 : Two subjects	350	10
Group 3 : Two subjects	700	20
Non-examination subjects:		
Physical Education	35	1
Guidance	35	1
Library	35	1
Music	35	1
Art	35	1
Right Living	75 per week	
Total Time	1650	45

The subjects are grouped as follows:

Group 1 : Both official languages must be offered.

English/Afrikaans - First Language (Practical)

Afrikaans/English - Second Language (Practical).

Group 2 : Two of the following subjects must be chosen

Mathematics (Practical)

Physical Science (Practical)

Biology (Practical)

History-Geography (one subject)(Practical)

Business Economics (Practical)

Group 3 : (a) General Direction of Study

Two of the following subjects may be chosen

Woodwork Theory Practical
 Woodwork Practice Practical
 Metalwork Theory Practical
 Metalwork Practice Practical
 Housecraft Practical
 Mothercraft Practical
 Typing Practical
 Accountancy Practical
 Business Methods Practical

or

(b) Technical Direction of Study

Two of the following subjects may be chosen

Motor Mechanics Theory Practical
 Motor Mechanics Practice Practical
 Bricklaying and Plastering Theory Practical
 Bricklaying and Plastering Practice Practical
 Radiotrician-work Theory Practical
 Radiotrician-work Practice Practical
 Fitting and Turning Theory Practical
 Fitting and Turning Practice Practical
 Woodworking Theory Practical
 Woodworking Practice Practical
 Welding and Metalworking Theory Practical
 Welding and Metalworking Practice Practical
 Plumbing and Sheetmetalworking Theory Practical
 Plumbing and Sheetmetalworking Practice Practical
 Electrician-work Theory Practical
 Electrician-work Practice Practical

The number of pupils in the standard 9 practical course in 1978 and the number taking the various subjects is given in the table below.

TABLE 2.14

NUMBER OF PUPILS TAKING THE VARIOUS SUBJECTS IN STANDARD 9
PRACTICAL COURSE IN 1978 (52)

	NO.	% OF PUPILS
Afrikaans 2nd Language - Practical	2738	100
English 1st Language - Practical	2738	100
Mathematics - Practical	1642	60,0
Physical Science - Practical	441	16,1
Biology - Practical	1193	43,6
History/Geography - Practical	1003	36,6
Business Economics - Practical	1005	36,7
Woodwork - Theory/Practice - Practical	130	4,7
General Science	150	5,5
Metalwork - Theory/Practice - Practical	82	3,0
Housecraft - Practical	411	15,0
Typing - Practical	1094	40,0
Accountancy - Practical	1935	70,7
Business Methods - Practical	1141	41,7
Motor Mechanics - Theory/Practice - Practical	54	2,0
Bricklaying & Plastering - Theory/Practice - Practical	14	0,5
Radiotrician work - Theory/ Practice - Practical	16	0,5
Motor Body Repairing - Theory/ Practice - Practical	20	0,7
Fitting & Turning - Theory/Practice - Practical	21	0,8
Woodworking - Theory/Practice - Practical	87	3,2
Welding & Metalworking - Theory/ Practice - Practical	25	0,9
Plumbing & Sheetmetalworking - Theory/Practice - Pratical	17	0,6
Electrician work - Theory/Practice - Practical	14	0,5

From the table it is quite clear that very few pupils are taking the technical subjects. The availability of facilities at schools restricts the number of pupils that may offer technical subjects. Apart from English and Afrikaans which are compulsory subjects, subjects in the commercial study direction are most popular.

The number of subjects offered in the Senior Secondary Phase allows for extensive differentiation. It must, however, be pointed out that it is not always possible in a school to offer all the various fields of study. The demand by pupils and economic factors are considered when a new field of study is introduced.

2.6.2 Promotion requirements in phase four

Assessment of pupils' work in standards eight and nine is done generally by subject teachers. The teacher, however, makes his assessment on the examinations written by the pupils. Here again pupils write two examinations - one in June and the other in November/December of the same year. Promotion of pupils into the next standard is based on the combination of pupils' performance in the two examinations. The examination procedure is explained in chapter one. The promotion requirements for standards 8, 9 and 10, academic course, is now considered.

Promotion from standard 8 and 9 (academic course)

- a. The mark allocation for the subjects taken in the different courses is: (53)

Subjects taken on the Higher Grade (except Afrikaans)	400 marks
Subjects taken on the Standard Grade	300 marks
Afrikaans Second Language Higher Grade	300 marks



b. The requirements for passing are:-

i. In Individual Subjects: A minimum of 160 marks in subjects taken on the Higher Grade (except Afrikaans Second Language which is 100 marks) and a minimum of 100 marks in subjects taken on the Standard Grade.

ii. In the Examination as a whole

1. A pass in English First Language Higher or Standard Grade.

2. A pass in Afrikaans Second Language Higher or Standard Grade.

A pass in THREE other subjects on either Higher or Standard Grade, including a converted standard Grade pass as set out in (c) below.

3. And a minimum aggregate of 720 marks.

c. A failure in a subject taken on the Higher Grade (Afrikaans Second Language excepted) is converted to a pass on the Standard Grade provided a minimum of 100 marks is obtained in that subject. In the case of Afrikaans Second Language Higher Grade 90-99 marks is converted to a pass in Afrikaans Second Language Standard Grade. (54)

Promotion in standard 10

The Standard 10 Examination is an external examination written by all Standard 10 pupils of that year. The examination is instituted under section 21(3) of the Indian Education Act, 1965 (Act No. 61 of 1965). (55) The examination is conducted and controlled by the Division of Education of the Department of Indian Affairs. The Department of Indian Affairs issues the Senior Certificates to all successful candidates.

The examination pass requirements for the senior certificate examination are the same as for standards 8 and 9. Pupils that enter for the senior certificate with matriculation exemption pass, must however fulfil the requirements for Matriculation Exemption as laid down by the Joint Matriculation Board. It is not intended to discuss the requirements for matriculation exemption in this work. The requirements are found in the Joint Matriculation Handbook which is issued yearly. (56)

The promotion requirements for standards 8, 9 and 10, practical course will now be discussed

Promotion requirements for standard 8 (Practical Course)

The promotion requirements for standard 8 (practical course) has been dealt with under paragraph 2.5.24. The requirements for standard 8 (practical course) are the same as that for standard 6 and 7 (practical course).

Promotion requirements for standards 9 and 10 (practical course)

The maximum mark awarded for each subject is 400. Three hundred of the 400 marks are awarded as a year mark. At the end of the year in standards 9 and 10 pupils write an examination (theory paper) constituting 100 marks.

Requirements for passing (57)

In individual subjects: a minimum of 30 marks in the theory paper and 160 marks in the combined theory paper and year mark aspects of the subject.

In the Examination as whole: A pass in English, Afrikaans, three other subjects and a minimum aggregate of 960 marks (40%).

The standard 10 (practical course) examination will be written by candidates for the first time in November/December 1979. The question papers will be set by the Department of Indian Affairs. A time-table indicating the day, time and subjects to be written will be issued to every candidate. The marking of scripts will be undertaken by teachers in the school, the Department will supply marking memoranda. Once the scripts have been marked, they will be submitted to the Department. The Department will determine results and issue certificates.

Table 2.15 reflects the enrolment, percentage pass and failure in phase 4 in Indian Schools in 1977. ⁽⁵⁸⁾ This table does not include figures for standards 9 and 10 (practical course). The standard 9 practical course was introduced at the beginning of 1978. ⁽⁵⁹⁾

TABLE 2.15

ENROLMENT, PERCENTAGE PASS AND FAILURE IN PHASE 4 IN INDIAN SCHOOLS IN 1977 ⁽⁶⁰⁾

STANDARD	TOTAL	ACADEMIC PASS		PRACTICAL PASS		FAILURE	
		NO.	%	NO.	%	NO.	%
8 Academic	7346	6302	85,8	-	-	1044	14,2
8 Practical	4510	-	-	3785	83,9	724	16,1
9 Academic	6023	4719	78,3	-	-	1304	21,7
10 Academic	4839	4315*	89,2	-	-	524	10,8

* of the 4315 pupils who passed the senior certificate, some 29% only passed with matriculation exemption.

The table reflects an unusually high failure rate in phase 4, the highest being in standard 9. This may be attributed to the fact that schools aim at obtaining good results in the Senior Certificate examination, therefore pupils are failed in standard 9.

Another point worthy of comment is the high failure rate in the standard 8 practical course. At this stage a possible reason for such a high failure rate cannot be given.

2.7 AN ASSESSMENT OF THE FOUR PHASE SYSTEM OF DIFFERENTIATED EDUCATION

From the foregoing it has become clear that the system of differentiated education as implemented in Indian Education is a complicated and elaborate system. Having set out in detail the whole procedure class by class, it is now necessary to examine the system critically.

It has become clear that the teacher plays a vital role in the assessment of pupils' work in Indian schools. Practical, Oral and Written forms of assessment are done mainly by teachers. It is only in the Senior Certificate Examination that the teacher has little say in the assessment of pupils' work. It must also be mentioned that when the promotion of pupils from one class to the next is decided, tremendous importance is placed on pupils' attainment in examinations. The teacher uses the examination mainly as a means for promoting and retarding pupils.

Notwithstanding the high degree of differentiation in subject choice particularly in phase 4, and the assessment of pupils work being in the hands of teachers, it would seem that the overall failure rate throughout the school system is high. Considering the fact that the differentiated system of education was instituted to cater for the interests, aptitudes and abilities of pupils, one would expect failure to be minimal. A 17% failure rate in standard 7 practical (Table 2.9) and 16,1% failure rate in standard 8 practical (Table 2.15) leads one to conclude that the practical course is not fulfilling its intended purpose.

Further, a consideration of the failure rates in standard 8, 9, 10 academic course (Table 2.15) questions the type of differentiation taking place in phase 4. Noting the fact that 40 subjects, some at the Higher and Standard grades are offered in phase 4, one would expect

a negligible failure rate in standards 8, 9 and 10. In the Natal Education Department some 7% of the pupils fail in the three standards combined. (61)

At this stage one needs to trace the percentage of pupils, who, on entering class 1, reach standard 10. Table 2.16 reflects the percentage of pupils that reach standard 10. (In determining the failure rates in each standard the average failure rates of the past three years i.e. 1975, 1976, 1977 were taken into account.)⁽⁶²⁾

TABLE 2.16

PERCENTAGE OF PUPILS WHO ON ENTERING CLASS ONE REACH STANDARD 10

STANDARD	ACADEMIC	PRACTICAL
	%	%
Class i	100	-
Class ii	91	-
Standard 1	84	-
Standard 2	79	-
Standard 3	75	-
Standard 4	68	-
Standard 5	62	-
Standard 6	42	18
Standard 7	28	12
Standard 8	22	6
Standard 9	19	-
Standard 10	15	-

Of the 15 that reach standard 10, 13 pass the senior certificate; and of the 13, five pass with matriculation exemption. A graphic representation of table 13 is given on page 73.

PERCENTAGE OF PUPILS WHO ON ENTERING CLASS ONE IN 1966 REACHED STANDARD 10 IN 1977.

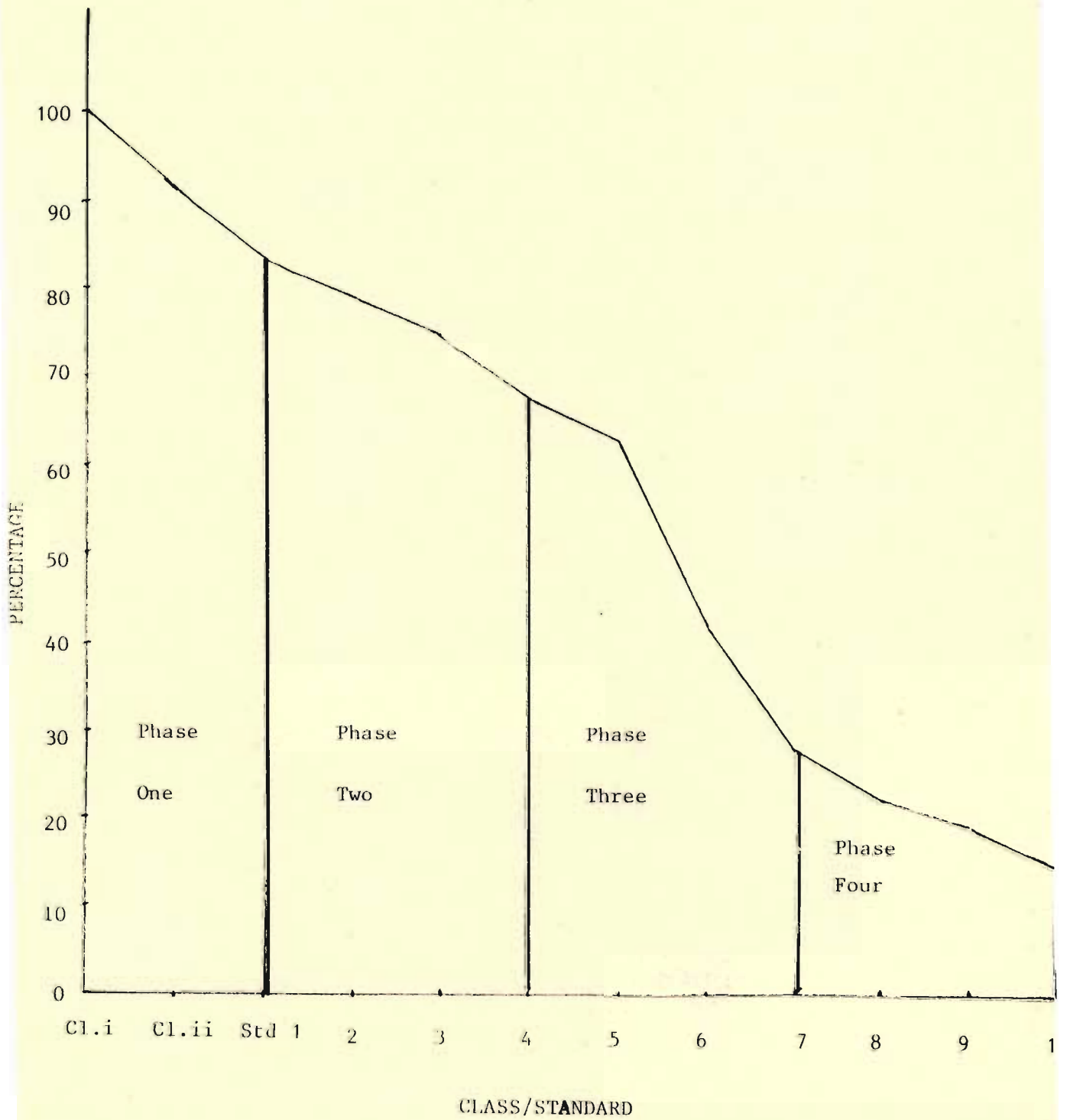

The graph reveals that the greatest failure is at the end of standard 6. In Indian schools the standard 6 year is the first year that pupils spend in secondary schools. One may conclude that the period of transition from primary to secondary education needs to be closely examined to determine possible reasons for the high failure rate. Apart from the high failure, the percentage of pupils passing into the practical course is relatively high.

Having given an overview of the system of differentiated education it becomes necessary to analyse the 1977 examination results of candidates who wrote the academic course but obtained practical passes.

2.8 AN ANALYSIS OF THE 1977 EXAMINATION RESULTS OF STANDARDS 5, 6, AND 7 ACADEMIC COURSE PUPILS WHO OBTAINED PRACTICAL PASSES

An analysis of the promotion and retardation schedules of pupils who wrote the standards 5, 6 and 7 academic course examination in 1977, and who gained practical passes was made. (63)

A random sample of 400 pupils per standard 5, 6 and 7 who obtained practical passes was chosen. The object of this analysis was to determine subjects that pupils failed most.

The table below reflects the percentage of pupils who failed to gain academic passes in the various subjects.

TABLE 2.17

PERCENTAGE OF PUPILS WHO FAILED TO GAIN ACADEMIC PASSES IN SUBJECTS
TAKEN FOR THE 1977 EXAMINATIONS (64)

SUBJECTS	PERCENTAGE THAT FAILED TO GAIN ACADEMIC PASSES		
	Std. 5	Std. 6	Std. 7
English	27,75	35,25	27,75
Afrikaans	5,50	14,50	12,25
Mathematics	65,50	63,25	61,50
General Science	12,25	16,00	15,25
History	5,25	14,25	14,00
Geography	7,50	11,00	14,00
Health Education	-	9,53	8,15
Typing	-	10,47	7,23
Housecraft	-	5,52	5,17
Technical Drawing	-	10,11	12,00
Accountancy	-	14,27	16,73

From the table it can be concluded that Mathematics and English are the problem subjects. The high incidence of failure in English and Mathematics, notwithstanding the greater time allocated to these subjects on the time table is a matter that needs further investigation.

The poor performance in these key subjects accounts in the main for the large number of pupils streamed into the practical classes. It is this discrepancy in performance that has prompted the author of this dissertation to investigate the difference in performance in academic and practical course pupils in these two subjects.

In a further investigation, a random sample of 400 standard 5 pupils who had been placed in the practical course in standard 6 in 1978 was chosen for study. A scrutiny of the results of these 400 pupils indicates that if the pass mark for English was reduced from 45 to 40% (as is the policy in the Natal Education Department), then 7% of the sample of 400 pupils

would have gained academic passes; if the aggregate was reduced from 50% to 40% then 19% of the sample would have gained academic passes.

2.9 PUPILS WRITING THE ACADEMIC COURSE EXAMINATION AND WHO GAIN PRACTICAL COURSE PASSES

Mention has been made earlier in this chapter of the percentage of pupils that ought to be placed in the practical course. Both Behr (1971) and Muller (1968) agree that the practical course pupils should constitute \pm 16% of the secondary school population.

Let us now consider the percentage of pupils that are placed in practical course classes in Indian Secondary Schools. Table 2.18 reflects the number and percentage of pupils that were in the academic and practical course in 1975, 1976 and 1977. (65)

TABLE 2.18

DISTRIBUTION OF ACADEMIC AND PRACTICAL COURSE PUPILS IN STANDARDS 5, 6, 7 BASED
ON THE SCHOOL EXAMINATION RESULTS OF 1975, 1976 AND 1977⁽⁶⁶⁾

STD.	1975								1976								1977							
	ENROL=		ACADEMIC		PRACTICAL		FAIL		ENROL=		ACADEMIC		PRACTICAL		FAIL		ENROL=		ACADEMIC		PRACTICAL		FAIL	
	MENT		NO.	%	NO.	%	NO.	%	MENT		NO.	%	NO.	%	NO.	%	MENT		NO.	%	NO.	%	NO.	%
5	14034	9737	69,39	3755	26,75	542	3,86	12209	8169	66,90	3598	29,47	442	3,63	16320	10887	66,71	4778	29,28	655	4,01			
6	11737	6822	58,13	4284	36,49	631	5,38	12793	7711	60,28	4516	35,30	566	4,42	14826	8554	57,70	5670	38,24	602	4,06			
7	11102	4443	40,02	5335	48,05	1324	11,93	11151	4792	42,98	5244	47,03	1115	9,99	12750	6055	47,49	5586	43,81	1109	8,70			

It is noted from table 2.18 that the percentage of pupils being promoted into the practical course increases progressively from some 25% in Standard 5 to almost 50% in Standard 7. This percentage is far in excess of the pass rate into the practical course as laid down in the Departmental Circular No. 28 of 1972. (I.E. Circular No. 28 of 1972 states that the practical course should constitute $\pm 20\%$ of the secondary school population).

Although there may be variations in the number of pupils passing into the practical course in the different standards, the overall position reflects some consistency. The table below reflects the percentage of pupils in the practical course for three years 1975, 1976 and 1977.

TABLE 2.19

PERCENTAGE OF PUPILS IN THE PRACTICAL COURSE IN THE STANDARD 6,7 AND 8 SCHOOL POPULATION FOR THREE YEARS ⁽⁶⁷⁾

YEARS	PERCENTAGE OF PUPILS IN THE PRACTICAL COURSE
1975	37,09
1976	37,27
1977	37,11

Some 37% of the total standards 6, 7 and 8 school population in 1975, 1976 and 1977 constituted practical course pupils. In this dissertation an attempt will be made to find reasons for the abnormally high number of pupils falling into the practical course in Indian schools.

2.10 GENERAL

From the foregoing, it is clear that the teachers' assessment of pupils based solely on the examination procedure as outlined in this

chapter, tends towards placing an inordinately large number of pupils into the practical stream.

In chapter 3 factors that could influence pupil performance in school examinations and thus result in their being placed into the practical course are discussed.

REFERENCE

1. KROG, G. : "Differentiated Education"- Part I,
Fiat Lux, Vol. 7, No. 1.7,
September 1972 p.18
2. BEHR, A.L. and MACMILLAN, R.C. : Education in South Africa, van
Schaik, Pretoria, 1971 pp. 155-157
3. VAN DER WALT, N. : "Failure at School"- Part II,
Fiat Lux Vol. 7, No. 10, December
1972 pp. 20-22
4. BEHR, A.L. : New Perspectives in South African
Education, Butterworths, Durban
1978 pp. 30-37
5. MALHERBE, E.G. : Education in South Africa - Vol. 2
(1923-1975) Juta and Co., Cape Town,
1977 pp. 349-354
6. BEHR, A.L. : op cit., p. 36
7. BEHR, A.L. and MACMILLAN, R.C. : op. cit., p. 166
8. BEHR, A.L. : op. cit., pp. 30-37
9. MALHERBE, E.G. : op. cit., pp. 349-50
10. REPUBLIC OF SOUTH AFRICA : Government Gazette, Vol. 77
No. 3306 of 12.11.1971
11. BEHR, A.L. and MACMILLAN, R.C. : op. cit., p. 166
12. DEPARTMENT OF INDIAN AFFAIRS - : Circular No. 28 of 1972,
(DIVISION OF EDUCATION) File No. 19/15/6/2
13. KROG, G. : op. cit., p. 18
14. BEHR, A.L. : op. cit., pp. 30-39
15. MALHERBE, E.G. : op. cit., pp. 349-354
16. BEHR, A.L. : op. cit., p. 244
17. DEPARTMENT OF INDIAN AFFAIRS - : Circular No. 28 of 1972,
(DIVISION OF EDUCATION) File No. 19/15/6/2
18. DEPARTMENT OF INDIAN AFFAIRS - : Circular No. 31 of 1972,
(DIVISION OF EDUCATION) File No. 19/15/6/2

19. BEHR, A.L. : op. cit., p. 50
20. DEPARTMENT OF INDIAN AFFAIRS - : Circular No. 28 of 1972,
(DIVISION OF EDUCATION) File No. 19/15/6/2
21. IBID
22. IBID
23. DEPARTMENT OF INDIAN AFFAIRS - : Circular No. 39 of 1973,
(DIVISION OF EDUCATION) File No. 19/16/4
24. IBID
25. DEPARTMENT OF INDIAN AFFAIRS - : Circular No. 11 of 1971,
(DIVISION OF EDUCATION) File No. 19/20/6/1
26. DEPARTMENT OF INDIAN AFFAIRS - : Statistics file No. 19/46/2
(DIVISION OF EDUCATION)
27. IBID
28. DEPARTMENT OF INDIAN AFFAIRS - : Circular No. 39 of 1973,
(DIVISION OF EDUCATION) File No. 19/16/4
29. DEPARTMENT OF INDIAN AFFAIRS - : Circular No. 11 of 1971,
(DIVISION OF EDUCATION) File No. 19/20/6/1
30. DEPARTMENT OF INDIAN AFFAIRS - : Circular Minute AY of 1977,
(DIVISION OF EDUCATION) File No. 1/6/2/1
31. DEPARTMENT OF INDIAN AFFAIRS - : Statistics file No. 19/46/2
(DIVISION OF EDUCATION)
32. DEPARTMENT OF INDIAN AFFAIRS - : Circular No. 28 of 1972,
(DIVISION OF EDUCATION) File No. 19/15/6/2
33. DEPARTMENT OF INDIAN AFFAIRS - : Circular No. 39 of 1973,
(DIVISION OF EDUCATION) File No. 19/16/4
34. IBID
35. MULLER, J.D. : Providing for the top-level Learning
potential in a system of fully
Differentiated Primary Education,
Transvaal Education Department -
Education Bulletin Vol. 13, No. 3,
September 1968 pp. 146-147
36. BEHR, A.L. : A Textbook of Educational Methods,
Van Schaik, Pretoria, 1971 pp. 138-139

37. MULLER, J.D. : op.cit., pp. 146-147
38. DEPARTMENT OF INDIAN AFFAIRS - : Circular Minute AY of 1977,
(DIVISION OF EDUCATION) File No. 1/6/2/1
39. IBID
40. IBID
41. IBID
42. DEPARTMENT OF INDIAN AFFAIRS - : Statistics File No. 19/46/2
(DIVISION OF EDUCATION)
43. McCLELLAND, W. : Selection for Secondary Education,
University of London Press, London,
1949 pp. 163-173
44. McINTOSH, D.M. : Promotion for Primary to Secondary
Education, University of London Press,
London, 1949 pp. 135-140
45. DEPARTMENT OF INDIAN AFFAIRS - : Circular No. 28 of 1972,
(DIVISION OF EDUCATION) File No. 19/15/6/2
46. DEPARTMENT OF INDIAN AFFAIRS - : Circular No. 39 of 1973,
(DIVISION OF EDUCATION) File No. 19/16/4
47. DEPARTMENT OF INDIAN AFFAIRS - : Circular No. 31 of 1972,
(DIVISION OF EDUCATION) File No. 19/15/6/2
48. DEPARTMENT OF INDIAN AFFAIRS - : Handbook to Principals - 1978
(DIVISION OF EDUCATION)
49. DEPARTMENT OF INDIAN AFFAIRS - : Statistics File No. 19/46/2
(DIVISION OF EDUCATION)
50. DEPARTMENT OF INDIAN AFFAIRS - : Circular No. 39 of 1973,
(DIVISION OF EDUCATION) File No. 19/16/4
51. DEPARTMENT OF INDIAN AFFAIRS - : Circular No. 24 of 1977,
(DIVISION OF EDUCATION) File No. 19/15/6/2
52. DEPARTMENT OF INDIAN AFFAIRS - : Statistics File No. 19/46/2
(DIVISION OF EDUCATION)
53. DEPARTMENT OF INDIAN AFFAIRS - : Circular Minute AY of 1977,
(DIVISION OF EDUCATION) File No. 1/6/2/1
54. IBID

55. DEPARTMENT OF INDIAN AFFAIRS - : Circular No. 4 of 1977,
(DIVISION OF EDUCATION) File No. 9/34/1/16
56. JOINT MATRICULATION BOARD : Matriculation Examination Handbook,
1978
57. DEPARTMENT OF INDIAN AFFAIRS - : Circular No. 39 of 1978,
(DIVISION OF EDUCATION) File No. 9/34/1/17
58. DEPARTMENT OF INDIAN AFFAIRS - : Statistics File No. 19/46/2
(DIVISION OF EDUCATION)
59. DEPARTMENT OF INDIAN AFFAIRS - : Circular No. 24 of 1977,
(DIVISION OF EDUCATION) File No. 19/15/6/2
60. DEPARTMENT OF INDIAN AFFAIRS - : Statistics File No. 19/46/2
(DIVISION OF EDUCATION)
61. NATAL EDUCATION DEPARTMENT : File No. 39/1/10
62. DEPARTMENT OF INDIAN AFFAIRS - : File No. 19/20/6/2
63. IBID
64. DEPARTMENT OF INDIAN AFFAIRS - : File No. 19/46/2
(DIVISION OF EDUCATION)
65. IBID
66. IBID
67. IBID

CHAPTER 3

3. SOME FACTORS THAT INFLUENCE THE PLACEMENT OF PUPILS INTO THE DIFFERENT TYPES OF SECONDARY SCHOOL COURSES

3.1 FACTORS OUTSIDE THE CHILD THAT INFLUENCE PLACEMENT

3.1.1 The school curriculum

At the outset a distinction between curriculum, subject and syllabus needs to be made.

Behr (1977) sees the curriculum as having two meanings.

"In its narrow sense it means the course or subjects offered by a particular education institution. In the broader sense, curriculum means the sum total of learning experiences that a school gives its pupils in terms of classroom and extra curricular activities." (1) Hirst (1969), Kerr (1968) and Richmond (1971), by and large, support the view taken by Behr. (2)(3)(4) Curriculum may therefore be referred to as the organised learning experiences offered to the learner under the guidance of the school.

The school curriculum is organised into specific study areas called subjects e.g. Mathematics, English. The subjects that make up the school curriculum in Indian schools, in the various phases, have been mentioned in detail in the previous chapter.

Details of the content of a subject to be taught in any school year are set out in a document called the syllabus. From the syllabus the teacher plans the lessons that he intends teaching during the year. The syllabuses used in Indian schools since the implementation of Differentiated Education, in most subjects, are those that were drawn up by committees appointed by the Committee of Educational Heads. (5)

These syllabuses specifically drawn up for White schools are used in Indian schools with minor additions. The only syllabuses which are drawn up by committees appointed by the Division of Indian Education, for use in its schools, are those dealing with Indian languages. Examples of these syllabuses are: Arabic, Hindi, Tamil and Telegu.

The syllabuses used in Indian schools have not been assessed in the context of Indian Education to ascertain whether they are serving, as Behr puts it, "the optimum educational needs of the child".⁽⁶⁾ Behr (1977) states that, "The subject matter must be geared to help pupils develop and improve their emerging abilities."⁽⁷⁾

Mention has been made in Chapter 2 of some 40% of Indian pupils in standards 5, 6 and 7 who either fail or obtain practical passes. It would therefore seem that syllabuses designed for the White sector cannot be taken over for implementation into the Indian school system without adaptation.

It therefore becomes necessary to assess the syllabuses currently used in Indian schools. Since this research is primarily concerned with the placement of pupils into practical and academic courses, it is not possible within the context of this work to assess the syllabuses used in Indian Schools. This could be a topic for another research.

3.1.2 Educational aims and objectives

A distinction between aims and objectives is made.

Aims, in general, can be thought of as general declarations of intent which give shape and direction to education. Two categories of aims can be distinguished: general aims and specific aims. Aims which refer to the end products of education or to "the broad generalities which describe what the school is

trying to do" (8) are called general aims (also referred to as ultimate aims). The following are examples of general aims stated in the Junior Secondary English syllabus of the Department of Indian Affairs:

"to promote the pupil's intellectual, emotional and social development;
to extend his ability to observe, to discriminate and to order his thoughts coherently;
to help him to understand himself and others so that he may live more fully, happily and responsibly". (9)

Those aims which are stated in terms of a specific field of study and at a specific level in the education of the individual are called specific aims. Examples of specific aims stated in the Junior Secondary English syllabus are given below:-

"Spoken English: to improve the pupil's fluency and his ability to speak clearly, correctly, confidently and with courtesy.

Written English: to write clearly, accurately and reliably". (10)

It is clear that aims alone are insufficient to direct the day to day teaching and testing in education, and it is therefore necessary, in order to make aims more practically feasible, to describe in some detail and to specify the expected outcomes, or intended behaviours, in any particular field of study.

When aims are refined in this way to an even more specific level in terms of intended behaviour they are referred to as objectives. (11)(12)

In this regard Brubacher (1962) has suggested that "in spite of their prime importance, the ultimate aims of education mark out the teacher's task in only the most general outlines". (13) He further pointed out that in order to be effective in the classroom these aims must be broken down into "more immediate, specific or proximate objectives for the pupil and teacher to pursue". (14)

Two types of objectives are distinguished: specific (or behavioural) objectives and instructional objectives. Objectives which are independent of subject matter and are stated purely in terms of behaviour are called specific (or behavioural) objectives, e.g. ability to recall or apply knowledge. Those objectives which are stated in even more detail, in terms of both content and behaviour are called instructional objectives, e.g. ability to apply comprehension skills.

Unlike general aims which are remote, and specific aims which are intermediate (but still too general), objectives are immediate and clearly relevant to the classroom situation. ⁽¹⁵⁾ In the context of Indian education the distinction between aims and objectives has not been defined. Syllabuses have both the general and specific aims stated, but no mention of educational objectives is made. In the view of the writer the absence of clearly defined educational objectives makes the assessment of pupils difficult.

The introduction of differentiated education resulted in pupils being instructed and assessed at different levels. In the senior secondary phase pupils may take subjects on either the higher or standard grade. In the junior secondary phase, teachers are required to teach and examine on two levels, and pupils are promoted into two courses i.e. the practical and academic courses.

The objectives in a standard grade course are not the same as in a higher grade course, or as in the academic and practical course. For example in a standard grade course the emphasis is on skills, understanding and knowledge covering a given content with limited emphasis on manipulation i.e. the use of knowledge to solve problematic situations. The reverse, however, will apply in a higher grade course. It therefore becomes necessary that the syllabuses must spell out the objectives of a course clearly.

These aspects of differentiated education make teaching and assessing pupils even more difficult. It may, therefore, be stated that one of the possible reasons for the large number of pupils passing into the practical course in Indian schools may be due to the lack of clearly defined educational objectives. It is important that all syllabuses be set out in terms of educational objectives so that teachers are able to determine the correct levels in both their teaching and assessment of pupils.

3.1.3 Teacher implications in selection

Much of the efficiency in any educational network depends on the organisation of schools. The most serious problem faced in differentiated education is the provision of teachers who can teach and assess at the different ability ranges. The need also to integrate the successive phases of differentiated education makes additional demands on the teacher's skill. Teachers need to face the challenge of adjusting their teaching to the intellectual levels of the various pupils in their classes. The teacher must be able to teach a particular subject at different levels, the pupil is confronted with a wider range of subjects. Further there should be co-ordination and co-operation between primary and secondary school teachers.

An aspect of differentiated education which needs to be mentioned is the transition from class teaching to subject teaching. In Indian schools the first year of the junior secondary phase (standard 5) is usually provided at the primary school. Here by and large class teaching is done in the examination subjects. Subject teaching is confined to non-examination subjects and to knowledge subjects such as History and Geography. When pupils are transferred to the secondary school, they have to become accustomed to subject teaching instead of class teaching.

It was pointed out in the previous chapter that the greatest failure rate in Indian schools is in standard 6. The standard 6 school year is, in most instances, the first year that pupils spend in secondary schools. It would therefore seem that the transition from primary to secondary school is not an easy one for many pupils. To make such a transition from the primary to secondary schools much easier, it is necessary for the primary school teachers to have a knowledge of the secondary school curriculum, so that teachers are aware of what is expected of the secondary school pupils. It is also important that the secondary school teachers are aware of what goes on in the primary school, so that any new knowledge is meaningfully developed on experience gained by pupils in the primary school. The teachers part is all important: "the quality of teacher determines the quality of education". (16)

To illustrate the importance of the teacher in the performance of pupils, Kotzee and Booyens (1962) studied pupils' scores in the primary school examinations i.e. the standard 5 examination. On comparing the primary school examination scores with the expected scores relevant to pupils' intellectual abilities, they found the school examination scores were too high. (17) This led Kotzee and Booyens to conclude that the discrepancy between pupils' intellectual abilities and their achievement in school examinations in nearly all the cases, showed that pupils were instructed on a level incompatible with their mental abilities. In such cases they could either have done more work or they could have done more advanced work. (18) It is reasonable to assume that this situation has not improved with the introduction of Differentiated Education, pupils being placed in the practical course in Indian schools are in fact underachievers, achieving possibly at the instructional level concomitant with the teaching in their classroom.



The decision to place many pupils into the practical course at the end of standard 5, without their having had real exposure to subject teaching in the secondary school is a matter that needs consideration. The writer feels that subject teaching in standard 5 could prepare pupils for the type of education that they are to receive in secondary schools. Further any selection for academic or practical courses based on subject teaching would take into account the type of education given to pupils in the secondary schools. Presently class teaching is used as a basis to select pupils for the different types of secondary school education which basically involves subject teaching.

3.1.4 The effects of the school on selection

The reputation of a school is largely determined by the success of its pupils. Thus it is only natural that many teachers tend to further increase the strain on pupils by devoting all their efforts in the last year or two to cramming those pupils who have a chance of passing with facts and neglecting school subjects or activities which do not directly contribute to this end. Another harmful effect often attributed to the selection system by secondary school teachers is that the coaching received at the primary schools "unfits" the pupil for sounder methods of study, and deadens their initiative. Gibson (1954) found a higher incidence of nervous traits (nail-biting, enuresis, frequent tears) among coached than uncoached pupils. ⁽¹⁹⁾ The tendency exists among primary school teachers to train their pupils for the particular kind of tests or examinations which are used in selection. The curriculum comes to be based on the tests rather than the tests reflecting the curriculum. ⁽²⁰⁾ A further complaint from secondary school teachers is that many pupils of only average ability who have been successfully crammed find work far beyond them. Either they tag along at the bottom of the academic class or develop

emotional or delinquent tendencies. ⁽²¹⁾ Pidgeon (1970) states that there is growing evidence to support the contention that the achievement of pupils "are more immediately and more strongly affected by the school's attitudes towards them than anything else". ⁽²²⁾ Good schools can offset the effect of a poor home, but bad schools can have harmful effects, particularly on children of moderate ability. ⁽²³⁾ Himmelweit and Swift (1969), in a longitudinal study, found that the type of school attended was a better predictor of "the behaviour, outlook, values and attainment of pupils than either his ability or his social background." ⁽²⁴⁾

Many children that are placed in the practical course in Indian schools are disappointed and resentful. ⁽²⁵⁾ These children are dubbed failures at an impressionable age, with the result that any interest in further educational progress is inhibited. Boredom and rebelliousness are only too rife in some practical course classes. These can be attributed to the after effects of selection.

3.1.5 The influence of selection on socially disadvantaged children

According to Gulliford (1969) socio-economic factors influence not only attainment but also the development of abilities. ⁽²⁶⁾ Various kinds of social disadvantages, particularly unstable family circumstances and "marked deviations from acceptable standards of child care", ⁽²⁷⁾ affect the progress of many children. Clegg and Megson (1968) state that as many as ten to twelve percent of children may be considered as children in distress. Their poor response is due to the stressful circumstances in which they live. ⁽²⁸⁾ Both, cultural and social disadvantages prevent able children from the full utilization of their abilities. The children in this group need not only good teaching of basic educational skills, but also enriched opportunities for improving their abilities in language and thinking. Many have the school

to look to for some sense of security and happiness to compensate for their environmental disadvantages. Croft (1967) states that education needs to include an element of social work and schools need to work in liaison with various social agencies. (29)

Some children that attend Indian schools are socially disadvantaged, but the extent to which this influences their education is not known. (30) It is, indeed, difficult for the school alone to detect socially disadvantaged children. The view taken by Croft (1967) that schools should work in liaison with the various social agencies is supported by the writer.

In an investigation conducted by Dale (1965) and Griffith (1965) to determine the influence of the home in the deterioration of scholastic attainment, it was found that children who performed poorly came from skilled, semi-skilled and unskilled manual working classes. (31) Lexton (1961) concludes that "a low socio-economic level of living, has a marked impact on school achievement in a variety of ways". (32) It may therefore be stated that a multitude of factors may be responsible for the number of pupils passing into the practical course in Indian schools. Later in this dissertation the writer will (among other factors) consider the relationship between parental occupation and academic achievement.

3.1.6 Educational labelling and its influence on pupils

Forness (1975) states that evidence has shown that a child labelled mentally retarded may behave as he does in academic situations not necessarily because he is intellectually retarded, but because the label contributes to a teacher's expectation of his academic progress. (33) This does suggest that some pupils labelled as practical grade (dull normal) actually fulfil

the role of a dull normal only when certain social labels are imposed on them. Forness (1975) further states that research has failed to show conclusively that special class placement is any more beneficial for certain children than simply leaving them in a regular classroom in competition with normal peers. (34) This argument may also be used when children are referred to as dull normal. Cohen (1974) studied the effects of labelling in a British Secondary School. He found that children placed in lower ability streams developed a lower self concept of themselves and their academic ability. (35) Lacey (1970) and Hargreaves (1967) found that the organisational framework of schools through their reward structures led to the development of different pupil sub-cultures. (36)(37) The labels given to pupils with less academic abilities resulted in these pupils having a lower self-concept of themselves. In the experience of the writer it was found that pupils placed into the practical course reflected low self esteem. The teachers together with other pupils contributed to this feeling. Further these pupils formed their own sub-cultures in schools.

While the effect of a "no label" system may be advantageous to some children, it is by no means certain that either teachers or other children outside the system will treat "exceptional" children as a group any differently. The "no label" system does cause administrative and organisational problems. Teachers in such a system may not be specialists to deal with special learning problems. Further, teachers may not be competent enough to handle the various syllabuses and curricula for the diverse groups of pupils under their care.

3.2 FACTORS WITHIN THE CHILD THAT INFLUENCE PLACEMENT

3.2.1 Intelligence, aptitudes and grouping of pupils

Although there are many factors that have a bearing on the pupil's aptitude for learning, the most important, according to

Muller (1968),⁽³⁸⁾ Guilford (1963),⁽³⁹⁾ Behr (1971)⁽⁴⁰⁾ and Vernon (1960),⁽⁴¹⁾ is intellectual ability or I.Q.

Pupils differ in intellectual ability one from another. The distribution of intelligence in the population at large based on test results obtained with the New South African Group Test is given in table 3.1.⁽⁴²⁾

TABLE 3.1

DISTRIBUTION OF INTELLIGENCE BASED ON THE NEW SOUTH AFRICAN GROUP TEST⁽⁴³⁾

Ability Grouping	Percentage of Population	I.Q.
Sub-normal	± 2,3	69 and lower
Borderline	± 6,9	70 to 79
Dull-average	± 16,0	80 to 89
Average	± 49,6	90 to 109
Above average	± 16,0	110 to 119
Superior	± 6,9	120 to 129
Very superior	± 2,3	130 and above

Providing for pupils of different intellectual abilities in the ordinary classroom situation is no easy task. The teacher has to cater for the bright pupils as well as average. On the other hand the group of dull-average pupils will experience considerable difficulty in coping with the standard and rate of learning of the majority of their classmates. For these pupils special provision needs to be made. Effective group teaching could cater for the different ability groups in a classroom. Behr (1977) states that for purposes of instruction the teacher could well be advised to regard his class as composed of three groups, namely, (i) a group of dull-average pupils with I.Q. ranging from 80 to 89 and comprising

about one-sixth of the class; (ii) a group of average and slightly above average pupils with I.Q.'s from 90 to 119 and comprising about three-quarters of the class; (iii) a group of bright pupils with I.Q.'s above 120 and comprising about one-twelfth of the class. (44)

At the beginning of the year the teacher should find out the abilities of each pupil in his class so that he can adapt his teaching methods to the needs of each child. This is very important at the standard 5 level because pupil performance in the standard 5 school examination determines the type of course the pupil will follow in secondary schools. At the end of a school year a teacher should be able to distinguish between the dull-normal child and the rest of the class. If the percentage of pupils grouped as dull-normal is above 16%, the teacher has to evaluate his teaching methods, content areas covered, and measurement and assessment of pupils' work. There is a tendency (as shown in Chapter 2 some 37% of pupils in standards 6, 7 and 8 in Indian schools are in the practical course) that teachers tend to regard too many pupils as dull-normal and so direct them into the practical course. Simply grading too many children as dull-normal is not educationally sound; areas of weaknesses need to be detected and remedial measures applied.

The question now arises whether any grouping, segregation or selection of pupils is educationally desirable. The common experience of teachers is that groups become more manageable and easier to teach if they do not differ too widely in respect of their intellectual and emotional characteristics. (45)

Grouping by attainment tests was legalized in Britain by the 1944 Acts. (46) In South Africa, the National Education Policy Act (No. 39 of 1967(f)) which reads,

"education shall be provided in accordance with the ability aptitude of and interest shown by the pupil, and the needs of the country, and that appropriate guidance shall, with due regard thereto be furnished to pupils" (47)

gives education departments the authority to group pupils in "accordance with", their ability and aptitude.

Yet grouping and selection have created outcry from parents partly because differences in ability to some extent goes with differences in social class, and partly because of its implications for family prestige. The move currently is away from differentiation to integration (Warnock Report). (44)

According to Vernon (1960) children who are placed in a low stream, to suit their present level of ability, are likely to be taught at a slower pace, whereas the brighter streams, often under the better teachers, are encouraged to proceed more rapidly. Thus initial differences increase, and the duller children who happen to improve later fall too far behind the higher streams in attainments to be able to catch up. They lose the chance to show their true merits. (49) In Indian Education it has become almost an impossibility for pupils who have been placed in the practical course, to flow back into the academic course and to perform at the level of academic course pupils. (50)

In an experiment conducted by Vernon (1956), he found that children with below average ability performed better when left in ordinary classes with brighter children, than when they were separated from the brighter ones. Vernon concluded that the pressure of examinations and homework in the ordinary classrooms forced the below average pupils to learn more quickly. (51) Whether this is educationally sound is debatable.

3.2.2 Maturation and its influence on the education of pupils

Educationists (Behr (1971), Muller (1967), Burt (1966)) are in agreement that maturation has a tremendous influence on learning. (52)(53)(54) According to Piaget, the development of thinking passes through a number of consecutive stages, each of which is characterized by its own distinctive processes. The final stage of thought development is the formal operational stage and this begins at about the age of 11 - 12 year, i.e. in the years of transition from senior primary to junior secondary school. (55) Further Piaget states that it takes some children much longer to reach the formal operational stage of thinking.

It is possible that the large number of pupils falling into the practical course are pupils who have not as yet reached the formal operational stage of thought development - due to socio-economic factors. Piaget states that assimilation and accommodation in the first 3 years of life lay down schemata that are fundamental for later cognitive development, it may well be that the socially disadvantaged don't develop formal operational thinking at an early enough stage. (56) It would therefore seem more beneficial to these pupils if they were given an additional year to complete the primary school course. The practical course is definitely not intended for pupils who develop late.

3.2.3 The age of transfer to secondary school courses

In a school system in which there are different types of secondary school courses, the age of transfer is generally also the age of selection. In Indian schools the age of transfer from primary schools to secondary schools is generally 12 years. Children who are generally 12 years are in standard 5 at this

stage, and it is at the end of standard 5 that a decision is made as to the type of secondary school course the pupil has to follow. In 1963 the Scottish Council for Research in Education sponsored a research project to examine the question of the most appropriate age of transfer from primary to secondary schools. It was found that the transition from primary to secondary education should extend over the whole period from age 10 to 13. (57) Some children mature earlier than others. It was therefore concluded that "Prescribing age limits within this period for a change of school is justifiable for administrative reasons, not on psychological grounds". (58) In Indian Education transfer from primary to secondary school courses is not based on age, but on the performance of pupils in the standard 5 primary school examination. (59)

Another argument that has often been used against selecting pupils, for the different types of secondary school courses, at the age of 11+ is that the onset of puberty has an influence on scholastic performance. In the Scottish Council Research (1963) it was found that the onset of puberty does not produce marked changes in behaviour or thinking. Therefore, the actual influence of the onset of puberty on scholastic performance is negligible. (60)

In Indian Education no research has as yet been undertaken to determine the influence of the onset of puberty in the selection of pupils for the different types of secondary school courses.

3.3 THE PROBLEM OF FAILURE AND RELATED MATTERS

The problem of failure in school has been the focus of numerous researches, yet there is no conclusive understanding of the complexity of the problem. (61) Several studies, Van der Walt (1962), (62) Coombs (1967), (63) Finlayson (1973), (64) Cullen (1969) (65) show positive relationship between socio-economic background and academic

achievement. Children in Indian schools come from a wide spectrum of socio-economic status. The extremes range from those who may be classified as extremely wealthy down to the poverty stricken and economically depressed groups. (66)

In a survey conducted by the University of Natal (1967) it was found that 66,1% of the Indian families in Durban had incomes of less than R79 per month. (67) In another survey (University of Natal (1969)) it was found that approximately 50 - 60% of the householders in their sample had incomes below the cost of living minimum, and approximately 30 - 40% of the householders had incomes above the minimum. (68) The extent to which the number of pupils in the practical course in Indian schools could possibly come from below average socio-economic environments will be discussed later in Chapter 4.

In a comprehensive survey of the incidents of failure in Indian schools during the period 1966 - 1970, Van der Walt (1972) found that in primary schools, pupils failed at an average annual rate of 10,3% per standard. (69) It was further found that 20 out of every 100 standard 6 pupils reached standard 10 in the minimum period of 5 years, and of these 15 obtained a standard 10 certificate; for the period 1969 - 1973, the retention rate had risen to 29%, i.e. for every 100 pupils in standard 6, 29 reached standard 10 in the minimum prescribed period, though only 17 obtained a senior certificate or matriculation pass. (70) The table below reflects the failure per standard in Indian schools in 1977. (71)

TABLE 3.2

FAILURE PER STANDARD IN INDIAN SCHOOLS IN 1977

Std./Cl.	Total	No. Failed	% Failure
i	22860	1992	8,72
ii	21146	1618	7,65
I	20249	1315	6,49
II	20007	1125	5,62
III	20290	1910	9,41
IV	18707	1552	8,30
V	16320	655	4,01
VI	14826	602	4,06
VII	12750	1109	8,70
VIII	11856	1768	14,91
IX	6023	1304	21,65
X	4839	524	10,80

The table above reflects a drop in the failure rate when compared with the 1966-70 investigation conducted by Dr. N. van der Walt. (72)

The average failure rates for the period 1966 to 1970 is given in table 3.3. (73)

TABLE 3.3

AVERAGE FAILURE RATES IN INDIAN SCHOOLS FOR THE PERIOD 1966 TO 1970

Standards	5	6	7	8	9	10
Failure Rates	11,21	14,23	16,15	18,20	24,3	47,1

One possible reason for a drop in the failure rate in 1977 could be the introduction of the practical course in 1974. (74) Pupils who would have normally failed are now promoted into the practical course

in standards 6, 7 and 8. Another possible reason could be attributed to the improved inspection service rendered by the Departmental inspectors of education. ⁽⁷⁵⁾ The quality of education and the socio-economic conditions have a bearing on school failure. ⁽⁷⁶⁾ Since a large group of Indian children come from low socio economic environments, it is possible to assume that the scholastic performance of these children will be influenced by their environment. This will be discussed in Chapter 4.

3.4 THE UNDERACHIEVING CHILD

In Chapter 2 mention has been made of the number of children falling into the practical courses in Indian schools. It was stated that in 1977, some 30% of the total standard five school population in Indian schools fell into the practical course. In the same year about 38% of the standard 6, 43% of the standard 7 and some 32% of the standard 8 school population were in the practical course. ⁽⁷⁷⁾ Since the practical course is intended for dull-normal children, who should constitute \pm 16% of the school population, it becomes necessary to find an explanation for the abnormally high number of pupils falling into the practical course. One possible reason for the high percentage of pupils in the practical course is that a large number of pupils in this course may not be dull-normal children, but under-achievers. It therefore becomes necessary to look into the possible causes of underachievement. The underachiever is categorised by the teacher as lazy or lacking application or not working up to expectation. ⁽⁷⁸⁾

Success is said to occur when actual attainment exceeds predicted attainment, and underachievement when the actual attainment drops below the predicted level. In arriving at actual and predicted attainment, standardized language and mathematics test scores, mental age, examination results, class tests, and teachers estimates and impression should be carefully compared and considered. ⁽⁷⁹⁾

There is fairly general agreement among psychologists that individuals can be classified as either extroverts or introverts. The former reflects the degree to which one is sociable or outgoing; the latter the degree of ease with which one's anxiety is aroused. Behr (1974) states that there is a significant relationship between success at school and introversion, whereas extroversion is significantly related to school failure. Introverts tend to become conditioned more easily than extroverts to the academic moves which make for success at schools. ⁽⁸⁰⁾ It is possible to assume that the practical course has more extroverts than introverts.

Research in this area is needed. The writer from his own experience found that pupils in the practical course were generally extroverts.

Behr (1974) further mentions a third dimension of personality, viz that of dependence-independence. This dimension reflects the degree to which the pupil is concerned with pleasing the teacher and parents. If these persons value his performance he will tend to achieve better. ⁽⁸¹⁾ In the experience of the writer, it was found that pupils, in the practical course showed marked improvement in their work when what little they did was praised.

Two other aspects of personality need to be mentioned. These are immaturity and self-concept. Saranoff and Raphael (1955) associated immaturity with underachievement. ⁽⁸²⁾ Immaturity involves behaviour that is uncontrolled, uncritical, self-centred and irresponsible. ⁽⁸³⁾ An observation of practical course pupils some how leads one to conclude that the majority of them display immature behaviour patterns. According to Tuel and Wursten (1965) a negative self-concept appears to hinder academic performance, while in others a negative self-concept would seem to be the product of poor academic achievement. ⁽⁸⁴⁾ Children in the practical course usually have a very negative self-concept of themselves. They feel that the very fact that they are in the practical course reveals their lack of academic abilities.

According to Behr (1974) some underachievers tend to accept only the good in themselves. They are unwilling to risk being wrong, being disappointed or performing poorly. They expect to achieve at a high level with little effort. These individuals tend to put the blame for their failure on the inefficiency of the teaching and lack of fairness in the teachers. (85)

Behr (1974) mentions four points that need to be considered in reducing the number of underachievers in schools. First, there should be a positive, encouraging and hopeful attitude on the part of the teacher. "A disparaging teacher not only undermines the self-concept of the pupil, but also inhibits the release of the latter's intellectual powers and potential." Second there should be an authority structure within the school that permits and encourages individual development. Third, teaching methods that capitalize on the particular strength of individual pupils, are called for, "Fourth a comprehensive system of educational guidance, counselling and remedial services is sine qua non". (86)

These factors may play a vital role in reducing the number of underachievers, at the same time reducing the number of pupils that fall into the practical course in Indian schools.

3.5 THE IMPORTANCE OF INTELLIGENCE AND APTITUDE TESTS IN SELECTING PUPILS FOR SECONDARY SCHOOL COURSES

Burt (1950), Peel (1949) and Alexander (1947), are in agreement that one of the most essential features in the process of selection for secondary school courses should be the use of intelligence tests. (87)(88)(89) There are others, Blackburn (1945), Fleming (1947) who hold the contrary view. (90)(91) Blackburn has declared that it has been "all too readily assumed that intelligence tests are measuring innate intelligence and nothing else, whereas all that has been shown is, in fact that they measure the ability to answer intelligence test questions." (92) Fleming (1947) points out that recent researchers

have shown how the subsequent progress of many pupils may fail to conform with the predictions based on intelligence tests applied five or ten years earlier. Burt (1950) states that no psychologist has ever supposed that intelligence tests "furnish perfect measurements of innate ability, any more than a clock or watch gives a perfect measure of the lapse of time".⁽⁹³⁾ At a symposium on Selection for Secondary Schools held in Britain in 1950, the vast majority of psychologists agreed that at the age of 11+ innate general intelligence can be estimated with reasonable accuracy by means of standardized tests.⁽⁹⁴⁾ Behr (1977) and Muller (1968) also support the view that intelligence tests do reflect on the innate abilities of pupils.⁽⁹⁵⁾⁽⁹⁶⁾

The writer feels that intelligence tests must form part of the instruments used for selecting pupils for the different types of secondary school courses.

The question on which many psychologists differ widely is the degree of importance attached at measuring special aptitudes, particularly aptitudes that might decide the allocation of the child to the different types of secondary school courses. Alexander (1947) states that certain abilities can be measured at about 11+ while other abilities only emerge at 13+.⁽⁹⁷⁾ Peel (1949) on the other hand concludes that if abilities can be measured at 13+ they can equally be measured at 11+. He feels that the instrument of measurement may be at fault.⁽⁹⁸⁾ Bradford (1950) suggests that measureable differences (between success at verbal and practical tests respectively) may be expected among pupils of 11 years of age, if their mental age is at least 12 years.⁽⁹⁹⁾ Rodger (1950) warns us that "detecting special bents" is in most cases extremely difficult even at the age of fifteen and to attempt to do so at eleven is bound to give "the whole business an air of unreality".⁽¹⁰⁰⁾

The measurement of special abilities at the age of 11+ does present a problem, psychologists cannot agree whether special abilities can be measured reasonably at this stage. Nevertheless cognisance must

be taken of the existence of many different abilities within a group of children. (Guilford J.P. (1963)) (101) Although it is not always possible to alter the content of the curriculum to suit the individual needs of children, "methods of teaching should be adapted to the aptitudes, interests and mental limitations of the child". (102)

The writer is of the opinion that intelligence tests rather than aptitude tests would serve a more useful purpose in selecting pupils for the academic and practical courses in Indian schools. The selection would take into account general intelligence rather than specific abilities. At the present selection into the practical and academic courses is based solely on scholastic performance as assessed by teachers.

3.6 FACTORS TO BE TAKEN INTO CONSIDERATION WHEN PLACING PUPILS INTO THE DIFFERENT TYPES OF SECONDARY SCHOOL COURSES

Alexander (1947) states that the allocation of pupils for the different types of secondary school courses should be based on tests of the child's abilities, aptitudes, and attainments, together with assessments of "the more important character factors and in the light of his cumulative record in school, with reference to health factors; and sociological factors cannot be ignored". (103) Burt (1950) states that selection of pupils should be made, "not simply on intellectual grounds alone, such as would be supplied by a scholastic examination and by tests of general intelligence and special aptitudes, but on as wide and comprehensive a basis as is practicable". (104) Burt and Alexander agree that it is important to distinguish between the child's acquired attainments, as measured by examinations in English, Mathematics etc., and the child's innate abilities. They agree that the greatest weight should be attached to inborn capacities. (105)

Emmett (1947) conducted an experiment to evaluate the predictive validity of the primary school examination for selection of pupils

for the different types of secondary school courses. Emmett found that the best single predictor of future success was the intelligence test. The examination papers were least effective. (106)

Dempster (1948) supporting the view of Burt, Alexander and Emmett states that selection of pupils for the different types of secondary school courses cannot satisfactorily be carried out by a set of papers worked by candidates on "one fateful day" in their lives. As far as is possible, the full personality and environment of each child must be considered. (107)

In an investigation conducted by McClelland (1942), to find a system of assessment of ability and attainment that give the most reliable forecast of the type of post-primary course for which each pupil should be fitted, it was found: The results of intelligence tests were of considerable help in selection for secondary education. Group or individual intelligence tests should be applied to all primary school pupils at least a year before the selection stage. A second test should be applied in cases where the teacher has doubts about the validity of the I.Q., in these cases individual tests should be given. (108)

Teachers estimates alone should not be used for selection purposes. The school examination proved to be the best single measure for predicting success in secondary schools. (109)

McClelland states that intelligence tests, school examinations as well as teachers estimates used collectively can provide valid information for selecting pupils for secondary school education. Finally McClelland states that "no matter what system of selection is adopted, allowance must always be made and the educational system must be sufficiently flexible to allow for the unexpected development of individual children". (110)

In Indian Education the current policy is to apply the intelligence tests to pupils who are in standards 6 and 7. ⁽¹¹¹⁾ Pupils who are in standard 5 i.e. the year in which selection is commenced, have no I.Q. scores available. The writer is of the opinion that all pupils in standard five should be given an intelligence test. The test scores when available must be taken into account, together with other factors before a child is placed into either the practical or academic class. Currently all selection for practical and academic classes in Indian schools is based on the two internal school examinations. One is written in June and the other in November of the same year.

The writer takes the view that in selecting pupils for the academic and practical courses in Indian schools several factors need to be scrutinised. School examinations, intelligence tests, teachers estimates, environmental and psychological factors need to be considered collectively.

REFERENCE

1. BEHR, A.L. : A Textbook of Educational Methods, van Schaik, Pretoria, 1977 p. 25
2. HIRST, P.H. : "The logic of the curriculum", Journal of Curriculum Studies, Vol. 1, No. 2, May 1969 pp. 37-39
3. KERR, J.E. : Changing the Curriculum, University of London Press, London, 1968 pp. 13-17
4. RICHMOND, W.K. : The School Curriculum, Methuen and Co. London, 1971 pp. 174-192
5. BEHR, A.L. : New Perspectives in South African Education, Butterworths, Durban, 1978 pp. 71-84
6. BEHR, A.L. : A Textbook of Educational Methods, van Schaik, Pretoria, 1977 p. 27
7. IBID
8. WHEELER, D.K. : Curriculum Process, University of London Press, London, 1967 p. 27
9. DEPARTMENT OF INDIAN AFFAIRS (DIVISION OF EDUCATION) : Syllabus for English Higher Grade Standards 5, 6 and 7, 1973
10. DEPARTMENT OF INDIAN AFFAIRS (DIVISION OF EDUCATION) : Syllabus for English Higher (Practical Course) Standards 6, 7 and 8, 1973
11. WOOD, R. : "Objectives in the teaching of Mathematics", Educational Research, Vol. 10, No. 2, 1968 p. 83
12. TABA, H. : Curriculum Development, Theory and Practice, Harcourt, Brace and World Inc., New York, 1962 p. 196
13. BRUBACHER, J.S. : Modern Philosophies of Education, McGraw-Hill, New York, 1962 p. 118
14. IBID
15. MOODLEY, M. : The Construction and use of an evaluation instrument to measure attainment of objectives in Mathematics learning at senior secondary school level, M.Ed. Thesis, University of Durban-Westville, 1975 p. 11

16. NISBET, J.D. AND ENTWISTLE, N.J. : The Age of Transfer to Secondary Education, University of London Press, London, 1966 p. 89
17. KOTZEE, A.L. AND BOOYENS, M.J.G. : "Educational Tests - the basis for a sound educational programme in the primary school", Transvaal Education Department - Education Bulletin, Vol. 7, No. 2, June 1962 p. 97
18. IBID : p. 99
19. DEMPSTER, J.J. : "Symposium on the selection of pupils for different types of Secondary Schools" British Journal of Educational Psychology, Vol. 17, 1947 p. 126
20. CLEGG, A.B. : Some Problems of Administration in West Riding Grammar Schools, University of Leeds, No. 7, 1962 pp. 7-15
21. VERNON, P.E. : Secondary School Selection, Methuen and Co., London, 1960 p. 55
22. PIDGEON, D.A. : Expectation and Pupil performance, NFER Slough, England, 1970 p. 54
23. BEHR, A.L. : Meeting the needs of the under-achieving child in South Africa: An analysis of current resources and needs: Address delivered at the National Conference on the Under-achieving child - University of Durban-Westville, Durban, 1974 p. 6
24. HIMMELWEIT, H.T. AND SWIFT, B. : "A model for the understanding of school as a socializing agent", Trends and Issues in Developmental Psychology, Holt, Rinehart and Winston, New York, 1969 p. 43
25. DEPARTMENT OF INDIAN AFFAIRS (DIVISION OF EDUCATION) : Psychological Service File No. 19/34/6/3
26. GULLIFORD, R. : "Backwardness and Educational Failure", National Foundation for Educational Research in England and Wales, Exploring Education, London, 1969 pp. 15-16
27. BEHR, A.L. : op. cit., pp. 111-114
28. CLEGG, A.B. : op. cit., pp. 7-15

29. CROFT: cited by CROPLEY, A.J. : Creativity and Intelligence, The British Journal of Educational Psychology, Vol. 36, Part 3, November 1966 pp. 259-264
30. RAMPHAL, C. : A Study of Three Current Problems of Indian Education, Doctor of Philosophy Thesis, U.N. 1961 pp. 266-267
31. DALE, R.R. AND GRIFFITH, S. : Down Stream Failure in the Grammar School, Routledge and Kegan Paul, London, 1965 pp. 14-30
32. SEXTON, P. : Education and Income, Viking Books, New York, 1961 pp. 12-52
33. FORNESS, S.R. : "Implications of Recent Trends in Educational Labelling", The Education Digest, Vol. 40, No. 5, January 1975 pp. 15-17
34. IBID : p. 17
35. COHEN, L. : "Labelling and Alienation in a British Secondary School", Educational Review, Vol. 26, No. 2, January 1975 p. 43
36. IBID
37. IBID
38. MULLER, J.D. : "Providing for the top-level learning potential in a system of fully Differentiated Primary Education", Transvaal Education Department - Education Bulletin, Vol. 13, No. 3, September 1968 pp. 146-147
39. GUILFORD, J.P. AND HOEPFNER, R. : Report from Psychological Laboratory, University of Southern California, No. 30, 1963
40. BEHR, A.L. : A Textbook of Educational Methods, Van Schaik, Pretoria, 1971 pp. 137-139
41. VERNON, P.E. : op. cit., pp. 55-60
42. HUMAN SCIENCE RESEARCH COUNCIL : Catalogue of Tests, Pretoria, 1976 p. 10

43. IBID
44. BEHR, A.L. : op. cit., p. 138
45. VERNON, P.E. : op. cit., p. 40
46. IBID : p. 41
47. BEHR, A.L. AND : Education in South Africa, Van Schaik,
MACMILLAN, R.G. Pretoria, 1971 p. 19
48. WARNOCK REPORT : cited at conference on Special
Education at University of Durban-
Westville: Fiat Lux, Vol. 13, No. 8,
October 1978 pp. 6-7
49. VERNON, P.E. : op. cit., pp. 42-43
50. DEPARTMENT OF INDIAN AFFAIRS : Statistic File 19/46/2
(DIVISION OF EDUCATION)
51. VERNON, P.E. : The Measurement of Abilities (Rev.Ed.)
University of London Press, London,
1958 p. 88
52. BEHR, A.L. : Psychology and the School, Butterworth,
Durban, 1975 pp. 18-21
53. MULLER, J.D. : "A re-appraisal of certain principles
guiding the Mental development and
Motivation of Children in the Light
of the Research Work of Jean Piaget",
Transvaal Education Department
Education Bulletin, Vol. 7, No. 2,
June 1967 pp. 76-87
54. BURT, C. : The Causes and Treatment of Back=
wardness, University of London Press,
England, 1966 pp. 19-34
55. BEHR, A.L. : op. cit., pp. 18-21
56. IBID : pp. 19-21
57. NISBET, J.D. AND : op. cit., pp. 89-90
ENTWISTLE, N.J.
58. IBID : p. 89
59. DEPARTMENT OF INDIAN AFFAIRS : Circular Minute AY of 1977,
(DIVISION OF EDUCATION) File No. 1/6/2/1

60. NISBET, J.D. AND ENTWISTLE, N.J. : op. cit., pp. 12-13
61. BANKS, OLIVER AND FINLAYSON, D. : Success and Failure in the Secondary School - An Interdisciplinary Approach to School Advancement, Methuen and Co., London, 1973 p. 8
62. VAN DER WALT, N. : Die Vraagstuk van druiping op skool - 'n geskiedkundige-vergelykende studie, PHD. Thesis, University of South Africa, 1962 p. 186
63. COOMBS, R.H. AND DAVIS, V. : "Socio-Psychological Adjustment in Collegiate scholastic success", The Journal of Educational Research, Vol. 61, No. 4, December 1967 pp. 186-187
64. FINLAYSON, D. : "Towards a Socio-Psychological view of School Achievement", The British Journal of Educational Studies, Vol. 21, No. 3, October 1973
65. CULLEN, KATHLEEN : School and Family-Social Factors in Educational Attainment, Gill and MacMillan, Dublin, 1969 p. 204
66. NAGURAN, C.A. : A study of failure in school with special reference to Indian Secondary Education in Natal - M.Ed. Thesis, University of Durban-Westville, 1978 p. 42
67. DEPARTMENT OF ECONOMICS, UNIVERSITY OF NATAL : A Survey of Indian Housing in Durban, 1967
68. DEPARTMENT OF ECONOMICS, UNIVERSITY OF NATAL : "The Indian Domestic Budget" Additional Report No. 6 of Natal Regional Survey - Kertlands, Durban, 1969 p. 73
69. VAN DER WALT, N. : "Failure at School (part 1)" Fiat Lux, Vol. 7, No. 9, November 1972 pp. 18-21
70. IBID
71. DEPARTMENT OF INDIAN AFFAIRS : File No. 19/43/2
(DIVISION OF EDUCATION)
72. VAN DER WALT, N. : op. cit., pp. 18-21
73. DEPARTMENT OF INDIAN AFFAIRS : File No. 19/43/2
(DIVISION OF EDUCATION)

74. DEPARTMENT OF INDIAN AFFAIRS : Circular No. 28 of 1972, File No. 19/15/6/2
(DIVISION OF EDUCATION)
75. DEPARTMENT OF INDIAN AFFAIRS : File No. 19/15/6/2
(DIVISION OF EDUCATION)
76. VAN DER WALT, N. : op. cit., pp. 18-21
77. DEPARTMENT OF INDIAN AFFAIRS : File No. 19/43/2
(DIVISION OF EDUCATION)
78. BEHR, A.L. : op. cit., p.2
79. EYSENCK, H.S. : Facts and Fiction in Psychology,
Penguin Books, Harmondworth, 1965
pp. 52-94
80. BEHR, A.L. : op. cit., p.3
81. IBID : p.4
82. SARANOFF, I. AND RAPHAEL, T. : "Five failing college students",
American Journal of Orthopsychiatry,
Vol. 25, 1955 pp. 343-372
83. BEHR, A.L. : op. cit., p. 3
84. TUEL, J.K. AND WURSTEN, R. : "The influence of intra-personal
variables and academic achievement",
Journal of Educational Research,
Vol. 16, No. 2, 1965 pp. 58-64
85. BEHR, A.L. : op. cit., p. 4
86. IBID : pp. 9-10
87. BURT, C. : "Symposium on the Selection of Pupils
for Different Types of Secondary Schools",
British Journal of Educational Psychology,
Vol. 20, February 1950 p.1
88. PEEL, E.A. : "Symposium on Selection of Pupils
for different types of Secondary
Schools", British Journal of
Educational Psychology, Vol. XIX,
1949 pp. 1-15
89. ALEXANDER, W.P. : "Testing for the Secondary Technical
School", British Journal of
Educational Psychology, Vol. 17,
1947 pp. 123-130

90. BLACKBURN, J. : Psychology and the Social Pattern, 1945 pp. 8-68
91. FLEMING, C.M. : Adolescence, 1947 pp. 108-111
92. BLACKBURN, J. : op. cit., p. 68
93. BURT, C. : op. cit., p. 2
94. ALEXANDER, W.P. : op. cit., pp. 123-130
95. BEHR, A.L. : A Textbook of Educational Methods, van Schaik, Pretoria, 1971 pp. 137-139
96. MULLER, J.D. : "Providing for the top-level Learning potential in a system of fully Differentiated Primary Education", Transvaal Education Department - Education Bulletin, Vol. 13, No. 3, September 1968 pp. 146-147
97. ALEXANDER, W.P. : op. cit., p. 129
98. PEEL, E.A. : op. cit., p. 14
99. BURT, C. : op. cit., p.4
100. IBID : p. 9
101. GUILFORD, J.P. AND HOEPEFNER, R. : Report from Psychological Laboratory, University of Southern California, No. 30, 1963
102. BURT, C. : op. cit., p. 10
103. ALEXANDER, W.P. : op. cit., pp. 123-130
104. BURT, C. : op. cit., p.1
105. ALEXANDER, W.P. : op. cit., p. 128
106. EMMETT, W.G. : "Secondary Modern and Grammer School Performance predicted by tests given in Primary Schools", British Journal of Educational Psychology, Vol. 23-24, 1953-1954 pp. 91-99
107. DEMPSTER, J.J.B. : op. cit., p. 121
108. McCLELLAND, W. : Selection for Secondary Education, University of London Press, London, 1949 p. 4

109. McCLELLAND, W. : op. cit., p. 216
110. McINTOSH, D.M. : Promotion from Primary to Secondary Education, University of London Press, London, 1949 pp. 137-140
111. DEPARTMENT OF INDIAN AFFAIRS : File No. 19/20/6/2
(DIVISION OF EDUCATION)

CHAPTER 44. A STUDY OF THE PLACEMENT OF PUPILS INTO PRACTICAL AND ACADEMIC CLASSES IN FIFTEEN INDIAN SECONDARY SCHOOLS IN THE GREATER DURBAN AREA4.1 THE NATURE OF THE PRESENT STUDY

The present study is essentially a descriptive research. Good (1963), Borg (1967) and Behr (1973) state that descriptive research precedes other types of research because "existing facts and prevailing conditions" need to be known before progress can be made in solving certain problems. (1)(2)(3) While descriptive research is primarily concerned with conditions as they are, it nevertheless involves much more than mere fact finding. "It must seek to discover cause and effect relationships, and attempt to give interpretations as well." (4) In this chapter the researcher aims to discover cause and effect relationships related to the placement of pupils into academic and practical classes in Indian schools. An attempt will be made to give interpretations to the findings as well.

4.2 PROCEDURE IN THE PRESENT STUDY4.2.1 The purpose of the present study

The purpose of the present study is to discover factors that influence the placement of pupils into practical and academic classes in Indian schools. Mention has been made in Chapter 2 of the large number of pupils who are placed into the practical course because of their poor performance in two major subjects i.e. English and Mathematics in internal school examinations.

In the internal school examination each school is responsible for setting question papers in the various subjects for its school. The question papers are set on syllabuses prescribed by the Division of Indian Education. Although syllabuses are prescribed, no set procedure in respect of assessment are

given. Further mention has already been made of the lack of clearly defined objectives in the syllabuses used in Indian Education. For these reasons, the content tested and the type of questions set in the internal school examinations in Indian Schools vary from school to school. The internal school examinations in standards 5, 6 and 7 are used for selecting pupils for the practical and academic courses.

To find possible reasons for the abnormally high percentage of pupils (some 37%) being placed into the practical course, the Division of Indian Education decided in 1977 to set an external examination for pupils in standards 5, 6 and 7 in the two major subjects viz: English and Mathematics. The purpose of the external examination was to measure the difference in performance of academic and practical course pupils writing the same papers in the subjects mentioned.

The question papers used in this investigation are those set by the Division of Indian Education. ⁽⁵⁾ Details concerning the procedure adopted by the Division of Education in setting the external examination papers in English and Mathematics will be discussed later.

The influence of age, parental occupation and intelligence on the types of pupils being placed into practical and academic courses will also be assessed. The writer in his capacity as an employee of the Department of Indian Affairs, Division of Education, was involved in this project. He was responsible for the research design and the follow-up studies.

4.2.2 The procedure adopted by the Division of Education in constructing tests in English and Mathematics

For purposes of assessing the scholastic attainment of pupils in English and Mathematics in standards 5, 6 and 7 academic course, the Division of Education set papers for each of the three standards in the subjects mentioned. The procedure laid down by the Joint Matriculation Board in setting examination question papers for the senior certificate examination was adopted. (6)(7) The Joint Matriculation Board recommends the panel system of setting question papers. (8)

To set question papers in English and Mathematics for standards 5, 6 and 7 academic course, the Division of Education appointed in June 1977 two panels, each consisting of three members. (9) One panel was responsible for setting papers in English and the other in Mathematics.

Three papers were set in each of the two subjects, one for each standard viz. standard 5, 6 and 7. Detailed marking memoranda for each paper set were also prepared by members of the panel.

The panel of English examiners consisted of 3 experienced teachers who had taught English for over a period of 10 years. They had also taught standards 5, 6, 7 and other standards under the new system of differentiated education. The new system of differentiated education was introduced in Indian schools in 1973. (10) Members of the panel also had experience in setting English question papers for internal school examinations over a number of years. For the past two years, two of the 3 members on the panel have set English question papers for the Senior Certificate Examination of the Department of Indian Affairs. The other member has been a sub-examiner for the Senior Certificate Examination for the past two years. (Examiners are persons appointed by the Division of Indian Education to set question papers for the Senior Certificate

Examination. Sub-examiners are those appointed to mark the answers of candidates for the examination.) (11)

The Mathematics question papers were also set by three experienced teachers whose teaching experience in Mathematics ranged from 7 to 15 years. They had taught standards 5, 6, 7 and other standards under the new system of differentiated education. Members of the panel also had experience in setting Mathematics question papers for internal school examinations. One member of this panel had experience of setting question papers for the Senior Certificate Examination of the Department of Indian Affairs. The other two members were sub-examiners for Mathematics in the Senior Certificate Examination for the past two years.

In setting the question papers for standards 5, 6 and 7 the members of the panels were guided by the internal examination papers in English and Mathematics set by a number of schools. These papers were based on the syllabuses for standards 5, 6 and 7 (academic course). The syllabuses are given in Appendix I.

Once the papers were set by the two panels they were submitted for moderation. The English papers were moderated by a subject expert, presently holding the post of Inspector of Education. The Mathematics papers were moderated by a Senior Assistant Education Planner, also a subject expert. The moderators suggested some minor changes to the content of the papers. These changes were made by the panel of examiners.

The final draft question papers, 6 in all, were submitted by the examiners to the Division of Indian Education in November 1977.

In the absence of any standardised scholastic attainment tests in English and Mathematics for standards 5, 6 and 7 for Indians the researcher obtained the permission of the Director of Indian Education to use the external examination question papers set for standards 5, 6 and 7 in these subjects.

The use of external examination question papers for purposes of research is not a new feature. In Britain research conducted by Williams and Boreham (1972), Backhouse and Willmott (1974) and Deafe (1976) have used question papers set by either subject experts or examining bodies, e.g. Schools Council Examinations, for purposes of assessing curricula and examinations. (12)(13)(14) In South Africa the Transvaal Education Department's project school experiment made use of the attainment of pupils in the external examination (Senior Certificate Examination) to assess the predictive validity of school assessment made by teachers. (15) In another experiment conducted by the Natal Education Department known as the year mark experiment pupil attainment in the external examination (Senior Certificate Examination) was used as a yard stick to assess the validity and reliability of teacher's assessment. (16) In both these experiments it was concluded that while teachers predictive assessment in some schools can be reliable in many other schools teachers assessment was unreliable.

The Department of Indian Affairs conducted an experiment in 1977 to assess the relative standards in the higher grade and standard grade papers written by pupils in the Senior Certificate Examination. (17) Here again use was made of external examination papers.

It is interesting to note that many researchers on examination and assessment have concluded that standardised scholastic

attainment tests and external examinations are more reliable for purposes of selection for secondary school courses than the internal school examination. Some of these will be discussed below.

In 1971 the Schools Council in Britain appointed a committee to "be responsible for the planning and co-ordinating of feasibility and development studies covering the whole field of secondary school examinations". One of the major factors that prompted the establishing of this committee was the differing standards of assessment in the various secondary schools. The committee recommended that some form of "a common system of external assessment" conducted by an examining body within each Local Education Authority would be more reliable than school assessments. ⁽¹⁸⁾ In another investigation by Tawney (1976) on "curriculum evaluation", it was concluded that "the evaluation of school curricula" can best be attained by pupil performance in scholastic achievement tests. ⁽¹⁹⁾ (Curriculum in this sense means the sum total of learning experiences given to the pupils by the school. This includes classroom as well as extra-curricular activities). Further, Ingram (1968) states that the examination "is much the most accurate method of testing students knowledge of the subject", ⁽²⁰⁾ The examination papers for standards 5, 6 and 7 in English and Mathematics referred to above are external examinations in terms of the procedure set out by the Division of Indian Education. ⁽²¹⁾

In an extensive research conducted by McClelland (1949) on the selection of pupils for secondary school courses in Britain, McClelland concluded that use should be made of standardised intelligence tests and scholastic attainment tests similar to external examinations for purposes of selecting pupils for the different types of secondary school courses. ⁽²²⁾

From the foregoing it is concluded that scholastic attainment tests and external examinations as measures of knowledge gained by pupils in a subject are more reliable instruments of measurement than the internal school examination.

In this investigation the researcher used the external examination question papers in Mathematics and English set by the Division of Indian Education to determine whether there are any significant differences in the performance of pupils graded into academic and practical courses at the end of the standards 5, 6 and 7 school years. The pupils are graded on the basis of their performance in the internal school examinations. As mentioned earlier (chapter 2) Mathematics and English are the two major subjects taken by all pupils and the majority of pupils perform poorly in these subjects.

4.2.3 The pilot study

A pilot study was conducted in January 1978. In this study the external examination papers in English and Mathematics for standards 5, 6 and 7 academic course, were applied to a mixed group of academic and practical course pupils.

It must be pointed out that although the pupils used in this investigation were in standards 6, 7 and 8 in January/February 1978, the external examination papers tested work completed by these pupils in standards 5, 6 and 7 respectively.

The standard 6 pupils wrote the question papers set for standard 5, the standard 7 pupils wrote the question papers set for standard 6, and the standard 8 pupils wrote the question papers set for standard 7. This procedure was adopted because the pupils used in this investigation had just started the new school year in standards 6, 7 and 8.

The schools at this stage were merely revising work covered by pupils in the previous year.

The pilot investigation was conducted in two schools viz, Risecliff High and Glenover High. Both these schools are in Chatsworth, and according to an investigation conducted by the University of Durban-Westville (1972), ⁽²³⁾ the people of Chatsworth cover a wide spectrum of the socio-economic stratum of the Indian Community.

The following procedure was adopted in selecting the sample. The principals of the schools were requested to hand in the class registers of all academic and practical standards 6, 7 and 8 pupils. Every pupil on the register was given a number. Each standard and course was treated separately. The researcher used the table of random numbers and selected approximately $\frac{1}{3}$ of the pupils in each standard and course.

The distribution of the sample according to school and course is given below.

TABLE 4.1

DISTRIBUTION OF SAMPLE USED IN THE PILOT INVESTIGATION

Schools	Academic Standards			Practical Standards		
	6	7	8	6	7	8
	No.	No.	No.	No.	No.	No.
Risecliff	23	26	27	28	27	24
Glenover	27	25	26	23	25	22
Total	50	51	53	51	52	46

The academic and practical course pupils in the same standard wrote common papers. The English papers were written on the 23 January and the Mathematics papers on 24 January 1978. The papers were of 1½ hours duration. The procedure adopted in the distribution of question papers, marking and data collection was the same as for the final investigation. These aspects will be explained later in this chapter.

To determine the difference in performance between academic and practical course pupils writing the same papers, the means, standard deviations and critical ratios of difference between the means were calculated. These statistical techniques will be explained in detail under the sub-heading "data processing and statistical analysis" later in this chapter.

Table 4.2 gives the mean and standard deviation obtained by academic and practical course pupils in standards 6, 7 and 8.

TABLE 4.2

MEANS AND STANDARD DEVIATIONS OBTAINED IN THE EXTERNAL EXAMINATIONS IN ENGLISH AND MATHEMATICS IN THE PILOT INVESTIGATION

		Mathematics			English		
		NO	\bar{M}	SD	NO	\bar{M}	SD
Std. 6	Academic	50	44,2	19,9	50	59,3	12,3
	Practical	51	30,1	7,9	51	46,2	9,7
Std. 7	Academic	51	43,9	15,1	51	56,3	10,7
	Practical	52	30,7	12,1	52	47,4	9,1
Std. 8	Academic	53	43,3	13,1	53	45,2	7,4
	Practical	46	29,8	9,07	46	41,7	6,8

From the table it is observed that there is greater difference in the performance of academic and practical course pupils in Mathematics than in English in all three standards. The spread of scores (SD) among practical course pupils is less than that of academic course pupils in both subjects. Is there a significant difference between the means of the two groups writing the same papers? In order to ascertain this the critical ratio (CR) is calculated. The obtained critical ratios (CR) and significant levels (p) is given in the table below.

TABLE 4.3

CRITICAL RATIOS AND SIGNIFICANCE LEVELS FOR THE DIFFERENCE OF THE MEAN PERFORMANCE OF ACADEMIC AND PRACTICAL COURSE PUPILS IN ENGLISH AND MATHEMATICS

		CR	P
Std. 6	Mathematics	4,62	< 0,01
	English	5,87	" < 0,01
Std. 7	Mathematics	4,85	< 0,01
	English	4,55	< 0,01
Std. 8	Mathematics	6,02	< 0,01
	English	2,43	< 0,05

From the table it is concluded that there is a significant difference between the means obtained by the practical and academic groups in tests in English and Mathematics. The significance is generally at the 0,01 level of significance.

The pilot investigation indicated that a comparison between academic and practical course pupils writing the same papers can be made by using the external examination papers in English and Mathematics set by the Division of Indian Education. The pilot investigation further indicated that a few alternative answers to items in the question papers were not included in the marking memoranda supplied to teachers. These answers were then included in the memoranda. The investigation also indicated that there were wide variations in the marking of the essay type question. In the final investigation the essay answers were marked independently by two different teachers. Only in cases where there were wide variations in the marks awarded in the first and second marking, were these scripts assessed by a moderator. The different methods of marking the essay type question have been discussed in Chapter 1.

Apart from the above mentioned changes, the question papers and the procedure adopted in obtaining data from schools in the pilot test were the ones used in the final investigation. The final external examination papers, following the amendments that were incorporated as a result of the pilot study, are included as Appendix II of this dissertation.

4.3 THE MAIN INVESTIGATION

4.3.1 Population

The pupils in the 15 schools who were in standards 5, 6 and 7 academic course in 1977 and who were promoted into either the practical or academic course, depending on their performance in the internal school examination, formed the total population in this investigation. Since it was not possible to conduct this investigation after the end of year school examination of 1977, the question papers referred to above

were administered to a sample of pupils in February 1978. The pupils in 1978 were placed into standards 6, 7 and 8 either the practical or academic course depending on the type of pass they had obtained in the school based examination of 1977.

4.3.2 Schools in the sample

At the beginning of 1978 there were 24 State Secondary Schools in the Durban and District area. There were 16 schools in the Southern Durban area (Chatsworth - Merebank - Clairwood complex), 4 schools in the Western area of Durban, 3 schools in the Central Durban area and one in the Northern area of Durban. ⁽²⁴⁾ Since it was necessary to examine the relationship between academic performance and parental occupation, age and intelligence among pupils being placed into practical and academic courses, it was decided that a large representative sample of schools should be selected in order to produce statistically dependable results.

Therefore 15 secondary schools were selected to represent a cross-section of the various urban, sub-urban and rural communities of the Greater Durban Area. Table 4.4 gives the names of schools, the number of pupils chosen from the academic and practical course and the standards in which the pupils were in 1978.

TABLE 4.4

DISTRIBUTION OF PUPILS IN THE SAMPLE AMONG SCHOOLS

Name of School	Std. 6			Std. 7			Std. 8		
	Ac	Pr	T	Ac	Pr	T	Ac	Pr	T
1. Apollo	73	35	108	-	-	-	34	34	68
2. Shallcross	33	41	74	33	37	70	30	37	67
3. Protea	70	41	111	-	-	-	36	-	36
4. Glenover	35	38	73	39	43	82	32	34	66
5. Meadowlands	72	33	105	41	31	72	33	36	69
6. Southlands	37	37	74	72	38	110	35	-	35
7. Montarena	33	42	75	38	36	74	32	33	65
8. P.R. Pather	73	40	113	33	37	70	33	-	33
9. Asoka	38	35	73	41	30	71	31	32	63
10. Witteklip	-	72	72	31	35	66	29	39	68
11. Isipingo	41	35	76	35	31	66	38	33	71
12. Risecliff	-	-	-	32	42	74	36	30	66
13. Clare Hills	-	-	-	36	41	77	33	34	67
14. Mountview	-	36	36	34	33	67	31	38	69
15. Westcliff	-	-	-	33	43	76	30	35	65
TOTAL	505	485	990	498	477	975	493	415	908

TOTAL SAMPLE = 2873

All the schools chosen were secondary schools with pupil enrolments of 600 + pupils. Of the 15 schools in the sample 10 were chosen from the Chatsworth Area. As mentioned earlier a survey by the University of Durban-Westville (1972) revealed that the population of Chatsworth was drawn from all over the Durban metropolitan area, and thus represents a wide range of socio-economic levels.

Two schools, Isipingo and Mountview draw pupils from below average to above average socio-economic homes. The pupils at Isipingo High school come from the poor shack dwellings of Malagasie as well as the affluent areas of Isipingo Beach and Isipingo Heights. Mountview High has pupils from the rural sugar cane plantations. These pupils live in wood and iron buildings with no electricity. They obtain water from communal water points. Mountview High also has pupils from above average homes coming from the Everest Heights Township.

The other two schools Shallcross and P.R. Pather High have pupils who come from below average and average homes. The houses in these areas were constructed by the Durban City Corporation. Most people living in these houses are tenants of the Durban City Corporation.

Since the location of schools used in this study indicates a good coverage of the Indian areas in the Greater Durban Area, the sample schools were considered to be representative of the population under study.

4.3.3 Pupils in the sample

Since it would have been a costly and time consuming effort to select the total standards 6, 7 and 8 school populations in this investigation, it was decided to select about 50% of the pupils in each of the standards in these schools. Some schools, however, did not have any pupils in a particular standard or course. However, since conclusions will be drawn on the overall sample of over 2800, the fact that some schools did not have some pupils in a particular course or standard will (in the view of the writer) not invalidate the findings. A table of random numbers was used to make the selection from each school. More or less a thousand pupils comprising

about 500 academic and about 500 practical course pupils, were chosen in each standard. Table 4.4 indicates the actual number of pupils chosen in each standard or course.

The sample of pupils can be divided into three distinct groups: viz. a group of standard 6 pupils who on the basis of their performance in the standard 5 school examination was promoted into either the academic or practical standard 6 course; the second group comprised standard 7 pupils who on the basis of their performance in the standard 6 academic course school examination was promoted into standard 7 either the academic or practical course and the third group was made up of standard 8 pupils who on their performance in the school examination in standard 7 academic course was promoted into standard 8 either the academic or practical course.

As mentioned earlier, that although the pupils used in this investigation were in standard 6, 7 and 8 in 1978, the external examination question papers written by them covered work which they had completed in the previous year.

A breakdown of the pupils constituting the sample is given below. The distribution of pupils according to sex was determined by the enrolment in the two courses.

TABLE 4.5

DISTRIBUTION OF PUPILS IN RESPECT OF COURSES IN THE SAMPLE

Course	S T A N D A R D S					
	6		7		8	
	Boys	Girls	Boys	Girls	Boys	Girls
Academic	239	266	257	241	273	220
Practical	266	219	266	211	218	197
Total	505	485	523	452	491	417

The total sample used in this investigation was 2873 pupils. The total population was 12380. The sample therefore constitutes 23,21% of the total population. Borg (1967) and Best (1959) state that the larger the sample used in a research, the smaller will be the standard error and the greater the likelihood of obtaining significant results. (25)(26) The large random sample ensures to some extent that the uncontrolled variables will themselves be operating randomly for the different groups being studied and therefore will not have a systematic effect upon the results. (27) Since the random sample used in this investigation constitutes some 23% of the total population, it can therefore be regarded as representative of the standards 6, 7 and 8 academic and practical course pupils in Indian schools.

4.3.4 Method of data collection

The instrument used for data collection in this investigation are external examinations in English and Mathematics. Examinations are generally used for promotion or retardation of pupils at the end of a school year. The external examinations in English and Mathematics used in this investigation is not intended for this purpose. It is therefore felt for purposes of this investigation the external examinations in English and Mathematics will be referred to as tests. The definition of a test is given in paragraph 1.2 of Chapter 1. Details concerning the construction, use and interpretation of tests is also discussed in that chapter.

Teachers were required to supply the names of pupils tested in their schools, the sex, age as at 1 January 1978, IQ scores, the number of times pupils had failed, the fathers' occupation, as well as the scores obtained by pupils in the Mathematics

and English Tests. The information had to be supplied on a form designed by the researcher. Appendix III.

4.3.5 Distribution of test papers, marking memoranda and data form

The Test papers, marking memoranda and the data forms were taken personally by the writer to the fifteen schools. The writer explained the procedure to be followed by principals in the administering of the Tests and the compilation of the required information. In each school the following procedure was to be adopted:

Principals were requested to submit a list of the names of pupils in standards 6, 7 and 8 academic and practical course in their school. From the list a sample of pupils required to write the Tests in Mathematics and English were selected on a random basis. The researcher made use of a table of random numbers. (28)

Principals were informed that the sample of standard 6 practical and academic course pupils were to write the same standard 5 English and Mathematics papers. The sample of standard 7 academic and practical, and standard 8 academic and practical course pupils were to write, respectively, the standard 6 and 7 English and Mathematics papers.

The question papers were each of 1½ hours duration. The English papers were to be written on the 28th of February and the Mathematics on the 29th of February 1978. Stationery required for the tests were to be supplied by the school. The papers had to be written under examination conditions. The examination conditions are prescribed by the Department of Indian Affairs in Circular No. 49 of 1975. (29)

Once the papers were written the principal had to arrange with his staff to get them marked. The following procedure had to be adopted in marking the papers.

Marking had to be done strictly according to the marking memoranda supplied. A team of teachers in each school marked the papers. A teacher was requested to mark a single section so that uniformity in marking could be maintained. In English the essay question had to be marked twice by two different teachers. This was carried out by all schools and when there were great variations in the marking of the essay by the two teachers, the moderator decided on the final mark. The moderator in each school was the senior subject teacher.

The procedure employed in marking the scripts differed from that employed in the Senior Certificate Examination in the following respect.

In the Senior Certificate Examination the marking is centralised, all scripts are marked by a panel of sub-examiners appointed by the Director of Indian Education. In this investigation the marking was done by teams of subject teachers appointed by the principal of each school. It is interesting to note that for the Senior Certificate Examinations of the Transvaal Education Department and the Natal Education Department no central marking committee is employed. Marking is done at a number of centres created within each province. (30) (3)

This system is employed to complete the marking within a short space of time so that the results for the examination could be posted as soon as possible to candidates. Further the project school experiment in the Transvaal places sufficient importance on teachers to mark the scripts of pupils within the school. The Joint Matriculation Board recognises the internal standard 10 school examination for purposes of matriculation exemption in the project schools.

The only external examination written by pupils in South African schools is the Senior Certificate Examination. Therefore the major part of marking in the structure of our educational system is done by teachers within the schools.

The writer, therefore, is of the opinion that marking of scripts done by teams of teachers according to detailed marking memoranda in this investigation will not invalidate the findings. Nevertheless after the scripts were marked they were moderated by senior subject teachers from within the school.

Once the scripts were marked and moderated they were given to the class teacher who then completed the data collection form mentioned earlier. (Appendix III)

Principals were requested to submit to the Director of Indian Education, the scripts, data collection forms and marking memoranda by the 20th of March 1978.

Mention must be made of the tremendous co-operation and assistance rendered by principals and teachers in this investigation. This co-operation was partly due to the fact that the number of pupils being placed into practical classes is of concern to them as well.

All scripts, data collection forms and marking memoranda were collected by the writer from the Department of Indian Affairs, Division of Education.

As a final check on the marking the English scripts were handed to the panel of three English teachers who had set the Test papers. The Mathematics papers were likewise handed to the Mathematics panel. The two panels had to scrutinise a certain number of scripts (about 20%) to check on the consistency of marking. The panels reported that the marking generally was consistent and accurate. The English panel, however, made a few minor changes in the marks allocated by a school in the essay type question. The panel felt that the marking of the essay type question at this school was far too strict.

The researcher then checked the marks recorded in the data sheets with that on the scripts. The data was now considered ready for processing by computer.

4.3.6 Data processing and statistical analysis of results

4.3.6.1 Data processing

The large sample necessitated the processing of data by computer. The researcher discussed the whole matter of data processing with the ICL computer firm. An experienced programmer was able to write out a COBOL programme (Appendix IV) on the data supplied to him. The researcher also informed him of the type of information he required. The data was converted to numerical codes before being transferred on to data processing sheets. An experienced punch card operator punched the coded data from the data sheets to ICL punch cards. The data for each pupil was punched on a separate card. Each card, after being punched was verified by an automatic verifier.

The computer programme did not include the working of Chi-square and correlation coefficients used in this study. These were done manually by the use of an electronic calculator.

4.3.6.2 Methods of statistically analysing the results

The purpose of the present study, as mentioned earlier, is to find the relationship between the performance of academic and practical course pupils in tests in Mathematics and English. Pupils of both the courses in a standard wrote the same papers. A further aim of the study is to find out if there are any causal relationship between the type of

pupil who follows the academic course and the one that follows the practical course. In order to test the significance of the effect of certain variables on the placement of pupils into practical and academic classes the Chi-squared statistical method is used. Borg (1967), Downie and Heath (1965) state that the X^2 technique is used as a test of significance when the data are expressed as discrete frequencies. (32)(33)

The X^2 statistic is known as a nonparametric or a distribution free statistic. It is a very useful test of significance because no assumptions are necessary about the shape of the parameter distribution.

The X^2 statistic is a method of determining whether the differences between the theoretical and the observed frequencies in any number of categories can reasonably be attributed to chance variations in sampling. (34)

The question arises as to whether the differences between the observed and theoretical frequencies are significant. In this context, the null hypothesis is that no differences exist between the observed and theoretical frequencies. If the observed frequencies depart significantly from the theoretical frequencies, this constitutes evidence for the rejection of the theoretical frequencies. (35)

An example of the calculation of the theoretical or expected frequencies and Chi-squared is shown below.

We wish to test the hypothesis that performance in Mathematics of a group of academic course pupils is independent of pupils I.Q. The calculation is set out in table 4.6. The procedure followed is as set out in Downie and Heath (1970).. (36)

TABLE 4.6

CALCULATION OF X^2 IN A TEST OF INDEPENDENCE BETWEEN I.Q. SCORES AND SCORES IN MATHEMATICS

	RANGE OF I.Q. SCORES						TOTAL
	70-79	80-89	90-109	110-119	120-129	130+	
Pass Maths	3(a)	49(b)	81(c)	45(d)	19(e)	5(f)	202
Fail Maths	3(g)	35(h)	17(i)	5(j)	1(k)	0(l)	61
	6	84	98	50	20	5	263

$$\text{Chi-squared } (X^2) = \sum \frac{(A-E)^2}{E}$$

where A = actual frequencies

E = expected or theoretical frequencies.

An example showing details of how the expected or theoretical frequency is calculated is given in Appendix V.

	A	E	A-E	(A-E) ²	$\frac{(A-E)^2}{E}$
a	3	4,6	- 1,6	2,56	0,55
b	49	64,5	-15,5	240,25	3,72
c	81	75,2	5,8	33,64	0,44
d	45	38,4	6,6	43,56	1,13
e	19	15,3	3,7	13,69	0,89
f	5	3,8	1,2	1,44	0,37
g	3	1,3	1,7	2,89	2,22
h	35	19,4	15,6	243,36	12,50
i	17	22,7	- 5,7	32,49	1,43
j	5	11,5	- 6,5	42,25	3,67
k	1	4,6	- 3,6	12,96	2,81
l	0	1,1	- 1,1	1,21	1,10
				$X^2 =$	<u>30,83</u>

$$\begin{aligned} \text{The df} &= (\text{possible results} - 1) (\text{no. of I.Q. intervals} - 1) \\ &= (2-1) (6-1) = 5 \\ \text{df} &= 5 \quad p < 0,01 \end{aligned}$$

At the 0,01 level of significance, the null hypothesis that performance in Mathematics of a group of academic course pupils is independent of pupils I.Q., is rejected. In other words pupils' performance in Mathematics is influenced by I.Q.

The relationship between the Mathematics and English scores of the same group of pupils is also calculated in the context of this work. This relationship is referred to as the correlation. Numerically the relationship, called the coefficient of correlation (r), has a value that falls between the limits of + 1,0 (a perfect positive relationship) and - 1,0 (a perfect negative relationship).⁽³⁷⁾ The Pearson's product moment correlation (r) is used in this work. The formula is given below.⁽³⁸⁾

$$r = \frac{N \sum xy - (\sum x)(\sum y)}{\sqrt{[N \sum x^2 - (\sum x)^2][N \sum y^2 - (\sum y)^2]}}$$

An example of calculating the Pearson's r correlation is given below. The following are marks obtained by 10 pupils in English and Mathematics respectively.

Pupils	1	2	3	4	5	6	7	8	9	10
English marks	33	46	38	39	59	36	54	41	33	51
Maths marks	45	64	43	41	39	42	59	56	44	67

Let the marks for English be designated x and for Mathematics y . To facilitate the calculation, a table is drawn up.

TABLE 4.7

COMPUTING PEARSON'S PRODUCT MOMENT CORRELATION FOR SCORES
IN ENGLISH AND MATHEMATICS

x	y	x ²	y ²	xy
36	45	1296	2025	1620
46	64	2116	4096	2944
38	43	1444	1849	1634
39	41	1521	1681	1599
59	39	3481	1521	2301
36	42	1296	1764	1512
54	59	2916	3481	3186
41	56	1681	3136	2296
33	44	1089	1936	1452
51	67	2601	4489	3417

$$\Sigma x=433 \quad \Sigma y=500 \quad \Sigma x^2=19441 \quad \Sigma y^2=25978 \quad \Sigma xy=21961$$

$$r = \frac{10 \times 21061 - 433 \times 500}{\sqrt{\{10 \times 19441 - (433)^2\} \{10 \times 25978 - (500)^2\}}}$$

$$r = 0,37$$

The correlation coefficient for 10 candidates is 0,37. The value of the correlation coefficient required for significance at the 0,05 and 0,01 levels for 10 candidates is read off from a table. ⁽³⁹⁾ In the case of the example $p > 0,05$. The correlation is therefore not significant. There is no significant relationship between the scores obtained by the same group of pupils in tests in Mathematics and English.

Apart from the chi-squared and correlation statistics other statistics used are: mean, standard deviation,

SE mean, and critical ratio. These will be now explained.

To get a good picture of the distribution of scores, we need to determine its central tendency as well as its dispersion. (40)
 The mean, used in this investigation, measures the central tendency and the dispersion is measured by the standard deviation. In the following example the mean and standard deviation are calculated. The table below gives the scores obtained by a group of academic and practical course (standard 8) pupils in Mathematics. x will represent the scores obtained by the academic group and y the scores obtained by the practical group.

TABLE 4.8

MATHEMATICS SCORES OBTAINED BY STANDARD 8 ACADEMIC AND PRACTICAL COURSE PUPILS IN THE SAME TEST

x	D	D^2	y	D	D^2
56	12,3	151,29	25	1,9	3,61
40	- 3,7	13,69	24	2,9	8,41
53	9,3	86,49	20	6,9	47,61
45	1,3	1,69	19	7,9	62,41
43	- 0,7	0,49	33	6,1	37,21
40	- 3,7	13,69	46	19,1	364,81
40	- 3,7	13,69	26	0,9	0,81
33	-10,7	114,49	14	12,9	166,41
46	2,3	5,29	40	13,1	171,61
41	- 2,7	7,29	22	4,9	24,01
$\Sigma x=437$	$\Sigma D^2 = 394,41$		$\Sigma y=269$	$\Sigma D^2 = 886,9$	
mean	$= \frac{437}{10}$		mean	$= \frac{269}{10}$	
	$= 43,7$			$= 26,9$	

$$SD = \sqrt{\frac{D^2}{N}}$$

$$SD_x = 6,28$$

$$SD_y = 9,42$$

In the above example the obtained mean and standard deviation for the academic course pupils are 43,7 and 6,28 respectively. For the practical course pupils the mean is 26,9 and the standard deviation is 9,42. Is there a significant difference between the two means? To test the significance of the difference between the two means the critical ratio is used. (The Critical ratio (CR) is a statistical technique used for testing the significance level of the difference between means involving large samples).

$$CR = \frac{M_1 - M_2}{\sqrt{(SE \text{ mean}_1)^2 + (SE \text{ mean}_2)^2}}$$

$$SE \text{ mean} = \frac{SD}{N-1}$$

$$SE \text{ mean}_1 = 2,09$$

$$SE \text{ mean}_2 = 3,14$$

$$CR = \sqrt{\frac{16,8}{14,22}}$$

$$= 4,46$$

$$p < 0,01$$

Since the CR value is greater than 2,58 significance is beyond the 0,01 level. In other words, such a difference would occur less than once in one hundred times by chance.

Apart from the statistics discussed, other statistics will be used less frequently. These will be explained when they arise.

4.3.7 The results of the present study

4.3.7.1 The Relationship between the performance of academic and practical course pupils in tests administered in English and Mathematics.

For the purpose of this research pupil attainment of 40% and above is considered a pass in the English and Mathematics tests. Mention has been made of the pass requirements in the various standards in Indian Education in Chapter 2. The pass requirement in the formal school examination for English and Mathematics in standards 6, 7 and 8 (academic course) is 40%.

Table 4.9 reflects the number and percentage of pupils that passed or failed the tests in English and Mathematics written by them in February 1978.

TABLE 4.2

NUMBER AND PERCENTAGE OF PUPILS THAT PASSED OR FAILED TESTS IN ENGLISH AND
MATHEMATICS IN EACH STANDARD UNDER STUDY

STANDARDS :		6				7				8			
COURSE :		ACADEMIC		PRACTICAL		ACADEMIC		PRACTICAL		ACADEMIC		PRACTICAL	
SEX :		MALE	FEMALE	MALE	FEMALE	MALE	FEMALE	MALE	FEMALE	MALE	FEMALE	MALE	FEMALE
English	No. Pass	227	253	223	200	241	235	241	197	228	201	170	152
	% Pass	94,9	95,1	83,8	91,3	93,7	97,1	90,6	93,4	83,5	91,4	78,0	77,1
	No. Fail	12	13	43	19	16	7	25	14	45	19	48	45
	% Fail	5,1	4,9	16,2	8,7	6,3	2,9	9,4	6,6	16,5	8,6	22,0	22,9
	TOTAL	239	266	266	219	257	242	266	211	273	220	218	197
Maths	No. Pass	137	126	40	7	180	114	68	16	206	148	64	42
	% Pass	57,3	47,4	15,0	3,2	70,0	47,1	25,5	7,6	75,5	67,3	29,4	21,3
	No. Fail	102	140	226	212	77	128	198	195	67	72	154	155
	% Fail	42,7	52,6	85,0	96,8	30,0	52,9	74,5	92,4	24,5	32,7	70,6	78,7
	TOTAL	239	266	266	219	257	242	266	211	273	220	218	197

From the table it is concluded that the difference in passes or failures in English between the academic and practical course pupils is slight. The situation, however, is different for Mathematics. More practical course pupils than academic course pupils fail Mathematics.

To determine whether there is any significant difference between the performance of academic and practical course pupils in the tests in English and Mathematics, the chi-squared statistic is calculated. Table 4.10 contains the chi-square and significance levels for performance of academic and practical course pupils in tests in English and Mathematics, according to sex and standards.

TABLE 4.10

CHI-SQUARE (X^2) AND SIGNIFICANCE LEVELS (p) FOR PERFORMANCE (PASS/FAIL) OF ACADEMIC AND PRACTICAL COURSE PUPILS IN TESTS IN MATHEMATICS AND ENGLISH ($df = 1$)

	S T A N D A R D S											
	6				7				8			
	X^2		p		X^2		p		X^2		p	
	MALE	FEMALE	MALE	FEMALE	MALE	FEMALE	MALE	FEMALE	MALE	FEMALE	MALE	FEMALE
Mathematics	* 98,4	118,0	< 0,01	< 0,01	104,0	85,5	< 0,01	< 0,01	104,0	88,7	< 0,01	< 0,01
English	16,1	2,8	< 0,01	> 0,05	1,8	3,56	> 0,05	> 0,05	2,40	16,2	> 0,05	< 0,01

* Example of X^2 calculation i.r.o. Std. 6 male performance in Mathematics:

Standard 6 - Males

	Pass	Fail	Total
Practical	40	226	266
Academic	137	102	239
Total	177	328	505

$$X^2 = \frac{505 (4080 - 30962)^2}{266 \times 239 \times 177 \times 328}$$

$$= 98,36 \text{ for } 1df$$

$$p < 0,01$$

The following conclusions are drawn: In Mathematics the difference in performance (pass/fail) between the academic and practical course pupils in standards 6, 7 and 8 is significant at the 0,01 level for both girls and boys. Pupils in the academic course performed in all cases better than pupils in the practical course. The percentage failure for Mathematics in the practical course was above 70% in all standards. In the academic course the percentage failure ranged from 24 to about 50%. It is interesting to note that in Mathematics the boys in each of the course and standard performed better than the girls. (Significance is at 0,01 level.)

The position in English is different. Generally there is no significant difference in the performance of academic and practical course pupils in standards 6,7 and 8 in English ($p > 0,05$). The only significant difference are between the males of standard 6 and the females of standard 8. In these cases the difference is significant at the 0,01 level of significance, further the academic course pupils generally performed better than the practical course pupils. The percentage failure in the practical course is as follows: Standard 6: 12,5% Standard 7: 8% and Standard 8: 22,5%. In the academic course it is as follows: Standard 6: 5% Standard 7: 4,6% and Standard 8: 12,5%. Apart from the standard 8 practical course where the performance in English is almost the same for boys and girls, the girls in all other instances generally performed better than the boys.

An overall scrutiny of the performance of pupils in English reveals that no clear cut distinction between the academic type and the practical type of pupil can be found. It is therefore felt that the scores obtained in English by pupils cannot be reliably used to determine the type of course a

pupil should pursue in secondary schools.

Pupil performance in Mathematics reveals that there is a distinct difference in the type of pupil that is placed into the academic and practical course. Further there is also a distinct difference in the performance of males and females in Mathematics ($p < 0,01$).

Is there a significant difference between the means obtained by the practical and academic groups who wrote the same paper? To determine the significance between the means the critical ratio was computed. The critical ratio (CR) and the significance levels p are given in the table below.

TABLE 4.11

CRITICAL RATIOS AND SIGNIFICANCE LEVELS FOR MEAN PERFORMANCE OF ACADEMIC AND PRACTICAL COURSE PUPILS IN TESTS IN ENGLISH AND MATHEMATICS (Boys and Girls combined)

STANDARD AND SUBJECT		CR	p
Standard 6	Mathematics	10,10	< 0,01
	English	7,25	< 0,01
Standard 7	Mathematics	8,04	< 0,01
	English	7,81	< 0,01
Standard 8	Mathematics	8,85	< 0,01
	English	3,89	< 0,01

From the table it is concluded that there is a significant difference between the means obtained by the practical and academic groups in tests in English and Mathematics. In all the tests the means obtained by the practical group in the sample were generally much lower than the means obtained

by the academic group. The difference in the means in English between the two groups for each standard is as follows:

Standard 6: 14%, Standard 7: 15,4% and Standard 8: 3,7%.

For Mathematics the difference is as follows: Standard 6: 20%, Standard 7: 14,3% and in Standard 8: 13,1%.

The difference between the means obtained in English and Mathematics ($p < 0,01$) leads one to conclude that in each case there is a distinct difference between the two groups. A different picture, however, emerges if the combined performance in Mathematics and English is considered for placement of pupils into practical and academic classes. If a pass in both subjects is considered a pre-requisite for placement into the academic course, then a number of pupils in the sample understudy would be considered to have been wrongly placed. The table below indicates the percentage and number of pupils in each course in the sample that would be considered to be wrongly placed.

TABLE 4.12

PERCENTAGE AND NUMBER OF PUPILS WHO ARE WRONGLY PLACED IN ACADEMIC AND PRACTICAL COURSES
 IN THE SAMPLE (BASED ON THE PERFORMANCE OF PUPILS IN TESTS IN ENGLISH AND MATHEMATICS COMBINED)

STANDARDS :	6				7				8			
	Academic course pupils who ought to have been placed into the Practical Course		Practical course pupils who ought to have been placed into the Academic Course		Academic course pupils who ought to have been placed into the Practical Course		Practical course pupils who ought to have been placed into the Academic Course		Academic course pupils who ought to have been placed into the Practical Course		Practical course pupils who ought to have been placed into the Academic Course	
	MALE	FEMALE	MALE	FEMALE	MALE	FEMALE	MALE	FEMALE	MALE	FEMALE	MALE	FEMALE
Number :	8	11	24	3	5	5	62	13	18	11	52	38
% of sample:	3,3	4,1	10,1	6,8	1,9	2,1	23,3	6,1	6,6	5,0	23,9	19,3

Is there a significant difference between pupils in the academic and practical courses who passed both i.e. English and Mathematics in each standard and those that failed both? The obtained X^2 and p for 1df are given in the table below.

TABLE 4.13

DIFFERENCE BETWEEN PUPILS IN THE ACADEMIC AND PRACTICAL COURSES WHO PASS BOTH I.E. ENGLISH AND MATHEMATICS.

STANDARD :	6	7	8
X^2 :	* 155,0	140,0	108,0
p :	<0,01	<0,01	<0,01
df :	1	1	1

*Example of X^2 calculation i.r.o. Standard 6 pupils is given below.

	Pass both	Fail both	
Practical course pupils	8,5	91,5	100
Academic course pupils	96,3	3,7	100
	104,8	95,2	200

$$X^2 = \frac{200 \times (8,5 \times 3,7 - 96,3 \times 91,5)^2}{104,8 \times 95,2 \times 100 \times 100}$$

$$= 155,0$$

$$p < 0,01 \text{ for 1df}$$

The difference between those that passed both i.e. English and Mathematics and those that failed both in the academic and practical courses in each of the standards is significant at the 0,01 level.

An analyses of the data in table 4.12 shows:

Some 7,7% of academic course pupils in the sample should, according to their performance in tests in English and Mathematics be placed into the practical course. On the other hand the situation in respect of pupils in the practical

course is disturbing. Some 29,8% of the sample of practical course pupils ought to have been placed into the academic course. This indicates that factors other than performance in English and Mathematics contribute to some 8% of academic course pupils and about 30% of practical course pupils being wrongly placed in the course they follow in secondary schools. Since English and Mathematics constitute the major subjects written by pupils in a school examination (refer Chapter 2), performance in these subjects reflect on the reliability of the school examination as a whole. It is therefore felt that the school examination alone should not be used for purposes of selecting pupils for academic and practical courses. Other factors which ought to be considered will be discussed in the next Chapter.

Some other findings of less importance to this work have also emerged. These are deduced from the graphs, reflecting the percentage pass in Mathematics and English in the 3 standards in both courses, on pages 152 and 153 . From the graphs it is noticed that the performance of females in English is generally better than that of the males in the same course. The performance of practical course females in English is lower than that of the performance of academic course males. In Mathematics it is found that the males in any one course perform better than the females. There is a wide variation between the performance of academic and practical course pupils in Mathematics.

PASSES IN THE MATHEMATICS TEST IN STANDARDS 6, 7 AND 8
PRACTICAL AND ACADEMIC COURSES ACCORDING TO SEX

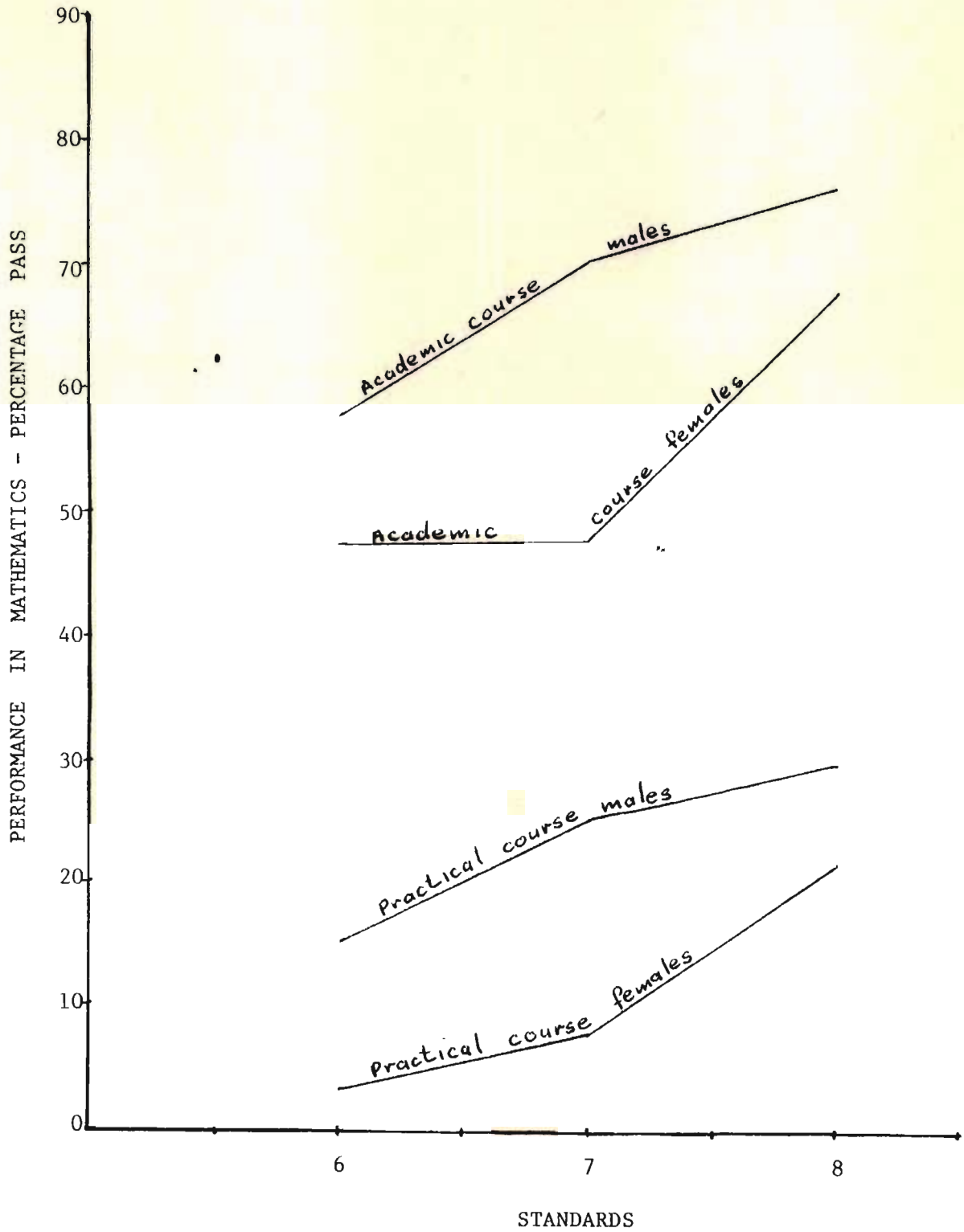

PASSES IN THE ENGLISH TEST IN STANDARDS 6, 7 AND 8 PRACTICAL AND ACADEMIC COURSES ACCORDING TO SEX

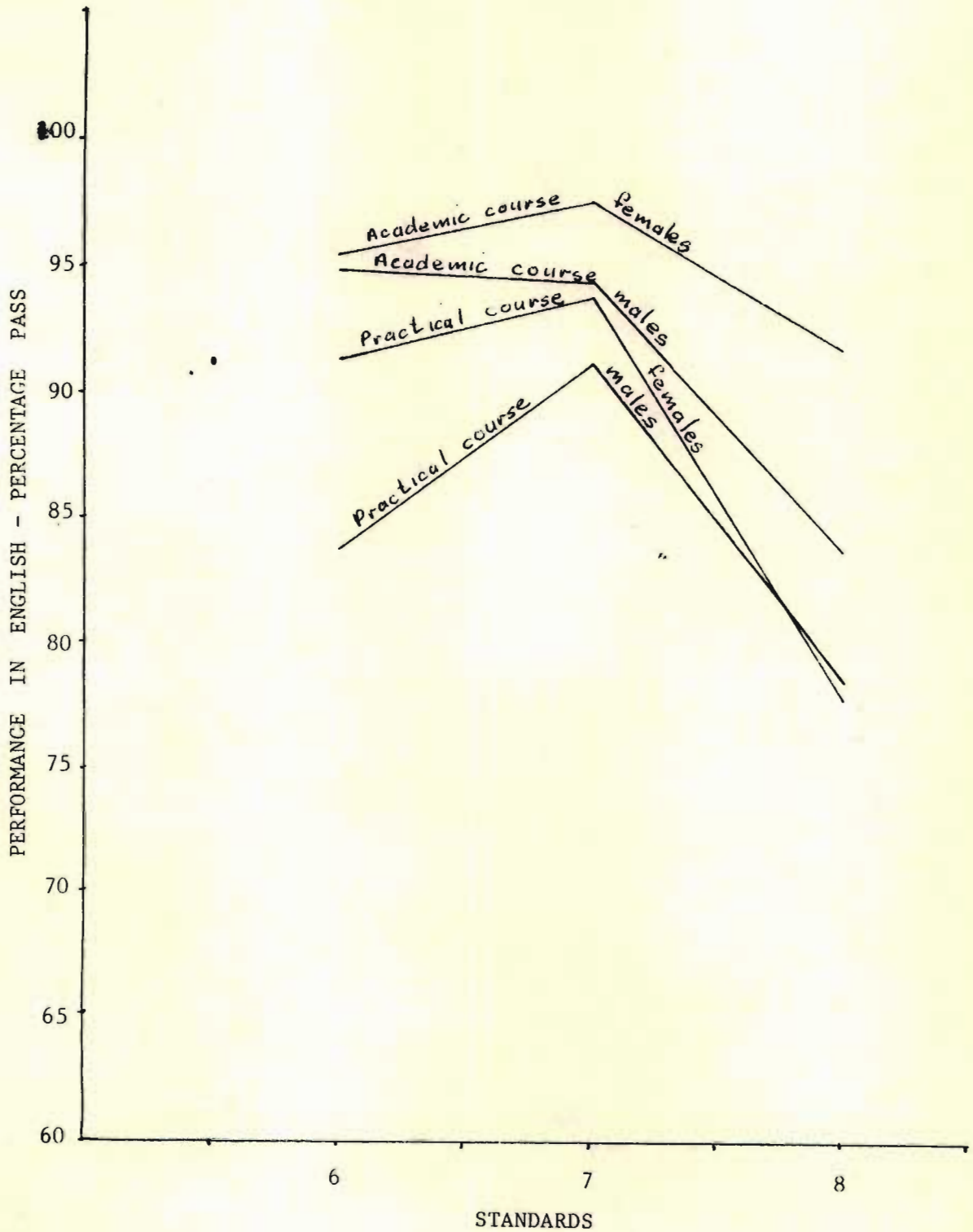

4.3.7.2 The Relationship between the scores obtained by the same pupils in the sample in tests in English and Mathematics

The contention that pupils that perform well in one subject generally perform as well in other subjects in the curriculum is supported by Strobel and Dudek (1974), Donlon (1974) and Erlick and Ogilvie (1975). (41)(42)(43) If this is so then pupils performing well in Mathematics in this investigation should do likewise in English. To determine the relationship between Mathematics and English scores obtained by the same pupils in the sample the Pearson's Product Moment Correlation is calculated. The correlation is computed separately for each course and standard. Details concerning the calculation of the correlation have been discussed at the beginning of this Chapter. The correlation coefficients and the significance levels are given in table 4.14.

TABLE 4.14

CORRELATION COEFFICIENTS AND THE SIGNIFICANCE LEVELS BETWEEN ENGLISH AND MATHEMATICS SCORES FOR A SAMPLE OF PRACTICAL AND ACADEMIC COURSE PUPILS

STANDARD :	6			7			8		
	N	r	p	N	r	p	N	r	p
Academic :	505	0,25	<0,01	499	0,37	<0,01	493	0,35	<0,01
Practical:	485	-0,10	>0,05	477	0,05	>0,05	415	0,07	>0,05

The correlation between the Mathematics and English scores obtained by the academic course pupils is significant at the 0,01 level of significance. This indicates that there is a "definite but slight" **positive** relationship between the performance of academic course pupils in tests in English and Mathematics.

This means that in general the pupils who do well in one subject also do well in the other subject. This applies to the academic course pupils only.

The correlation coefficients in respect of the performance of the practical course pupils in the same tests reveal a different picture. Here the correlation is not significant ($p > 0,05$). The scores obtained by the practical course pupils in English and Mathematics reveal an "indifferent almost negligible" relationship. ⁽⁴⁴⁾ It may be concluded that there is no consistency in performance in English and Mathematics among pupils placed into the practical course. The pupils being placed into the practical course are those who generally perform poorly in one or the other subject used in this investigation.

From the foregoing it may be stated that pupils being placed into the academic course are those that perform well in most subjects in the school curriculum; the situation in respect of practical course pupils is different. These pupils are generally weak in one or more subjects. The poor performance in some subjects could be due to several factors, such as poor teaching, emotional and psychological factors, poor environment, lack of aptitude and ability in a subject and poor motivation to learn. However, a discussion of these factors falls outside the scope of this dissertation.

4.3.7.3 The Age Factor and its influence on the placement of pupils into practical and academic courses

The fact that intellectual performance, as measured by tests of ability or scholastic achievement, is subject to variations according to age and season of birth has been noted by many research workers. Writers such as Pintner and Forlano (1933), Fitt (1941) and Jones (1964) produced evidence, from relatively large samples of children tested, to show that

generally age and season of birth have an influence on scholastic performance. (45)(46)(47) In this investigation the researcher uses the ages of pupils. The relationship between age and pupils being placed into practical and academic classes is examined.

4.3.7.3.1 The Relationship between age of pupils and the course followed in Indian Schools. The distribution of pupils in the sample according to age categories, standard and course is given in table 4.15.

TABLE 4.15

DISTRIBUTION OF PUPILS IN THE SAMPLE ACCORDING TO AGE CATEGORIES, STANDARD AND COURSE IN PERCENTAGES

AGE	STANDARD 6		STANDARD 7		STANDARD 8	
	ACADEMIC	PRACTICAL	ACADEMIC	PRACTICAL	ACADEMIC	PRACTICAL
12	28,1	11,5	-	-	-	-
13	51,9	32,3	25,7	17,6	-	-
14	14,1	36,5	57,0	51,0	19,7	26,5
15	4,3	14,0	14,1	22,2	53,8	54,0
16	1,6	4,1	3,2	7,1	21,3	16,4
17	-	1,6	-	1,7	5,2	2,4
18	-	-	-	0,4	-	0,7

From the table it is noticed that a large proportion of the pupils in standard 6 academic course fall into the age categories of 12 and 13 years. (The ages used have been rounded to the nearest year.) In the practical course of the same standard the majority of pupils fall into the age categories of 13 and 14 years. On considering the mean ages of the two groups it is noticed that the mean age for the standard 6 academic course is 13 years and for

the practical course it is 14 years. This suggests that the pupils in the practical course are generally a year older than pupils in the academic course. One reason for this situation is that pupils in the practical course could possibly have failed in some standard/class and therefore are a year older.

A similar situation is noticed in the case of the standard 7 pupils. The major percentage of pupils in the standard 7 academic course are 13 and 14 years old. In the standard 7 practical course a large proportion of the pupils are 14 and 15 years old. The mean ages in these courses are 14 years and 15 years for the academic and practical courses respectively. Here again it is concluded that a great many pupils in the practical course could possibly have failed in some standard/class during their schooling, hence they are generally a year older than pupils in the academic course in the same standard.

In the standard 8 academic and practical course it is found that the majority of pupils fall into the 14 and 15 years old age categories. There seems to be no difference in the distribution of pupils in the two courses. The reason for this is that many pupils on completing their standard 8 practical course repeat standard 8 in the academic course so that they may eventually obtain a senior certificate. In 1977 and 1978 some 16% of the academic course pupils in Indian schools in standard 8 were pupils who had followed the practical course up to standard 8, and then decided to follow the standard 8 academic course. (48)

To determine how significant the difference in age between pupils placed into practical and academic courses in the same standard is, the chi-squared statistic is computed. The obtained chi-squares (X^2) and significance levels (p) are given in the table below:

TABLE 4.16CHI-SQUARES AND SIGNIFICANCE LEVELS BETWEEN AGE AND PUPILS
IN THE ACADEMIC AND PRACTICAL COURSES

S T A N D A R D S					
6		7		8	
X ²	p	X ²	p	X ²	p
145,9	<0,01	128,96	<0,01	4,81	>0,05
df =	5	df =	5	df =	4

As an example the calculation of chi-squared for standard 6 is given below. To facilitate the calculation, a table as under is drawn up.

TABLE 4.17DISTRIBUTION OF PUPILS IN THE STANDARD 6 ACADEMIC AND
PRACTICAL COURSE IN EACH AGE CATEGORY

	AGE						TOTAL
	12	13	14	15	16	17	
Academic Course	142(a)	262(b)	71(c)	22(d)	8(e)	0(f)	503
Practical Course	56(g)	156(h)	177(i)	68(j)	20(k)	8(l)	480
	198	418	248	90	28	8	982

	A	E	A-E	(A-E) ²	$\frac{(A-E)^2}{E}$
a	142	100,9	41,1	1689,2	16,7
b	262	213,2	48,8	2381,4	11,2
c	71	126,5	-55,5	3080,3	24,3
d	22	45,9	-23,9	571,2	12,4
e	8	14,3	-6,3	39,7	2,8
f	0	4,1	-4,1	16,8	4,1
g	56	96,9	-40,9	1672,8	17,3
h	156	204,7	-48,7	2371,7	11,6
i	177	121,5	55,5	3080,3	25,4
j	68	44,1	23,9	571,2	12,9
k	20	13,7	6,3	39,7	2,9
l	8	3,9	4,1	16,8	4,3

$$\sum \frac{(A-E)^2}{E} = 145,9$$

$$\chi^2 = 145,9 \text{ for } 5df$$

$$p = < 0,01$$

From table 4.16 it is concluded that there is a significant relationship between age and the pupils being placed into academic and practical classes in standards 6 and 7. As mentioned earlier, the pupils in the practical course are generally older than pupils in the academic course in these standards. Mention has also been made of the possible reason for the difference in age between the pupils in the two courses in these standards.

From the table it is also noticed that the age difference between academic and practical course pupils in standard 8 is not significant ($p > 0,05$). A large number of pupils who complete the practical course in Std. 8 repeat standard 8 on the academic course. For this reason the age difference between the pupils in the two courses is negligible.

4.3.7.3.2 The Relationship between age and performance of pupils in tests in English and Mathematics.

The researcher aims to establish whether age has an influence on academic achievement. For this purpose a table showing the various age categories and percentage of pupils that passed the tests administered was drawn up.

TABLE 4.18

AGE CATEGORIES IN THE SAMPLE AND THE PERCENTAGE OF PUPILS THAT PASSED IN EACH ACCORDING TO STANDARD AND SUBJECT

	A G E I N Y E A R S													
	12		13		14		15		16		17		18	
	AC	PR	AC	PR	AC	PR	AC	PR	AC	PR	AC	PR	AC	PR
Mathematics Test														
Std. 6 - % pass	71,4	32,1	62,6	12,7	28,6	14,9	33,3	13,0	55,0	7,7	-	-	-	-
Std. 7 - % pass	-	-	80,0	30,2	68,5	28,2	61,5	20,3	56,7	18,2	-	16,7	-	-
Std. 8 - % pass	-	-	-	-	88,8	27,5	84,1	29,5	62,3	26,7	25,0	42,9	35,7	66,7
English Test														
Std. 6 - % pass	96,2	100	94,6	93,5	93,1	92,1	100,0	77,3	75,0	57,1	-	100	-	-
Std. 7 - % pass	-	-	100,0	100,0	98,6	91,6	93,8	94,6	66,7	83,3	-	63,7	-	-
Std. 8 - % pass	-	-	-	-	95,6	84,7	92,1	75,9	84,6	65,2	100	66,7	-	-

From the table it is observed that the younger pupils in each standard in the academic course tend to perform better than the older ones in Mathematics Tests. This however, is not the case with the practical course pupils. There seems to be wide variations in the performance of practical course pupils in the tests in Mathematics. Is there a significant relationship between age and performance in Mathematics in standards 6, 7 and 8? For this purpose the X^2 statistics is completed.

TABLE 4.19

CHI-SQUARE AND SIGNIFICANCE LEVEL IN RESPECT OF AGE AND PERFORMANCE IN MATHEMATICS

	S T A N D A R D S					
	6		7		8	
	X^2	p	X^2	p	X^2	p
Academic	24,66	$<0,01$	17,05	$<0,01$	33,71	$<0,01$
Practical	9,55	$>0,05$	3,44	$>0,05$	2,87	$>0,05$
	df =	4	df =	4	df =	4

It is concluded that there is a significant relationship between age and performance in Mathematics as far as the academic course pupils are concerned. In the case of the practical course pupils age has no bearing on performance in Mathematics. Mention has already been made of the younger pupils in the academic course who tend to perform better in Mathematics than the older ones. No valid explanation can be given as to why this is so.

In the English tests both practical and academic course pupils tend to perform equally well in each age category. To find out if there are any significant relationships between

age and performance in English the X^2 is computed. The obtained X^2 and p are reflected in the table below.

TABLE 4.20

CHI-SQUARE AND SIGNIFICANCE LEVEL IN RESPECT OF AGE
AND PERFORMANCE IN ENGLISH

	S T A N D A R D S					
	6		7		8	
	X^2	p	X^2	p	X^2	p
Academic	1,10	$>0,05$	33,93	$<0,01$	4,94	$>0,05$
Practical	5,36	$>0,05$	5,72	$>0,05$	2,84	$>0,05$
	df =	4	df =	4	df =	4

Generally there is no relationship between age and performance of pupils in tests administered in English. It is only in the standard 7 academic course that a significant relationship obtains. Here again pupils who are 13 and 14 years old tend to perform better than the older pupils.

4.3.7.4 Parental occupation and its influence on the placement of pupils into practical and academic courses

According to Miner (1968) and Chopra (1966) the fathers' occupation is generally used as an indicator of socio-economic background. (49(50)

The following categories of parental occupation are classified from the forms submitted by schools involved in this investigation:

Skilled and Semi Skilled: in this category the factory worker, shop assistants, drivers, waiters and dressmakers were placed.

White-Collar Jobs: in this category, the clerical worker, office workers, typist and persons in supervisory positions such as foreman and factory charge-hand were included.

Bussinessmen: included in this category were all persons who owned their own businesses.

Professional: doctors, lawyers and teachers were included.

For the purpose of this research the occupation groups suggested by Glass (1954) were used as a basis for drawing up the various categories. ⁽⁵¹⁾ The researcher was able to classify all parental occupations into the five categories.

Many pupils in the sample had indicated that their fathers were either deceased or unemployed. The unemployment could have been due to the economic recession which swept South Africa during the period 1976-1978. Because of the large number in these categories it is considered necessary to make mention of this fact. Table 4.21 gives the percentage of deceased and unemployed fathers in the sample.

TABLE 4.21

PERCENTAGE OF FATHERS EITHER DECEASED OR UNEMPLOYED IN THE ACADEMIC AND PRACTICAL COURSES

COURSE	S T A N D A R D S		
	6	7	8
Practical	29,0%	26,6%	32,4%
Academic	20,3%	19,1%	20,0%

The large percentage of pupils both in the academic and practical course who have parents who are either unemployed or deceased may suffer from emotional instability. The extent to which this factor influences the placement of pupils into the practical course is not known. Further it is not possible within the content of this work to arrive at any valid conclusions concerning the effect of unemployed or deceased parents on the emotional condition of pupils.

What is quite clear, however, is that whatever effect unemployed or deceased parents may have on pupils, this effect would be more pronounced among practical course pupils. ($p < 0,01$ for the 3 standards for 1df)

The distribution of the sample according to each category of fathers' occupation is given in the table below.

TABLE 4.22

DISTRIBUTION OF SAMPLE AMONG THE VARIOUS CATEGORIES OF FATHERS' OCCUPATION (PERCENTAGE WISE)

	FATHERS' OCCUPATIONS			
	SKILLED AND SEMI-SKILLED	WHITE COLLAR JOBS	BUSINESS= MEN	PROFFES= SIONAL
Standard 6				
Academic	72,0	21,0	3,0	4,0
Practical	81,2	14,3	3,0	1,5
Standard 7				
Academic	67,0	20,1	4,2	8,7
Practical	84,8	13,2	2,0	0,0
Standard 8				
Academic	63,9	23,1	9,7	3,3
Practical	77,3	19,3	2,7	0,7

The great majority of pupils in the sample for both courses in the various standards have fathers who are employed as skilled and semi-skilled workers. However more fathers of the practical course pupils than the academic course pupils are employed as semi-skilled or skilled workers. It is also interesting to note that more fathers of academic course pupils are employed in the professional field.

Is there a significant difference in the occupations of fathers and the pupils being placed into practical and academic courses in Indian Schools? To ascertain this the chi-squared statistic is used. Table 4.23 reflects the obtained X^2 and p for the relationship between fathers' occupation and the pupils being placed into practical and academic courses.

TABLE 4.23

CHI-SQUARE AND SIGNIFICANCE LEVEL FOR FATHERS' OCCUPATION AND PUPILS PLACED INTO PRACTICAL AND ACADEMIC COURSES IN THE SAMPLE

S T A N D A R D S					
6		7		8	
X^2	p	X^2	p	X^2	p
10,36	< 0,05	50,4	< 0,01	23,22	< 0,01
df		=	3		

An example of how the X^2 and p were calculated is given below. The example for standard 6 is done.

STANDARD 6

	SEMI-SKILLED AND SKILLED	WHITE COLLAR JOBS	BUSI.	PROF.	TOTAL
Practical	291	85	12	16	404
Academic	267	47	10	5	329
	558	132	22	21	733

	A	E	A-E	(A-E) ²	$\frac{(A-E)^2}{E}$
a	291	307,5	-16,5	272,3	0,89
b	85	72,8	12,2	148,8	2,04
c	12	12,1	- 0,1	0,0	0,00
d	16	11,6	4,4	19,4	1,67
e	267	250,5	16,5	272,3	1,09
f	47	59,2	-12,2	148,8	2,51
g	10	9,9	0,1	0,0	0,00
h	5	9,4	- 4,4	19,4	2,06

$$\sum \frac{(A-E)^2}{E} = 10,26$$

$$df = 3$$

$$p < 0,05$$

The table indicates that there is a significant relationship between fathers' occupation and the placement of pupils into the practical and academic courses in Indian schools. Generally more parents of the practical course pupils are employed as semi-skilled and skilled workers. In an investigation conducted by Banks and Finlayson (1973) it was found that there is a very consistent relationship between fathers' occupation and academic performance of pupils. ⁽⁵²⁾ The findings of Banks and Finlayson are supported by this investigation. However mention needs to be made of the investigation conducted by Naguran (1978) in which it was found that fathers' occupation does not

influence academic performance. (53) Naguran did not use a sample of academic and practical course pupils, his sample was restricted to only academic course pupils. (54)

4.3.7.5 I.Q. and its influence on the placement of pupils into practical and academic courses

Tests of intelligence measure an individual's overall ability or capacity to learn. (55) They differ from achievement tests, e.g. tests in Mathematics and English, which measure the extent of an individual's learning. (56)

The intelligence test commonly used in Indian schools is the Group Test for Indian South Africans known as the GTISA. The composition of the GTISA and its use in Indian education have been discussed in Chapter 1. In Chapter 3 the distribution of intelligence in the population at large based on test results obtained with the New South African Group Test is outlined. The distribution of intelligence obtained with the GTISA is the same as that of the New South African Group Test.

In this research pupils were categorised according to their I.Q. scores into the following categories based on the GTISA. The categories, with the percentage of the population in each, are listed in Chapter 3.

I.Q. score	Ability Grouping
69 and lower	Sub-normal
70 to 79	Borderline
80 to 89	Dull-normal
90 to 109	Average
110 to 119	Above Average
120 to 129	Superior
130 and above	Very Superior



Although this investigation is concerned with pupils being placed into practical and academic classes in standards 6, 7 and 8, the relationship between I.Q. and scholastic attainment will be investigated only for standards 7 and 8. Very few I.Q. scores were available for pupils in standard 6. This is due to the policy of the Department of Indian Affairs, Division of Education which administers the I.Q. tests to standard 6. Only if time is available is it administered to the standard fives. (57)

4.3.7.5.1 The Distribution of pupils according to I.Q. in the Academic and Practical Courses.

The distribution of pupils according to I.Q. in standards 7 and 8, academic and practical courses, is given in the table below.

TABLE 4.24

DISTRIBUTION OF PUPILS ACCORDING TO I.Q. IN STANDARD 7 AND 8, ACADEMIC AND PRACTICAL COURSES, IN PERCENTAGE

I.Q. SCORE	ABILITY GROUPINGS	Std. 7		Std. 8	
		Aca= demic	Prac= tical	Aca= demic	Prac= tical
1. 69 and lower	Sub-normal	-	-	-	-
2. 70 to 79	Borderline	-	-	-	-
3. 80 to 89	Dull-normal	1,6	10,2	1,9	6,7
4. 90 to 109	Average	32,8	67,2	33,0	57,7
5. 110 to 119	Above Average	34,4	19,3	38,4	28,4
6. 120 to 129	Superior	21,8	3,3	18,4	6,9
7. 130 and above	Very Superior	9,4	0,0	8,3	0,3

From the table it is noticed that only about 10% of the pupils in the standard 7 practical course can be classed as dull-normal. Some 90% of the pupils with average and above intelligence are also found in this course. In the standard 8 practical course the situation is more or less the same, only about 7% of the pupils can be classified as dull-normal. About 93% with average and above intelligence are also found in this course. The number of dull-normal pupils found in the standard 7 and 8 academic courses is negligible (about 2%).

From the above it is concluded that other factors rather than intelligence are responsible for the large number of pupils falling into the practical course. Burt (1950), Emmet (1947), McClelland (1942), Sigel (1971) and more recently Eunice Barendse (1978) have confirmed the view that the best single indicator of academic potential is the intelligence test. (58)(59)(60)(61)(62) Since placement of pupils into the practical course is based solely on the performance of pupils in the school examination, it is reasonable to conclude that the school examination used alone is not a valid instrument for selecting pupils for the practical course.

Is there a significant difference between the I.Q.'s of pupils placed into the practical course and those placed into the academic course? To determine the significance the X^2 statistic is used. Table 4.25 gives the X^2 and p for the standards 7 and 8 pupils in the sample.

TABLE 4.25

CHI-SQUARES AND SIGNIFICANCE LEVELS FOR PUPILS PLACED
INTO PRACTICAL AND ACADEMIC COURSES IN STANDARDS 7 AND 8

S T A N D A R D S		
	7	8
X ² :	143,7	98,09
p :	<0,01	<0,01
df:	4	4

An example of how the X² and p were calculated is given for standard 7.

STANDARD 7

	I.Q. SCORES					Total
	80-89	90-109	110-119	120-129	130+	
Academic	7(a)	137(b)	144(c)	91(d)	39(e)	418
Practical	28(f)	184(g)	53(h)	9(i)	0(j)	274
	35	321	197	100	39	692

	A	E	A-E	(A-E) ²	$\frac{(A-E)^2}{E}$
a	7	21,1	-14,1	198,9	9,4
b	137	193,9	-56,9	3237,6	16,7
c	144	119,0	25,0	625,0	5,3
d	91	60,4	30,6	936,4	15,5
e	39	23,6	15,4	237,2	10,0
f	28	13,9	14,1	198,8	14,3
g	184	127,1	56,9	3237,6	25,5
h	53	78,0	-25,0	625,0	8,0
i	9	39,6	-30,6	936,4	23,6
j	0	15,4	-15,4	237,2	15,4

$$X^2 = 143,7$$

$$df = 4$$

$$p = < 0,01$$

There is a significant difference between the I.Q. scores of pupils being placed into the practical and academic courses. The majority of pupils being placed into the practical course have an I.Q. range of 90 to 109. An I.Q. of 90 to 109 is considered to be average intelligence. The range of I.Q. of pupils in the academic course is 110 to 119. An overview of the intelligence scores of pupils in the academic and practical course indicates that the practical course in Indian schools is in actual fact catering for pupils of average intelligence and the academic course for pupils of above average intelligence.

4.3.8 Summary of findings

The performance of pupils in the tests administered in English and Mathematics reveals that the practical and academic course pupils are generally two distinct groups. The overall performance of the academic groups (standards 6, 7 and 8) in the two tests was better than that of the practical groups.

However it is interesting to note that some 7% of the pupils in standards 6, 7 and 8 academic course combined, had failed the tests administered in English and Mathematics. Since the tests tested content covered in the standards 5, 6 and 7 academic course, it is reasonable to conclude that these pupils were wrongly placed into the academic course. They should in actual fact have been placed into the practical course.

The situation is different in respect of the practical course pupils performance in the two tests. Some 30% of the pupils in the practical course (standards 6, 7 and 8 combined) passed the English and Mathematics tests. These pupils, according to their performance in the tests, should have been placed into the academic course.

Since placement in Indian schools is based solely on performance of pupils in the school examination, it is concluded that the school examination used alone is not a valid instrument for placing pupils into practical and academic courses.

It was also found that pupils in the practical course are generally older than pupils in the academic course in the same standard.

The fathers of practical course pupils are generally employed in skilled and semi-skilled jobs. Since fathers' occupation, is related to socio-economic conditions, it is reasonable to conclude that children from the lower socio-economic groups more easily find themselves into practical courses.

In respect of intelligence it is found that there is generally a difference in the intelligence of pupils being placed into practical and academic courses. In the main pupils of above average intelligence are placed into the academic course and those with average intelligence into the practical course. Some 23% of pupils in the standard 7 practical course and some 35% of pupils in the standard 8 practical course (Table 4.24) with above average intelligence are found in practical course.

REFERENCE

1. GOOD, C.V. : Introduction to Educational Research,
Appleton-Century-Crafts, New York,
1963 pp. 244-245
2. BORG, W.R. : Educational Research - An Introduction,
David McKay Company, New York, 1967
pp. 202-203
3. BEHR, A.L. : Methods and Techniques in Educational
and Psychological Research, van
Schaik, Pretoria, 1973 p. 10
4. IBID
5. DEPARTMENT OF INDIAN AFFAIRS : Research File No. 19/43/3/2
(DIVISION OF EDUCATION)
6. THE JOINT MATRICULATION BOARD : Minutes of Meeting held in Pretoria
on Tuesday 13 January 1976 p. 18
7. DEPARTMENT OF INDIAN AFFAIRS : Minutes of the 18th Examination's
(DIVISION OF EDUCATION) Boards Meeting held in Durban on
Friday 8 October 1977 p. 10
8. THE JOINT MATRICULATION BOARD : op. cit., pp. 18-24
9. DEPARTMENT OF INDIAN AFFAIRS : Research File No. 19/34/3/2
(DIVISION OF EDUCATION)
10. DEPARTMENT OF INDIAN AFFAIRS : Circular No. 28 of 1972, File No.
(DIVISION OF EDUCATION) 19/15/6/2
11. DEPARTMENT OF INDIAN AFFAIRS : File No. 19/20/6/2
(DIVISION OF EDUCATION)
12. WILLIAMS, I.C. AND BOREHAM, N.C. : The Predictive value of CSE grades
for further education, Evans/
Methuens, London, 1972 p. 15
13. NUTTAL, J.K. BLACKHOUSE, J.K. : Comparability of standards between
AND WILLMOTT, A.S. subjects, Evans/Methuens, London,
1974 p. 118
14. DEALE, R.N. : Assessment and testing in the Secondary
School, Evans/Methuens, London, 1976
pp. 78-110
15. TRANSVAAL ONDERWYSBURO : Verslag oor die Matrikulasie -
Eksperiment van die Transvaalse
Onderwysdepartement, 1971 pp. 57-58

16. OLIVIER, K. : "The Year Mark Experiment in Natal",
Mentor, October 1978 pp. 157-160
17. DEPARTMENT OF INDIAN AFFAIRS : File No. 19/20/6/2
(DIVISION OF EDUCATION)
18. SCHOOL COUNCILS PUBLICATION : Examinations, London, March 1977
pp. 1-4
19. TAWNEY, D. : "Curriculum evaluation today -
trends and implications", Schools
Councils Research Studies, MacMillan,
London, 1976 p. 53
20. INGRAM, E. : Cited by Entwistle, N.S. and Nisbet,
J.D. in Educational Research in Action,
University of London Press, London,
1972 p. 198
21. DEPARTMENT OF INDIAN AFFAIRS : File No. 19/20/6/2
(DIVISION OF EDUCATION)
22. McCLELLAND, W. : Selection for Secondary Education,
University of London Press, London,
1949 pp. 191-236
23. SUGDEN, M.A. : Chatsworth, Social and Economic
Characteristic of Population",
Journal of the University of Durban-
Westville, Vol. 1, No. 2, 1972 p. 70
24. DEPARTMENT OF INDIAN AFFAIRS : File No. 19/46/2
(DIVISION OF EDUCATION)
25. BORG, W.R. : op. cit., pp. 171-174
26. BEST, J.W. : Research in Education, Prentice-
Hall, United States, 1959 pp. 204-205
27. BORG, W.R. : op. cit., pp. 171-174
28. DOWNIE, N.M. AND HEATH, R.W. : Basic Statistical Methods, Second
Edition, Harper and Row, New York,
1965 pp. 316-317
29. DEPARTMENT OF INDIAN AFFAIRS : Circular No. 49 of 1975,
(DIVISION OF EDUCATION) File No. 19/20/14/2
30. LANDMAN, W.J.J. : Discussion held with Mr. Landman,
Education Planner - Natal Education
Department, Pietermaritzburg,
6 October 1978

31. TRANSVAAL EDUCATION DEPARTMENT : Interdepartementele Advieskomitee Insake Differensiasie, Kurrikulum en Voorligting vir die Sekondêre skool, 1972
32. BORG, W.R. : op. cit., pp. 138-140
33. DOWNIE, N.M. AND HEATH, R.W. : op. cit., pp. 160-165
34. BEHR, A.L. : op. cit., p. 11
35. FERGUSON, G.A. : Statistical Analysis in Psychology and Education, McGraw-Hill and Co., New York, 1976 p. 187
36. DOWNIE, N.M. AND HEATH, R.W. : op. cit., pp. 188-203
37. BEHR, A.L. : op. cit., p. 96
38. IBID : p. 99
39. LINDQUIST, E.F. : Statistical Analysis in Educational Research, Houghton Mifflin, 1940 pp. 17-20
40. BEHR, A.L. : op. cit., pp. 87-88
41. STROBEL, M.G. AND DUDEK, S.Z. : "On the Testing of Tests", Paper presented at the Annual Convention of the American Psychological Association, New Orleans, Louisiana, 1974
42. DONLON, T.F. : "Testing in the affective Domain", Measurement and Evaluation, Princeton, New Jersey, 1974 p. 32
43. ERLICK, O AND OGILVIE, V.N. : Coverage and content validity of vocational career Education Tests, Washington, D.C., 1975 pp. 4-15
44. BEHR, A.L. : op. cit., p. 100
45. PINTER, R. AND FORLANO, G. : Cited by Pidgeon, D.A. in "Date of Birth and Scholastic performance", Educational Research, Vol. 8, No. 1, November 1965 pp. 3-7
46. FITT, A.B. : cited by Pidgeon, D.A. in "Date of Birth and Scholastic performance", Educational Research, Vol. 8, No. 1, November 1965 pp. 3-7

47. JONES, H.E. : "The Environment and Mental Development", Manual of Child Psychology (2nd Edition) Chapman and Hall, London, 1954 pp. 631-696
48. DEPARTMENT OF INDIAN AFFAIRS : Statistics File No. 19/46/2
(DIVISION OF EDUCATION)
49. MINER, BETTY : "Sociological Background Variables Affecting School Achievement", Journal of Educational Research, Vol. 1, No. 8, April 1968 pp. 372-380
50. CHOPRA, S. : "Family Size and Sibling Position as related to measured intelligence and academic achievement", The Journal of Social Psychology, Vol. 70, 1966 pp. 133-137
51. GLASS, D.V. : Social Mobility in Britain, Routledge, London, 1954
52. BANKS, OLIVER AND FINLAYSON : "Success and Failure in the Secondary School", An Interdisciplinary approach to School Achievement, Methuen and Co., London, 1973 p. 92
53. NAGURAN, C.A. : "A study of Failure in School with special reference to Indian Secondary Education in Natal", Unpublished M.Ed. Thesis, University of Durban-Westville, 1978 p. 211
54. IBID
55. BEHR, A.L. : op. cit., p. 36
56. IBID
57. DEPARTMENT OF INDIAN AFFAIRS : File No. 19/34/2
(DIVISION OF EDUCATION)
58. BURT, C. : "Symposium on the Selection of Pupils for Different Types of Secondary Schools", British Journal of Educational Psychology, Vol. 20, February 1950 p.1
59. EMMETT, W.G. : "Secondary Modern and Grammar School Performance predicted by tests given in Primary Schools", British Journal of Educational Psychology, Vol. 23-24, 1953-1954 p. 97.

60. McCLELLAND, W. : Selection for Secondary Education,
University of London Press, London,
1947 p. 4
61. SIGEL, I.E. : "How Intelligence Tests limit
understanding of Intelligence",
Readings in Research in Development
Psychology (editor Gordon, I.J.),
Scott Foresman and Company, London,
1971 pp. 279-290
62. BARENDSE, EUNICE : "Giftedness", Mentor, Vol. 60,
No. 5, October 1978 pp. 141-143

CHAPTER 55. GENERAL CONCLUSIONS AND RECOMMENDATIONS5.1 LIMITATIONS OF THE PRESENT STUDY

Before summarizing the findings, it is necessary to draw attention to some of the limitations of the present study.

In the first Chapter of this investigation an overview of measuring instruments used in Indian schools was given. The tests set in Mathematics for this investigation presented no problems in so far as marking was concerned. The marking was fairly objective. It is in the marking of the essay type questions set in the English tests that the researcher expresses concern. However, the essay type question could not be left out from this investigation because it is very much part of the internal examination set by schools. Precautions were taken against obtaining widely disparate assessments by marking the essay type answers twice by two different examiners. This procedure is used in the marking of essay type questions set for the Senior Certificate Examination by the various Education Departments.

Vernon (1962) contends: "The standards of marking even of a single examiner are liable to alter with fatigue and mood. When marking large numbers of answers to the same question, he may begin very strictly and then gradually become more lenient or vice versa. The same script might receive a different mark if read after, instead of before dinner." (1)

Although the essay type question formed part of the tests administered in English, there were other sections tested in the same papers that could be marked objectively viz grammar and comprehension.

To a large extent items of the objective type were used in constructing the tests in Mathematics and English. (The advantages and disadvantages of this type of test have been dealt with in Chapter 1). Therefore in marking the Mathematics tests and to a limited extent, the English tests, the subjective element in scoring was eliminated. However, one needs to be cognisant of Behr's injunction in respect of objectivity. Behr (1971) states that the items in an objective type test are subjective (as are indeed all examination questions) in the sense that "the examiner is the sole arbiter as to the content to be covered and the skills to be tested".⁽²⁾ Nevertheless this aspect of subjectivity is reduced to a minimum by the wide content coverage which this type of test offers. In the tests used in this investigation the panel of examiners set questions on virtually every section of the syllabus expected to be covered by pupils during the previous year.

Another limitation of this investigation is the lack of I.Q. scores for the standard 6 pupils. No conclusions relating to I.Q. and placement of pupils into the standard 6 academic and practical courses are drawn.

Assessment and Measurement in education are influenced by many factors. Factors such as socio-economic background, emotional and psychological development and intelligence of pupils have a bearing on educational achievement. Parental motivation and interest in education also influences the academic achievements of children. Further there is no doubt about the influence that teachers have on the scholastic attainment of pupils. Williams (1965) found that among the factors that may affect a pupil's attainment in a subject, teachers-ability is perhaps the most important.⁽³⁾ The ability to motivate and stimulate pupils is of paramount importance in the learning situation.

5.2 DISCUSSION OF FINDINGS

5.2.1 Performance of pupils in tests in English and Mathematics

Mention has been made in Chapter 2 of the two subjects that present a problem to the great majority of pupils in standards 5, 6 and 7. It was found that some 63% of pupils in standards 5, 6 and 7 combined failed Mathematics in the internal school examinations and some 30% of pupils in the same standards combined failed English. It was also pointed out that poor performance in these two subjects was the major cause of pupils being placed into the practical and academic courses in Indian schools.

The tests administered in this investigation in English and Mathematics to the various standards served as external examinations in these subjects. Although the overall performance of the academic course pupils were better than that of the practical course pupils, the tests revealed that some 7% of the pupils in the academic course and some 30% in the practical course were wrongly placed. This suggests that a carefully set and corrected external examination would be a better instrument than the internal school examination for placement of pupils into practical and academic courses. In a similar investigation conducted by McClelland (1949) to determine the best single measure to predict secondary school performance, McClelland concluded that the internal school examination used alone is not a valid instrument for prediction. ⁽⁴⁾ Having stated his conclusion in a scientific way McClelland goes on to say, "but as educationists" we must be "alive to the evils of external examinations." ⁽⁵⁾

Educationists such as Brereton (1944), Himmilweit (1967) and Pilliner (1968) support the view taken by McClelland. ⁽⁶⁾⁽⁷⁾⁽⁸⁾ It has been argued that external examinations impose on schools a common syllabus which may "stifle initiative and

militate against the diversity among schools." (9) By its very nature, the external examination depresses "the status of aesthetic and creative aspects of education." (10)

In South Africa the only external examination written by pupils is the Senior Certificate Examination of the education department concerned. The trend in this country is to place more emphasis on teachers assessment than on performance in an examination. This has led to experiments by the different education departments. (The Transvaal Education Departments-Project School experiment, the Natal Education Departments-Year Mark experiment). (11)(12)

These experiments are aimed at giving the teacher more say in the assessment of pupils in the senior secondary phase and at the same time reducing the effects of the external examination on pupils.

From the foregoing it is quite clear that the use of external examinations for purposes of selecting pupils for the practical and academic courses in Indian schools is out of the question.

However the use of some form of standardized scholastic attainment tests in English and Mathematics would give some indications as to the course a pupil should be placed into; and at the same time such tests would be free from the evils of the external examination. Such tests, however, are not presently available for use in Indian schools.

5.2.2 The influence of age on scholastic achievement

In this investigation it was found that pupils being placed into the practical course are generally a year older than pupils being placed into the academic course. As mentioned in Chapter 4, one possible reason for the difference in age

is that many pupils in the practical course could possibly have failed during their school career.

In investigations conducted by Pidgeon and Dodds (1961) it was found that older children in the primary school perform better than the younger ones in the same standard. (13) Studies by Anderson (1964) and Postletharquite (1965) indicate that by the time children reach secondary school, age has no significant effect on scholastic attainment. (14)(15) Since only some 8% of pupils in standards 7 and 8 practical course combined, may be classified as dull-normal in Indian schools (Chapter 4) it is reasonable to conclude that the majority of pupils placed into the practical course are underachievers. The causes of underachievement have been discussed in Chapter 3.

5.2.3 Father's occupation as an indicator of socio-economic background of the pupil

In Chapter 4 mention has been made of the relationship between fathers' occupation and socio-economic background. It was pointed out that the father's occupation is generally used as an indicator of socio-economic background.

In an investigation conducted by Dale and Griffith (1965) the father's occupation was used to indicate the effects of socio-economic conditions on academic achievement. (16) Dale and Griffith concluded that academic deterioration is most common among the children of unskilled and semi skilled workers. (17) This investigation pointed out that most children of semi skilled and skilled workers were found to be in the practical course. Swift (1966) states that parental encouragement has an important bearing upon school motivation and performance. (18) Wall (1962) concluded that "children, particularly boys, do very much

better at school if their parents are interested in their progress" and that children whose parents are rated as "very interested" improve their test scores between 8 and 11%, but those children whose parents are uninterested show a deterioration in score. ⁽¹⁹⁾ Douglas (1964) also suggested that children tend to work well when their parents take an interest in their school progress and to work badly when they are uninterested. ⁽²⁰⁾ Naguran (1978) found generally a positive relationship between parental level of education and the academic performance of Indian pupils. The higher the educational level of parents, the better was the performance of their children. ⁽²¹⁾

From the foregoing it may be concluded that as the educational level of Indian parents increase the interest shown by pupils in education will also increase. This may have a beneficial effect in that the number of underachieving pupils in Indian schools may decrease.

5.2.4 The Relationship between I.Q. and placement of pupils into practical and academic courses

In an investigation conducted by McClelland on the selection of pupils for the different types of secondary schools in Britain, it was found that the best single predictor of success in a course is I.Q. ⁽²²⁾ Several authorities of whom mention has been made in Chapter 4 contend that the best single indicator of academic potential is the intelligence test.

In this investigation it is found that some 93% of pupils with average and above intelligence are placed into the practical course in standards 7 and 8. This large percentage is due to several factors among which are the internal school examination and the socio-economic background of the pupil.

It is not the lack of intelligence but achievement in the internal school examination that results in many pupils being placed into the practical course.

5.3 RECOMMENDATIONS

In the light of the findings the following recommendations are suggested.

5.3.1 Promotion from one class to the next and selection for academic and practical courses at the end of standards 5, 6 and 7

Presently in Indian schools the internal school examination in standards 5, 6 and 7 is used for both promotion and selection purposes. Details concerning the promotion and selection procedures have been discussed in Chapter 2.

Since promotion from one class to the next and selection for practical and academic courses are two different issues, the researcher is of the opinion that the criteria used for each should also be different.

While promotion is based on the general scholastic attainment of pupils at a particular time in their lives, selection procedures for the practical and academic courses should consider the pupil's potential as reflected by I.Q., aptitude, ability and interest in a particular course of study. Selection should follow on promotion.

A distinction between promotion and selection requirements needs to be made.

5.3.1.1 Promotion procedures in standards 5, 6 and 7

The promotion procedures currently used in Indian schools have been mentioned in Chapter 2.

From the details given in that Chapter it is clear that promotion and selection are considered together.

In standard 5 the subjects are grouped as follows:

- Group 1 : English First Language
- Group 2 : Afrikaans Second Language
- Group 3 : Mathematics and General Science
- Group 4 : History and Geography.

The minimum requirements for promotion into the academic and practical courses are as follows:

	Pass into std. 6 Academic Course	Pass into std. 6 Practical Course
Group 1	45%	35%
Each of <u>two</u> of the remaining groups	40%	35%
Aggregate	50%	35%

The Natal Education Department also considers selection and promotion together. In standard 5 the following are the pass requirements employed by the Natal Education Department. (23) (24)

	Pass into std. 6 Academic Course	Pass into std. 6 Practical Course
First Language	40%	33' / ₃ %
Second Language	33' / ₃ %	33' / ₃ %
In <u>two</u> of Mathematics, History, Geography and General Science	40%	33' / ₃ %
Aggregate	40%	33' / ₃ %

From the foregoing it is quite clear that selection for the different types of secondary school courses is combined with promotion in these Departments. The researcher feels (as mentioned earlier) that promotion and selection for the different courses should not be combined.

It is therefore suggested that the promotion requirements for standard 5 in Indian Schools should be:
 main language $33\frac{1}{3}\%$, second language $33\frac{1}{3}\%$, in two of Mathematics, History, Geography and General Science $33\frac{1}{3}\%$ and aggregate $33\frac{1}{3}\%$.

In standards 6 and 7 in addition to the standard 5 requirements for promotion, $33\frac{1}{3}\%$ in one of third language, Technical Drawing, Music, Art, Accountancy and Typing is suggested. (These are additional subjects some of which are taken by pupils in standards 6 and 7).

Once the pupil has been promoted, consideration should be given to his placement into the academic or practical course.

5.3.1.2 The procedure to be followed in selecting pupils for the academic and practical courses

The findings in this research indicate that it would be unwise to use the results of the internal school examination exclusively in determining the course that a pupil should be placed into in secondary schools.

The researcher is of the opinion that performance in English and Mathematics in the internal school examination and a consideration of several other factors namely, previous school performance, I.Q., scholastic attainment tests in English and Mathematics and teachers' estimates

of a pupils potential should be taken into account when a decision is made on the type of course a pupil should follow. Authorities such as McClelland (1949), McIntosh (1949), Vernon (1962), Burt (1948) and Dempster (1948) agree that selection for the different types of secondary school courses should be based on many factors and not on a single examination. (25)(26)(27)(28)(29)

The other instruments, apart from performance in English and Mathematics in the internal school examination, that should be used for selection purposes will now be discussed.

Previous school performance

Records of previous scholastic performance of pupils are kept on a card called the cumulative record card (I.E.18). (30) This card reflects the previous performance of pupils subject-wise in the various standards from class one. The record card in respect of each pupil is completed at the end of each year by the class teacher. When the pupil is transferred from one school to another the cumulative record card is posted to the new school. Similarly, when a pupil is transferred from primary to secondary school this card is posted to the secondary school concerned.

The cumulative record card gives an indication of the pupils performance in the previous years and could therefore be used to compare a pupil's present and previous performance in a subject or in the examination as a whole. The researcher feels that the cumulative record card is a valuable document which could guide teachers when making a decision on the type of course a pupil should follow.

How the information on this card could be used for selection purposes will be discussed later.

Intelligence test scores (I.Q.)

The importance of I.Q. scores for purposes of selection have been emphasised throughout this thesis. It is therefore suggested that I.Q. tests be administered to pupils in standards 4 and 5 so that by the end of standard 5, the I.Q. scores of all pupils should be available.

To enable this to be done (and to ensure that the I.Q. is a valid and reliable index) the psychological section of the Division of Indian Education needs to be expanded and furthermore special teachers should be made accredited testers. The Group Test for Indian South Africans (GTISA), referred to in Chapter 1, should be administered. ⁽³¹⁾ The use of I.Q. scores in the selection process will be discussed later.

Scholastic Attainment Tests

Scholastic attainment tests in Mathematics and English for standards 5, 6 and 7 are currently being prepared by the Human Science Research Council. These tests are expected to be ready for use in Indian schools in 1980. ⁽³²⁾

To measure the general level of scholastic attainment of pupils in the same standard in the various schools under the control of the Department of Indian Affairs and to establish a cut-off point for the number of pupils that should be promoted into each course it is suggested that standardised scholastic performance tests in the two major subjects i.e. English and Mathematics be used.

Mention has already been made in Chapter 2 of Behr (1971) and Muller (1968) who feel that the practical course pupils should constitute \pm 16% of the secondary school population. Apart from being used to establish cut-off points, the scholastic attainment tests could be used, as will be shown later, for purposes of selection.

Teachers estimate of pupil's response to the learning situation.

The teachers estimate should be based on the following aspects. These aspects have been adapted from Behr (1977). (33)

A. Study Habits

- 1 Good use of time made at school
- 2 Concentration on task at hand
- 3 Work undertaken independently
- 4 Classwork kept up to date.

B. Attitude-Interests

- 1 Interest in classwork
- 2 Alertness and responsiveness in class
- 3 Friendliness and courtesy to others
- 4 Extra help sought when need for it is felt
- 5 Reaction to new and different tasks
- 6 Additional information and ideas asked for
- 7 Ability to use knowledge
- 8 Interest in educational future
- 9 Completion of projects and assignments.

The assessment of pupils on these items will be discussed later.

5.3.1.3 The use of the various instruments, mentioned above, for selection purposes

Since a complex statistical procedure for selection of pupils for practical and academic courses would be confusing and time consuming to many teachers, the researcher suggests a simple procedure which could be used by all teachers, even those with a limited statistical background.

In order to give more or less equal weighting to pupils performance in English and Mathematics in the internal school examination, I.Q., performance in scholastic attainment tests in English and Mathematics and teachers estimates, some form of standardised procedure needs to be employed. For this purpose it is felt that stanines could be used effectively. The stanine is a nine point scale with a mean of 5 and a standard deviation of 1,96. (34) (35) The percentage of candidates in any random sample that should fall into a stanine-score category from 1 to 9 is given below:

Stanines :	1	2	3	4	5	6	7	8	9
% of Cases :	4	7	12	17	20	17	12	7	4

Pupils on having passed the standard 5, 6 and 7 school examinations should be assessed on the nine point scale so that a decision could be made on the type of course that they should be placed into in secondary schools.

The conversion of the various instruments, that should be used for selection, into stanines will be as follows:

Conversion of internal school examination scores in English and Mathematics into stanines

The percentage obtained by pupils in each of the subjects i.e. English and Mathematics should be converted to a stanine separately.

Pupil attainment in English and Mathematics	Stanine
80% +	9
70 - 79	8
60 - 69	7
50 - 59	6
40 - 49	5
33 - 39	4
30 - 32	3
20 - 29	2
0 - 19	1

The above conversion was worked out by making stanine 4 to cater for the borderline cases. Pupils who just managed to pass by obtaining anything between 33 and 39% are regarded as borderline and therefore need special consideration. Stanine 3 and below include pupils who have failed, while stanine 5 and above include pupils who have passed.

Example of conversion of % to stanine: A pupil who obtains 52% in English and 35% in Mathematics would have stanine scores of 6 and 4 respectively.

In addition since the scholastic attainment tests in English and Mathematics will be finalised by the Human Science Research Council in 1980, performance in these tests could also be converted to stanines on lines similar to that mentioned above.

Conversion of I.Q. scores to stanines

The following conversions in respect of I.Q. scores should be adopted. The conversion has been adapted from Behr (1973). (36)

I.Q. Score	Stanine
130+	9
118 - 129	8
111 - 117	7
106 - 110	6
99 - 105	5
90 - 98	4
80 - 89	3
71 - 79	2
70 and lower	1

Conversion of teachers estimates to stanines

Each item mentioned in paragraph 5.3.1.2 (teachers estimates) must be rated on the following scale.

	Stanine
Outstanding	9
Very Good	8
Good	7
Above Average	6
Average	5
Needs to Improve (can improve)	4
Unsatisfactory	3
Weak	2
Poor	1

The total number of items under teachers estimates are 13. (See appendix VI). Pupils are assessed on each item and given a stanine score. Thereafter the 13 scores are added to give a total. The total is once again converted into a stanine score on the following basis:

Total Score on teachers' estimate	Stanine
117 - 105	9
104 - 92	8
91 - 79	7
78 - 66	6
65 - 53	5
52 - 40	4
39 - 27	3
26 - 14	2
13	1

The conversion of teachers estimates to stanines was arrived at by multiplying the total number of items (appendix VI) by each stanine category. The number of items in each stanine category was 13. Therefore the total score in stanine 9 is $13 \times 9 = 117$ and in the case of stanine 8 it is $13 \times 8 = 104$. The scores in stanine 9 therefore ranges from 117 to 105 (105 is one more than the highest score in stanine 8).

Once the performance of pupils in Mathematics and English in the internal school examination, performance in scholastic attainment tests in English and Mathematics, teachers' estimates and I.Q. scores have been converted into stanine scores, the scores should be entered on a profile form for each child. An example of such a form is given below:

PROFILE FORM FOR SELECTION FOR ACADEMIC AND PRACTICAL COURSES

NAME OF PUPIL STD AGE

NAME OF SCHOOL

NAME OF TEACHER

Selection Instruments:	Ee	Em	Se	Sm	Te	I.Q.	Total
Stanines	:						

Key

- | Symbol | Description |
|--------|---|
| Ee | - English score in internal school examination converted to stanine. |
| Em | - Mathematics score in internal school examination converted to stanine. |
| Se | - English score in scholastic attainment test converted to stanine. |
| Sm | - Mathematics score in scholastic attainment test converted to stanine. |
| Te | - Teachers estimate based on profile form (appendix VI) converted to stanine. |
| I.Q. | - Total of the six stanine scores i.e. Ee+Em+Se+Sm+Te+I.Q. = Total |

Converted total score _____ stanine score

Recommendation: Practical/Academic Course.

 PRINCIPAL

 CLASS/Form TEACHER

 DATE

 DATE

The total score obtained by each pupil on the profile form is converted to a stanine score as follows:

Total Score	Stanine
54 - 49	9
48 - 43	8
42 - 37	7
36 - 31	6
30 - 25	5
24 - 19	4
18 - 13	3
12 - 7	2
6	1

Six scores make up the total score on the profile form on page 196 i.e.

$$Ee + Em + Se + Sm + Te + I.Q. = \text{TOTAL}$$

By multiplying each stanine category by 6 the total score for each category is obtained. For example the highest score in stanine 7 is $7 \times 6 = 42$ and in stanine 6 it is $6 \times 6 = 36$. Therefore stanine 7 ranges from 42 to 37 (37 is one more than the highest score in stanine 6).

Pupils who obtain a stanine of 5 and above should be placed into the academic course (stanine 5 is the mean) and those with a stanine 3 and below should be placed into the practical course. Those that obtain a stanine score of 4 need further consideration before placement into any course.

In the case of pupils who obtain a stanine score of 4, the previous school performance recorded on form I.E.18 should be scrutinized. Decisions in the case of these pupils should be made at a meeting in which the teachers concerned, principal and guidance counsellors are present.

If the general performance of pupils in the school examinations in the previous years is considered to be satisfactory then these pupils should be given a chance to continue their studies on the academic course. If there is a consistently poor rating in the child's performance in the previous school examinations, then such a child should be placed into the practical course.

The writer is of the opinion that the final decision on the course that a pupil should follow in secondary schools should rest with the schools. However, the matter of placement of a pupil into the practical must be discussed with the parent. The parent should be made to feel that the school is acting in the best interest of his child. Apart from being used for selection purposes the stanine scores will indicate the subjects in which pupils are underachieving. The I.Q. score of a pupil to some degree reflects on the learning ability of a pupil.

For example if a pupil obtains a stanine of 5 for I.Q., a stanine of 5 for mathematics and a stanine of 3 for English, then this pupil is definitely underachieving in English.

Further the stanines obtained by candidates in school examination subjects and attainment tests would indicate the "standard" of internal school examinations in a particular school. For example let us consider the stanine scores obtained by pupils in two different schools in Mathematics in the internal school examination and attainment tests in the same subject.

Can= di= dates	School A		School B	
	Attainment Test	School Examination	Attainment Test	School Examination
1	6	4	6	8
2	5	4	5	6
3	7	6	7	8
4	4	3	4	5
5	2	1	2	3

From the above it may be concluded that the internal school examination in Mathematics in school A is more difficult than the examination in the same subject in school B. The stanines could, therefore, be used by schools to view the "standard" of the internal school examination in the various subjects with greater circumspection.

The procedure set out above for selection purposes have not been tested out on any group of pupils. However, as an employee of the Division of Indian Education, the researcher intends carrying out a pilot study along the lines discussed above. On the research evidence available, such a procedure is likely to produce a more effective selection process.

Other recommendations that also arise out of this investigation will now be discussed:

5.3.2 School Guidance Counsellors for Primary Schools

Presently school guidance counsellors are attached to secondary schools only.

The need for school guidance counsellors in the primary schools is a matter that needs consideration. Various authorities such as Francis (1972), Poole (1972) and Hurlock (1959) indicate that the early years of a child's education are important in that basic attitudes to learning are developed. (37)(38)(39)

Further Behr (1977/1978) states that "Many children fail because of their inability to grasp salient points in lessons. These children can be helped by remediation." (40) Other authorities such as Pringle (1967), Webb (1967) and McClelland (1970) have shown that at least 13% to 16% of pupils in the regular junior primary phase require some form of special help for some part of their early primary schooling. (41)(42)(43)

These facts and the selection for secondary school courses, which begins in the primary school, are adequate justification for the need for guidance counsellors at schools. Before any remedial education programme can be undertaken there is need to identify the problems of children and the areas of scholastic weaknesses. It is in these fields that the assistance of guidance counsellors is of crucial importance.

5.3.3 Appointment of school social workers

The effects of environment on the education of children is only too well known to educationists. Authorities such as Bernstein (1962), Cohen (1965) and Swift (1964) agree to the influence of socio-economic factors on the education of children. (44)(45)(46)

In this investigation it was found that the fathers of many children in the practical course were employed in semi skilled and skilled jobs.

In the light of the above it is suggested that the Department of Indian Affairs employs social workers who could help schools in coping with the problems of the socially disadvantaged child. Such a service will be beneficial not only to the child but also to the parents and teachers.

5.3.4 Educational Objectives

The introduction of differentiated education has resulted in pupils being taught and tested at different levels. Different syllabuses have been introduced for the practical and academic courses as well as for the higher and standard grades in a subject for the senior certificate examination. These factors place an additional demand on teachers. Teachers are required to teach and test at different levels in the secondary schools.

In the light of the above it is recommended that all syllabuses be drawn up with objectives in behavioural terms. The objectives would enable teachers to interpret and teach the content of the syllabus to pupils in the different courses or grades at the desired levels.

5.3.5 Curriculum Study

Curriculum in this context is used to mean the course or subjects offered by the Department of Indian Affairs in its schools. According to Behr (1971) "curriculum study is concerned with the evaluation of syllabuses in respect of their aims, objectives, structure, concepts and methods as sources for learning".⁽⁴⁷⁾ He goes on to state that in, "judging a syllabus cognisance should be taken not only of the specific principles and concepts that pupils are expected to acquire, but also their relevance, and arrangement in sequential and logical order."⁽⁴⁸⁾

In this investigation it is found that the majority of children with above average intelligence are in the academic course, and the majority with average intelligence are in the practical course. It would therefore seem that the teaching methods, examination procedures and syllabuses used in Indian Schools need to be re-assessed. A curriculum study programme designed to assess the syllabuses as well as the examination procedures and teaching methods needs to be undertaken.

5.3.6 Establishment of an education research bureau

Presently research for the Department of Indian Affairs is undertaken by the Education Planners of the Division of Indian Education. Research becomes one of the many functions that the Planners perform. It is the contention of the writer that Departmental research should be undertaken by a research bureau, similar to the one of the Transvaal Education Department. ⁽⁴⁹⁾ The function of the Research Bureau should be to organise and undertake research on all matters concerning the education of the child in this Department. Matters such as curriculum study, measurement and assessment in education and the construction and standardization of scholastic attainment tests could be undertaken by such a bureau. While education planners are able to handle small research projects, a bureau would be able to undertake research into problems in education peculiar to children within the Department.

Research on a National basis, which could affect the education offered to children in the various Education Departments can still be left to the Human Science Research Council which could act as a co-ordinating institute.

REFERENCE

1. VERNON, P.E. : The Measurement of Abilities,
University of London Press, London,
1962 pp. 202-3
2. BEHR, A.L. : A Textbook of Educational Methods,
van Schaik, Pretoria, 1971 pp. 121-128
3. WILLIAMS, J.D. : "Some Problems involved in the
Experimental Comparison of Teaching
Methods", Educational Research,
Vol. 8, No. 1, November 1965 pp. 26-41
4. McCLELLAND, W. : Selection for Secondary Education,
University of London Press, London,
1949 pp. 165-169
5. IBID
6. BRERETON, J.L. : The Case for examinations, University
Press Cambridge, Great Britain,
1944 pp. 93-96
7. HIMMELWEIT, H.T. : Towards a rationalization of examination
procedures, University Quarterly
1969 pp. 21-23
8. PILLINER, A.E.G. : Examinations and Marking cited by
Entwistle, N.J. and Nisbet, J.D. in
Educational Research in Action,
University of London Press, London,
1972 pp. 185-201
9. ENTWISTLE, N.J. AND : Educational Research in Action,
NISBET, J.D. University of London Press, 1972 p. 189
10. IBID
11. TRANSVAAL ONDERWYSBURO : Verslag oor die Matrikulasie-
Eksperiment van die Transvaal
Onderwysdepartement, 1971 pp. 57-58
12. NATAL EDUCATION DEPARTMENT : "Year mark Experiment" Report presented
to the meeting of the Examinations
Board, September 1978 Annexure C.
13. PIDGEON, D.A. AND DODDS, E.M.: "Length of schooling and its effect
on performance in the junior school",
Educational Research, Vol. 3, No. 3,
1961 pp. 214-221

14. ANDERSON, I.H. : "Comparisons of the Reading and Spelling Achievement and Quality of Handwriting of Groups of English", Scottish and American Children cited by Pidgeon, D.A. in Educational Research, Vol. 8, No. 1, November 1965 pp. 3-7
15. POSTLETHWAITE, N. : cited by Pidgeon, D.A. in Educational Research, Vol. 8, No. 1, November 1965 pp. 3-7
16. DALE, R.R. AND GRIFFITH, S. : "Selected Findings from a five-year study of Academic Deteriorators in a Grammar School", Educational Research, Vol. 8, No. 2, February 1966 pp. 146-154
17. IBID
18. SWIFT, D.F. : "Social Class and achievement motivation", Educational Research, Vol. 8, No. 2, February 1966 pp. 83-94
19. WALL, W.D. AND MILLER, K.M. : "Motivation and Counter-Motivation", Child and Education, Vol. 3, 1962 pp. 161-175
20. DOUGLAS, J.W.B. : The Home and School, MacGibbon and Kee, London, 1964 pp. 60-162
21. NAGURAN, C.A. : "A study of Failure in School with special reference to Indian Secondary Education in Natal", Unpublished M.Ed. Thesis, University of Durban-Westville, 1978 pp. 212-215
22. McCLELLAND, W. : op. cit., pp. 237-243
23. NATAL EDUCATION DEPARTMENT : Circular No. 14/1976 No. 59; 59/6, April 1976
24. LANDMAN, W.J.J. : Discussion held with Mr. Landman - Education Planner - Natal Education Department, Pietermaritzburg, on 6 April 1978
25. McCLELLAND, W. : op. cit., p. 216
26. McINTOSH, D.M. : Promotion from Primary to Secondary Education, University of London Press, London, 1949 p. 137

27. VERNON, P.E. : Secondary School Selection, Methuen and Co., London, 1960 pp. 73-95
28. BURT, C. : "Symposium on the Selection of Pupils for Different Types of Secondary Schools". British Journal of Educational Psychology, Vol. 20, February 1950 p.†
29. DEMPSTER, J.J.B. : "Symposium on the Selection of pupils for different types of secondary schools" British Journal of Educational Psychology, Vol. 17, November 1947 pp. 121-133
30. DEPARTMENT OF INDIAN AFFAIRS : File No. I.E. 18
(DIVISION OF EDUCATION)
31. HUMAN SCIENCE RESEARCH COUNCIL : Catalogue of tests, 1976 pp. 48-52
32. DEPARTMENT OF INDIAN AFFAIRS : File No. 19/34/3/1
(DIVISION OF EDUCATION)
33. BEHR, A.L. : A Textbook of Educational Methods, van Schaik, Pretoria, 1977 pp. 140-144
34. FERGUSON, G.A. : Statistical Analysis in Psychology and Education, McGraw Hill, New York, 1966 pp. 265-266
35. DOWNIE, N.M. AND HEATH, R.W. : Basic Statistical Methods, Harper and Row (fourth edition) New York, 1974 p. 69
36. BEHR, A.L. : Methods and Techniques in Educational and Psychological Research, van Schaik, Pretoria, 1973 p. 44
37. FRANCIS, HAZEL : "Sentence Structure and Learning to Read", The British Journal of Educational Psychology, Vol. 42, Part 2, June 1972 pp. †13-†19
38. POOLE, M.E. : "Social Class Difference in Language Predictability", The British Journal of Educational Psychology, Vol. 42, Part 2, June 1972 pp. †27-†36
39. HURLOCK, E.B. : Developmental Psychology McGraw Hill, New York, 1959 p. 229

40. BEHR, A.L. : "The relevance and the nature of the training of teachers in Remedial Education in Initial Teacher Training Courses", Journal of University of Durban-Westville, Vol. 3, No. 1, 1977/1978 pp. 1-7
41. PRINGLE, K.M., BUTLER, N. AND DAVIE, R. : cited by Behr, A.L. in Journal of University of Durban-Westville, Vol. 3, No. 1, 1977/1978
42. WEBB, L. : Children with Special Needs in the Infant School, Collins Fontana Books, London, 1967
43. McCLELLAND, G. : "Children at risk", The Slow Learning Child, University of Queensland, Vol. 17, 1970 pp. 3-7
44. BERNSTEIN, B. : "Social Class, Linguistic Codes and Grammatical Elements", Language and Speech, Vol. 5, 1962 pp. 221-240
45. COHEN, E. : "Parental Factors in Educational Mobility", Sociology of Education, Vol. 38, No. 5, 1965 pp. 404-425
46. SWIFT, D.F. : "Meritocratic and Social Class Selection at Age Eleven", Educational Research, Vol. 8, No. 1, 1965 pp. 65-73
47. BEHR, A.L. : A Textbook of Educational Methods, van Schaik, Pretoria, 1971 pp. 25-26
48. IBID
49. TRANSVAAL EDUCATION DEPARTMENT: "Report of a mission to oversea countries Part 2," Educational Research, April 1975 p. 75

SELECTED BIBLIOGRAPHYBOOKS

1. Banks, Oliver and Finlayson: Interdisciplinary approach to School Achievement, Methuen and Co., London, 1973
2. Behr, A.L.: A Textbook of Educational Methods, van Schaik, Pretoria 1971
3. Behr, A.L. and MacMillan, R.G.: Education in South Africa, van Schaik, Pretoria, 1971
4. Behr, A.L.: Methods and Techniques in Educational and Psychological Research, van Schaik, Pretoria, 1973
5. Behr, A.L.: Psychology and the School, Butterworth, Durban, 1975
6. Behr, A.L.: New Perspectives in South African Education, Butterworth, Durban, 1978
7. Best, J.W.: Research in Education, Prentice-Hall, Unites States, 1959
10. Borg, W.R.: Educational Research - An Introduction, David McKay Company, New York, 1967
11. Brereton, J.L.: The Case for examinations, University Press Cambridge, Great Britain, 1944
12. Brubacker, J.C.: Modern Philosophies of Education, McGraw-Hill, New York, 1962
13. Burt, C.: The Causes and Treatment of Backwardness, University of London Press, England, 1966
14. Clegg, A.B.: Some Problems of Administration in West Riding Grammar Schools, University of Leeds Press, No. 7, 1962
15. Cullen, K.: School and Family - Social Factors in Educational Attainment, Gill and MacMillan, Dublin, 1969
16. Dale, R.R. and Griffith, S.: Down Stream Failure in the Grammar School, Routledge and Kegan Paul, London, 1965
17. Davis, F.B.: Educational Measurement and their Interpretation, Wadsworth, California, 1966
18. Deale, R.N.: Assessment and testing in the Secondary School, Evans Methuens, London, 1976
19. Donlon, T.F.: Measurement and Evaluation, Princeton, New Jersey, 1974

20. Douglas, J.W.B.: The Home and School, MacGibbon and Kee, London, 1964
21. Downie, N.M. and Heath, R.W.: Basic Statistical Methods, Harper and Row, Second Edition, New York, 1965
22. Ebel, R.L.: Measuring Educational Achievement, Prentice Hall, New Jersey, 1965
23. Eggleston, J.F. and Kerr, J.F.: Studies in assessment, English University Press, Great Britain, 1969
24. Entwistle, N.J. and Nisbet, J.D.: Educational Research in Action, University of London Press, London, 1972
25. Eysenck, H.S.: Facts and Fiction in Psychology, Penguin Books, Harmondworth, 1965
26. Ferguson, G.A.: Statistical analysis in Psychology and Education, McGraw-Hill and Co., New York, 1976
27. Glass, D.V.: Social Mobility in Britain, Routledge, London, 1954
28. Good, C.V.: Introduction to Educational Research, Appleton-Century-Crofts, New York, 1963
29. Greene, H.A. and Jorgensen, A.N.: The use and interpretation of High School Tests, Longmans, New York, 1936
30. Greene, H.A., Jorgensen, A.N. and Gerberich, J.R.: Measurement and Evaluation in Secondary School, David McKay, New York, 1974
31. Gulliford, R.: National Foundation for Educational Research in England and Wales, Exploring Education, London, 1969
32. Hurlock, E.B.: Developmental Psychology, McGraw-Hill, New York, 1959
33. Jones, H.E.: Manual of Child Psychology, Chapman and Hall, Second Edition, London, 1954
34. Kerlinger, F.N.: Foundations of Behavioural Research, Holt, Rinehart and Winston, London, 1972
35. Kerr, J.E.: Changing the Curriculum, University of London Press, London, 1968
36. Lindquist, E.F.: Statistical Analysis in Educational Research, Houghton Mifflin, 1940

37. Macintosh, H.G. and Morrison, R.B.: Objective Testing, University of London Press, London, 1969
38. Malherbe, E.G.: Education in South Africa - Vol. 2 (1923-1975), Juta and Co., Cape Town, 1977
39. McClelland, W.: Selection for Secondary Education, University of London Press, London 1949
40. McIntosh, D.M.: Promotion from Primary to Secondary Education, University of London Press, London, 1949
41. Montgomery, R.J.: Examinations, Longmans, Great Britain, 1965
42. Nisbet, J.D. and Entwistle, N.J.: The Age of Transfer to Secondary Education, University of London Press, London, 1966
43. Nuttall, J.K., Blackhouse, J.K. and Willmott, A.S.: Comparability of standards between subjects, Evans Methuens, London, 1974
44. Pidgeon, D.A.: Expectation and Pupil performance, NFER Slough, England, 1970
45. Richmond, W.K.: The School Curriculum, Methuen and Co., London, 1971
46. Ruch, A.M.: The Objective or New Type Examination, Scott Foresman and Co., Chicargo, 1929
47. Schonell, F.J. and Schonell, F.E.: Diagnostic and Attainment Testing, Oliver and Boyd, Edinburgh, 1965
48. Sexton, P.: Education and Income, Viking Books, New York, 1961
49. Gordon, I.J.(ed): Readings in Research in Developmental Psychology, Scott Foresman and Company, London, 1971
50. Stalnaker, J.M.: Educational Measurement, American Council on Education, Washington D.C., 1951
51. Taba, H.: Curriculum Development, Theory and Practice, Harcourt, Brace and World Inc., New York, 1962
52. Fawney, D.: Schools Councils Research Studies, Macmillan, London, 1976
53. Valentine, C.W.: The mark of Examiners - Reliability of Examination, Methuen, London, 1938

54. Vernon, P.E.: The Measurement of abilities, (Rev. Ed.) University of London Press, London, 1958
55. Vernon, P.E.: Secondary School Selection, Methuen and Co., London, 1960
56. Webb, L.: Children with Special needs in the Infant School, Collins Fontana Books, London, 1967
57. Wheeler, D.K.: Curriculum Process, University of London Press, London, 1967
58. Williams, I.C. and Boreham, N.C.: The Predictive value of CSE grades for further education, Evans Methuens, London, 1972

JOURNALS

59. American Journal of Orthopsychiatry, vol. 25, 1955
60. American Psychologists, Vol. 5, 1950
61. British Journal of Educational Psychology, Vol. 17, 1947
62. British Journal of Educational Psychology, Vol. 19, 1949
63. British Journal of Educational Psychology, Vol. 20, 1950
64. British Journal of Educational Psychology, Vol. 23-24, 1953-1954
65. British Journal of Educational Psychology, Vol. 36, Part 3, 1966
66. British Journal of Educational Psychology, Vol. 42, Part 2, 1972
67. Child and Education, Vol. 3, 1962
68. Educational Research, Vol. 3, No. 3, 1961
69. Educational Research, Vol. 8, No. 1, November 1965
70. Educational Research, Vol. 8, No. 2, February 1966
71. Educational Research, Vol. 19, No. 2, 1968
72. Educational Research, Vol. 11, No. 3, 1969
73. Educational Review, Vol. 26, No. 2, January 1974
74. Fiat Lux, Vol. 7, No. 7, September 1972
75. Fiat Lux, Vol. 7, No. 9, November 1972

76. Fiat Lux, Vol. 7, No. 10, December 1972
77. Fiat Lux, Vol. 13, No. 8, October 1978
78. Free State Educational News, No. 12, 1974
79. International Review of Education, Vol. 19, 1973
80. Journal of Curriculum Studies, Vol. 1, No. 2, May 1969
81. Journal of Educational Research, Vol. 16, No. 2, 1965
82. Journal of Educational Psychology, Vol. 21, January 1930
83. Journal of the University of Durban-Westville, Vol. 1, No. 2, 1972
84. Journal of the University of Durban-Westville, Vol. 3, No. 1, 1977/1978
85. Language and Speech, Vol. 5, 1962
86. Mentor, October 1978
87. Scottish Educational Journal, Vol. 58, No. 14, April 1975
88. School Review, Vol. 20, September 1912
89. Sociology of Education, Vol. 38, No. 5, 1965
90. The British Journal of Educational Studies, Vol. 21, No. 3, October 1973
91. The Education Digest, Vol. 40, No. 5, January 1975
92. The Education Digest, Vol. 28, December 1962
93. The Journal of Educational Research, Vol. 61, No. 8, April 1968
94. The Journal of Educational Research, Vol. 61, No. 4, December 1967
95. The Journal of Social Psychology, Vol. 70, 1966
96. The Transvaal Education News, Vol. 74, No. 8, August 1977
97. The Slow Learning Child - University of Queensland, Vol. 17, 1970
98. Transvaal Education Department - Education Bulletin, Vol. 7, No. 2 June 1962
99. Transvaal Education Department - Education Bulletin, Vol. 7, No. 2 June 1967

100. Transvaal Education Department - Education Bulletin, Vol. 13, No. 3, September 1968

REPORTS

101. Department of Economics, University of Natal: "The Indian Domestic Budget", Additional Report No. 6 of Natal Regional Survey - Kwartlants, Durban, 1969
102. Guilford, J.P. and Hoepfner, R.: Report from Psychological Laboratory, University of Southern California, No. 30, 1963
103. Transvaal Education Department: Interdepartementele Advieskomitee Insake Differensiasie, Kurrikulum en Voorligting vir die Sekondêre skool, 1972
104. Transvaal Education Department: Report of a mission to oversea countries Part 2 Educational Research, April 1975
105. Transvaal Onderwysburo: Verslag oor die Matrikulasie - Eksperiment van die Transvaalse Onderwysdepartement, 1971

PAPERS PRESENTED AT CONFERENCES

106. Behr, A.L.: Meeting the needs of the underachieving child in South Africa: An Analysis of current resources and needs: Address delivered at the National Conference on the Underachieving child - University of Durban-Westville, Durban, 1974
107. Coulter, M.A.: "Objective Tests - Problems and Practice", Paper presented at the National Conference on Evaluation, Johannesburg, July 1974
108. Craig, J.K.: "Internal Assessment in Secondary Schools with special reference to certain overseas country", Paper presented at the National Conference on Evaluation, Johannesburg, July 1974
109. Ebel, R.L.: "Knowledge Versus Ability in Achievement Testing", Paper presented at the National Conferende on Evaluation, Johannesburg, July 1974
110. Ebel, R.L.: "The Concept of Evaluation", Paper presented at the National Conference on Evaluation, Johannesburg, 1974

111. Jooste, J.H.: "Assessment in Differentiated Education", Paper presented at the National Conference on Evaluation, Johannesburg, July 1974
112. Loret, P.G.: "Implementing, Evaluating, and using a statewide assessment program", Paper presented at the annual meeting of the national council on measurement in education, Washington D.C., March 1975
113. Schofield, H.: "The Educative use of Evaluation in the Primary School", Paper presented at the National Conference on Evaluation, Johannesburg, July 1974, p. 1
114. Strobel, M.G. and Dudek, S.Z.: "On the Testing of Tests", Paper presented at the Annual Convention of the American Psychological Association, New Orleans, Louisiana, 1974

OTHER PUBLISHED SOURCES

115. Human Science Research Council: Catalogue of Tests (1976), Pretoria, 1976
116. The Joint Matriculation Board: Matriculation Examination Handbook, 1978
117. Republic of South Africa: Government Gazette, Vol. 77, No. 3306 of 12:11:1971

SOURCES FROM EDUCATION DEPARTMENTS

118. Department of Indian Affairs - (Division of Education): Circular No. 11 of 1971, File No. 19/20/6/1
119. Department of Indian Affairs - (Division of Education): Circular No. 28 of 1972, File No. 19/15/6/2
120. Department of Indian Affairs - (Division of Education): Circular No. 31 of 1972, File No. 19/15/6/2
121. Department of Indian Affairs - (Division of Education): Circular No. 39 of 1973, File No. 19/16/4
122. Department of Indian Affairs - (Division of Education): Circular No. 49 of 1975, File No. 19/20/14/2

123. Department of Indian Affairs - (Division of Education):
Circular I.E. No. N of 1975, File No. 19/15/7/4/11
124. Department of Indian Affairs - (Division of Education):
Circular No. 4 of 1977, File No. 9/34/1/16
125. Department of Indian Affairs - (Division of Education):
Circular No. 24 of 1977, File 19/15/6/2
126. Department of Indian Affairs - (Division of Education):
Circular Minute AY of 1977, File No. 1/6/2/1
127. Department of Indian Affairs - (Division of Education):
Circular No. 39 of 1978, File No. 9/34/1/17
128. Department of Indian Affairs - (Division of Education):
Circular I.E. No. AB of 1978, File No. 19/20/6/1
129. Department of Indian Affairs - (Division of Education):
File No. 1/9/23
130. Department of Indian Affairs - (Division of Education):
File No. 19/43/2
131. Department of Indian Affairs - (Division of Education):
File No. 19/20/6/2
132. Department of Indian Affairs - (Division of Education):
Statistics File No. 19/46/2
133. Department of Indian Affairs - (Division of Education):
Psychological Service File No. 19/34/6/3
134. Department of Indian Affairs - (Division of Education):
File No. 19/34/2
135. Department of Indian Affairs - (Division of Education):
Research File No. 19/34/3/2
136. Department of Indian Affairs - (Division of Education):
File No. 19/34/3/1
137. Department of Indian Affairs - (Division of Education):
File No. I.E. 18
138. Department of Indian Affairs - (Division of Education):
Handbook to Principals - 1978
139. Department of Indian Affairs - (Division of Education):
Minutes of the 18th Examination's Board Meeting
held in Durban on Friday 8 October 1977

140. The Joint Matriculation Board: Minutes of Meeting held in Pretoria on Tuesday 13 January 1976
141. Landman, W.J.J.: Interview held with Mr. Landaman - Education Planner - Natal Education Department, Pietermaritzburg, 6 October 1978
142. Natal Education Department: Circular No. 14/1976 No. 59; 59/6, April 1976
143. Natal Education Department: "Year mark Experiment"
Report presented to the Meeting of the Examination's Board,
September 1978 Annexure C
144. Transvaal Onderwysburo: Verslag oor die Matrikulasie-Eksperiment van die Transvaal Onderwysdepartement, 1971 pp. 57-58

DEPARTMENT OF INDIAN AFFAIRS

DIVISION OF EDUCATION

SYLLABUS

FOR

ENGLISH ACADEMIC COURSE

STANDARDS 5, 6 AND 7

DEPARTMENT OF INDIAN AFFAIRSDIVISION OF EDUCATIONSYLLABUS FORENGLISH HIGHER GRADESTANDARDS 5, 6 AND 7

NOTE: This core syllabus covers the work to be done in English Higher during the Junior Secondary phase. All sections of the work must be dealt with in each standard.
See "GENERAL".

General Aims

1. To promote the pupil's ability to communicate in English confidently and effectively;
2. to promote the pupil's intellectual, emotional and social development;
3. to extend his ability to observe, to discriminate and to order his thoughts coherently;
4. to help him to understand himself and others so that he may live more fully, happily and responsibly.

These general aims may be regarded as an end of education, almost all subjects in the curriculum being directed towards fulfilling them.

The relationship between a child's linguistic skill and his personal development is a unique one. The teacher of English contributes to a process that begins in infancy and continues throughout life. This work is not to be thought of merely as a series of unrelated classroom exercises; it is rather the creating of opportunities for the extension and enrichment of experience.

It is essential to bear in mind that spoken and written communication should be purposefully motivated. The pupil must not only know the reason for communicating but also have something to communicate.

The three divisions in the syllabus may be regarded as the areas in which the general aims can be promoted. Methods which conflict with the general aims should not be used. At all levels and in all areas of the work, enjoyment and fulfilment must be the aim.

The syllabus

For convenience, the syllabus is presented under three headings although in practice the work must be integrated. Each section which follows must receive regular attention.

A. Spoken English

(a) Aims:

1. to train the pupil to listen and to speak courteously;
2. to develop in him a readiness and an ability to consider new ideas and other points of view;
3. to teach him to speak fluently, clearly and with ease in order that he may acquire poise and confidence;
4. to develop in him the ability to convey his observations and thoughts in an orderly and convincing manner.

(b) Oral activity includes

1. conversation;
(It is important to remember that spontaneous and incidental conversation is a profitable language activity).
2. activities to stimulate the imagination;
3. discussion of topics of local, general and personal interest and significance;
4. discussion, with demonstration, of personal interests and hobbies;
5. discussions arising from prescribed and other reading;
6. discussion of topics based on other parts of the pupil's course of study;
7. short talks on a variety of topics (of interest and use to the pupil) together with questioning and discussion;
8. the reading aloud of prose and poetry;
9. dramatic activities;
10. exercise in listening-comprehension involving recall, span of attention and a sensitive and perceptive response to tone, style, feeling and intention;

11. training in critical and selective listening.

- N.B. (1) All the above should, as far as possible, be group activity in order that as many pupils as possible may take part. The training of pupils in group techniques is essential.
- (2) Pupils should be made aware of the social aspects and functions of spoken English. Pupils should be led to see that some ways of speaking and/or word usage are more acceptable than others according to circumstances.

B. Reading

(a) Aims:

1. To take cognisance of levels of reading and to cater for them;
2. to continue developing the pupil's skill and technique in reading;
3. to develop study skills e.g. skimming, cursory and intensive reading, reviewing what has been read, research work in the library and the use of books of reference, discouraging mere transcription;
4. to encourage reading for enjoyment;
5. to encourage reading for information;
6. to introduce the pupil to some critical study of literature suitable to his stage of development.

(b) Activities:

1. In addition to the books dealt with in the reading programme (See (c) "The study of literature"), supplementary reading material of all kinds should be provided for the pupil to read for his cultural and social advancement.
2. Considerable attention should be given to the reading aloud and the discussion of poetry and prose.
Few activities can be more valuable or stimulating than the skilful reading aloud by the teacher from the works that he and/or the pupils enjoy.

Teachers are urged to avail themselves of the many excellent recordings now available.

3. Emphasis on interpretation and understanding should characterise all reading activities other than those whose aim is purely enjoyment. In addition, comprehension exercises may be used to stress the need for accuracy in silent reading, and to reveal the degree of understanding of what has been read. As pupils mature, questions should be directed less at literal facts and more at implied meaning, tone and inference.

(c) The study of literature

A reading programme must be followed. In addition to being guided through this programme, the pupil should be encouraged to read at the highest level at which he can respond with enthusiasm and sincerity and above all with understanding and enjoyment.

C. Written English

(a) Aims:

1. To train the pupil to record, in a clear, correct and orderly manner, what he thinks, observes and knows;
2. to teach him how to organise his thoughts and extend his thinking;
3. to provide stimuli which will lead to the writing of imaginative prose and/or poetry.

(b) Written activity includes

1. the writing of narratives and short stories;
2. descriptive writing;
3. practice in factual communication through the writing of diaries, reports, instructions and summaries;
4. the writing of dialogue and playlets;
5. the training of the pupil to fill in forms and questionnaires;
6. the writing of formal and informal letters.

Note: (1) Written English should be in a form appropriate to the topic, to the writer's intention and to the kind of reader he has in mind.

- (2) Literature and/or topics of general interest and immediate significance can provide stimuli for the pupil's writing.

- (3) The pupil should be encouraged to read aloud and evaluate what he and his fellow pupils have written.

NOTE: Language Study

A study of language in action should form an integral part of English teaching to the end that the pupil may speak and write more effectively and appreciate literature more fully.

Guidance and instruction in sound English usage and sentence structure should be related to written and spoken activity in English. They should be related, where necessary, to the pupil's needs as revealed in his actual writing and speaking. They should include

1. punctuation and spelling;
2. a knowledge of the following terms and their functions - noun, pronoun, adjective, adverb, verb, preposition and conjunction. (No sub-categories of these are required.)
3. vocabulary study, idiomatic expression and simple figurative language;
4. tenses, sequence of tenses, concord;
5. direct and reported speech;
6. sentence and paragraph construction; (Emphasis should be on synthesis rather than on analysis.)
7. correct English usage;
8. the objective and subjective use of language, e.g. the distinction between fact and opinion; discrimination between the sincere and the insidious.

Much of the study of the way in which language works can be carried out orally. It should not be undertaken or examined out of context, that is, through a series of detached, isolated exercises or questions. The pupil should become acquainted with the commoner forms of grammatical terminology and accidents only in so far as they are relevant to the discussion of his work. In this way these features will be considered as part of the living language and not as dead exhibits.

General

While the syllabus must be approached with a depth and a breadth appropriate to Standards 5, 6 and 7 progressively, special mention must be made of the work done in Standard 7.

This standard marks the end of the Junior Secondary phase of the pupil's education and so the approach to the subject must approximate to some degree to that found in the syllabus for Standards 8, 9 and 10. This applies particularly to the study of literature.

DEPARTMENT OF INDIAN AFFAIRS

DIVISION OF EDUCATION

SYLLABUS

FOR

• MATHEMATICS ACADEMIC COURSE

STANDARDS 5, 6 AND 7

DEPARTMENT OF INDIAN AFFAIRS
DIVISION OF EDUCATION
SYLLABUS FOR MATHEMATICS FOR STDS. V - VII

1. AIMS

- 1.1 To give the pupil a clear insight into, and a thorough knowledge and understanding of those basic mathematical principles which will prepare and equip him for further study in mathematics and other subjects.
- 1.2 To develop the ability of the pupil to use mathematical knowledge and methods to solve problems including those which he may encounter also in other subjects or which may arise in his daily life.
- 1.3 To contribute to the general education of the pupil with special emphasis on the development of logical thought, of neat, accurate and systematic methods of working and critical evaluation of his own work.
- 1.4 To arouse in the pupil a love for mathematics and an interest in the further study of mathematics and related subjects.

2. GENERAL REMARKS

- 2.1 Forming of concepts remains the main aim of the tuition. Accuracy, neatness and speed should nevertheless receive the necessary attention.
- 2.2 Pupils must be trained in the habit of estimating answers and where applicable of testing answers.
- 2.3 Unnecessarily complicated manipulations must be avoided. Applications must be meaningful.

- 2.4 Sufficient oral work must precede written work.
- 2.5 Illustrations and graphical representations must be used wherever applicable.
- 2.6 Skill in the handling of numbers must be emphasized.
- 2.7 The arrangement of the content of the syllabus and its subdivisions is not necessarily an indication of the sequence in which the work must be handled. Wherever possible, different sections should be integrated.
- 2.8 Situations within the everyday experience of the pupils should, where possible, be used as a starting point in the learning of new principles.
- 2.9 Self-activity, where applicable, should be encouraged.
- 2.10 In these syllabuses the set of natural numbers is 1; 2; 3; ... and the set of counting numbers is 0; 1; 2;

3. SYLLABUS FOR STANDARD V

3.1 Consolidation of:

3.1.1 Knowledge of and the meanings of: odd, even, sum, difference, minuend, subtrahend, multiplicand, multiplier, product, dividend, divisor, quotient, remainder, factor, multiple, common factor, common multiple, exponent, power.

3.1.2 Practice in the following:

3.1.2.1 Number combinations and tables previously dealt with

3.1.2.2 The four operations applied to natural numbers, ordinary fractions and decimal fractions.

3.2 Sets

3.2.1 Determining the elements which belong to one or the other or to both of two given sets

3.2.2 Language and notation:

3.2.3 Well-known sets e.g. the sets of natural numbers, even numbers, odd numbers, prime numbers and the relation between these sets.

3.3 Graphical representations

(Graphs should be looked upon as a unifying concept and hence graphical representations must be used throughout the syllabus wherever applicable and suitable.)

3.3.1 Simple graphs of statistics

3.3.2 Discussion of, interpretation of, and deductions from graphs already drawn

3.3.3 Graphical representation of the relationship between two variables on two rectangular axes limited to counting numbers.

3.4 Natural numbers and counting numbers

3.4.1 Place value

3.4.2 Analysis of numbers to show the decimal grouping

3.4.3 Relative magnitude (order) of numbers and their positions on the number line, order being indicated by the symbols and

3.4.4 Rounding off of numbers

3.4.5 The four operations with emphasis on the basic properties; order of operations

3.4.6 Properties of zero and one

3.5 Vulgar fractions

3.5.1 Concept of magnitude and notations

3.5.1.1 Practical acquaintance with fractions
most general used in practice

3.5.1.2 The function of numerator and denominator

3.5.1.3 Order and magnitude of proper and im-
proper fractions also written as mixed
numerals) indicated by the relationship
signs =, =, ,
Representation on a number line.

3.5.2 Equivalent fractions

3.5.2.1 Visual representation to form the concept

3.5.2.2 Application of the property $a \times 1 = a$
, in the formation of equivalent fractions

3.5.2.3 Application of the principle of a common
multiple to find a common denominator.

3.5.3 Operations (proper and improper fractions
and mixed numerals)

3.5.3.1 The four operations

N.B. Examples limited to types containing
at most two operational symbols

3.5.3.2 Calculation of fractional parts of given
quantities

3.5.3.3 Expression in its simplest form of one
quantity as a fraction of another.

3.6 Decimal fractions

3.6.1 Notation and concept of magnitude (order)

3.6.2 Place value

3.6.3 Writing and recognition of vulgar fractions
as decimal fractions (limited to simple
examples)

- 3.6.4 Conversion of decimal fractions to vulgar fractions and conversely
- 3.6.5 Notation for recurring decimals
(Only simple cases)
- 3.6.6 The four operations with special emphasis on place value and basic properties
- 3.6.7 Approximating correct to the nearest whole number and to three, two or one place(s) after the decimal sign
- 3.7 Percentages
 - 3.7.1 Concept, notation and graphical representation
 - 3.7.2 Equivalence of vulgar fractions, decimal fractions and percentages; conversion from one form of notation to the others
 - 3.7.3 Calculation of a percentage of a given quantity
 - 3.7.4 Expression of one quantity as a percentage of another
 - 3.7.5 Use of percentages for the purpose of comparisons and simple applications
- 3.8 Ratio and proportion
 - 3.8.1 Ratio
 - 3.8.1.1 The concept of ratio
 - 3.8.1.2 Practical and graphical representation of ratios
 - 3.8.1.3 Easy examples with respect to the division of a quantity in a given ratio
 - 3.8.2 Proportion (Direct proportion only)
 - 3.8.2.1 The concept of proportion



- 3.8.2.2 Easy examples to determine one unknown term in a proportion
- 3.8.2.3 Practical examples of the application of the concept of proportion
- 3.9 Averages
 - 3.9.1 The meaning of average
 - 3.9.2 Calculation of an average
- 3.10 Denominate numbers and physical quantities
 - 3.10.1 Calculations with respect to money, time, length capacity (liquid), and mass applied to practical tasks related to the environment and range of interests of the pupils. (Calculations limited to: Rand, cent; year month, week, day, hour, minute, second, km, m, mm, kl, l, ml; metric ton, kg, g)
 - 3.10.2 The Metric System
 - 3.10.2.1 General discussion of the structure of SI and the meaning and use of prefixes (kilo - to milli-)
 - 3.10.2.2 Particular discussion of those units which are most important in mathematics
 - 3.10.3 Units of area
 - 3.10.3.1 Knowledge of the following units of area: m^2 , mm^2 , cm^2
 - 3.10.3.2 Acquaintance with hectare (ha) and km^2
 - 3.10.4 Units of volume
 - 3.10.4.1 Knowledge of the following units of volume: m^3 , cm^3
- 3.11 Geometric concepts

(The approach to this work should be practical, and the correct use of mathematical instruments should be stressed. Practical work by means of drawing, paper folding, cutting out, graphical work and the use of line and rotational symmetry to discover the properties of plane figures and to develop the concepts of shape, perimeter and area should precede calculations.)

3.11.1 Perimeter

3.11.1.1 Perimeters of triangles and quadrilaterals

3.11.1.2 Simple applications

3.11.2 Area

3.11.2.1 Experimental development of the concept

3.11.2.2 Calculation of the area of rectangular figures

3.11.2.3 Simple applications

3.11.3 Volume

3.11.3.1 Experimental development of the concept

3.11.3.2 Calculation of the volume of rectangular prisms

3.11.4 Points and lines

3.11.4.1 Practical acquaintance with the concepts: point, line, line segment, horizontal, vertical, perpendicular and parallel lines (no definitions)

3.11.5 Angles

3.11.5.1 Concept of an angle

3.11.5.2 Measuring and constructing angles up to 180° using a protractor

3.11.5.3 Kinds of angles: right angle, straight angle, rotation, acute angle, obtuse angle, reflex angle

- 3.11.5.4 Points on a compass: the eight main directions
- 3.11.6 Rectangles, squares and triangles
 - 3.11.6.1 Kinds of triangles: acute-angled, obtuse-angled, right-angles, isosceles and equilateral
 - 3.11.6.2 Practical determination of the properties of rectangles, squares and triangles
- 3.11.7 The circle
 - 3.11.7.1 Construction of circles using a pair of compasses
 - 3.11.7.2 Determining the ratio of the diameter or of the radius to the circumference of a circle
- 3.11.8 Drawing
 - 3.11.8.1 Simple drawing to scale incorporating squares, rectangles and right-angled triangles
 - 3.11.8.2 Simple drawings in which a pair of compasses, set squares, protractor and the ruler are used.
- 3.12 Number concept
 - 3.12.1 Consolidation and extension with respect to
 - 3.12.1.1 the properties of the set of natural numbers; closure
 - 3.12.1.2 the properties of the set of counting numbers; operations with zero
 - 3.12.1.3 the properties of the set of positive rational numbers and zero, i.e. counting numbers and fractions
 - 3.12.2 Number sentences

DEPARTMENT OF INDIAN AFFAIRS

DIVISION OF EDUCATION

ENGLISH PAPER

STANDARD FIVE

TIME: 1 hrs

MAX. MARKS: 100

NAME: _____

=====

SECTION A: COMPREHENSION

Read the following passage carefully and then answer the questions that follow.

TROPICAL RAIN FORESTS

Tropical rain forests may not seem like pleasant places to live in, but people make their homes in some parts or all of them. Some of these people are seen as seldom as the animals and the birds that live in the treetops. As silently as the jaguar or puma, they move through the forests. In the forest of Africa, America, or Asia, people live in much the same way. From the forests they get their houses, their food, and clothes they wear. Yet these people present many contrasts - in their looks and their lives, in the languages they speak and the customs they follow.

Many different Indian tribes live in the Amazon rain forest. Some are savages who kill their enemies with spears and darts tipped with poison. Some are head-hunters who shrink the heads of their victims. But more of them are people who live in peace with men of other tribes and races.

Some forest dwellers are hunters, who bring down their game with bows and arrows or long blowguns. From the streams they get fish; from the forest they gather berries, nuts, and fruit. These are the nomads of the forest, moving from one campfire to another. They build no home except rude shelters of branches and leaves. They do not farm or work for others. The Negritos, or pygmies, living deep within the forests of Asia and Africa, are examples of such hunters. White men seldom catch more than a glimpse of these tiny brown-skinned tousled-haired men, for they are as shy as the most timid animals.

QUESTIONS:

1. Why do you think the people moved through the forest silently?

.....

2. In which way do the people of the forests of Asia, America and Africa differ, even though they live in very much the same way?

.....

3. Why is the dart of an Amazon savage very deadly?
4. With which animal's movement is the movement of the forest dwellers compared? Why?
5. What do the head-hunters do to their victims?
6. How do the hunters kill their game?
7. Why are the forest dwellers referred to as "nomads"? ...
8. Which tribe lives deep within the forests of Africa? ...
9. Why do Whites seldom catch a glimpse of the pygmies? ...
10. Why do you think the nomads made rude shelters of branches and leaves?

(10)

SECTION B: LANGUAGE

1. Underline the word which does not fit in with the others

Example: small little quiet tiny

- | | | | |
|------------|---------|-----------|------------------|
| a. started | set-off | departed | returned |
| b. simple | easy | hard | straight-forward |
| c. reveal | hide | bury | cover |
| d. perfect | good | faultless | rough |
| e. quietly | quickly | gently | slowly |

(5)

2. Use one word of the same meaning in place of the words underlined.

Example: The flower-seller is late. florist

- a. My father's brother is coming to see us. _____
- b. The girl went out without a hat. _____
- c. Those people are well to do. _____
- d. The farmer sold three young cows. _____
- e. He is not well. _____

(5)

3. Write the Plurals of:

- | | | | |
|-------------|-------|-------------------|-------|
| a. tooth | _____ | b. mouse | _____ |
| c. spoonful | _____ | d. sheep | _____ |
| e. knife, | _____ | f. turkey | _____ |
| g. mosquito | _____ | h. brother-in-law | _____ |
| i. woman | _____ | | |
| j. piano | _____ | | |

(5)

4. Use a Collective Noun to complete the following sentence

Example: The fisherman netted a Shoal of sardines.

- a. A large _____ of cattle grazes in the field.
- b. Our country has a small _____ of ships.
- c. Twelve eggs make a _____ .
- d. A _____ of bees entered the garden.
- e. John has a _____ of stamps.

(5)

5. Use the Correct form of the word shown in brackets:

- a. His (absent) _____ caused great (anxious) _____
- b. The bird preferred (free) _____ to (capture) _____
- c. Jack asked (permit) _____ to go home early.

(5)

6. Write the correct form of the word in brackets in each sentence:

EXAMPLE: The cat belongs to (we). us

- a. Please help (I). _____
- b. The teacher helped (we). _____
- c. This is (me) pencil . _____
- d. (We) car has come. _____
- e. I saw (they). _____
- f. The hat belongs to (she). _____
- g. The children miss (they) mother. _____
- h. This book is (my). _____
- i. This is a secret between you and (I) _____
- j. He has a friend with (he). _____

(5)

7. Write out the underlined phrase only using the Apostrophe:

Example: She wore the uniform of the nurse. nurse's unifo

- a. I borrowed the book of the girl. _____
- b. This is the pen of James. _____
- c. The shop deals in clothes of men. _____
- d. I went to the firm of Ravi and Kuben. _____
- e. The wheels of the wagon sank. _____

(5)

8. Give the word Opposite in meaning to the underlined word

- a. The right (_____) key was lost (_____).
- b. If you add (_____) two letters it will make sense (_____).
- c. Arms are necessary (_____) in times of war (_____).
- d. We took a public (_____) road to safety (_____)
- e. A proud (_____) girl is despised (_____) by all.

(5)

9. Give the correct form of the Adjective within brackets:

Example: Ronny is the (good) member of our club. best

- a. My share is (little) than Tom's. _____
- b. No man is (generous) than he. _____
- c. Saras is the (young) of the twins. _____
- d. He is the (bad) of the two. _____
- e. This is the (fat) kitten in the litter. _____

(5)

10. Give the correct form of the Verb within brackets:

Example: The boy (play) football yesterday. played

- a. The sun (shine) brightly yesterday. _____
- b. He had (see) her yesterday. _____
- c. The door closed and he (go). _____
- d. I have (sing) many a song. _____
- e. A stitch in time will save it from being (tear). _____

(5)

11. Fill in the correct Prepositions:

Example: I went to call him.

- a. My rival walked away _____ me in the match.
- b. The thief ran _____ the bathroom.
- c. This book is different _____ that.
- d. I agree _____ you.
- e. The girl slipped _____ a banana peel. (5)

12. Form Adjectives from the following:

Example: honour honourable

- a. pain _____
- b. health _____
- c. friend _____

Form nouns from:

Example: sad sadness

- a. depart _____
- b. strong _____

(5)

SECTION C : COMPOSITION (20)

Write a composition of about 20 to 25 lines on any ONE of the following topics:

1. TELEVISION: Why I like or dislike it.
2. MY AMBITION: Say what you are doing and what you plan to do to fulfil your ambition.
3. FUND-RAISING: Your class has decided to raise funds for the COMMUNITY CHEST. Say how they did this.

SECTION D: LETTER (10)

Write a letter to the Manager, New Era Booksellers, P.O. Box 327, Pietermaritzburg, 3200, complaining about the condition in which you received, by post, the copy of History Through the Ages by F. Smith.

DEPARTMENT OF INDIAN AFFAIRSDIVISION OF EDUCATIONENGLISH PAPERSTANDARD SIXTIME: 1 HOURMAX. MARKS: 100

A. COMPREHENSION (50)

Study the following passage and then answer the questions upon it in your own words and in full sentences.

I suppose we had been in bed for an hour or so when I woke up to find the tent weirdly illuminated. As always, when in camp, we slept with the tent wide open to the night, and I saw the trees outside the tent, the camp table and our chairs dancing in the lurid (terrible) glare of fiery light. I got up and went outside.

Terrifyingly close I saw a wall of flame rapidly approaching. I could hear the roar and crackle of the fire. The bursting of bamboos sounded like gun-fire. Thanking heaven that we were close to the river, I hurried back and woke my husband.

In a few seconds the whole camp was awake. The fire was dangerously near. Not, my husband assured me, that the camp was in real danger. The flames would retreat when they reached the fire-line where there was nothing for them to consume. But, apart from the possibility of falling sparks, the danger was that our elephants might take fright and bolt. Their front legs were shackled to prevent them wandering too far from the camp, but they were untethered, free to move about browsing through the night - as is the way of elephants, who are nocturnal feeders. The smell of fire would be enough to frighten them into panic. Already we could hear their restless movements, their squealing and their trumpeting. If they bolted (shackled though they were they could shuffle speedily under the spur of fright) Heaven alone knew when we might find them again.

Moreover, it was possible that they might charge the camp, trampling everything ourselves included, to pieces in their panic.

1. What discovery did the writer make when she wakened?
2. Describe the sight which met her eyes as she gazed through the open tent. (1)
3. Describe the fire as it came nearer the camp. (1)
4. What did the writer hear? (1)
5. For what was the writer particularly thankful? (1)
6. How long did it take before the whole camp was awake

7. After the realization of danger had come to the writer what did she do? (1)
8. How did her husband reassure her? (1)
9. What is a "fire-line"? (1)
10. What two things did the writer fear particularly? (1)
11. When did the elephants feed? What word provides the answer? (2)
12. What might cause the elephants to panic (1)
13. Choose a word from the passage which means:-
 unchained -
 coming near -
 quickly -
 chained -
 go back -
 scare - (3)
14. Say whether the following statements are TRUE or FALSE
 a. The writer awoke to find the camp on fire.
 b. The writer's husband feared that the camp would be destroyed.
 c. The elephants fled when they smelt the fire.
 d. The elephants were free to roam about. (4)
15. Give the part of speech of:-
 I - weirdly -
 fiery - assured -
 feeders - panic - (3)
16. Change the following sentences to the passive voice
 a. The smell of the fire would frighten them.
 b. She saw the trees outside the tent. (2)
- (25)
- B. LANGUAGE (4)
1. Punctuate the following:
 mother said he i love the princess ronda very much
 and you must ask the king to let me marry her (7)

2. Fill in the apostrophe:

- a. My eldest uncles friends visited us.
- b. The childrens dog was lost.
- c. Thats his book.
- d. They left at ten o clock.
- e. The butchers isnt far away.
- f. The two boys bicycles were stolen.
- g. Ranjans books were lost (8)

3. Underline the correct word in each sentence.

- a. Prince Charles is the (heir, hare, hair) to the British throne.
- b. Why (were, where) you late?
- c. (Their, there) are five in the family.
- d. The building was three (storeys, stories) high.
- e. Neither Heera nor Shan (is, are) coming. (2)

4. Correct the following sentences:

- a. Has I walked home I seen the man.
- b. Siva went home because why he was ill.
- c. There is many beaches in Natal
- d. I no why you did it.
- e. I said him the truth.
- f. He has been truanting.
- g. He broke one of the vase
- h. You must not play fools with him.
- i. The principle of the school punished the boy.
- j. The ship sailed up the river which later caught fi
- k. Raj keeps a green parrot in a cage that can talk.
- l. She wear a pretty hat.
- m. I feel ill yesterday. (15)

5. Fill in the correct preposition.

- a. She is proud her looks.
- b. He died cancer.
- c. He fell the chair.
- d. That cloth is inferior quality.
- e. The faulty brake were responsible the accident (2)

6. Combine the following sentences into a single sentence

- a. John is not ill. Mary is not ill.
- b. The cow is in the paddock. The calves are with he
- c. I was not at home at 5 o' clock. The guest arrive then.
- d. I know Worcester. I lived there for a time.
- e. I was tired. I continued working. (2)

7. Supply the correct form of the word in brackets.

- a. The (soon) you go, the (good).
- b. The patient is getting (bad) from day to day.
- c. Mary is the (beautiful) girl in the town.
- d. Have you (buy) that farm? (2)

SECTION C

Write a composition of about 30 lines on one of the following topics:-

- (a) My favourite radio or television programme.
- (b) The person who has been my inspiration in life.
- (c) A spy episode.

(20)

SECTION D

Write a letter to your uncle, asking for permission for a party of five to camp on his farm for a week during the holidays. Give a brief description of what they intend to do during their stay.

(15)

DEPARTMENT OF INDIAN AFFAIRS
DIVISION OF EDUCATION
ENGLISH PAPER
STANDARD SEVEN

TIME: 1½ hours

MARKS: 100

=====

SECTION A

Write a composition of about 35 lines on one of the following topics:-

- a. The proudest moment of my life.
- b. My lively class friends.
- c. The value of sporting activities in school.

SECTION B

Write the following letter:-

You wish to apply for a part-time job during the holidays. Write to A.J. JOOSUB & COMPANY, 150 GREY STREET, DURBAN, 4000, and apply for the position of temporary shop assista

(20)

SECTION C - LANGUAGE

1. Correct the following sentences:-

- a. Between you and I, he did not know where to go.
- b. The boy came today who is your friend.
- c. Running down the main street his hat flew off.
- d. Who was Jane speaking to when you passed her.
- e. Each of the girls chooses their own book. (5)

2. Join these sentences to form one complex sentence.

The milk boiled over. We all raced for the kitchen.
 The floor had just been washed. (5)

3. Fill in the correct preposition.

- a. The railways cater the travelling public.
- b. The naughty boy is not worthy praise.
- c. You must abstain smoking.
- d. The visitor was stung..... his host's rude rema
- e. We do not agree..... him.

4. Give the parts of speech of the words underlined.

- a. Leaky taps waste water.
- b. The factory burns its waste products.
- c. The waste of water may result in serious shortage.
- d. Always rest after a hearty meal.
- e. The horse ran round the course.

(5)

5. Choose the correct word from those within brackets.
- a. When buying a radio one must produce a (current, currant) listener's (license, licence).
 - b. Saras bought envelopes at the (stationary, stationery) counter.
 - c. The pupil was (adviced, advised) by the teacher to do his work.
 - d. The farmer threatened to (prosecute, persecute) all trespassers.

(5)

SECTION D

Read the passage carefully and answer the questions which follow.

THE CHUKA MAN-EATER

Chuka - which gave its name to the man-eating tiger of the Ladhya Valley - is a small village of some ten ploughs on the right bank of the Sarada river near its junction with the Ladhya. From the north-west corner of the village a path runs for half a kilometre along a fire track before it divides, one arm going straight up a ridge to Thak Village and the other diagonally up and across the hills to Katekindri, a village owned by the people of Chuka.

Along this latter path a man was driving two bullocks in the winter of 1936, and as he approached Chuka, a tiger suddenly appeared on the fire track. With very commendable courage the man interposed himself between the tiger and his bullocks and, brandishing a stick and shouting, attempted to drive the tiger away. Taking advantage of the diversion created in their favour, the bullocks promptly bolted to the village, and the tiger, baulked of his prey, turned his attention to the man. Alarmed at the threatening attitude of the tiger, the man ran and, as he did so, the tiger sprang on him. Across his shoulders the man had a heavy wooden plough, and on his back he was carrying a bag containing the provisions he needed for his stay at Chuka. While the tiger was expending his teeth and claws on the plough and bag, the man, relieved of his burdens, sprinted towards the village, shouting for help as he ran. His relatives and friends, hearing his shouts, rallied to his assistance and he reached the village without further incident. One claw of the tiger had ripped his right arm from shoulder to wrist, inflicting a deep wound.

JIM CORBETT: THE TEMPLE
TIGER

- a. What is meant by "a small village of some ten ploughs"? (1)
- b. What is a "fire-track"? (1)
- c. What suddenly startled the bullock driver? (1)
- d. In what way was the man brave? (2)
- e. Why was it possible for the bullocks to escape? (2)
- f. What was it that saved the driver? (2)
- g. What injury did he suffer? (2)
- h. Give the opposite of: i) approached
ii) advantage (1)
- i. Give a word similar in meaning to: i) divides
ii) attempted (1)
- j. Express in your own words the following:-
i) the man interposed himself (1)
ii) balked of his prey (1)

(15)

DEPARTMENT OF INDIAN AFFAIRS
DIVISION OF EDUCATION
GENERAL MATHEMATICS
STANDARD FIVE

TIME: $1\frac{1}{2}$ HOURS

MAX. MARKS: 75

NAME: _____

SECTION A

Write the answers only.

1. Round off 18 198 to the nearest thousand _____
2. Write 17,725 km as metres _____
3. Write 2 764 ml as litres _____
4. Write 425 cm^2 as mm^2 _____
5. $R17 - 99\frac{1}{2} \text{ c}$ _____
6. $15,3 \div 6$ _____
7. $7,6 \times 0,2$ _____
8. Write $\frac{1}{5}$ as a decimal fraction _____
9. What is 20% of R5? _____
10. Write 0,625 as a % _____

(10)

SECTION B (i)

Replace the \times by =, or \neq (Write the answers in the spaces provided.)

1. $0,9 \times 9 \%$ _____
2. $(17 + 36) \times 0 \times 53$ _____
3. $\frac{7}{4} \times 7 \times \frac{7}{4} \div 7$ _____
4. $0,08 \times 8 \%$ _____
5. $(12 \div 6) \times 2 \times 12 \div (6 \times 2)$ _____

(5)

SECTION B (ii)

Insert brackets to make the following sentences true.

1. $30 - 6 \times 5 = 0$
2. $600 \div 100 \div 10 = 60$
3. $9 \times 5 - 6 = 39$
4. $29 + 5 + 5 = 30$
5. $7,5 \div 3 + 0,5 = 3$

(5)

SECTION C

State whether the following sets are TRUE or FALSE.

1. $\{12; 16; 20\} \subset$ multiples of 4 _____
2. $\{12; 15; 18\} \not\subset$ multiples of 3 _____
3. $\{10; 20; 30 \dots\}$ are powers of 10 _____
4. $\{1; 3; 5; \dots\}$ is an infinite set _____
5. $A = \{15; 16; 17; 18; 19\}$ $B = \{a; e; i; o; u\}$
Sets A and B are equivalent _____

(5)

SECTION D

Calculate the following

1. $37,5 \text{ cm} + 35 \text{ m} + 11,2 \text{ m} + 979 \text{ cm}$ 2. $1\ 637,5 \times 4,2$
(Answer in m)

$$3. \quad 7\frac{1}{3} \div 6 \times 1$$

(3 x 4 = 12)

SECTION E

The following table shows the rainfall in millimetres, on a farm

Months	Jan.	Feb.	March	April	May	June
Rainfall	76	42	23	15	0	3

Calculate the mean rainfall per month for this farm for the period January to June.

(5)

SECTION F

The ratio of the number of apple trees to pear trees on a fruit farm is 5:3. There are 192 fruit trees altogether. How many apple and pear trees are there on the farm?

(6)

SECTION G

How many bottles of ink, each with a capacity of 75 ml can be filled from a container with a capacity of 4,425 l of ink.

(6)

SECTION H

Sally bought a radio costing R137,40 at a cash discount of 15 %. What was the discount and the cash price for the radio?

(6)

SECTION I

The circle graph below shows how a man spent his monthly income of R500. Look at the graph and answer the questions.

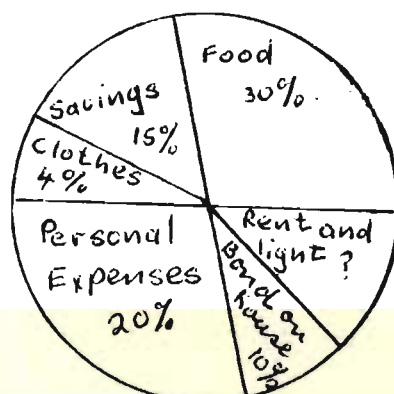

1. What amount was spent on food? (2)
2. What % was spent on rent and light? (1)
3. How much more was spent on rent and light than his personal expenses? (3)
4. What was his annual savings if he saved the same amount every month? (2)

(8)

SECTION J

The figure below is a diagram of a fish tank.

1. What is the volume of this tank?
2. If filled, what is its capacity in litres?

(7)

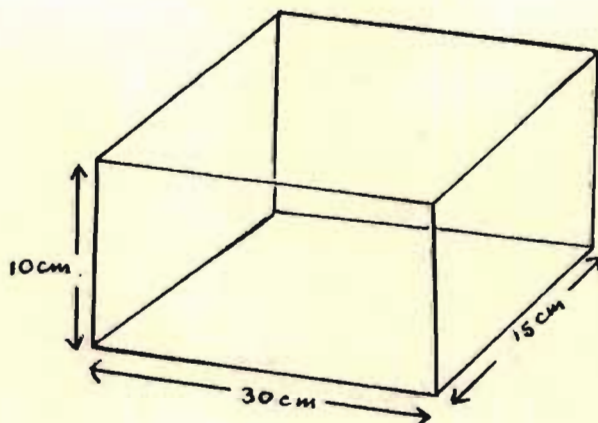

DEPARTMENT OF INDIAN AFFAIRS
DIVISION OF EDUCATION
GENERAL MATHEMATICS
STANDARD SIX

TIME: $1\frac{1}{2}$ HOURS

MAX. MARKS : 100

SECTION A

1. If $F = 2; 4; 6; 8$ and $G = 1; 2; 4$, illustrate $F \cap G$ by means of a Venn diagram (2)
2. Study the following Venn Diagram carefully and then complete the statements that follow:

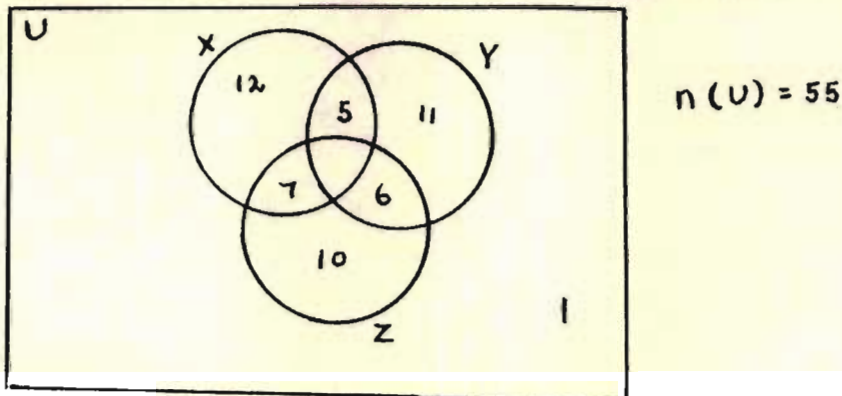

- a. $n(X \cap Y \cap Z) =$
 - b. $n(X) =$
 - c. $n(Y) =$
 - d. $n(Z) =$
 - e. $n(X \cap Y)$ only =
 - f. $n(X \cup Z) =$
 - g. $n(X \cap Y) =$
 - h. $n[(X \cap Y \cap Z)] =$
- (8)
3. If $U = \{1; 2; 3; \dots \dots \dots 10\}$; $A = \{2; 4; 6; 8\}$;
 $B = \{1; 3; 5; 7; 9\}$ and $D = \{1; 2; 3; 4; 5\}$
 State whether the following are TRUE or FALSE.
 - a. $n(A) = n(B)$
 - b. $A \cap B = \{0\}$
 - c. $A' \neq D$
 - d. $D \subset U$
 - e. $10 \in A$

(5)
 4. Illustrate $3 - 8$ on a number line. (2)
 5. Complete the following and state the number property illustrated in each:
 - a. $+5 + -5 =$
 - b. $4 \times 11 = 11 \times$
 - c. $2 \times 3 + 2 \times 4 = 2($

$(6 \times \frac{1}{2} = 3)$

SECTION B

1. Complete the following:
 - a. A _____ is the shortest distance between two points.
 - b. If the two sides of a triangle are equal, then the triangle is _____.
 - c. The measure of a straight angle is _____.
 - d. _____ angles add up to 90° .
 - e. The three angles of a triangle add up to _____ (5)
2. Make neat sketches to illustrate the following:
 - a. Obtuse angle (2)
 - b. \overrightarrow{AB} (2)
3. Calculate the measure of angle x:



4. Find the value of y and give a reason.



5. ABC is an isosceles triangle. $\hat{A} = 50^\circ$. Calculate \hat{ACD} . (3)

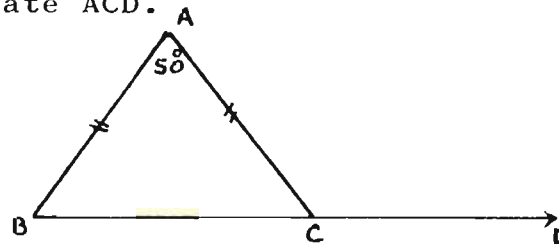

6. If $MN \parallel PQ$, complete the following statements, with reasons. (3)

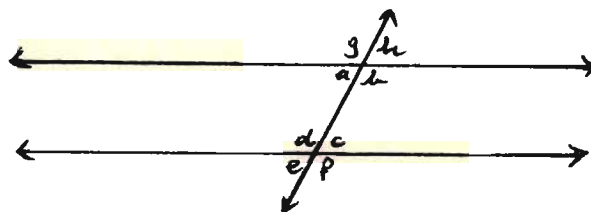

- a. \hat{a} and \hat{d} are _____ angles.
- b. \hat{d} and \hat{b} are _____ angles.
- c. \hat{f} and \hat{b} are _____ angles.
- d. If $\hat{a} = 60^\circ$ then $\hat{d} =$ _____ .
- e. If $e = 80^\circ$ then $\hat{g} =$ _____ . (7)
7. Use your protractor and draw an angle of 137° . (3)
8. Using only a pair of compasses and a ruler, construct a right angle. (4)
9. Construct ΔABC with $AB = 76\text{mm}$; $BC = 102\text{ mm}$ and $\hat{B} = 60^\circ$. Find the measure of AC ; \hat{A} ; \hat{C} . (8)
10. Draw a circle with radius 4 cm. (2)

DEPARTMENT OF INDIAN AFFAIRSDIVISION OF EDUCATIONMATHEMATICSSTANDARD SEVENTIME: $1\frac{1}{2}$ HOURSMAX. MARKS: 100SECTION A

To each of the following there are 3 suggested answers. In each case, choose the correct answer from those within brackets.

1. The multiple inverse of $\frac{3}{5}$ is $(1, \frac{5}{3}, \frac{3}{5})$
2. $5(a + b) = 5a + 5b$ illustrates the (Distributive law, Commutative law, Associative law)
3. The square root of $\frac{9}{16}$ is $(\frac{3}{4}, \frac{81}{256}, \frac{10}{17})$
4. $-15 + 7$ is equal to $(8, -8, 22)$
5. The Perimeter of a square with length 1,05 m. is $(4,60 \text{ m}, 4,00 \text{ m}, 4,20 \text{ m})$.
6. The Simple Interest on R200 for 5 years 6 months at $2\frac{1}{2}\%$ p.a. is $(R50, R55, R27,50)$.
7. $0,03 \times 2^2$ when simplified is equal to $(0,12; 0,012; 1,2)$.
8. If $a = 3$; $b = -1$; $c = 1$; then the value of $\frac{2a + 3b}{bc} = (6, 0, -6)$.
9. If $A = \{1: 2: 3\}$; $B = \{4: 5: 6\}$ then $A \cap B = (\{0\}, \emptyset, \{\emptyset\})$.
10. If $U = \{\text{natural nos. less than } 10\}$; $K = \{1: 3: 6: 9\}$ then $K' = (\{2: 4: 5: 7: 8\} ; \{1: 3: 6: 9\} ; \{2: 4: 6: 8\})$.

(20)

SECTION B

1. Draw Venn diagrams to illustrate:
 - a. $A \cap P$ if $P \subset A$.
 - b. $A \cap B = \emptyset$
 - c. $X \cup Y$ if $X \cap Y \neq \emptyset$

(6)

2. In a class of 25 pupils, 18 play cricket, 11 play soccer and 14 play volley ball.

If 3 play all games,
 9 play volley ball and cricket,
 5 play soccer and volley ball, and
 8 play soccer and cricket

Complete the following diagram and answer the questions that follow.

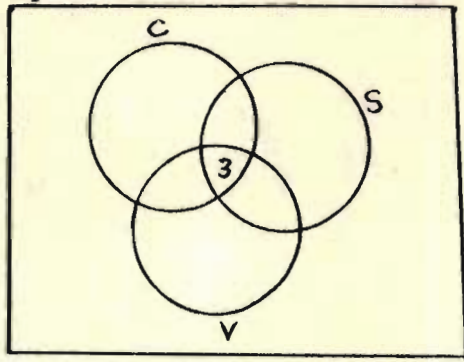

c = cricket
 s = soccer
 v = volley ball

- a. $n(s \cap v \cap c) =$
 - b. $n(s \cap v) =$
 - c. $n(s \cap v)$ only =
 - d. $n(c)$ only i.e. the number of pupils who play cricket only.
 - e. How many students play no games. (5)
3. Replace \times by an appropriate symbol e.g. $<$; $>$; $=$; \neq
- a. $\frac{2}{3} \times \frac{2}{5}$
 - b. $\frac{5}{6} \times \frac{10}{12}$
 - c. $\frac{3}{5} \times \frac{10}{6} \times 1$
 - d. $0,02 \times 0,3 \times 0,006$
 - e. 5×-7 (5)
4. A man has R200. He spends $\frac{1}{5}$ of it on food and R20 on rent. What amount does he bank, if he retains R25 for entertainment. (3)
5. Divide R200 in the ratio 2:3. (2)
6. Find the compound interest on R200 for 2 years at 5% p.a. (4)

(25)

SECTION C

1. Show on the number line (a) $-5 + - 3$
(b) $-7 + 3$ (2)
2. a. Find $2\frac{1}{2}\%$ of R200
b. Increase R200 by 2 % (2)
3. Simplify:
- a. $\frac{3}{4} \times \frac{1}{8} + \frac{3}{16}$ b. $- 4 + 2 - 3 + 1$
c. $- 4a + 2b - 3a + b$ d. $2^3 \times 2^2 \div 2^4$
e. $\frac{-16 x^4 y}{-12 x^2 y^3}$ f. $6x^3 (2x)^2$
g. $\frac{10x^3}{12} \div \frac{5}{6x^3} \times \frac{4}{3x^2}$ (14)
4. a. Multiply $- 4a + 2b$ by $2a$
b. Divide $x^3 + 4x^2 - 25x + 12$ by $x - 3$ (6)
5. Factorise a. $15a - 10b - 5$
b. $4x^2 - 9y^2$ (4)
6. Solve: a. $\frac{5}{3} x + 1 = 11$
b. $3(5x - 2) = 2(4x + 11)$ (4)

(32)

SECTION D

1. Sketch the following:
- a. Ray
b. Obtuse angle
c. Reflex angle
2. Complete the following:
- a. _____ add up to 180°
b. The sum of the angles of a triangle add up to _____
c. Alternate angles are equal if
d. _____ angles have a common arm and a common vertex.
e. Two triangles are congruent if they have the _____ and _____ (5)

3.

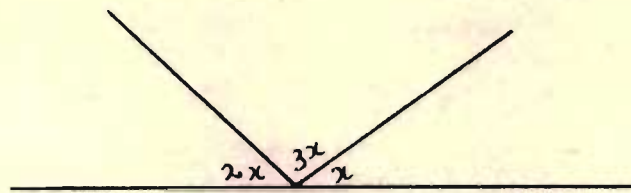

Use the above figure to find the value of x . (2)

4.

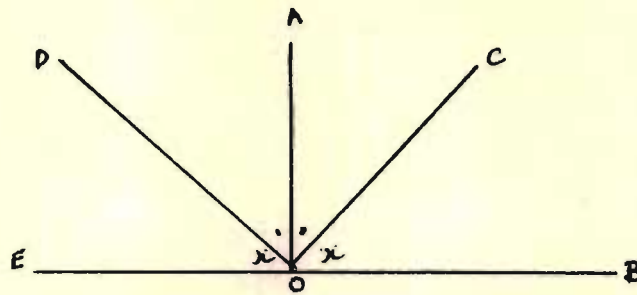

If $\hat{AOD} = \hat{AOC}$ and $\hat{DOE} = \hat{COB}$, find the value of \hat{AOB} . (3)

5.

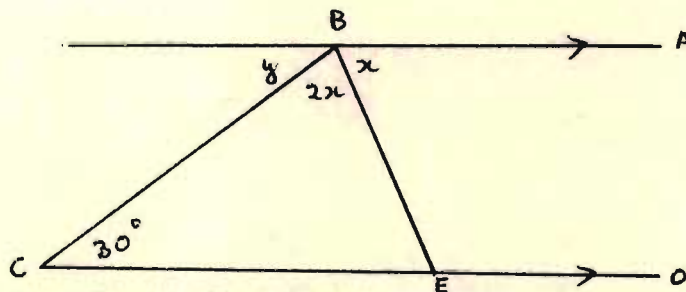

If $AB \parallel CD$ find the value of x . Hence find the value of
 a. \hat{BED}
 b. \hat{y} (3)

6. If in $\triangle XYZ$; $\hat{XYZ} = 30^\circ$ and $\overline{XY} = \overline{YZ}$ find the value of the other angles. What type of triangle is $\triangle XYZ$. Hint: sketch required. (3)

7.

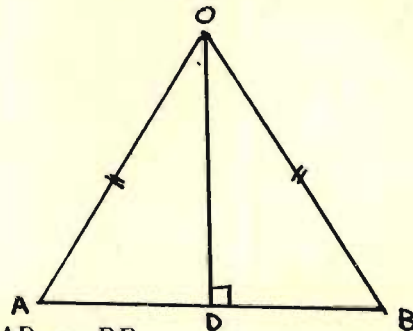

Prove: $AD = DB$
 Hint: use congruency (4)

(23)

2903 COBOL COMPILER #XEKD MK,3C/2 COBOL SOURCE FILE DATE 11/09/

```

000100 IDENTIFICATION DIVISION.
000200 PROGRAM-ID.
000300          SURV.
000350          AUTHOR , SIM NAID00.
000400 ENVIRONMENT DIVISION.
000500 CONFIGURATION SECTION.
000600 SOURCE-COMPUTER.
000700          ICL-2903.
000800 OBJECT-COMPUTER.
000900          ICL-2903 .
001000          MEMORY 10000 WORDS.
001010 SPECIAL-NAMES.
001020          *DATE IS EXEC.
001100 INPUT-OUTPUT SECTION.
001200 FILE-CONTROL.
001300          SELECT PRINT-OUT ASSIGN PRINTER 1 RESERVE 1,
001400          SELECT DET-IN ASSIGN EDS 1
001500          ACCESS SEQUENTIAL.
001600 DATA DIVISION.
001700 FILE SECTION.
001800 FD DET-IN
001850          BLOCK 2048
001900          LABEL STANDARD
001950          VALUE OF ID "TEMP-DETAILS".
002000 01 DI-REC.
002020 02 FILLER          PIC XXXX.
002050 02 CC              PIC 9.
002100 88 CC-OK          VALUE 1 2.
002200 02 SEX            PIC X.
002300 88 SEX-OK        VALUE "M" "F".
002400 02 AGE           PIC 99.
002500 88 AGE-OK       VALUE 11 THRU 19.
002600 02 IQ            PIC 9.
002700 88 IQ-OK        VALUE 0 THRU 9.
002800 02 F-OCC         PIC 9.
002900 88 FAT-OK       VALUE 1 THRU 7.
003000 02 M-OCC         PIC 9.
003100 88 MOT-OK       VALUE 1 THRU 7.
003200 02 MATHS         PIC 99.
003300 88 MATHS-OK     VALUE 1 THRU 99.
003400 02 ENGL          PIC 99.
003500 88 ENGL-OK     VALUE 1 THRU 99.
003600 02 F             PIC X(5).
003610 02 F             PIC X(68).
003700 01 DI-REC1.
003710 02 F             PIC XXXX.
003800 02 DI-CC1       PIC 9.
003900 02 STD.
004000 03 STD1        PIC 9.
004200 03 STD2        PIC X.
004300 02 GRADE        PIC X(9).
004400 FD PRINT-OUT.
004500 01 PRINT-LINE.
004600 02 FILLER       PIC X(66) OCCURS 2 .
005000 WORKING-STORAGE SECTION.
005100 77 MK          PIC 99 VALUE
005150          1.

```

105150	07	REPLY	PIC	1(24).				
105200	01	TOTALS.						
105300	02	NUMB	PIC	9(6)	COMP	SYNC	RIGHT.	
105400	02	CNT	PIC	9(6)	COMP	SYNC	RIGHT.	
105500	02	P-IND	PIC	9(6)	COMP	SYNC	RIGHT.	
105600	02	F-IND	PIC	9(6)	COMP	SYNC	RIGHT.	
105650	01	TOT1.						
105700	02	TOT-MATHS	PIC	9(6)	COMP	SYNC	RIGHT.	
105800	02	TOT-ENGL	PIC	9(6)	COMP	SYNC	RIGHT.	
105900	02	MATHS-SQ	PIC	9(6)	COMP	SYNC	RIGHT.	
106000	02	ENGL-SQ	PIC	9(6)	COMP	SYNC	RIGHT.	
106100	02	TOT-MATHS-SQ	PIC	9(12)	COMP	SYNC	RIGHT.	
106200	02	TOT-ENGL-SQ	PIC	9(12)	COMP	SYNC	RIGHT.	
106300	02	MATHS-ENGL	PIC	9(6)	COMP	SYNC	RIGHT.	
106400	02	TOT-M-F	PIC	9(12)	COMP	SYNC	RIGHT.	
106500	02	BOYS	PIC	9(6)	COMP	SYNC	RIGHT.	
106600	02	GIRLS	PIC	9(6)	COMP	SYNC	RIGHT.	
106650	01	TOT2.						
106700	02	CNTA	PIC	9(6)	COMP	SYNC	RIGHT.	
106800	02	LINE-CNT	PIC	9(6)	COMP	SYNC	RIGHT.	
106900	02	PAGE-CNT	PIC	9(6)	COMP	SYNC	RIGHT.	
107000	02	REC-CNT	PIC	9(6)	COMP	SYNC	RIGHT.	
107100	02	ERROR-CNT	PIC	9(6)	COMP	SYNC	RIGHT.	
107200	02	T-FAT	PIC	9(6)	COMP	SYNC	RIGHT.	
107300	02	T-MOT	PIC	9(6)	COMP	SYNC	RIGHT.	
107400	02	T-IG	PIC	9(6)	COMP	SYNC	RIGHT.	
107500	02	SPACING	PIC	9(6)	COMP	SYNC	RIGHT.	
107600	02	WS-IG	PIC	9(6)	COMP	SYNC	RIGHT.	
107610	02	WS-AGE	PIC	9(6)	COMP	SYNC	RIGHT.	
107700	02	F-CNT	PIC	9(6)	COMP	SYNC	RIGHT.	
107800	02	M-F	PIC	9(6)	COMP	SYNC	RIGHT.	
108000	01	HEAD-A.						
108100	02	F	PIC	X(20)	VALUE	SPACES.		
108200	02	F	PIC	X(40)	VALUE	"ERROR REPORT		
108300-		"INDICATES ERROR"						
108400	01	HEAD-B.						
108500	02	F	PIC	X(80)	VALUE	"	NO.	C/C
108600-		"AGE	IG	F-OCC	M-OCC	MATHS	ENGL	".
108700	01	DATA-LINE.						
108800	02	DL-OCC	PIC	X(17).				
108810	02	DL-FCC1	REDEFINES	DL-OCC.				
108900	03	F	PIC	XXXX.				
109000	03	DL-FAT	PIC	ZZZ9.				
109100	03	F	PIC	X(5).				
109200	03	DL-MOT	PIC	ZZZ9.				
109300	02	F	PIC	XXXX	OCCURS	2.		
109350	02	DL-TOT	PIC	X(15).				
109400	02	DL-P-MAT	PIC	ZZ9.				
109450	02	DLPP-MAT	PIC	999	REDEFINES	DL-P-MAT.		
109500	02	F	PIC	XXX.				
109600	02	DL-F-MAT	PIC	ZZ9.				
109650	02	DLPF-MAT	PIC	999	REDEFINES	DL-F-MAT.		
109700	02	F	PIC	XXX.				
109800	02	DL-P-ENG	PIC	ZZ9.				
109850	02	DLPP-ENG	PIC	999	REDEFINES	DL-P-ENG.		
109920	02	F	PIC	XXX.				
110000	02	DL-F-ENG	PIC	ZZ9.				
110050	02	DLPF-ENG	PIC	999	REDEFINES	DL-F-ENG.		
110100	02	F	PIC	XXX.				

110250	02	DLPP-BOTH	PIC 999 REDEFINES DL-P-BOTH.
110300	02	F	PIC XXX.
110400	02	DL-F-BOTH	PIC ZZ9.
110450	02	DLPF-BOTH	PIC 999 REDEFINES DL-F-BOTH.
110500	02	F	PIC X(12).
110600	02	DL-P-MATG	PIC ZZ9.
110650	02	DLPP-MATG	PIC 999 REDEFINES DL-P-MATG.
110700	02	F	PIC XXX.
110800	02	DL-F-MATG	PIC ZZ9.
110850	02	DLPF-MATG	PIC 999 REDEFINES DL-F-MATG.
110900	02	F	PIC XXX.
111000	02	DL-P-ENGG	PIC ZZ9.
111050	02	DLPP-ENGG	PIC 999 REDEFINES DL-P-ENGG.
111100	02	F	PIC XXX.
111200	02	DL-F-ENGG	PIC ZZ9.
111250	02	DLPF-ENGG	PIC 999 REDEFINES DL-F-ENGG.
111300	02	F	PIC XXX.
111400	02	DL-P-BOTHG	PIC ZZ9.
111450	02	DLPP-BOTHG	PIC 999 REDEFINES DL-P-BOTHG.
111500	02	F	PIC XXX.
111600	02	DL-F-BOTHG	PIC ZZ9.
111650	02	DLPF-BOTHG	PIC 999 REDEFINES DL-F-BOTHG.
111700	02	F	PIC X.
111800	01	DATA-LINE1	REDEFINES DATA-LINE.
111900	02	F	PIC XXXX OCCURS 2 .
112000	02	DL1-AGE	PIC Z9.
112100	02	F	PIC X.
112200	02	DL1-YR	PIC X(7).
112300	01	DATA-LINE2	REDEFINES DATA-LINE1.
112400	02	F	PIC XXXX OCCURS 2 .
112500	02	DL2-DFSC	PIC X(24).
112600	02	DL2-TOT	PIC ZZ7HZZ7BZZ7B799.
112700	01	DATA-LINEA	REDEFINES DATA-LINE2.
112800	02	F	PIC XXX .
112900	02	DLA-MO	PIC ZZ9.
113000	02	F	PIC X(5).
113100	02	DLA-CC	PIC XX.
113200	02	A-CC	PIC X(6).
113300	02	DLA-SFX	PIC X.
113400	02	A-SFX	PIC X(5).
113500	02	DLA-AGE	PIC 99.
113600	02	A-AGE	PIC X(5).
113700	02	DLA-IG	PIC 99.
113800	02	A-IG	PIC X(6).
113900	02	DLA-FAT	PIC 9.
114000	02	A-FAT	PIC X(8).
114100	02	DLA-MOT	PIC 9.
114200	02	A-MOT	PIC X(7).
114300	02	DLA-MATHS	PIC 99.
114400	02	A-MAT	PIC X(7).
114500	02	DLA-ENGL	PIC XXX.
114510	02	A-ENG	PIC X(7).
114600	01	HEAD1.	
114700	02	F	PIC X(15) VALUE SPACE.
114800	02	F	PIC X(80) VALUE "ANALYSIS OF TH
114900	-	"L AND ACADEMIC PUPILS'	SCORES IN MATHS AND ENGLISH)
115000	02	F	PIC X(15) VALUE SPACE.
115020	02	F	PIC X(5) VALUE "PAGE ".
115100	02	H1-PAGE	PIC ZZ9.
115200	02	H2-PAGE	PIC ZZ9.

J15300	02	F	PIC	X(16)	VALUE	"	STANDARD	"
J15400	02	H2-STD	PIC	X(8)				
J15500	02	F	PIC	X(7)	VALUE	"	-	"
J15600	02	H2-GRADE	PIC	X(10)				
J15700	02	F	PIC	X(18)	VALUE	SPACES		
J15800	02	F	PIC	X(5)	VALUE	"DATE"		
J15900	02	H2-EXEC	PIC	X(8)				
J16000	01	HEAD3.						
J16100	02	F	PIC	X(52)	VALUE	SPACE		
J16200	02	F	PIC	X(12)	VALUE	"MALES"		
J16300	02	F	PIC	X(28)	VALUE	SPACE		
J16400	02	F	PIC	X(20)	VALUE	"FEMALES"		
J16500	01	HEAD4.						
J16600	02	H4-DESC	PIC	X(40)	VALUE	"OCCUPATION		
J16700	02	F	PIC	X(82)	VALUE	"PASS FAIL PA		
J16800-		"PASS FAIL			PASS FAIL PASS FAIL PASS			
J16900	01	HEAD5.						
J17000	02	H5-DESC	PIC	X(40)	VALUE	"FATHER		
J17100	02	F	PIC	X(82)	VALUE	"MATH MATH EN		
J17200-		"BOTH BOTH			MATH MATH ENGL ENGL BOTH			
J18000	01	TAB1.						
J18100	02	T1-FAT			OCCURS 7.			
J18200	03	T1-MOT			OCCURS 7.			
J18300	04	T1-MKS			PIC 9(6) COMP SYNC RIGHT OCCURS			
J18400	01	TAB2.						
J18500	02	T2-AGE			OCCURS 10.			
J18600	03	T2-MKS			PIC 9(6) COMP SYNC RIGHT OCCURS			
J18700	01	TAB3.						
J18800	02	T3-IO			OCCURS 10.			
J18900	03	T3-MKS			PIC 9(6) COMP SYNC RIGHT OCCURS			
J19000	01	TOTS.						
J19100	02	PMAT			PIC 9(6) COMP SYNC RIGHT.			
J19200	02	FMAT			PIC 9(6) COMP SYNC RIGHT.			
J19300	02	PENG			PIC 9(6) COMP SYNC RIGHT.			
J19400	02	FENG			PIC 9(6) COMP SYNC RIGHT.			
J19500	02	PBOTH			PIC 9(6) COMP SYNC RIGHT.			
J19600	02	FBOTH			PIC 9(6) COMP SYNC RIGHT.			
J19700	02	PMATG			PIC 9(6) COMP SYNC RIGHT.			
J19800	02	FMATG			PIC 9(6) COMP SYNC RIGHT.			
J19805	02	PENGG			PIC 9(6) COMP SYNC RIGHT.			
J19810	02	FENGG			PIC 9(6) COMP SYNC RIGHT.			
J19820	02	PBOTHG			PIC 9(6) COMP SYNC RIGHT.			
J19850	02	FBOTHG			PIC 9(6) COMP SYNC RIGHT.			
J19860	02	WS-IND			PIC 9(6) COMP SYNC RIGHT.			
J20000		PROCEDURE DIVISION.						
J20100		START.						
J20200		ST10.						
J20400		MOVE LOW-VALUES TO TOTALS TAB1 TAB2 TAB3 TOTS.						
J20420		MOVE 60 TO LINE-CNT.						
J20500		OPEN-FILES.						
J20600		OPEN INPUT DET-IN.						
J20700		IF REPLY = 0 GO TO OF10.						
J20800		STOP "LD TEMPDETAILS".						
J20900		GO TO OPEN-FILES.						
J21000		OF10.						
J21100		OPEN OUTPUT PRINT-OUT.						
J21200		ACCEPT H2-EXEC FROM EXEC.						
J21400		MOVE SPACES TO DATA-LINE.						
J21450		MOVE 1 TO WS-IND.						
J21700		READ-DFT.						

```

J218J0    READ DET-IN AT END GO TO END=DET.
J219J0    ADD 1 TO REC-CNT.
J220J0    RD10.
J221J0    IF CC=OK GO TO RD20.
J222J0    MOVE " * " TO A-CC.
J223J0    ADD 1 TO ERROR-CNT.
J224J0    RD20.
J225J0    IF SEX=OK GO TO RD30.
J226J0    MOVE " * " TO A-SEX. ADD 1 TO ERROR-CNT.
J227J0    RD30.
J228J0    IF AGE=OK GO TO RD40.
J229J0    MOVE " * " TO A-AGE.
J230J0    ADD 1 TO ERROR-CNT.
J231J0    RD40.
J232J0    IF IQ=OK GO TO RD50.
J233J0    MOVE " * " TO A-IQ.
J234J0    ADD 1 TO ERROR-CNT.
J235J0    RD50.
J236J0    IF FAT=OK GO TO RD60.
J237J0    MOVE " * " TO A-FAT.
J238J0    ADD 1 TO ERROR-CNT.
J239J0    RD60.
J240J0    IF MOT=OK GO TO RD70.
J241J0    MOVE " * " TO A-MOT.
J242J0    ADD 1 TO ERROR-CNT.
J243J0    RD70.
J244J0    IF MATHS=OK GO TO RD80.
J245J0    MOVE " * " TO A-MAT.
J24530    ADD 1 TO ERROR-CNT.
J246J0    RD80.
J247J0    IF ENGL=OK GO TO RD90.
J248J0    MOVE " * " TO A-ENG.
J249J0    ADD 1 TO ERROR-CNT.
J250J0    RD90.
J251J0    IF ERROR-CNT = 0 GO TO READ-DET.
J252J0    ADD 1 TO E-CNT.
J253J0    PERFORM PRT-ERROR.
J254J0    MOVE 0 TO ERROR-CNT.
J255J0    GO TO READ-DET.
J256J0    PRT-ERROR.
J257J0    MOVE REC-CNT TO DLA-NO.
J258J0    MOVE CC TO DLA-CC.
J259J0    MOVE SEX TO DLA-SEX.
J260J0    MOVE AGE TO DLA-AGE.
J261J0    MOVE IQ TO DLA-IQ.
J262J0    MOVE F-OCC TO DLA-FAT.
J263J0    MOVE M-OCC TO DLA-MOT.
J264J0    MOVE MATHS TO DLA-MATHS.
J265J0    MOVE ENGL TO DLA-ENGL.
J266J0    PERFORM PRINTING THRU PR-EXIT.
J267J0    END-DET.
J26750    MOVE 0 TO WS-IND PAGE-CNT.
J26760    MOVE 0 TO REC-CNT.
J268J0    CLOSE DET-IN.
J270J0    DISPLAY E-CNT " ERRORS".
J271J0    STOP "GO TO CONT".
J272J0    PRT-REP.
J273J0    OPEN INPUT DET-IN.
J274J0    IF REPLY = LOW-VALUES GO TO PRIOR.
J275J0    STOP "LD TEMPDDETAILS".

```

```

027600      GO TO PRT-REP.
027700 PR10R.
027800      PERFORM ST10.
027830      MOVE 60 TO LINE-CNT.
027900 PR20R.
028000      READ DET-IN AT END GO TO PRT-REPORT.
028100      ADD 1 TO REC-CNT.
028150      MOVE 0 TO P-IND F-IND.
028200      IF CC = 1 GO TO PR30R.
028230      IF CC NOT = 2 STOP "C/C" GO TO PR20R.
028300      IF SEX = "F" GO TO GIRL-RT.
028330      IF SEX NOT = "M" STOP "SEX" GO TO PR20R.
028400      GO TO BOY-RT.
028500 PR30R.
028600      IF REC-CNT NOT = 1 GO TO PR60R.
028630      MOVE GRADE TO H2-GRADE.
028700      IF STD1 = 6 GO TO PR40R.
028750      IF STD1 = 8 GO TO PR45R.
028800      IF STD1 NOT = 7 GO TO PR50R.
028900      MOVE "SEVEN " TO H2-STD.
029000      GO TO PR20R.
029100 PR40R.
029200      MOVE "SIX" TO H2-STD.
029300      GO TO PR20R.
029330 PR45R.
029340      MOVE "EIGHT " TO H2-STD.
029350      GO TO PR20R.
029400 PR50R.
029500      STOP "INVALID/NO HEADER REC".
029600      GO TO PR50R.
029700 PR60R.
029800      STOP "STD DIFF".
029900      GO TO PR60R.
030000 BOY-RT.
030100      IF MATHS > 32 MOVE 1 TO CNT
030120          ADD 1 TO P-IND GO TO B1.
030200      MOVE 2 TO CNT.
030300      ADD 1 TO F-IND.
030400 B1.
030500      PERFORM ADD-RT.
030600      IF ENGL > 32 MOVE 3 TO CNT
030700          ADD 1 TO P-IND
030800      GO TO B2.
030900      MOVE 4 TO CNT.
031000      ADD 1 TO F-IND.
031100 B2.
031200      PERFORM ADD-RT.
031300      IF P-IND = 2 MOVE 5 TO CNT
031400          PERFORM ADD-RT.
031500      IF F-IND = 2 MOVE 6 TO CNT
031600          PERFORM ADD-RT.
031650      ADD 1 TO BOYS.
031700 CALC.
031800      ADD MATHS TO TOT-MATHS.
031900      ADD ENGL TO TOT-ENGL.
032000      MULTIPLY MATHS BY MATHS GIVING MATHS-SQ.
032100      ADD MATHS-SQ TO TOT-MATHS-SQ.
032200      MULTIPLY ENGL BY ENGL GIVING ENGL-SQ.
032300      ADD ENGL-SQ TO TOT-ENGL-SQ.
032400      MULTIPLY MATHS BY ENGL GIVING M-E.

```

```

1325 00      ADD M-E TO TOT-M-E.
1326 00      GO TO PR20R.
1327 00  GIRL-RT.
1328 00      IF MATHS > 32 MOVE 7 TO CNT
1329 00          ADD 1 TO P-IND
1330 00          GO TO G1.
1331 00      MOVE 8 TO CNT.
1332 00      ADD 1 TO F-IND.
1333 00  G1.
1334 00      PERFORM ADD-RT.
1335 00      IF ENGL > 32 MOVE 9 TO CNT
1336 00          ADD 1 TO P-IND
1337 00          GO TO G2.
1338 00      MOVE 10 TO CNT.
1339 00      ADD 1 TO F-IND.
1340 00  G2.
1341 00      PERFORM ADD-RT.
1342 00      IF P-IND = 2 MOVE 11 TO CNT
1343 00          PERFORM ADD-RT.
1344 00      IF F-IND = 2 MOVE 12 TO CNT
1345 00          PERFORM ADD-RT.
1346 00      ADD 1 TO GIRLS.
1347 00      GO TO CALC.
1348 00  ADD-RT.
1349 00      ADD 1 TO T1-MKS(F-OCC M-OCC CNT).
1350 00      MOVE AGE TO WS-AGE.
1350 00      SUBTRACT 10 FROM WS-AGE.
1350 00      ADD 1 TO T2-MKS(WS-AGE CNT).
1351 00      MOVE IQ TO WS-IQ.
1352 00      ADD 1 TO WS-IQ.
1353 00      ADD 1 TO T3-MKS(WS-IQ CNT).
1354 00  PRT-REPORT.
1355 00      MOVE LOW-VALUES TO TOTALS.
1355 00      MOVE LOW-VALUES TO TOT2.
1356 00      MOVE 1 TO T-FAT.
1356 50      MOVE 60 TO LINE-CNT.
1357 00  PR-A.
1358 00      ADD 1 TO T-MOT.
1359 00      IF T-MOT > 7 GO TO PR-C.
1360 00      MOVE T-FAT TO DL-FAT.
1361 00      MOVE T-MOT TO DL-MOT.
1362 00  PR-B.
1363 00      MOVE T1-MKS(T-FAT,T-MOT,1) TO DL-P-MAT.
1364 00      MOVE T1-MKS(T-FAT,T-MOT,2) TO DL-F-MAT.
1365 00      MOVE T1-MKS(T-FAT,T-MOT,3) TO DL-P-ENG.
1366 00      MOVE T1-MKS(T-FAT,T-MOT,4) TO DL-F-ENG.
1367 00      MOVE T1-MKS(T-FAT,T-MOT,5) TO DL-P-BOTH.
1368 00      MOVE T1-MKS(T-FAT,T-MOT,6) TO DL-F-BOTH.
1369 00      MOVE T1-MKS(T-FAT,T-MOT,7) TO DL-P-MATG.
1370 00      MOVE T1-MKS(T-FAT,T-MOT,8) TO DL-F-MATG.
1371 00      MOVE T1-MKS(T-FAT,T-MOT,9) TO DL-P-ENGG.
1372 00      MOVE T1-MKS(T-FAT,T-MOT,10) TO DL-F-ENGG.
1373 00      MOVE T1-MKS(T-FAT,T-MOT,11) TO DL-P-BOTHG.
1374 00      MOVE T1-MKS(T-FAT,T-MOT,12) TO DL-F-BOTHG.
1374 20      PERFORM ADD-TOTS.
1375 00      PERFORM PRINTING THRU PR-EXIT.
1376 00      GO TO PR-A.
1377 00  PR-C.
1378 00      ADD 1 TO T-FAT.
1379 00      IF T-FAT > 7 GO TO PRT-AGE.

```

```

038000 MOVE 0 TO T-MOT.
038100 GO TO PR-A.
038200 PRT-AGE.
038230 PERFORM PRIN-TOTS.
038300 MOVE 60 TO LINE-CNT.
038400 MOVE " AGE GROUP" TO H5-DESC.
038430 MOVE SPACES TO H4-DESC.
038600 MOVE LOW-VALUES TO CNT.
038700 PRA10.
038800 ADD 1 TO CNT.
038900 IF CNT > 9 GO TO PRT-IQ.
039100 MOVE CNT TO CNTA.
039200 ADD 10 TO CNTA.
039300 MOVE CNTA TO DL1-AGE.
039400 MOVE " YEARS" TO DL1-YR.
039500 MOVE T2-MKS(CNT,1) TO DL-P-MAT.
039600 MOVE T2-MKS(CNT,2) TO DL-F-MAT.
039700 MOVE T2-MKS(CNT,3) TO DL-P-ENG.
039800 MOVE T2-MKS(CNT,4) TO DL-F-ENG.
039900 MOVE T2-MKS(CNT,5) TO DL-P-BOTH.
040000 MOVE T2-MKS(CNT,6) TO DL-F-BOTH.
041000 MOVE T2-MKS(CNT,7) TO DL-P-MATG.
041100 MOVE T2-MKS(CNT,8) TO DL-F-MATG.
041200 MOVE T2-MKS(CNT,9) TO DL-P-ENGG.
041300 MOVE T2-MKS(CNT,10) TO DL-F-ENGG.
041400 MOVE T2-MKS(CNT,11) TO DL-P-BOTHG.
041500 MOVE T2-MKS(CNT,12) TO DL-F-BOTHG.
041530 PERFORM ADD-TOTS.
041600 PERFORM PRINTING THRU PK-EXIT.
041700 GO TO PRA10.
041800 PRT-IQ.
041830 PERFORM PRIN-TOTS.
041900 MOVE 0 TO CNT.
042000 MOVE 2 TO SPACING.
042010 PERFORM PR20 2 TIMES.
042020 MOVE HEAD3 TO PRINT-LINE.
042030 PERFORM PR20.
042100 MOVE " IQ GROUP" TO H5-DESC.
042200 MOVE HEAD4 TO PRINT-LINE.
042300 PERFORM PR20.
042400 MOVE 1 TO SPACING.
042500 MOVE HEAD5 TO PRINT-LINE.
042600 PERFORM PR20.
042700 MOVE 2 TO SPACING.
042800 PRI-10.
042900 ADD 1 TO CNT.
043000 IF CNT > 10 GO TO FINISH.
043100 MOVE CNT TO CNTA.
043200 SUBTRACT 1 FROM CNTA.
043300 MOVE CNTA TO DL1-AGE.
043400 MOVE T3-MKS(CNT,1) TO DL-P-MAT.
043500 MOVE T3-MKS(CNT,2) TO DL-F-MAT.
043600 MOVE T3-MKS(CNT,3) TO DL-P-ENG.
043700 MOVE T3-MKS(CNT,4) TO DL-F-ENG.
043800 MOVE T3-MKS(CNT,5) TO DL-P-BOTH.
043900 MOVE T3-MKS(CNT,6) TO DL-F-BOTH.
044000 MOVE T3-MKS(CNT,7) TO DL-P-MATG.
044100 MOVE T3-MKS(CNT,8) TO DL-F-MATG.
044200 MOVE T3-MKS(CNT,9) TO DL-P-ENGG.
044300 MOVE T3-MKS(CNT,10) TO DL-F-ENGG.

```

```

J44400 MOVE T3-MKS(CNT,11) TO DL=P-BOTHG.
J44500 MOVE T3-MKS(CNT,12) TO DL=F-BOTHG.
J44520 PERFORM ADD-TOTS.
J44530 MOVE SPACES TO PRINT-LINE.
J44600 PERFORM PRINTING THRU PR=EXIT.
J44700 GO TO PRI-10.
J44800 PRINTING.
J44900 IF LINE-CNT > 58 PERFORM PRT-HEAD.
J45000 PR10.
J45100 MOVE DATA-LINE TO PRINT-LINE.
J45200 MOVE SPACES TO DATA-LINE.
J45300 PR20.
J45400 WRITE PRINT-LINE AFTER SPACING.
J45500 ADD SPACING TO LINE-CNT.
J45510 MOVE SPACES TO PRINT-LINE.
J45600 PR30.
J45700 MOVE 1 TO SPACING.
J45800 PR=EXIT.
J45900 EXIT.
J46000 PRT-HEAD.
J46100 ADD 1 TO PAGE-CNT.
J46200 MOVE PAGE-CNT TO H1-PAGE.
J46300 MOVE HEAD1 TO PRINT-LINE.
J46400 WRITE PRINT-LINE AFTER CHANNEL-1.
J46500 MOVE 2 TO SPACING.
J46600 MOVE 0 TO LINE-CNT.
J46700 MOVE HEAD2 TO PRINT-LINE.
J46710 IF WS-IND = 1 MOVE HEAD-A TO PRINT-LINE.
J46800 PERFORM PR20.
J46900 MOVE HEAD3 TO PRINT-LINE.
J46930 IF WS-IND = 1 MOVE SPACES TO PRINT-LINE.
J47000 PERFORM PR20.
J47100 MOVE HEAD4 TO PRINT-LINE.
J47130 IF WS-IND = 1 MOVE SPACES TO PRINT-LINE.
J47200 PERFORM PR20.
J47300 MOVE 1 TO SPACING.
J47400 MOVE HEAD5 TO PRINT-LINE.
J47430 IF WS-IND = 1 MOVE HEAD-B TO PRINT-LINE.
J47500 PERFORM PR20.
J47600 MOVE 2 TO SPACING.
J47700 FINISH.
J47730 PERFORM PRIN-TOTS.
J47750 PERFORM PR20 2 TIMES.
J47800 MOVE " TOTAL - MATHS" TO DL2-DESC.
J47900 MOVE TOT-MATHS TO DL2-TOT.
J48000 PERFORM PR10 THRU PR20.
J48100 MOVE " TOTAL - ENGL " TO DL2-DESC.
J48200 MOVE TOT-ENGL TO DL2-TOT.
J48300 PERFORM PR10 THRU PR20.
J48400 MOVE " MATHS SQUARED" TO DL2-DESC.
J48500 MOVE TOT-MATHS-SQ TO DL2-TOT.
J48600 PERFORM PR10 THRU PR20.
J48700 MOVE " ENGL SQUARED " TO DL2-DESC.
J48800 MOVE TOT-ENG-SQ TO DL2-TOT.
J48900 PERFORM PR10 THRU PR20.
J49000 MOVE " MATHS X ENGL" TO DL2-DESC.
J49100 MOVE TOT-M-E TO DL2-TOT.
J49200 PERFORM PR10 THRU PR20.
J49210 MOVE " NO OF BOYS " TO DL2-DESC.
J49220 MOVE BOYS TO DL2-TOT.

```

```

J49230 PERFORM PR10 THRU PR20.
J49240 MOVE " NO OF GIRLS " TO DL2-DFSC.
J49250 MOVE GIRLS TO DL2-TOT.
J49260 PERFORM PR10 THRU PR20.
J49500 CLOSE DET-IN PRINT-OUT.
J49600 STOP RUN.
J50000 ADD-TOTS.
J50100 ADD DLPP-MAT TO PMAT.
J50200 ADD DLPP-FMAT TO FMAT.
J50300 ADD DLPP-ENG TO PENG.
J50400 ADD DLPP-FENG TO FENG.
J50500 ADD DLPP-BOTH TO PBOOTH.
J50600 ADD DLPP-FBOTH TO FBOOTH.
J50700 ADD DLPP-MATG TO PMATG.
J50800 ADD DLPP-FMATG TO FMATG.
J50900 ADD DLPP-ENGG TO PENGG.
J51000 ADD DLPP-FENGG TO FENGG.
J51100 ADD DLPP-BOTHG TO PBOTHG.
J51200 ADD DLPP-FBOTHG TO FBOOTHG.
J52000 PRIN-TOTS.
J52100 MOVE "* TOTALS *" TO DL-TOT.
J52200 MOVE PMAT TO DL-P-MAT.
J52300 MOVE FMAT TO DL-F-MAT.
J52400 MOVE PENG TO DL-P-ENG.
J52500 MOVE FENG TO DL-F-ENG.
J52600 MOVE PBOOTH TO DL-P-BOTH.
J52700 MOVE FBOOTH TO DL-F-BOTH.
J52800 MOVE PMATG TO DL-P-MATG.
J52900 MOVE FMATG TO DL-F-MATG.
J53000 MOVE PENGG TO DL-P-ENGG.
J53100 MOVE FENGG TO DL-F-ENGG.
J53200 MOVE PBOTHG TO DL-P-BOTHG.
J53300 MOVE FBOOTHG TO DL-F-BOTHG.
J53400 MOVE 2 TO SPACING.
J53500 PERFORM PR10 THRU PR20.
J53600 MOVE ZEROS TO TOTS.
****

```

```

MAP PROGRAM NAME SURV
STATISTICS: *DATA = 192 X 5.1
STATISTICS: *PROCEDURE= 49 X 5.3
CAUTION SEQ J53600 REF 606 *COR LINES READ EQUAL 573

```

EXAMPLE OF THE CALCULATION OF CHI-SQUARED (X^2)

CALCULATION OF X^2 IN A TEST OF INDEPENDENCE BETWEEN I.Q. SCORES
AND SCORES IN MATHEMATICS

	RANGE OF I.Q. SCORES						TOTAL
	70-79	80-89	90-109	110-119	120-129	130+	
Pass Maths	3(a)	49(b)	81(c)	45(d)	19(e)	5(f)	202
Fail Maths	3(g)	35(h)	17(i)	5(j)	1(k)	0(l)	61
TOTAL	3	84	98	50	20	5	263

$$\text{Chi-squared } (X^2) = \frac{(A-E)^2}{E}$$

where A = actual frequencies

E = expected or theoretical frequencies

	A	E	A-E	(A-E) ²	$\frac{(A-E)^2}{E}$
a	3*	4,6**	- 1,6	2,56	0,55
b	49	64,5	-15,5	240,25	3,72
c	81	75,2	5,8	33,64	0,44
d	45	38,4	6,6	43,56	1,13
e	19	15,3	3,7	13,69	0,89
f	5	3,8	1,2	1,44	0,37
g	3	1,3	1,7	2,89	2,22
h	35	19,4	15,6	243,36	12,50
i	17	22,7	- 5,7	32,49	1,43
j	5	11,5	- 6,5	42,25	3,67
k	1	4,6	- 3,6	12,96	2,81
l	0	1,1	- 1,1	1,21	1,10
				X^2	= 30,83

An explanation of the calculation is set out below:

APPENDIX V CONT.

- * the actual (A) number of passes in Mathematics in the I.Q. range 70-79.
- ** the expected (E) frequency is calculated by multiplying the vertical total by the horizontal total and dividing the result by the grand total in each case.

Example 1 (expected frequency for a)

$$\begin{aligned} \text{E for a} &= \frac{6 \times 202}{263} \\ &= 4,6 \end{aligned}$$

Example 11 (expected frequency for h)

$$\begin{aligned} \text{E for h} &= \frac{84 \times 61}{263} \\ &= 19,4 \end{aligned}$$

The rest of the calculations can be easily followed from the table itself.

TEACHERS ASSESSMENT OF PUPIL'S POTENTIAL

NAME OF PUPIL STD AGE

NAME OF SCHOOL

NAME OF TEACHER

Assessment to be based on a stanine-scale at the end of each school year.

STUDY HABITS	STANINE
1 Good use of time made at school	_____
2 Concentration on task at hand	_____
3 Work undetaken independently	_____
4 Classwork kept up to date	_____

ATTITUDE INTERESTS	STANINE
1 Interest in classwork	_____
2 Alertness and responsiveness in class	_____
3 Friendliness and courtesy to others	_____
4 Extra help sought when need for it is felt	_____
5 Reaction to new and different tasks	_____
6 Additional information and ideas asked for	_____
7 Ability to use knowledge	_____
8 Interest in Educational future	_____
9 Completion of projects and assignments	_____

TOTAL

Scale to be used

Outstanding	9
Very Good	8
Good	7
Above Average	6
Average	5
Need to Improve (can improve)	4
Unsatisfactory	3
Weak	2
Poor	1