

**INVESTIGATION AND DESIGN OF WET-MILL
EQUIPMENT AND PROCESS TECHNOLOGY**

Lisa Noëlle Smith

This thesis is submitted in fulfilment of the academic requirements for the Degree of Doctor of Philosophy in Engineering in the School of Mechanical Engineering, University of Natal.

August 2003

Supervisors:

Professor S Adali

Mr R Bodger

I. ACKNOWLEDGEMENTS

I would like to thank my supervisors Mr R Bodger and Professor S Adali for their guidance, support, and encouragement.

I would like to thank the T B Davis Trust and the National Research Foundation of South Africa for their financial assistance.

II. DECLARATION

I, Lisa Noëlle Smith, student number 901334880, hereby declare that this dissertation is my own unaided work, unless otherwise stated. It is submitted for the Degree of Doctor of Philosophy in Engineering, to the University of Natal in Durban. Neither this dissertation, nor part thereof, has been submitted before for any degree or examination at any other university.

As the candidate's supervisors, we have approved this thesis for submission.

Signed: _____

Name: _____

Date: _____

Signed: _____

Name: _____

Date: _____

III. CONTENTS

I.	ACKNOWLEDGEMENTS	II
II.	DECLARATION	III
III.	CONTENTS	IV
IV.	TABLE OF FIGURES	VIII
V.	SYNOPSIS	XIV
1.1.	Chapter PRÉCISES	xvi
VI.	DEFINITIONS AND ABBREVIATIONS	XVIII
1.	HISTORY OF BREAD	1
1.1.	Ancient History	1
1.2.	Middle History	3
1.3.	Modern History	5
2.	VERIFY PRODUCT CONCEPT WITH CONSUMER	10
2.1.	South African Industry Background	10
2.2.	Market Research Proves Product Viability	12
2.3.	Regulatory Issues	13
2.4.	Product Concept	14
2.5.	Production Cost Advantages	16
2.6.	Nutritional Investigation	17
3.	THE BREAD-MAKING PROCESS AND DESIGN ENVIRONMENT	20
3.1.	Main Ingredients Of Bread	20
3.2.	Bread Proving & Baking	24
3.3.	Bread Quality	26
3.4.	Production Methods	27
3.5.	Plant Bakeries	29
4.	WHEAT SUPPLY AND WET-MILL PATENT SEARCH	32
4.1.	Nutritional Composition	33
4.2.	Characteristics of Wheat	33
4.3.	Wheat Storage	35
4.4.	Grading Of Wheat	36
4.5.	Wheat Supply	37
4.6.	The Milling of Wheat	39

4.7.	Patent Search: Wet-Milling	43
5.	PRODUCT DESIGN; MACHINE AND PROCESS CONSTRAINTS	46
5.1.	Confirm Patent Recipe	47
5.2.	Recipe Ingredient Optimisation	48
5.3.	Effect Of Coarseness Of Grain On Dough Strength	55
5.4.	Maximise Percentage of Water	56
5.5.	Optimise Soak Times Through Crush Test	57
5.6.	Translational Bowl Speed effect on Heat Load	60
5.7.	Impact of Grade of Wheat On Bread	61
5.8.	Storage of Wheat And Dough	62
5.9.	Experimental Determination of Blade Loading	63
6.	VERTICAL WET-MILL CUTTER IDEA GENERATION	66
6.1.	IDEA 1: Use 'Off-the-Shelf' Large Bowl Cutter	66
6.2.	IDEA 2: Reciprocating Horizontal Drum	68
6.3.	IDEA 3: Rotating Drum With Offloading	69
6.4.	IDEA 4: Rotating Drum Above Dough Mixer	70
6.5.	IDEA 5: Vertical Wet-Mill Cutter	70
7.	WET-MILL CUTTER BLADE DESIGN VARIABLES	73
7.1.	Blade Parameters	73
7.2.	Blade Stack Height	75
8.	WET-MILL INTEGRATION INTO A PLANT BAKERY	79
8.1.	Plant Bakery Process Flow	79
8.2.	Integrated Wet-Mill Process Flow	81
8.3.	Scheduling The Wet-Mill Process	82
8.4.	Sizing of Upstream Equipment	84
9.	PROCESS EQUIPMENT DESIGN	87
9.1.	Cleaning	87
9.2.	Chilling	88
9.3.	Soaking	94
10.	WET-MILL PHYSICAL INTEGRATION	103
10.1.	Inbound Logistics	103
10.2.	Physical Integration	105
10.3.	Operation Variables	107
10.4.	Integration into Existing Process Flow	108

11. DESIGN OF A VERTICAL WET-MILL CUTTER-----	110
11.1. The Design Process-----	110
11.2. Analysis Of Plant Mixer-----	113
11.3. Wet-Mill Cutter Blade Design -----	114
11.4. Wet-Mill Cutter Mandrill and Bearings Design -----	119
11.5. Wet-Miller Cutter Pulley and Belt design-----	123
11.6. Fatigue Analysis -----	126
11.7. Deflection and Vibration Analysis-----	129
11.8. Hygienic Design-----	133
11.9. Wet-Mill Cutter Material Specification-----	134
11.10. Final Design-----	137
11.11. Wet-mill Cutter Maintenance-----	138
11.12. Wet-Mill Cutter Safety -----	139
11.13. Design Optimisation-----	140
12. STRESS ANALYSIS OF INDUSTRIAL BLADE-----	142
12.1. Finite Element Model – Original Design-----	142
12.2. Finite Element Model - Larger, Scaled Design -----	144
13. WET-MILL ECONOMICS AND INTEGRATION SCHEDULE-----	148
13.1. Capital Cost-----	148
13.2. NPV and IRR Of Wet-Mill Process -----	149
13.3. Implementation -----	151
14. REGULATORY ISSUES -----	152
14.1. HACCP-----	152
14.2. HAZOP-----	155
14.3. Safety Regulations -----	158
15. CONCLUSION-----	159
APPENDICES -----	160
Appendix A: Market Research Data -----	160
Appendix B: Nutritional Analysis & SGS Report -----	163
Appendix C: Formation of Dough-----	165
Appendix D: Vertical Wet-Mill Cutter Rig -----	166
Appendix E: Scale Ice Machine-----	167
Appendix F: FEA Drawings -----	168
Appendix G: Machine Design Calculations -----	178
Appendix H: Engineering Drawings-----	182

Appendix I: HACCP & HAZOP -----	185
Appendix J: Patent 95/7249 Extract -----	191
BIBLIOGRAPHY -----	192

IV. TABLE OF FIGURES

Summary of tables, graphs, sketches and pictures in order of appearance.

Table: History of bread 2300BC – 55BC -----	2
Table: History of bread 1307 - 1826-----	4
Graph: Value chain analysis-----	10
Table: Deregulation of bread industry-----	11
Picture: Wet-mill bread -----	15
Sketch: Wet-mill vs. standard process-----	15
Health graph 1: Mineral, base metal profile-----	17
Health graph 2: Mineral RDA as per General Nutrition Regulation 2034/1993-----	17
Health graphs 3: Fibre profile -----	18
Health graph 4: Protein profile -----	18
Health graph 5: Vitamin analysis-----	19
Health graph 6: Vitamin RDA as per General Nutritional Regulation 2034/1993 ----	19
Table: Commercially available emulsifiers -----	23
Table: Commercially available preservatives-----	23
Table: Commercially available bread improvers-----	24
Schematic: Commercial 'plant' bread making process-----	29
Picture: Lidded vs. non-lidded loaf-----	30
Picture: Plant bakery rounder -----	30
Picture: Wheat kernel -----	32
Graph: Nutrient source within wheat -----	33
Diagram of wheat germ-----	34
Table: The four characteristics of wheat-----	35
Table: Grading of wheat-----	36
Table: Protein related to harvest -----	36
Graph: Sources of wheat-----	37
Graph: Wheat production in South Africa -----	37
Table: Plant / Harvest cycle of wheat in SA -----	38
Figure: Milling process flow-----	40
Figure: Roller milling plant lay out-----	41
Figure: Nutrition vs. % Extraction -----	42
Graph: Breakdown of milling products -----	43

Table: September standard recipe-----	47
Table: September standard methodology:-----	47
Picture: 20 Litre bowl cutter-----	48
Table: Summary of first laboratory optimisation -----	49
Picture: September recipe optimisation trials-----	50
Table: Summary of second laboratory optimisation -----	50
Table: Summary of third laboratory optimisation -----	52
Sketch: Abuse test configuration -----	53
Table: Plant recipe optimisation -----	53
Graph: Chart showing all brands indexed to wet-mill bread. -----	54
Table: Coarse grain abuse tests -----	55
Picture: Coarseness standard -----	56
Table: Trial of differing water contents -----	56
Picture: TA.XT2 Texture Analyser -----	57
Graph: Temperature tracking of crush test -----	58
Graph: Figure Crush force -----	58
Graph: Figure Crush force with linear trend lines -----	59
Graph: Temperature gain during mixing-----	60
Table: Types of wheat passing abuse test-----	61
Graph: Peak loading A & B-----	63
Graph: Peak loading C and D-----	64
Table: Summary of the peak load tests-----	64
Graph: Peak loading E and F -----	65
Sketch: Force required to slice dry vs. wet grain -----	65
Sketch: Rotating vs. reciprocating efficiency -----	68
Sketch: Offloading comparison. -----	69
Sketch: Proposed arrangement of vertical cutter and dough mixer-----	70
Picture: Mounting arrangement of wet-mill cutter on the wall -----	71
Picture: Prototype vertical wet-mill machine-----	72
Sketch: Bowl cutter action zone -----	72
Sketch: Paired 60° knife arrangements-----	74
Drawing: Blade optimisation arrangements-----	74
Table: Cut time vs. no. of blades -----	75
Sketch: Blade height above bowl -----	76
Sketch: Incorrect rotation of bowl.-----	77
Sketch: Correctly rotating bowl -----	77
Table: Relationship between blade stack height and dough-----	78

Schematic: Plant bakery process flow -----	79
Model: Plant bakery mixing (note: white cells indicate inputs) -----	80
Model: Plant bakery process flow -----	80
Notes: Plant bakery process flow -----	81
Model: Wet-mill dough parameters (note: white cells indicate inputs) -----	81
Notes: Wet-mill dough parameters -----	82
Model: Wet-mill mixing parameters (note: white cells indicate inputs) -----	82
Gantt Chart: Schedule of wet-mill process -----	83
Model: Sizing of cleaning process (note: white cells indicate inputs) -----	84
Model: Sizing of wheat silos (note: white cells indicate inputs) -----	85
Model: Calculation of wheat's specific heat (note: white cells indicate inputs) -----	88
Model: Chilling capacity of various refrigerants (note: white cells indicate inputs) --	90
Notes: Chilling capacity of various refrigerants -----	90
Model: Cost of various refrigerants (note: white cells indicate inputs) -----	90
Notes: Cost of various refrigerants -----	90
Model: Wheat, water as % of dough (note: white cells indicate inputs) -----	91
Model: Scale ice scenarios (note: white cells indicate inputs) -----	93
Notes: Scale ice scenarios -----	93
Model: Continuous soak conveyor (note: white cells indicate inputs) -----	94
Notes: Continuous soak conveyor -----	94
Sketch: Continuous discharge (left) vs. centrifugal discharge (right) conveyors -----	96
Sketch: Drum soak vessel -----	97
Sketch: 'Coned' soak drum -----	98
Sketch: Rat holing and bridging -----	99
Sketch: Mass flow -----	99
Sketch: Funnel flow -----	100
Sketch: Rectangular soak tank with taper -----	101
Sketch: Transport option 1 -----	103
Sketch: Transport option 2 -----	104
Sketch: Transport option 3 -----	104
Model: Sizing of scale ice equipment -----	105
Notes: Sizing of scale ice machine -----	106
Sketch: Process plant arrangement -----	107
Table: operator procedure -----	108
Model: Bowl usage (%) x mixing time (min) -----	109
Table: Customer requirements -----	113
Drawing: Diosna Mixer -----	114

Drawing: Old versus new blade design-----	117
Drawing: Final Blade Stack Design-----	119
Drawing: Critical sections of cutter mandrill and shaft-----	120
Drawing: Blade loading and resultant force on mandrill -----	120
Drawing: Cross section of critical shaft and mandrill -----	121
Figure: Bending moment diagram of cutter mandrill and shaft-----	121
Table: Summary of stress calculations -----	122
Drawing: Final mandrill design-----	123
Table: Belt types and power requirement -----	125
Table: Belt cost and loading-----	125
Figure: Bending moment and M/EI diagram-----	129
Table: Section properties to calculate deflection -----	131
Table: Deflection due to bending stress -----	131
Table: Deflection due to torsional stress -----	132
Figure: Hygienic design examples-----	133
Table: Mechanical Properties of ASTM 440B -----	134
Table: Chemical Composition of ASTM 440B-----	134
Table: Mechanical Properties of En X39CrMo17.1 -----	135
Table: Chemical composition of En X39CrMo17.1-----	135
Table: Mechanical Properties of ASTM 316L -----	136
Table: Chemical Composition of ASTM 316L -----	136
Table: Mechanical Properties of ASTM 304L -----	136
Table: Chemical Composition of ASTM 304L -----	137
Drawing: Final vertical wet-mill cutter assembly-----	138
Table: FEA old blade model summary-----	142
Table: FEA old blade input summary-----	142
FEA XY View: Von Mises Stress Plot, Pa (The deformed model is shown).-----	143
FEA Isometric View: Total translation, mm.-----	144
Table: FEA new blade model summaries. -----	145
Table: FEA new blade Input summary-----	145
FEA Isometric View: Von Mises Stress Plot, Pa (the deformed model is shown)-	146
FEA Isometric View: Total translation, mm (The deformed model is shown). -----	146
Table: Comparative analysis of the results. -----	147
Table: Capital expenditure -----	148
Table: Standard vs. wet-mill costs break-down-----	149
Table: NPV and IRR calculations -----	150
Notes: NPV & IRR calculations -----	151

Gantt Chart: Schedule of implementation	151
Flow sheet: Wet-mill process	153
Table: HACCP analysis sheet	154
Drawing: P&ID Wet-mill Preparation	156
Drawing: Marked-up P&ID for HAZOP	157
Table: HAZOP example for first 4 lines	157
Picture: Formation of dough during first four minutes	165
Picture: Wet-mill rig	166
Figure: Old blade FEM mesh (XY plane).	168
Figure: Old blade FEM mesh (Isometric view).	168
Figure: Old blade point load 100 N @ 90 mm from the centre of rotation.	169
Figure: Old blade fully fixed nodes.	169
Figure: Old blade Von Mises Stress Plot, Pa (Isometric view).	170
Figure: Old Blade Von Mises Stress Plot, Pa. The deformed model is shown (XY view).	170
Figure: Old blade Von Mises Stress Plot, MPa. The deformed model is shown (ZX view)	171
Figure: Old blade total translation, mm (Isometric view)	171
Figure: Old blade total translation, mm. The deformed model is shown (XY view)	172
Figure: Old blade total translation, mm. The deformed model is shown (ZX view)	172
Figure: New blade FEM mesh (XY plane).	173
Figure: New Blade FEM mesh (Isometric view).	173
Figure: New blade Point load 127.5 N @ 110 mm from the centre of rotation.	174
Figure: New blade Fully fixed nodes.	174
Figure: New blade Von Mises Stress Plot, Pa (Isometric view)	175
Figure: Von Mises Stress Plot, Pa. The deformed model is shown (XY view)	175
Figure: Von Mises Stress Plot, MPa. The deformed model is shown (ZX view)	176
Figure: Total translation, mm (Isometric view)	176
Figure: Total translation, mm. The deformed model is shown (XY view)	177
Figure: Total translation, mm. The deformed model is shown (ZX view)	177
Drawing: Critical sections of cutter mandrill and shaft	179
Drawing: Original bowl cutter shaft design	182
Drawing: Arbor for cutter mandrill, DIN standard 2080	183
Drawing: Cutter mandrill	183
Drawing: Wet-mill cutter shaft	183
Drawing: Wet-mill cutter	184
Drawing: Assembly of wet-mill cutter and Diosna mixer.	184

V.SYNOPSIS

The wet-mill process is a new and unique¹ way of making bread. It eliminates the need to dry-mill the wheat into flour, and as a result, the total cost of conversion from wheat to bread is reduced. The resulting product has been perceived as being more filling than normal bread and it is also more nutritious and more affordable.

The wet-mill concept was developed in a laboratory environment and no process methodology or equipment has existed to enable the technology to be used in a real bakery environment.

The focus of this research was to design the particular equipment required for a medium plant-bakery production facility based on the wet-mill technology. Due to severe overcapacity in the bread-making industry, the research focuses on how best to integrate this equipment into an existing production facility.

Three broad areas are investigated:

- Product Development
- Process Design
- Machine Design

The aim of the Product Development phase was to create a recipe that would withstand the rigours of the plant bakery environment, while at the same time satisfying consumer demand for taste and texture.

The Process Design phase ensured that any new equipment had the capacity to match the throughput rate of the rest of the plant bakery, so that wet-mill dough could seamlessly continue downstream. Process control variables were examined to ensure that a consistent quality product was delivered. Inbound material handling was also investigated and designed to ensure safe and uncontaminated delivery of perishable raw material. Since the end product is edible, hygiene design requirements were also considered by completing a HACCP study to ensure a consumer-safe product.

¹ It is a patented concept: Patent no. 95/7249

The Machine Design phase involves the development and design of a completely new food machine: a vertical wet-mill cutter. Many ideas are evaluated and a prototype machine, based on the optimal design, was built to test the concept. This prototype was then used to define process and design constraints for a scaled, large plant-bakery machine.

The final detailed design of a plant bakery wet-mill cutter was then completed. It includes drive, belt, bearing and pneumatic cylinder selection, and shaft and blade design.

Safety considerations were an important part of the design process and production facility. Conformity to OHS Act regulations required investigation into the safe operation of the designed equipment with particular reference to driven and rotating machinery sub-regulations of the Act. A hazard analysis and operability study was also undertaken.

Lastly, the research calculates a financial valuation of the project to ascertain whether a plant baker should be interested in implementing wet-mill technology.

The research concludes with a discussion of the various successes of the three research areas, and states any further investigation that may be required before full implementation.

1.1. CHAPTER PRÉCISES

Chapters 1 and 2 give a detailed background to the project, including a broad history of bread and its uses worldwide, comments on the economics of the bread industry, and a brief description of the product profile, together with a discussion on its potential profitability in the marketplace. Chapter 3 describes the evolution of bread making and the major recipe ingredients, including a discussion of the modern 'plant bakery' as a design environment. Chapter 4 comprehensively describes the properties of wheat and the milling process and the damage that milling does to the nutritional value of the milled wheat; it also gives the results of a thorough patent search on wet-mill technology. These chapters conclude the background to the project. The knowledge researched in this section was crucial in providing the foundation for the design of a relevant and economically viable production facility.

Chapter 5 summarises over 14 months of lab work from September 1999 to March 2001. During this period two simultaneous processes occurred. The first was the design of a production-sized wet-mill machine; the second was the optimisation of a recipe for the abusive plant-bakery environment. The recipe optimisation and wheat processing trials are discussed in detail in Chapter 5. Chapter 6 culminates in the assembly of a prototype 50kg wet-mill machine.

Chapters 7 then tracks the experiments performed to understand the various blade parameters of this new machine. The chapter concludes by determining a scalability ratio for the blade stack.

Chapters 8 to 10 look at particular energy and supply issues, and investigate the physical integration of the wet-mill process in an existing production facility.

Chapter 11 takes the prototype machine from Chapter 6 and completes a full-scale plant-bakery design. This involves a detailed understanding of issues of scale, and translates into a technical evaluation of stress, vibration and fatigue of the machine parts. The blade design is a focus area, and Chapter 12 houses the detailed finite element analysis that was used to optimise the design.

Chapter 13 looks at the economic valuation of the project and the schedule of implementation. Chapter 14 addresses important occupational health and safety, and hygiene regulations.

Chapter 15 provides a clear conclusion to the project, evaluating the work that has been completed and commenting on issues that may require more attention should the project be implemented.

Appendices and a comprehensive bibliography follow the above chapters. The bibliography references all paper, book, internet, government and personal interview resources.

VI. DEFINITIONS AND ABBREVIATIONS

°C	Degrees Celsius
action zone	The section of the dough that is being cut
CBP	Chorleywood Bread Process
CO ₂	Carbon Dioxide
DCF	Discounted Cash Flow
DMR	Driven Machinery Regulation
F	Effective force (Newton)
FEA	Finite Element Analysis
FFA	Free Fatty Acids
FMCG	Fast Moving Consumer Goods
GMR	General Machinery Regulations
HACCP	Hazard Analysis and Critical Control Points
HAZOP	Hazard and Operability Study
I	Moment of Inertia
IRR	Internal Rate of Return
J	Polar moment of inertia
K _f	Fatigue stress concentration factor
K _{fs}	Torsional fatigue stress concentration factor
K _t	Geometric stress concentration factor
kJ	Kilo Joules (1000 Joules)
kW	Kilo Watt (1000 Watts)

LP	Low pressure
Lph	Loaves per hour
LSM	Living Standard Measure
MPa	Mega Pascal (10^6 Pascals)
Mt	Torque per blade
N ₂	Nitrogen
NFCS	National Food Consumption Survey Group
Nm	Newton metre
NPV	Net Present Value
OHSA	Occupational Health and Safety Act
Pa	Per annum
q	Notch sensitivity index
R	Radius (m)
Rpm	Revolutions per minute
S _a	Equivalent uniaxial bending stress (MPa)
SH	Specific Heat
SOP	Standard Operating Procedure
Temp	Temperature
Tph	Tons per hour
ΔT	Change in temperature
σ _b	Bending stress (MPa)
σ _f	Uniaxial failure strength

1. HISTORY OF BREAD

That man cannot live by bread alone is a powerful widely quoted untruth if one looks at the physical only. If we consider nutritional needs only, then bread is one of the most nutritious and life-sustaining fuels for humans. Given enough water and sunlight, physical man could well live a good life on little more than good, wholesome bread.

1.1. ANCIENT HISTORY

Although people have been making bread for thousands of years, its exact origins are unknown. During the late Stone Age, nomadic tribes probably made a thick gruel from wild grain and baked it into flat cakes on hot stones in their campfires.

Man discovered fire half a million years ago and cereals were probably roasted over open fires at least 100,000 years ago. About 10,000 B.C., man first started eating a crude form of flat bread - a baked combination of grain and water. This was possible as nomadic tribes had started settling into more permanent abodes and had started cultivating grains, among them einkorn and emmer, the ancestors of modern domestic wheat.

Ancient Egyptians are believed to have been the first to produce flour in about 8000 BC, where grain was crushed by hand with pestle and mortar. The Swiss followed suit and, around 6000 BC, were crushing grains to make a flatbread. Archaeological evidence suggests that yeast-risen wheat breads were first developed in Egypt, around 4000 years ago. The Egyptians are also believed to be the first to grind wheat flour in a process analogous to modern milling in which a grinding stone (quern) was used.

Technical advances continued to improve bread-making techniques, among them the use of the yeast-containing residue of the brewing process as a leavening agent. Bread bakers no longer had to rely on wild airborne yeast or sourdough starters, and by the 3rd century BC, yeast was manufactured commercially in Egypt. The grain industry had matured largely due to the ease of farming on the fertile banks of the river Nile. Since wheat was the only grain with sufficient gluten content to make a raised or leavened loaf of bread, wheat quickly became favoured over other grains grown at the time, such as oats, millet, rice, and barley. In about 300 BC tougher wheat varieties

were developed and the baking of bread became a skill ranked in Egypt along with that of brewing beer.

The Egyptians also invented the closed oven in which several loaves of bread could be baked at the same time. Bread and the method of bread baking assumed great significance: bread for the rich was made from wheat flour, bread for those who weren't wealthy was made from barley, and bread for the poor was made from sorghum. In fact bread was often used as the means of payment in Egypt: the workers who built the pyramids were paid in bread!

The early history of bread can be tracked as follows:

2300 BC	In India grain cultivation began along the Indus valley.
1500 BC	Horses took over ploughing from men, using the first iron ploughshares
1050 BC	The south of England became a centre of agriculture - barley and oats were grown freely.
1000 BC	In Rome, risen yeasted bread became popular
700 to 130 BC	Greeks colonized the Mediterranean. They were avid bakers, and refined flours to eliminate the impurities; seasoned their breads and cakes with honey, sesame, and fruits; and invented a stone oven for baking bread.
500 BC	Wheat in Britain had started to become important; a circular quern was developed – (a circular stone wheel turned on another which was fixed) which became the basis of all milling until the industrial revolution in the 19th century and is still the way stoneground flour is produced today.
450 BC	In Greece the watermill was invented, although it was a few centuries before its significance was fully realised.
150 BC	In Rome the first bakers' guilds were formed and well-to-do Romans insisted on the more exclusive and expensive white bread. A Roman invented the first mechanical dough-mixer, powered by horses and donkeys.
55 BC	Romans invaded Britain where wheat was still being crushed by hand and baked over open fires. More sophisticated techniques were introduced, including watermills and 5 years later the Roman authorities decreed that bread should be distributed free to all adult males.

Table: History of bread 2300BC – 55BC

1.2. MIDDLE HISTORY

During the early half of the Middle Ages, around the 5th century to the 10th century, political conditions caused trade between countries to decline. Wheat crops, grown in warm, dry climates, became less available to bakers in the cool, damp countries of northern Europe. Northern bakers perfected rye, oat, and barley breads, and a tradition of dark, 'heavy' bread-making persists in some regions of northern Europe today. It was the settling by the Saxons and Danes in Britain that introduced dark rye bread which rapidly became a staple, as rye was well suited to the cold wet climate. This trend lasted to the Middle-Ages.

Technical advances- such as the windmill- in the twelfth century allowed much larger stone querns to be used which increased efficiencies and production volumes. Hair sieves were introduced to help sift the bran from flour, leading to finer white bread. Watermills became the prime source of milling. Bakers formed guilds to protect themselves from manorial barons, and in 1155 London bakers formed a brotherhood to protect the interests of members and regulate controls governing the price and weight of bread.

In 1202 King John in England introduced the first laws governing the price of bread and the permitted profit. The growth of towns and cities throughout the Middle Ages saw a steady increase in trade, and bakers began to set up businesses. By Tudor times, Britain was enjoying increased prosperity and bread had become a real status symbol: the nobility ate small, fine white loaves called "*manchets*"; merchants and tradesmen ate wheaten cobs, while the poor had to be satisfied with bran loaves.

Many bakers were prosecuted for selling loaves that did not conform to the weights required by local laws. In 1266, the "Assize of Bread" was established to regulate the weight and price of loaves. The first bread subsidy was given - 12 pence for eight bushels of wheat made into bread. If a baker broke this law he could be pilloried and banned from baking for life. As a result of these "bread trials", bakers were ordered to mark each loaf of bread so, if a non-conforming loaf turned up, the baker could be found. These bakers' marks were among the first trademarks.

In the next few centuries, the market for bread did not change much, as can be seen in the table on overleaf. However with the advent of the industrial revolution, led primarily by Britain, dramatic improvements were made in the production and the consumption of bread.

1307	White bread bakers and brown bread bakers formed separate guilds.
1400	Chaucer wrote <i>The Miller's Tale</i> , pointing to the greedy ways of millers and their suspicious standing in society.
1569	Queen Elizabeth I united the white and brown bakers to form The Worshipful Company of Bakers
1666	The Great Fire of London, said to have been started by a baker, totally destroyed the milling and baking industry in the capital.
1700-1887	The introduction of sieves made of Chinese silk helped to produce finer, whiter flour and white bread gradually became more widespread.
1700	Wheat began to overtake rye and barley as the chief bread grain. In Paris at this time there was a peaceful uprising. The Parisians demanded 'bread of good quality in sufficient quantity at a reasonable price'
1709	In Britain, a new Act superseded the <i>Assize</i> of 1266. Magistrates were empowered to control the type, weight and price of loaves. Only white, wheaten (wholemeal) and 'household' bread were permitted ('household' bread was made from low grade flour)
1757	British bakers were accused of adulterating bread by using alum lime, chalk and powdered bones to keep it very white. Parliament banned alum and all other additives in bread.
1783	The first recorded chain of bakery shops was set up by Christopher Potter of Westminster
1815	In retaliation to the protectionist agricultural practises of France, the Corn Laws were passed to protect British wheat growers. The duty on imported wheat was raised and price controls on bread lifted. Bread prices rose sharply
1822	Standard weights for loaves were abolished. Bakers had to weigh each loaf in the customer's presence.
1826	Wholemeal bread, eaten by the military, was recommended as being healthier than the white bread eaten by the aristocracy.

Table: History of bread 1307 - 1826

1.3. MODERN HISTORY

1834 saw the first major breakthrough in production methods when roller-mills were invented in Switzerland. Whereas stone-grinding crushed the grain, distributing the vitamins and nutrients evenly, the roller-mill broke open the wheat berry and allowed easy separation of the wheat germ and bran. This process enabled the clean separation of very white flour, but it was not until the 1870s that it became economical. These steel roller-mills rapidly replaced the old windmills and watermills in high-volume milling houses.

In 1846, with large groups of the population near to starvation, the Corn Laws were repealed and the duty on imported grain was removed. This was a terrible blow to the British farming industry. However, it was the saving grace of the milling and baking industry. It was this law that was a major driving factor in propelling England into its second industrial revolution, reflected in farm labour's percentage of the total employed population which decreased from 40% to 12% by 1910¹

Meanwhile, on the other side of the Atlantic, colonial Americans made bread from cornmeal at home, baking it in the fireplace hearth. Wheat for bread became available as American settlers migrated westward to the plains- regions with climates suitable for wheat farming- and established cooperative mills for grinding grain. Railroads made grain and flour distribution efficient and cost-effective. Bread makers had to make their own yeast or rely on old dough starters for leavening until 1868, when prepared packaged yeast was made available for sale to the public. By the 1850's, the United States had 2,017 bakeries and employed over 6,700 workers.

Importing good quality North American wheat enabled white bread to be made at a reasonable cost. Together with the introduction of the roller mill, this led to the increase in the general consumption of white bread- for so long the privilege of the upper classes.

In 1887 The National Association of Master Bakers was formed in Britain.

In 1910, Americans were each eating about 210 pounds of wheat flour each year.

Tin from the flourishing mines in Cornwall began to be used to make baking tins. This technical advance paved the way for the inventions of the slicer, toaster and sandwich.

In 1912, Otto Rohwedder started work on a bread slicing machine and, after many setbacks, produced a machine that sliced bread and wrapped it to keep the moisture in. However it was only in 1928 that it was first exhibited at a bakery trade fair in America. This invention was soon followed by the introduction of the automatic toaster. Toast consumption increased as a result of both inventions.

By 1929, scientists identified the benefits of wholemeal flour and bread but this did not change the nation's overwhelming preference for white bread.

1930 saw the introduction of commercial bread-slicers for use in large bakeries. Sliced bread appeared in Britain in 1930 under the *Wonderloaf* label.

By 1933 around 80% of bread sold in the US was pre-sliced and wrapped. Americans loved it so much that the expression "the best thing since sliced bread" was coined.

During the Twentieth Century, gas ovens replaced the wood and coal burning brick ovens, producing much more even results. Large automated baking units significantly increased productivity.

In the late 1930's and early 1940's, bread was chosen as the foundation for a diet enrichment program in the United States. In 1943, the U.S. Secretary of Agriculture banned the sale of sliced bread in an effort to hold down prices during this era of wartime rationing.

Industrial and technological improvements made the time-consuming flour-refining process less expensive. White flour, once considered a delicacy for the upper classes, replaced whole-wheat flour as the cheapest, most widely produced flour. Until the early 20th century, white flour was not fortified with the vitamins and minerals lost during the refining process, and conditions caused by vitamin deficiencies became more prevalent as white bread replaced whole-wheat bread in popularity. Cases of beriberi- a condition resulting from a lack of thiamine- and pellagra- caused by dietary niacin deficiencies- increased dramatically. Many governments, including the United

¹ Creating Modern Capitalism, 1995 TK McCraw, Harvard University Press 2000 Edition pg 79. "This stunning decline of agriculture as an occupation was unprecedented in history Britain had become a truly modern society"

States, began enforcing mandatory vitamin and mineral fortification requirements. These programs have been quite successful, and cases of beriberi and pellagra are now very rare in industrialized countries. Specific amounts of iron, thiamine, niacin, and riboflavin were added to white flour. This enrichment program was a major factor in the elimination of pellagra and beriberi in the United States, as well as in reducing anaemia among Americans. It is interesting to note that South Africa is now introducing a similar fortification programme based on the April 2000 White Paper by the NFCS- "National Food Consumption Survey in Children Aged 1-9 Years"

In 1935, South Africa established a National Wheat Board to regulate and protect the wheat growers. In 1937, legislation was passed, which formalised the sale and pricing of wheat through a central body.

In England, in 1941, calcium was added to flour to prevent rickets, which had been detected as common in women joining the land army.

Late in 1941 in South Africa Jan Smuts banned the milling and refining of white flour as a wartime measure to maximise the nutritional value of the staple bread. This spawned illegal trade in house sieves, where well-to-do households separated out the bran to make confectionery items such as cakes and '*koeksusters*'.

By 1942, the London Wholesale and Multiple Bakers had joined with regional organisations to form The Federation of Bakers, to assist in organising the wartime production and distribution of bread. The 'National Loaf', roughly equivalent to today's brown bread, was introduced due to shortage of shipping space for white flour.

In 1945, at the end of the war, Jan Smuts did not repeal the ban on white flour, much to the disgruntlement of the voting population. In 1948, the National Party successfully used as one of its campaign slogans 'the bread issue' which it could be said swung the marginal vote that gave them the majority!

In 1954, the Baking Industry (Hours of Work) Act, known as the Night Baking Act, came into force in England. It was the culmination of a long campaign to control night working in bakeries. Although the poor working conditions in bakeries, which had prompted the campaign, had largely disappeared by the 1950s, the Act led to the introduction of the National Agreements of the Baking Industry between employers and the Bakers' Union, regulating working conditions in the baking industry. Although the industry has now moved away from national bargaining, the National Agreements

still form the basis for working arrangements in most companies. (The Night Baking Act was repealed in 1986)

In 1956, the National Loaf was abolished. Laws were introduced whereby all flour other than wholemeal had to be fortified with minimum amounts of calcium, iron, Vitamin B1 (thiamine), and nicotinic acid. Ever-increasing efficiency of production and distribution systems, as well as the development of the supermarket, began the shift away from bread produced by small master bakers and the emergence of the large wholesale companies.

In 1963 'The Bread and Flour Regulations' were introduced, governing the composition and additives permitted in bread and flour.

By 1965, the Chorleywood Bread Process had come into general use. This substantially reduced the long fermentation period by introducing high energy mixing for just a few minutes, dramatically reducing the time taken to produce a loaf. The process also permitted a much greater proportion of home-grown wheat to be used in the grist.

In England, during the inflationary years 1974-79, wages and the prices of most goods and services were subject to government control. In order to keep prices down, the government subsidised the price of staple foods, including bread. In April 1974, the price of a large sliced white loaf was controlled at 14.5p with the baker receiving an additional 0.5p from the government. The Bread Prices Order was revoked in April 1979, by which time the price to the consumer was 29.5p with a subsidy of 2p to the baker.

In 1981, a government health report on bread and flour recommended that the consumption of all types of bread be promoted to replace some of the fat and sugar in the nation's diet. These recommendations halted the long-term decline in bread consumption, which had taken place after World War II because of a more affluent workforce with access to an increasing variety of foods.

A much greater variety of bread became available and the share of the bread market shifted away from the master baker to the large bakery companies and the rising in-store bakery sector. This trend has been followed in the last five years here in South Africa.

In 1985, in the UK, there was a dramatic increase in the consumption of wholemeal bread, following a greater awareness of the value of bread in the diet and the development of wholemeal bread using vitamin C to produce a lighter, greater volume, more versatile loaf.

The Bread and Flour Regulations were greatly simplified. A government committee was set up in 1995 to examine the nutritional status of the population, with particular relevance to the nutritional fortification of foods. Folic acid and its importance in preventing Neural Tube Defects was to be included in the committee's work.

Longer life bread was introduced in late 1997 and rapidly became an important feature, with a 5% share of the wrapped bread market by the end of 1998.

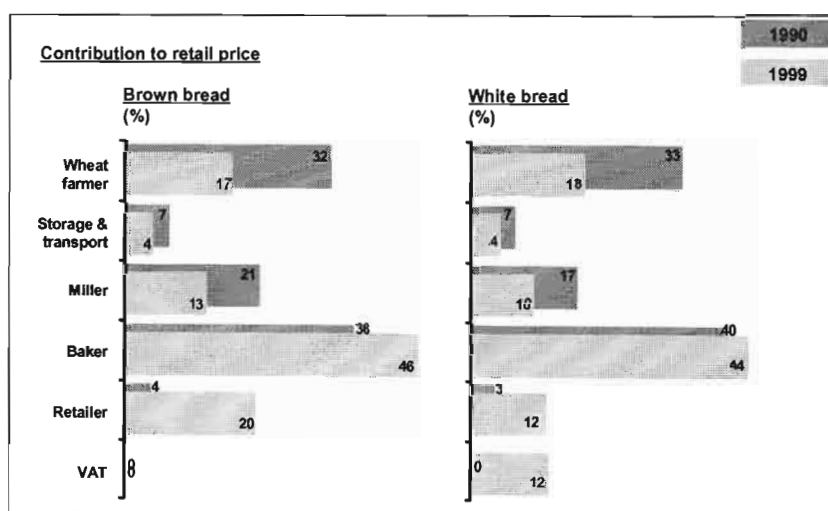
In 1998, as a result of the findings of the British Governments' committee, folic acid, a key nutrient in the prevention of serious birth defects, was added to all enriched grain foods, including bread. This legislation can only be expected to take place in South Africa once more fundamental nutritional deficiencies have been addressed.

2. VERIFY PRODUCT CONCEPT WITH CONSUMER

2.1. SOUTH AFRICAN INDUSTRY BACKGROUND

The bread industry in South Africa is large, at over R 2.7 Billion¹, and stable. Its growth over the last 3 years has tracked in line with inflation, influenced in the higher LSMs² by a move into convenience pasta, balanced by growth in the emerging middle class consumer.

Three national and one regional miller/baker company dominate the industry with 70% market share. In-store bakeries and small independent bakeries have grown from 8% to the current 30%³ share over the last decade. In addition, a number of small independent mills have entered the flour market. The influx of these new entrants has led to a massive over-capacity in the industry, followed by consolidation among the miller/bakers in an attempt to take out some of this excess capacity.



Graph: Value chain analysis⁴

1 January 2001 data – chamber of Milling

2 Living Standard Measure

3 July 2000 data – chamber of milling

4 Data: interviews, chamber of baking

Over-capacity still exists and competition on price is common in both the bread and flour markets, leading to unacceptably low margins and return on capital. As can be seen above, there was a dramatic increase in the retailer proportion of the value chain post 1990. This can be ascribed to the deregulation process that occurred in 1991 and 1997, when the wheat board was finally abolished. This process is described in the table below. The deregulation has had other consequences: it has pushed increased risk onto the farmers and forced them to compete internationally. It has opened the 'playing fields' to a proliferation of new players that have followed a boom and bust cycle following the price of wheat. It has unfortunately made it easy for unscrupulous players to sell underweight bread, thus undermining the profitability of the bread market.

Change	Impact
1935 Wheat board established	Industry control handed over to government body
1937 Wheat control scheme	Single channel for wheat purchasing with controlled pricing
1991 Price deregulation	Subsidies dropped Bread pricing uncontrolled VAT introduced on white bread Retailers increase margins on brown bread Retailers able to command larger margins In-Store bakeries arise
1995 Tariffs replace import controls	Farmers adjust their practices to balance production risks Wheat production subsidies in favour of other crops Prices become pegged at import parity (plus tariff)
1997 Wheat board closed	Wheat can be purchased from anywhere A future market arises in wheat (SAFEX) Milling industry rationalises from 137 to 106 mills Milling industry consolidates from 6 to 4 big companies Capacity utilisation decreases from 92% to 78% Bread mass controlled Bread weights uncontrolled due to lack of resources Bread variants allowed

Table: Deregulation of bread industry

2.2. MARKET RESEARCH PROVES PRODUCT VIABILITY

An initial market survey of over 300 black South Africans indicated that 66% of them select brown bread as a result of its health and affordability. In this initial research, 100% of them answered that they would, in principle, try a new healthier brown bread. Following initial production runs of the patented recipe bread, more research was undertaken to identify the key consumer buying factors for bread. These market surveys verified that the product proposition was good. In this formal sponsored research, the bread was consistently rated as 'tasty' and 'filling', and, following taste trials, 84% indicated that they would purchase this product instead of their usual brown bread. (See graphed results in appendix A).

The consumer identified nutrition as one of the key buying factors. As a consequence of this, the health profile of the bread was exhaustively examined using base criteria of 7 minerals and 8 vitamins as well as protein and fibre. The wet-mill process eliminates the need to refine flour to make bread, and therefore the entire nutritional value of wheat is converted into bread with nothing lost. The resultant bread boasts mineral, vitamin and fibre levels up to 6 times higher (including a material presence of vitamin E). This nutrition profile further endeared the product to the consumer.

2.3. REGULATORY ISSUES

2.3.1. VAT

White bread is the only major carbohydrate food to attract a charge of VAT. Brown bread however does not – this includes speciality browns such as slimmers', whole wheat bread, and seed loaves.

The industry was lobbying to have all carbohydrates VAT rated, or else to have VAT removed on white bread. They were not successful and the consensus is that the status quo will stand.

2.3.2. Fortification

A National Food Fortification Program was conducted in 1999-2000 to regulate the nutritional fortification of staple foods. Bread is top of the list, and in 2001, a working committee determined that it would be fortified with Iron, Zinc and Vitamin A.

2.3.3. Weights (1998 Trade Metrology update)

Wrapped bread may be marketed in multiples of 100g from 400g upwards, whereas unwrapped bread may be marketed in multiples of 400g from 400g up to 1.6kg. Anything less than 350g may be sold on a per-unit basis without the weight being specified

A single SABS person exists to police all trade metrology regulations nationally, and the legislation is openly flouted by non-plant bakeries.

2.3.4. Subsidisation

Subsidies were dropped with deregulation in 1991

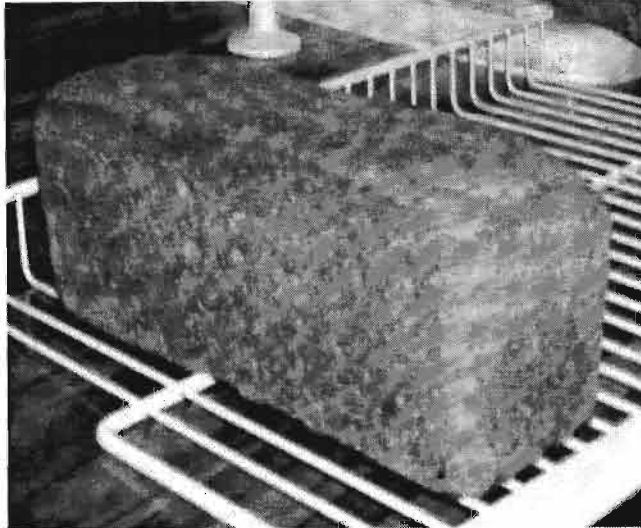
2.4. PRODUCT CONCEPT

2.4.1. Product Characteristics

The bread was trialled in a number of households for 4 months to ensure that it was a viable replacement for brown bread. No quality concerns were noted. The bread displayed the following characteristics:

- High nutritional value possible only through the wet-milling process.
- Visually very similar to a standard brown bread. If any difference had to be commented upon, it would possibly be a slightly darker colouring (as can be seen in the picture below). When toasted, the bread is quite dark in colour arising from the high quantity of bran present.
- A taste panel described the texture as 'same' or 'slightly denser' in comparison to a standard brown loaf.
- The same taste panel described the taste of the toasted bread as 'nutty'.
- The bread was sliced in a number of shop-floor cutting devices. All these cuts were successful, with no crumbling or tearing of the bread in evidence.
- The 4-month household usage also tested the bread's ease of 'spreadability'. The bread exhibited no tearing or crumbling when a spread was applied and behaved exactly as a standard brown bread.

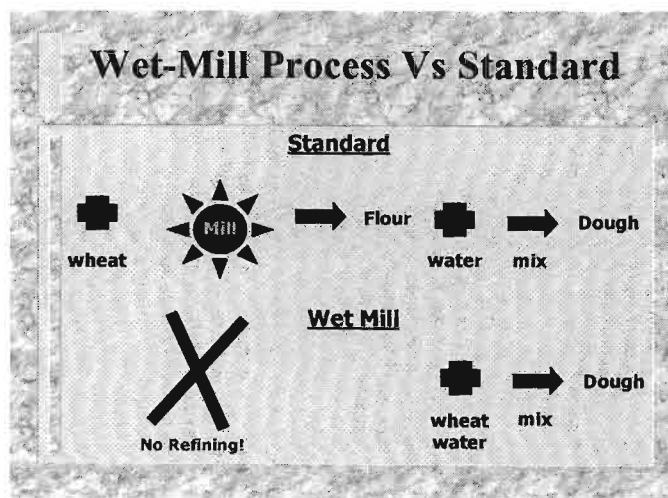
In conclusion, the bread has higher nutritional value but no adverse performance variables that would sway the consumer from a repeat purchase.



Picture: Wet-mill bread

2.4.2. Patent Search

The competitive advantage of this product lies in the process used to make it. This process – the “Wet-mill Process’ has been patented. The front page of the patent has been included in the appendices. There is thus a formidable barrier to entry for others who may wish to compete on either nutritional or health platforms. An official patent search by patent lawyers in May 2000 revealed no similar process in either the USA or UK. A world-wide-web search also revealed no similar process.



Sketch: Wet-mill vs. standard process

The wet-mill process converts cleaned whole wheat into dough. This is ‘stage 1’ in the bread making process and is unique. It is referred to as ‘wet-mill’ as it eliminates the need to dry-mill wheat into flour as per the sketch above. The dough so produced can

then be treated as per a normal bakery; yeast is added, the dough proved and then baked into bread.

The process has been tested for robustness. Wheat of varying protein contents were tested, even utility wheat not normally used for bread making (see Chapter 6 on experimental results for a description of all the optimisation tests). All the wheat produced acceptable loaves of bread.

In addition, during a rework trial, it was discovered that old, stale bread added to the wet-mill mixture resulted in a thick dough, which, with some small addition of minor ingredients was easily modified to a biscuit mixture. This allows for the purchase of waste product from the competition (which is currently disposed of at a cost) to produce biscuits. This is a very relevant cost saving for those plant bakeries that have diversified into confectionery. This option has not been explored further in the thesis.

2.4.3. Risk of Reverse Engineering

The risk of possible reverse engineering of the process to enable a design modification to render the patent useless has been investigated. The patent is both specific and general: for example, the preferred method of mixing is not specified, thus covering all or any machines that might be used.

2.5. PRODUCTION COST ADVANTAGES

Due to the production process not requiring milled flour, the cost of raw materials is substantially lower at 26%¹. When adding in the cost of additional capital requirements, the total cost advantage over traditionally manufactured brown bread results in a DCF IRR of 63%².

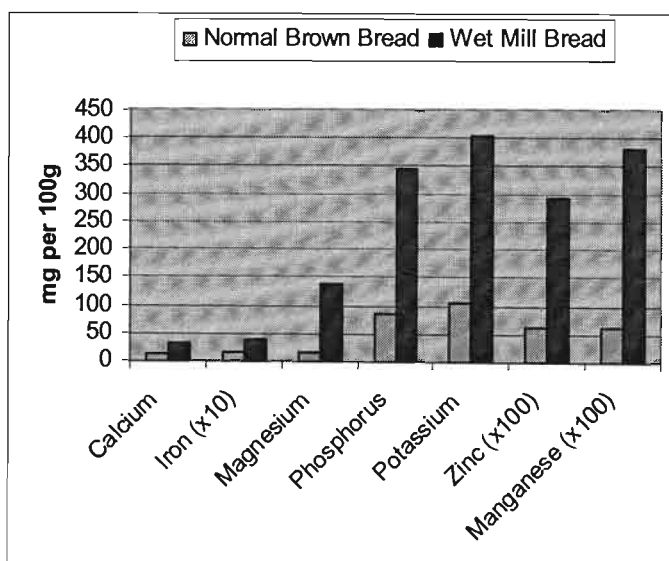
¹ Total ingredient cost saving for an industrial plant baker. The detailed calculation can be found in Chapter 5.2.

² The DCF (Discounted cash flow) calculation can be found in Chapter 13.2

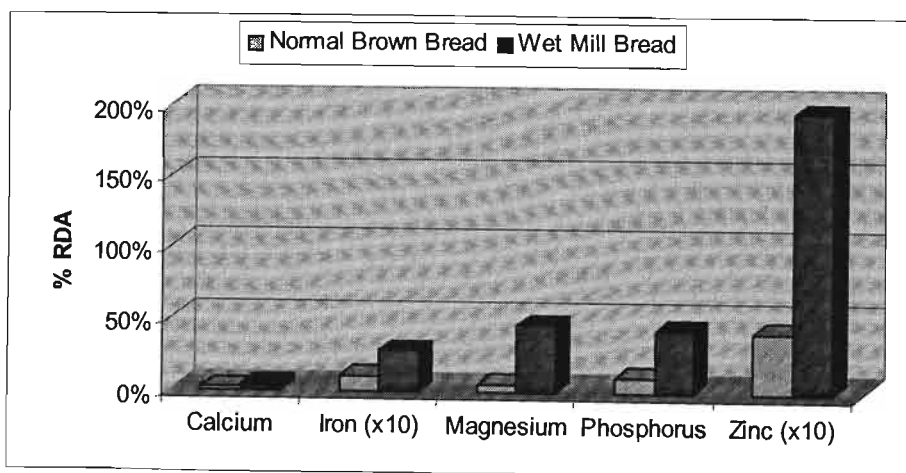
2.6. NUTRITIONAL INVESTIGATION

As indicated earlier in this chapter, the consumer found the nutritional benefit of the bread a key reason to buy it. As a result, a comprehensive analysis of the bread was undertaken and compared to published (non-fortified) brown bread data. The source data for this analysis was as per South African Medical Research Council's nutritional tables for cereals. Protein, mineral, fibre and vitamin profiles were compiled for both products (see Health Graphs 1 to 6 below). A copy of the SGS laboratory report can be found in appendix B.

2.6.1. Mineral Analysis

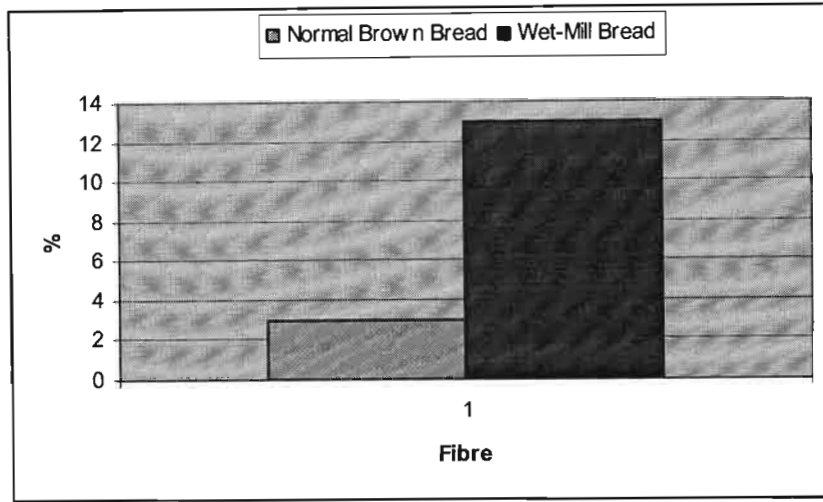


Health graph 1: Mineral, base metal profile



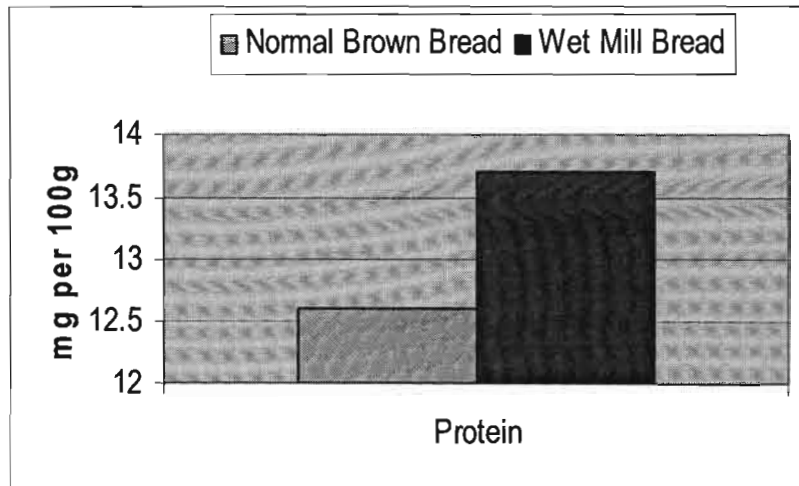
Health graph 2: Mineral RDA as per General Nutrition Regulation 2034/1993

2.6.2. Fibre Analysis



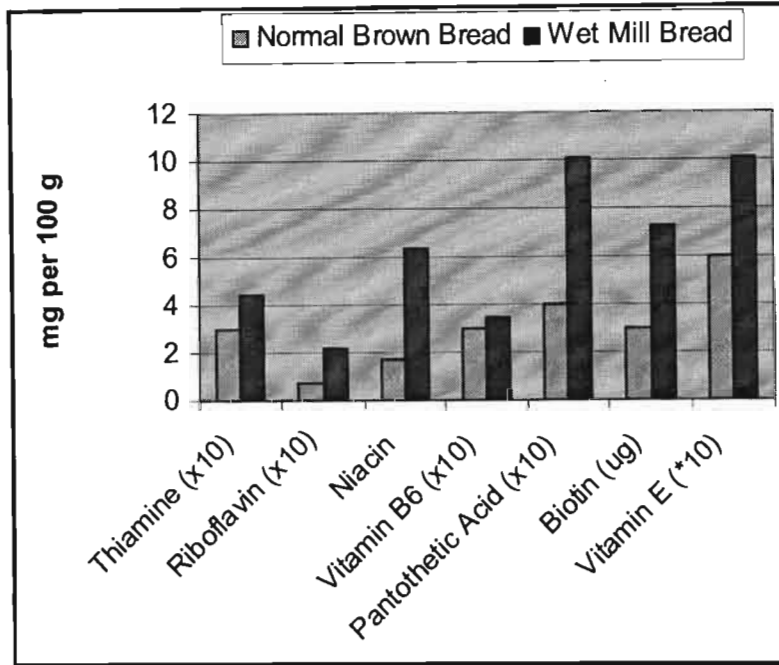
Health graphs 3: Fibre profile

2.6.3. Protein Analysis

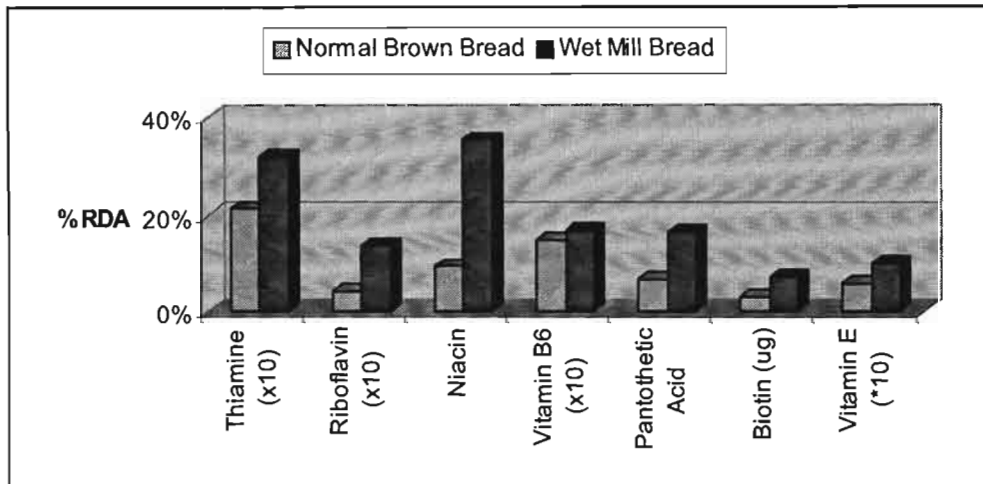


Health graph 4: Protein profile

2.6.4. Vitamin Analysis



Health graph 5: Vitamin analysis



Health graph 6: Vitamin RDA as per General Nutritional Regulation 2034/1993

3. THE BREAD-MAKING PROCESS AND DESIGN ENVIRONMENT

In the previous chapter, we developed a product that was tested with and found acceptable to the consumer. The bread thus far has been made in small quantities in a lab. However, the aim is to have the bread made on a large scale in an industrial plant.

Although we have been making bread for more than 6 000 years the process itself is still not clearly understood. This chapter explores how bread is made and looks in particular at the plant bakeries. The plant bakery forms the design environment in which the product will be made and in which the scaled custom-designed machine must operate.

3.1. MAIN INGREDIENTS OF BREAD

The basic ingredients of bread are flour, yeast, salt and water. However, in industrial production additives such as enzymes, vitamins and preservatives are often used to improve the quality and to keep production costs low.

3.1.1. Flour

Baking is not an exact science. A major problem faced by the majority of the bread-making industry is that the quality of different batches of flour can only be judged by using them to bake a loaf. Machines do exist that take a mixture of flour and water, and work it into a balloon to test its strength. However, their cost prohibits smaller bakeries in South Africa from procuring them. Wheat flour is best adapted for bread making, as it contains sufficient natural gluten to make a leavened (light, spongy) loaf. Cake flour is the most refined (and therefore the least nutritious) flour; it is also the most profitable milling product. Bread flour, on the other hand, is the bulk product of the milling industry and, in South Africa, the vertically integrated¹ massive plant

¹ When a company extends its influence/ownership either upwards or downwards along the value chain.

bakeries seem to exist purely to 'burn' this product and thus allow them to maximise profitability from cake flour. Brown flour is not actually a milling product; it is white bread flour to which a legislated fixed percentage of bran is added. (Milling is discussed in more detail in the next chapter.) Variability between flour batches can lead to costly wastage. This is a particular problem with European wheat, where the changeable climate can affect the bread-making properties of the flour. In South Africa, depending on whether the plant bakeries are using imported wheat or local wheat (and indeed from which region), they have to significantly modify the process to manage the change in properties. The type and amount of the essential proteins in the flour varies depending on the environmental conditions in which the wheat was grown. Flour is mostly starch, but also contains proteins, known as gliadins and glutenins. The combination of gliadins and glutenins is referred to as the gluten complex.

3.1.2. Gluten

The wheat protein complex, gluten, is a grey, tough, elastic substance, insoluble in water. The elastic framework of gluten holds the gas produced by the fermentation action of yeast, which otherwise would escape. If the gluten is too strong, the loaf won't rise, as the gas bubbles can't form properly in the dough. But if the gluten isn't strong enough, the bubbles become too large and the loaf ends up with a hole in the middle. When the dough is cooked the gluten 'sets', which traps the gas bubbles within the loaf.

3.1.3. Yeast

Yeast requires moisture, food and warmth for growth. When these requirements are satisfied, the yeast spores rapidly multiply and initiate the fermentation process which gives bread its characteristic aroma. Yeast is a microscopic fungus consisting of spores that can be found naturally in air.

Fermentation is the process by which yeast attacks some of the starch in flour, and changes it to dextrose (sugar) which is, in turn, converted into alcohol (C_2H_5HO) and carbon dioxide (CO_2). There are, broadly, three types of fermentation: alcoholic, acetic, and lactic. Bread dough fermentation (by the addition of yeast) is alcoholic. However, if this were to be allowed to continue unchecked then acetic fermentation

would start. Lactic fermentation is not relevant to the bread making process (it takes place when milk sours).

Liquid, dry, or compressed yeast may be used in making bread. In plant bakeries, compressed yeast cakes are now almost universally used, having replaced the home-made liquid yeast. The use of fresh yeast is critical in bread making and the absence of dark streaks on the yeast cake is important to show this freshness.

The yeast plant is killed at 212°F (100°C); life is suspended, but not entirely destroyed at 32°F (0°C). The temperature best suited for its growth is from 65°F (18°C). The most favourable conditions for the growth of yeast are a warm, moist, sweet, nitrogenous environment.

3.1.4. Salt

Salt is an essential ingredient in bread. It is used in very small amounts to give bread flavour. It also helps to control fermentation to produce bread of good volume and texture.

3.1.5. Water

Water is used to produce the dough. It is important that the water is of the correct temperature and quantity as it affects the quality of the dough as well as the dispersal of the other ingredients.

3.1.6. Fat

Vegetable fat is used in very small quantities; it helps to keep the bread soft and also helps the dough pass more easily through the production process. The melting point of the fat used in plant bakery production has become a focus of research, as there is an effect called 'oven spring' where the dough expands further during baking, facilitated by the lubricating action of the fat. The wet-mill process uses SSL (sodium

stearoyl lactylate) which is produced from stearic acid and lactic acid¹ that has been neutralised with sodium salt.

Some of the emulsifiers (fats or fat replacements) used by industry are described below:

Masterfat	A high viscosity emulsified fat, perfectly balanced to give fine separation and complete dispersal throughout the dough. Use at between 1% and 2% for Fancy Breads and Rolls. For standard type breads add 2% to 5% on flour weight.
SB Fruitloaf Compound	A high viscosity emulsified fat compound especially developed for fruit loaves and buns to give them an extended shelf life. Use at the rate of 2% to 5% on flour weight.
Bundo X	A high viscosity emulsified fat for buns and all sweet fermented products. Produces a first class product with maximum volume, even texture, rich flavour and excellent keeping qualities. Use at the rate of 2% to 5% on flour weight.
Bakels Liquid Shortening	A Liquid Shortening for use in bread, rolls, confectionery and biscuits.

Table: Commercially available emulsifiers

3.1.7. Preservatives

These give bread extended shelf life and prevent the formation of various moulds. Some commercially available preservatives:

Sorbex	An excellent mould inhibitor for confectionery and pies. Use at the rate of 75gr and 100gr per 50 Kg total weight of batter or pastry.
CSP 60: Calcium Propionate	An effective rope and mould inhibitor for yeast-raised doughs. Use at the rate of 0.15% to 0.25% on flour weight.
Ropal Agglomerate Calcium Acetate	A rope inhibitor of the purest quality, suitable in all yeast-raised goods. Use at the rate of 0.2% to 0.25 % on flour weight.

Table: Commercially available preservatives

The wet-mill process, for instance uses calcium propionate as it is reasonably priced and robust.

¹ Swedex SSL product data sheet, 24/11/1999. Re-approved 23 July 2002.

3.1.8. Bread Improver

Vitamin C (ascorbic acid) is used to strengthen the dough and help it rise. It has a beneficial effect on the volume, crumb structure and softness of the bread. Ascorbic acid is a cheap and very effective 'robustness' agent.

Some examples of commercially available improvers are:

Voltem Quick	A composite bread or roll improver. Recommended for rolls, fancy bread and starch reduced doughs requiring a bulk fermentation of 10 minutes. Use at the rate of 1.5% to 2% on flour weight.
Rolltem 2000	Specially formulated no-time dough premix for the production of fancy bread and bread rolls. Use at the rate of 6% on flour weight.
Lecinta 650	A composite bread or roll improver containing emulsifiers, oxidants, yeast foods but does not contain Ropal. May be used with the addition of 0.25% Bakemul D. Lecinta 650 is designed to give improved loaf quality and longer shelf life. Use at the rate of 0.5 to 1% for bread and up to 2% on flour weight for fancy breads and rolls.
Lecitem 2000	A superior emulsified bread improver to suit a variety of production methods. Use at the rate of 1.5% to 2% on flour weight.
Lecitex 20/30	A carefully formulated composite bread improver containing preservatives, emulsifiers, oxidizing agents and yeast and dough conditioners. Lecitex 20/30 is suitable for both white and brown bread. Use at the rate of 1% on flour weight and 0.3% fat may be added.
Lecicool	An improver for the production of frozen doughs. Use at the rate of 3% on flour weight. Only made to order.
Lecimax	A superior roll improver. Suitable for crispy rolls. Used at 2% on flour weight.
Super Lecitex B	Improver for special breads and rolls. Used for no-time doughs. Use at the rate of 1.5% to 2% on flour weight.
Lecitem Pumpable	A liquid improver blend of emulsifiers, enzymes and vegetable oils. Use at the rate of 0.3% to 0.5% on flour weight in bread and 0.75% to 1% on flour weight in rolls.
Dobrim Extra	An improver for white and brown bread and baguettes. Use at the rate of 0.1% to 0.3% on flour weight.

Table: Commercially available bread improvers

3.2. BREAD PROVING & BAKING

3.2.1. Developing Bread

Bread is made by mixing flour, water, salt, and yeast. Sugar can be added to hasten the fermentation. Dough is then kneaded and allowed to stand for about 10 minutes at room temperature, or until the dough has doubled in size. This process of fermentation is described above in the section on yeast. The dough is then kneaded a second time to break the bubbles and evenly distribute the carbon dioxide. It is then divided into a standard weight to produce a legislated final grammage of dough.

3.2.2. Moulding

Moulding is the bread baking term for rolling; however there is an art to good moulding. The dough must not have any included pockets of air: this is so important that the dough is treated quite roughly to remove any bubbles.

3.2.3. Proving Bread

The dough is placed into greased bread pans and placed in a prover (usually) at 40°C. In the large plant bakery, a release agent (polyglycerol polyricinoleate¹) is used rather than hard fat to minimise cleaning costs (baked hard fat being difficult to remove) as well as to reduce the risk of rancidity. Proving is a critical process step, as, if the dough is allowed to prove for too long, the final bread will be full of large holes; if it has not proved enough, it will be heavy and soggy. Other things can also go wrong, such as placing dough in a hot pan, causing the bottom layer of dough to cook too quickly, producing an increasing denseness toward the bottom of the loaf.

3.2.4. Baking of Bread

Bread is baked:

- To kill yeast
- To make the starch soluble
- To evaporate off alcohol and carbon dioxide
- To form a brown crust and a pleasant flavour.

Bread is baked in a hot oven (around 240°C). The dough continues to rise for the first fifteen minutes of baking (oven spring), when it should begin to brown, and continue browning for the next twenty minutes. If the oven is too hot, however, the crust will form quickly and prevent the important oven spring. In continuous ovens there are up

¹ There are a number of commercially available release agents such as "Pan Emulsifier" by Bayers, "Knock-out Pan Oil" by IBI and "Pan Releasing Agent" by Jamun Foods. Their prices range from R4 to R5 per liter in Jan 2003.

to 5 different temperature settings to maximise the efficiency of each stage in the process. The bread is removed immediately from the pans while it is hot and placed in a cooler. The cooling determines the final properties of the bread: if a soft crust is required, then the bread needs to be cooled in a very humid atmosphere (in home baking this would be equivalent to wrapping/covering the bread with a cloth); a crusty loaf results from normal ambient cooling.

3.3. BREAD QUALITY

Bread quality encompasses many aspects of the bread from the aesthetic to the functional. The five key quality determinants are described below:

- 'Mouth Feel'

It must not taste yeasty (or uncooked) and it must not be bitter. Ingredients such as salt are more difficult to quantify: if 50% of the people complain that it is too salty and the other 50% complain that there is not enough salt – then the salt content is correct! The moistness of the bread is critical to whether people enjoy eating it or not. A dry loaf is difficult to eat, and it is therefore critical to maximise the quantity of water per loaf. This is a bigger issue in South Africa, as a large percentage of the population eats bread without spread¹

- External Appearance

This can be influenced by the quality of the dough as well as the bake. If the outside has 'stretch marks', then the dough had been over-developed. If there are dark streaks, then the dough has been contaminated with the mould 'rope'. If it is too pale, then it has not been cooked long enough and if too dark, it has spent too long in the oven.

- Strength

This is determined by cutting a slice of the bread and, taking diagonally opposite corners, pulling it gently. If the bread can withstand this treatment in either direction without breaking or cracking, then the dough strength is good.

¹ Interview with Unilever Marketing Manager, Jackie Reiser, November 2001

- Internal Structure

There are a number of things to look for internally: the most important feature is that the crumb structure should remain constant from top to bottom. The finer the cell-structure of the bread, the better the quality thereof. There should be no air inclusions (caused by incorrect moulding). The quantity of crumbs left after cutting a slice also indicates quality: the fewer crumbs the better the quality of the bread.

- Shelf life

This used to be linked to the quality of the dough and the water content of the bread. Nowadays a loaf can stay soft indefinitely, due to the addition of various enzymes and bread improvers (such as described above). It is thus possible for a 12 day old loaf covered in mould to still feel lovely and fresh!

3.4. PRODUCTION METHODS

There are two main methods of making bread: the Bulk Fermentation Process (BFP) and the Chorleywood Bread Process (CBP).

3.4.1. Bulk Fermentation Process (BFP)

BFP is the traditional method of making bread: ingredients are mixed together to form a dough and left to ferment. During fermentation the dough changes from a short dense mass into an elastic dough. The time taken to reach this state largely depends on the amount of yeast and the dough temperature. The three variations described below are the most common¹:

- A 3-hour bulk fermentation time, with a short remix in the middle (after about 1.5 to 2 hours), called the knock-back.
- A 3-hour process as above but omitting the salt at the dough-making stage and adding it at the knock-back stage – called the delayed salt method. (Salt has a

¹ Kamel, B.S. & Stauffer 1993, *Advances in Baking Technology*, pg 44-47

retarding effect on fermentation, and its absence allows a higher rate of fermentation prior to the knock-back).

- The sponge and dough process. In this process 25% of the flour is made into a dough and left to ferment for 12-16 hours. It is then mixed into the final dough with the rest of the ingredients and left to prove for only 30 minutes.

The BFP has the following disadvantages which ultimately led to the development of the mechanical development process to eliminate many of these problems:

- The degree of fermentation was affected by ambient temperature changes. (A lot more yeast had to be added if the ambient temperature was cold.)
- The fermenting dough took up space in the bakery, with large amounts undergoing fermentation at any one time. Thus a large volume of dough was liable for spoilage if there was a mechanical or process breakdown.
- The 3 hour BFP makes it difficult for the bakery to react to short notice orders and requires that the dough-maker start 3-4 hours before the production operators so that dough is ready for them to begin processing- a difficult management situation.

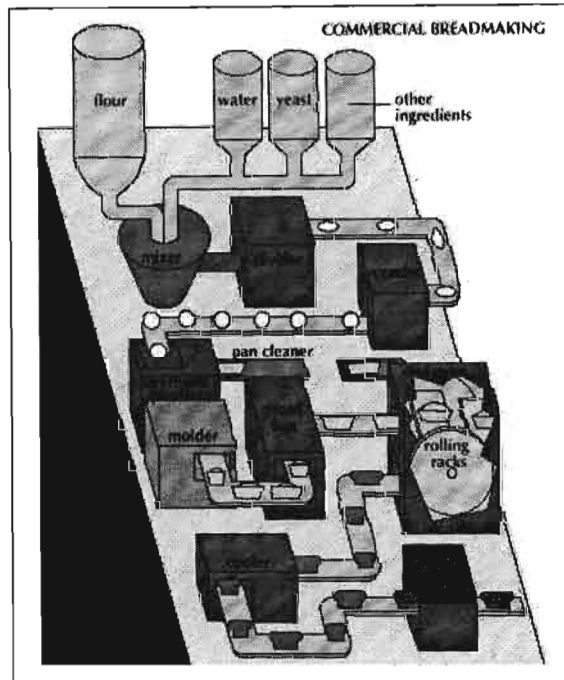
3.4.2. Chorleywood Bread Process (CBP)

The modern commercial process used in large bakeries is known as the Chorleywood Bread Process and was developed in 1961 by the Flour Milling and Baking Research Association at Chorleywood. This method produces bread without the need to ferment the dough in bulk. Dough development in CBP is achieved by the rapid high speed mixing and intense mechanical working of the dough. CBP is the most common method used throughout all sectors of the bread baking industry, largely due to this time saving method.

Compared with bulk fermentation dough, CBP dough has increased yeast and oxidising agent levels to maintain normal proof time and increased water of about 5% to give dough of the correct consistency. A higher dough temperature is employed in CBP than for bulk fermentation. This is to aid the yeast fermentation rate during the

final proof. It also aids chemical and biological reactions essential to complete dough development¹

3.5. PLANT BAKERIES

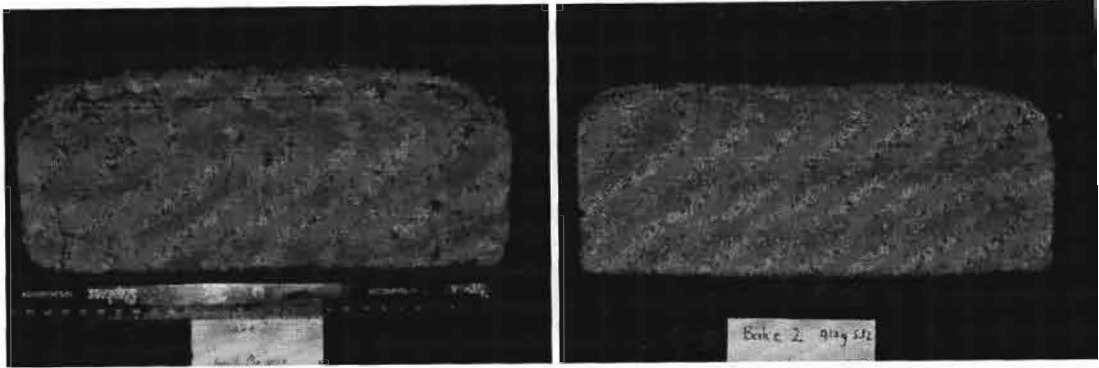


Schematic: Commercial 'plant' bread making process²

The plant bakery follows the standard CBP way of making bread, which is schematically described above and then explained in more detail below. An interesting development linked to the advent of plant bakeries and the increased popularity for bread eaten as toast is the lidded or square loaf. When the dough is placed in the tin tray, it is either proved to the top of the tin and baked to produce a rounded crust loaf (the loaf on the left in the picture below), or it is proved to about 8mm -10mm below the top of the tin. A lid is then placed over the dough and it is baked into what South Africans know as the 'standard government loaf' or the square 'sandwich loaf' which can be seen on the right in the following picture.

¹ Kamel, B.S. & Stauffer 1993, Advances in Baking Technology, pg 51

² British Master Baker's Guild's training manual.



Picture: Lidded vs. non-lidded loaf

3.5.1. Mix

The dough is mixed intensely for about three minutes in a high speed mixer in batches of around 300 kilograms. The temperature of the dough has to be carefully controlled at 28°C so that the yeast can grow and the dough become elastic. When mixing is complete, the large mass of dough is tipped into a divider.

3.5.2. Divide

The dough is then divided into individual pieces. The weight of each piece of dough is very important to ensure that the finished product complies with Trade Metrology. Volumetric measurement of the dough is important for yield management.

3.5.3. Rounder

The rounder creates a round shape to allow even development of bubbles during the pre-proving process. A typical plant bakery rounder is shown below:



Picture: Plant bakery rounder

3.5.4. Pre-prove

The dough pieces are allowed to `recover` for about eight minutes in a stacked conveyor prover. This is the first or intermediate proving stage which allows a film to form around the dough to facilitate handling.

3.5.5. Mould

Each piece of dough is then shaped and moulded and placed in a tin. There are four tins to a tray. The texture and size of the dough-piece is automatically controlled to optimally rise in the chosen tin - usually a chubby sausage shape.

3.5.6. Prove

This is the most important step in baking. The final prover allows the dough to rise gently for about 55 minutes in strictly controlled temperature and humidity conditions. It is then ready for baking.

3.5.7. Bake

The bread is baked for about 20 minutes at 200-240°C which hardens the gluten bubbles to ensure a permanent shape.

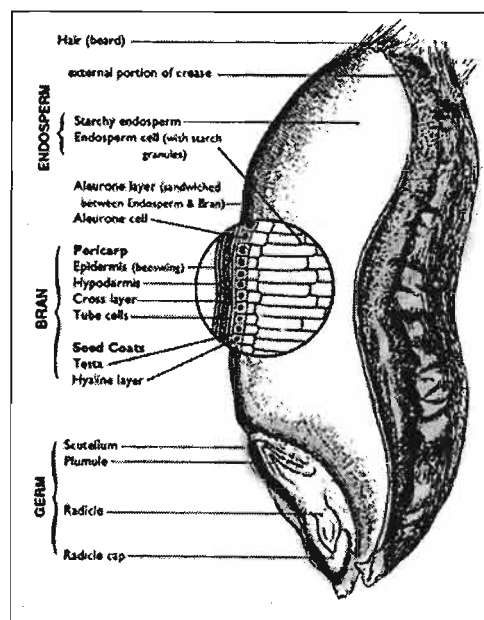
3.5.8. Cooling

The loaves then go into a cooler. Cooling is usually done under carefully controlled conditions to ensure correct temperature, humidity and time. This is very important for quality. The cooling stage lasts for about two hours which enables the loaves to be sliced easily. The bread is then wrapped (packaged) and stacked in crates ready for despatch.

4. WHEAT SUPPLY AND WET-MILL PATENT SEARCH

Wheat is the most important ingredient in bread, as the properties of the wheat grain determine the quality of the bread that can be made. This chapter explores all aspects of wheat supply in South Africa.

The wheat kernel or grain, known botanically as a caryopsis, is the fruit of the plant and is normally about 4-8mm long, depending on the variety. The kernel contains only one seed, which is not shed at maturity, in common with other grasses. The seed coat or pericarp consists of an epidermis and a hypodermis, which together are about 50µm thick. There is then a thin seed coat and the aleurone layer before the starch rich endosperm is reached.



Picture: Wheat kernel

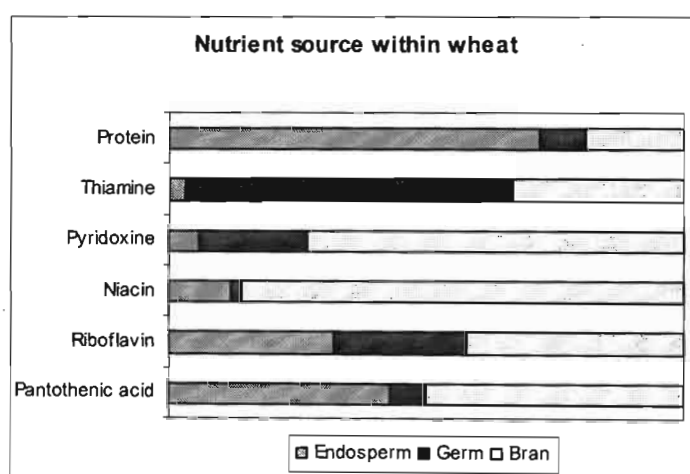
The endosperm is the material from which flour is made and comprises starch granules embedded in a matrix of proteins. The starch is present as lenticular granules varying in size from 10 to 50µm diameter and smaller spherical granules of 2-5µm¹ diameter which contain the proteins and lipids. The proteins consist of albumins,

¹ Sandstedt, R.M. 1946 Cereal Chemistry pg 337

globulins, gliadins and glutenins¹. The combination of gliadins and glutenins is referred to as the gluten complex. It is this gluten complex that makes wheat unique, in that it is elastic and allows baked products to hold gases and thus rise.

4.1. NUTRITIONAL COMPOSITION

A large portion of wheat's nutritional content is held in the outer layers (bran) which are removed during milling, only the endosperm being used for white flour. The table below gives a breakdown of nutrient sources within the wheat.



Graph: Nutrient source within wheat

4.2. CHARACTERISTICS OF WHEAT

There are four main characteristics of wheat. These are hardness, protein content, enzymatic activity (falling number) and hectalitre mass. Wheat is graded according to these variables. The falling number indicates the future **elasticity** of the dough; a high falling number is preferential for both the flour and the wet-mill processes.

¹ Cornell H.J., Hoveling A.W. 1998 Wheat Chemistry and Utilisation

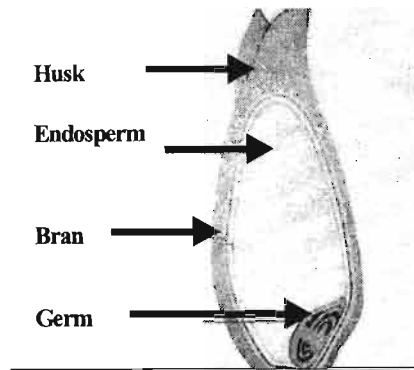


Diagram of wheat germ

The **density** of the wheat indicates the ratio of husk and bran to endosperm (flour). High density wheat would consist of small grains and thus a high ratio of husk to flour. A low density grain is preferable to make flour. The wet-mill process, however, can utilize almost any density flour; in fact, wheat which the flour industry regards as inferior, and therefore cheap, can be used successfully in the wet-mill process. A restriction does however occur when lower grade wheat is used for a plant bakery, when the dough then has to be strong. As described in Chapter 5, utility grade wheat did not survive the abuse tests of the plant bakery environment.

The **protein** level in wheat gives an indication of the hardness of the wheat (80% of the protein is concentrated in the husk & bran). Hard wheat is difficult to mill, thus a high protein wheat is undesirable for the flour industry. The wet-mill process eliminates the impact of hardness and, with more protein, the wheat is more nutritious. Undesirable and therefore cheap hard wheat (as far as the millers are concerned) is perfectly acceptable for the wet-mill process.

The table below summarises the importance of each of these characteristics.

Characteristic (common reference)	Range	Importance
Hardness (coarse/fine)	N/A	This refers to the brittleness of the wheat, and the ease with which bran is separated from the endosperm. This has a large impact on millability, but little impact on baking.
Protein content (strong/weak)	8%-18%	The quantity, quality and chemical structure of the protein is the most important characteristic in determining baking quality. There is no impact on millability. Protein is a function of growing conditions rather than biological strain.
Enzyme activity (falling number)		Alpha-amylase enzymes are catalysts in the gluten formation process (hydrolysis of glutenin). They do not affect milling, but have a substantial effect on baking. These enzymes form as the wheat matures, and too much causes dextrin to form rather than gluten.
Size (hectalitre mass)	66-79kg/Hl	The larger the grain of wheat, the more endosperm relative to its bran layer. Volumetric mass is used as an empirical measure of grain size, and relative endosperm content.

Table: The four characteristics of wheat¹

4.3. WHEAT STORAGE

In a hot humid environment, wheat can be stored for up to 5 weeks safely; in a dry environment wheat can be stored for up to 4 months². Thus the inbound logistic supply of wheat is easily manageable. This differs profoundly from the storage of flour. Due to the exposure to oxygen during the milling process, whole wheat flour can only be stored for a few days before the Free Fatty Acids (FFA) within the wheat germ become rancid³. It is due to this rancidity that brown bread is actually made from plain white flour with a small amount of reintroduced bran. The detrimental effects of the FFA containing wheat germ on the stability and performance of flour have long been known: in 1886 a patent was granted to Richard Smith of Staffordshire for a 'Patent

¹ Kent Technology of Cereals 4th ed, 1994, chapters 4-6

² General consensus, interviews with millers (Sasko personnel) and Master Baker Fred Knoetze 2001.

³ Blanshard, Frazier 'Chemistry and Physics of Baking' 1986 pg203

Germ Flour' where toasted wheat germ was combined with white flour to produce a more stable product which became the popular English 'Hovis' flour.

4.4. GRADING OF WHEAT

The price of wheat depends on its protein, elasticity and its density. The table below explains the commonly used grades of wheat. What is interesting in the table is an index relative to Canadian Red Wheat which is the datum for BPS. Canadian Red Wheat has an average protein content of 11.5 %, which is lower than the RSA average.

Density Protein	S (+79 kg/Hl)	1 (+76 kg/Hl)	2 (+74 kg/Hl)	UT1 (+72 kg/Hl)	UT2 (+70 kg/Hl)	KFG (+66 kg/Hl)
BP (+12%)	0	-20	-40	Utility grade	Utility grade	Feed grade
BS (10-11.9%)	-80	-100	-120			
BL (9-9.9%)	-140	-160	-180			

Table: Grading of wheat

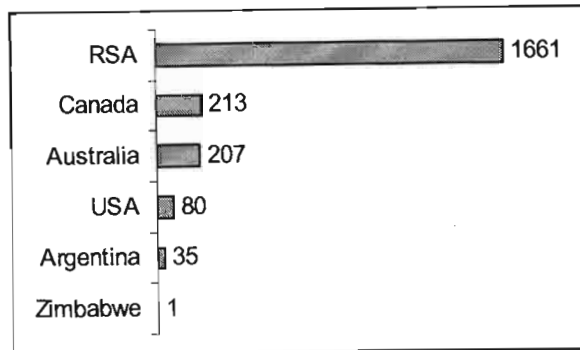
Example: Say BPS is priced at R1190/ton ex silo. Thus, wheat with an 80% BS1 content, and 20% BP1 would be priced at R1106 ($0.8 \times (1190 - 100) + 0.2 \times (1190 - 20)$) plus delivery (R75-150/ton). The protein content is so important that the protein level that can be expected throughout the harvest season is tracked.

Harvest time	Protein (%)
October-December	9 - 12
July-September	11.5 - 18
October-January	8 - 13.5
June-July	8 - 14.5
November-January	10 - 16

Table: Protein related to harvest

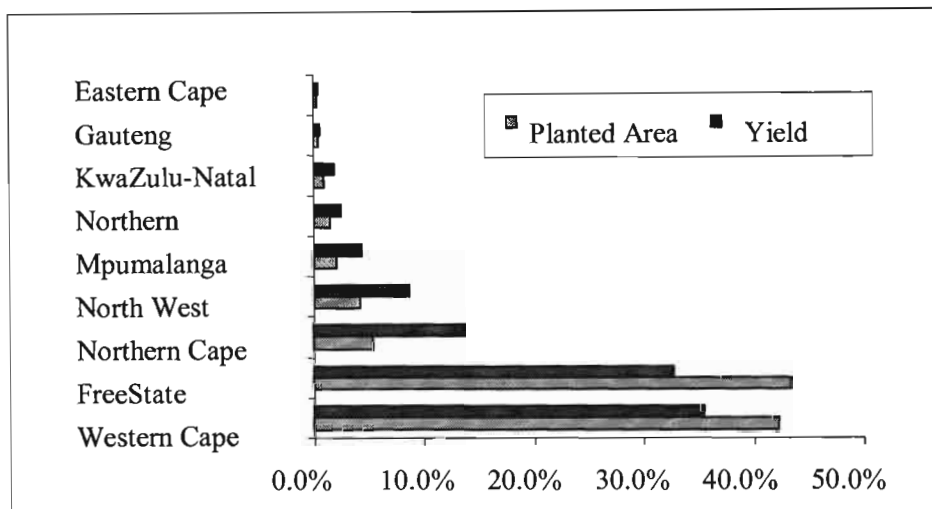
4.5. WHEAT SUPPLY

Wheat is available all year round, with our local supply bolstered by 35% from international sourcing. Currently 35% of wheat is sourced internationally from Zimbabwe (until 2001), Argentina, USA, Australia and Canada. Canada is the largest supplier as indicated in the graph below.



Graph: Sources of wheat¹

The remaining 1661 thousand tons of wheat (see chart above) are supplied by farms throughout South Africa. As can be see in the graph below, the Free State has the largest area under plantation; however, the Western Cape produces the highest yield.



Graph: Wheat production in South Africa

Wheat is harvested for 7 months of the year from November through to June, generating a total crop of 1.8 million tons, of which 1.6 is considered bread grade. The crops grown in the Free State and Western Cape are referred to as 'Natural Rainfall'

¹ Compiled from FAO.com trade statistics 00846547 1998/9

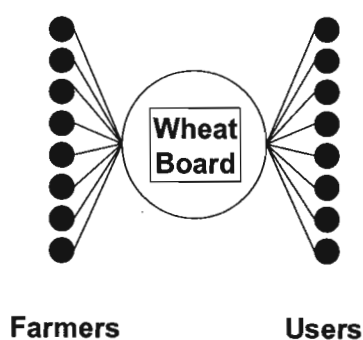
wheat, whereas the wheat from the Northern Province is 'irrigation' wheat. Currently 65% of the local demand of 2.5 million tons of bread grade wheat is supplied from within SA. There is optimism that cultivar development in the Western Cape will ensure that South Africa is self sufficient within 2 years.

Area	Type	J	F	M	A	M	J	J	A	S	O	N	D	
RSA		h				h	h	h				h	h	h
Cape	Winter wheat/Winter rainfall						p	p				h	h	h
FreeState	Winter wheat/Summer rainfall	h			p	p	p	p				h	h	h
Transvaal	Spring wheat/Summer rainfall	p	p			h	h	h						
Natal	Summer wheat/Irrigated	p	p			h	h							
Canada				p	p			h	h	h				
Australia							p	p				h	h	h
USA		p	p			h	h	h	h					p
Argentina		h						p	p			h	h	

p=plant, h=harvest

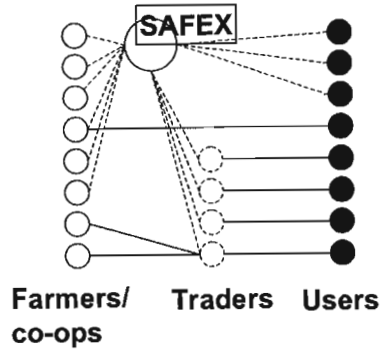
Table: Plant / Harvest cycle of wheat in SA¹

Prior to the 1997 deregulation, wheat could only be bought and sold through the Wheat Board as per the schematic below. Prices were fixed and farmers were guaranteed to be able to sell their harvest; the Wheat Board took all the risk including that of high import prices. The Wheat Board governed all grading and quality issues.



Since the 1997 deregulation wheat can be bought through a number of bodies e.g., direct from farmers, through co-ops, from traders or even directly imported.

¹ Source: SA Chamber of Milling



As can be seen in the schematic above, there is much greater flexibility in purchasing wheat. A futures market (SAFEX) has been developed to help reduce risks. Prices are market related - import parity, location, quality and other factors influence local prices. Standards are regulated in consultation with the entire industry.

4.6. THE MILLING OF WHEAT

Wheat is converted into flour by the following standard processes: preparation, cleaning, milling and bolting, and packing. The wheat is harvested and then transported to massive bulk storage silos. At this stage a quality control check is performed to measure the protein and bulk density parameters i.e.: the grade of wheat. The four milling processes are described in more detail below.

4.6.1. Cleaning of Wheat

The wheat then has to be cleaned to remove biological, wood and metal contaminants. The wheat is cleaned through a first separator which aspirates off any loose husk and allows fines (such as sand and dirt) to drop through. It then passes through a de-stoner which normally uses a vibrating deck to gravity separate off all heavier objects. A second, finer, disk separator is then used followed by a scourer which removes much of the outer layer before the first 'crack' or milling step. Magnets are usually used in-line throughout this process to remove any metallic objects that might have been picked up during harvesting. It is not unusual to find bolts and other small metal parts in harvested cereals.

4.6.2. Milling of Wheat

Milling is accomplished by one of four systems:

- Low milling
- Hungarian system, or high milling
- Roller milling
- Disintegrator milling

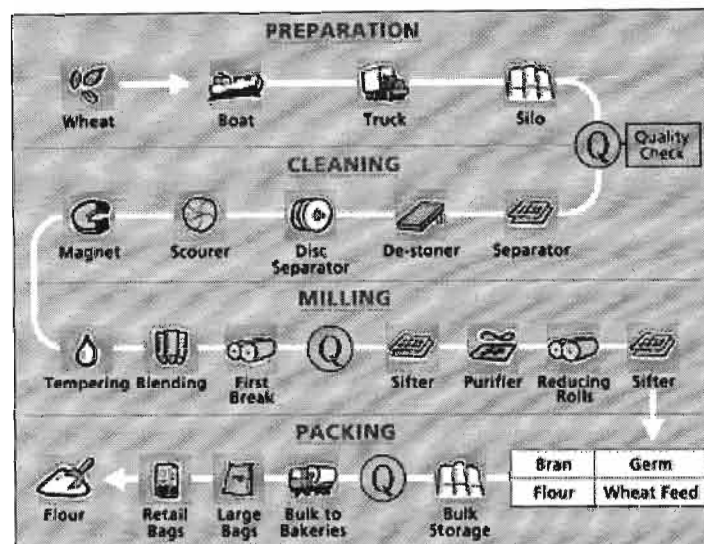


Figure: Milling process flow¹

Low Milling Process: In this process, grooved stones are employed for milling. The stones are enclosed in a metal case, and provision is made within the case for passage of air to prevent wheat from becoming overheated. The lower stone is permanently fixed and the upper stone is balanced above it, so that when it rotates the sharp edges of grooves meet each other and operate like a pair of scissors. This is, in effect, a single step milling process.

High Milling Process: In this process a series of grooved stones is employed so that the wheat is initially only bruised, followed by a progressive breakdown in each subsequent stone set. This process is applicable only to the hardest of wheats, and has been partially supplanted by roller-milling.

¹ Source: The Millers Hand Book, British Master Baker's Guild's training manual.

Roller-milling Process: Here, the wheat is subjected to the action of a pair of steel or chilled-iron horizontal rollers with toothed surfaces. They revolve in opposite directions, at different speeds, and have a shearing and cutting action. Porcelain rollers, with rough surfaces, are sometimes employed. In this system, milling is accomplished by cutting rather than crushing. A typical roller milling plant set up is shown in the sketch below:

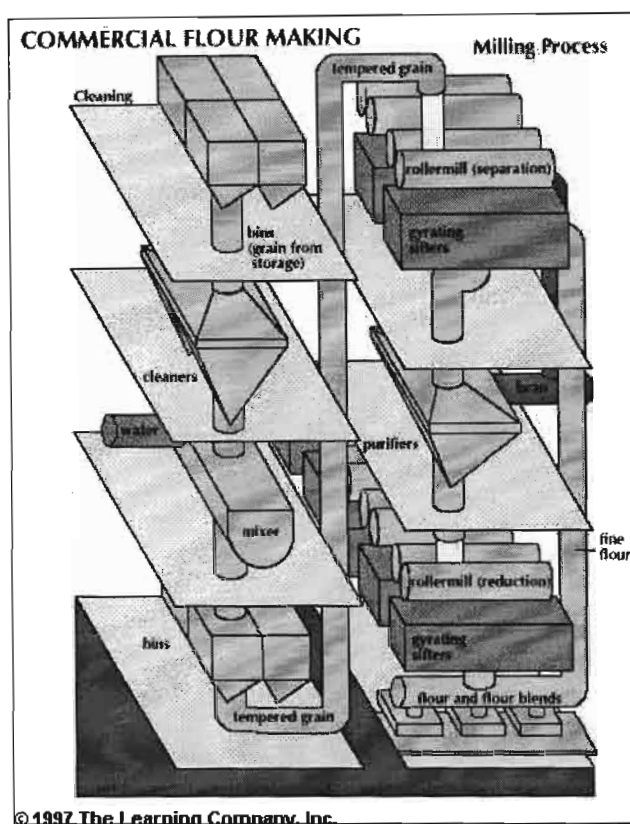


Figure: Roller milling plant lay out¹

Disintegrator Milling Process: This consists of a pair of circular metal disks, set face to face, studded with circles of projecting bars so arranged that circles of bars on one disk alternate with those of the other. The disks are mounted on the same centre, and so closely set to one another that projecting bars of one disk come quite close to the plane surface of the other. They are enclosed by an external casing. The disks are rapidly rotated in opposite directions and the grain is almost instantaneously reduced to a powder.

¹ Source: The Learning Company, 1997

Although the nutritional value of wheat is great, it is very difficult to retain this value during the milling process. The graph below shows how the extraction efficiency determines the quality of vitamins and minerals that remain in the product.

One of the major advantages of the wet-milling process is that there is no extraction and thus the final product is nutritionally superior. (100% is the undamaged whole wheat kernel. Flour extraction, on the other hand, is about 80 %.)

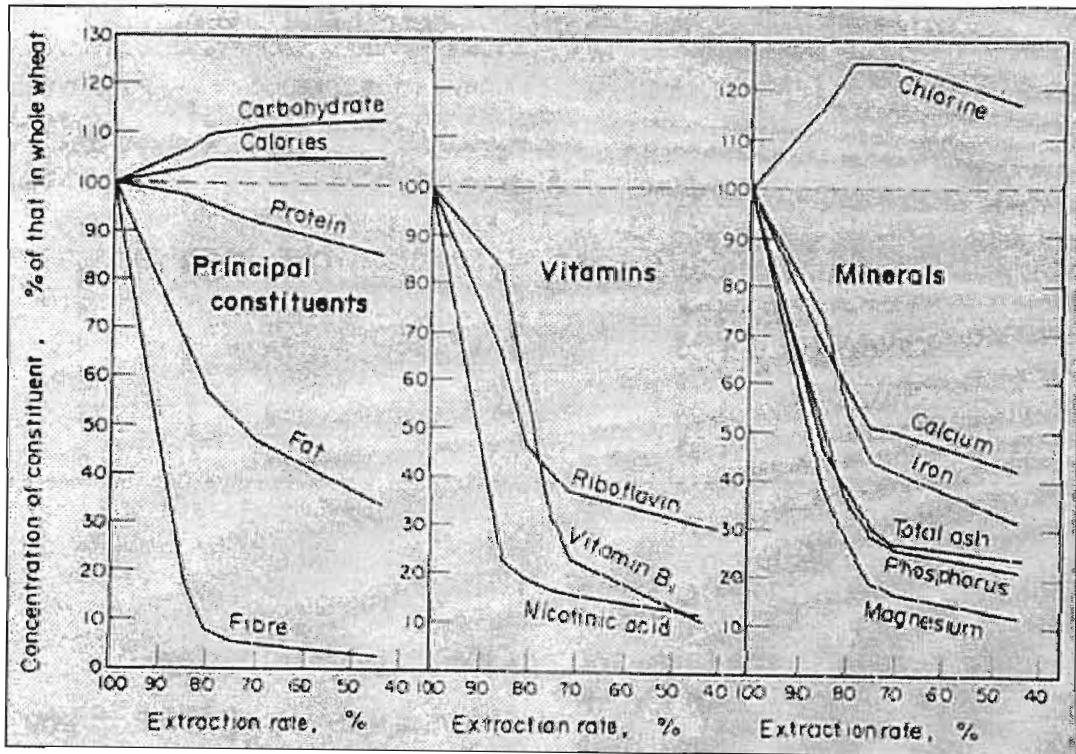
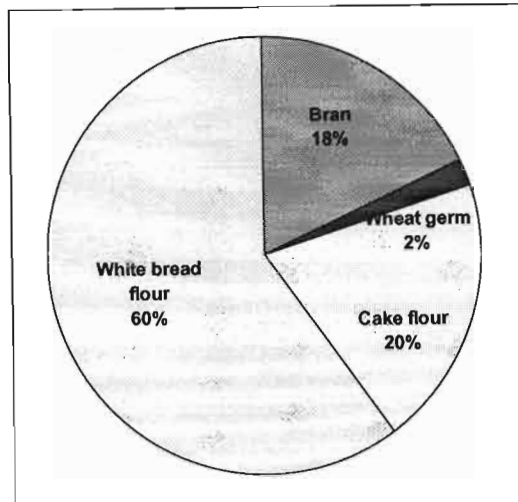


Figure: Nutrition vs. % Extraction¹

It is interesting to note the milling extraction of wheat into its component parts as depicted in the pie chart below. Bran is seen in the bread business as waste. Very little of it is converted into cereal products and the majority is sold as animal feed at R0.40/kg. Excess bran is even dumped.

¹ Source: Kent Technology of Cereals 4th ed pg 288



Graph: Breakdown of milling products

Wheat germ is a soft, sweet and oily yellow flake with high nutritional content. It is not usually packed and sold because it is extremely difficult to handle, so it is mixed with bran and sold as animal feed. There are smaller, capital-intensive establishments that toast the bran giving it a shelf life and better packing properties. White bread flour is off-white very fine flour, and when packed it is sold for R2.20. Bran is added back to bread flour at 13% to yield brown bread flour sold at R1.9/kg. Cake flour is the premium, profit making product sold at about R2.4/kg.

4.7. PATENT SEARCH: WET-MILLING

A thorough patent search was undertaken just in case wet-milling as a process step for making bread already existed. However, it was discovered that wet-milling is a technique that exists only to extract starch or gluten. The processes and equipment used in existing wet-mill facilities had to be examined in case any of them were relevant, but they were of no relevance whatsoever, confirming that the process equipment that is the focus of the second part of this thesis is indeed truly original.

Wet-milling differs fundamentally from dry milling in that its aim (up until now) has been to extract starch (initially) and gluten (as extraction methods improved). It was first described by Marcus Porcius Cato (234-149 BC) as a process in which cleaned wheat was soaked in twice its weight of water, enclosed in a cloth, slurried and the starch

milk pressed out. The residue of gluten, bran and germ would have been discarded or used as animal feed¹.

All wet-milling involves the complete dissociation of the endosperm cell contents with the release of the starch granules from the protein network in which they are enclosed. Wheat and maize are the two cereals most widely used in wet-milling to produce starch. All wet processes for the manufacture of starch and gluten involve the following steps: extraction of crude starch and gluten, purifying, concentrating and drying. Most wet processes now start with milled white flour to get better quality (higher purity) gluten.

There are three broad categories of wet-mill processes using flour as a basis:

- Martin Process: dough is kneaded under water sprays. The gluten agglomerates, and the starch is washed out. This process was optimised in the Far-Mar-Co flour process (US Pat. No. 3979375)
- Batter process: a flour-water batter is dispersed in extra water so that the gluten breaks down into small curds. The gluten is separated by screening. The Alfa-Laval/Rasio process and Koninklijke Scholten-Honig (British Patent 1596742) process are both refinements of the batter process.
- Alkali process: flour is suspended in an alkaline solution (e.g.: sodium hydroxide) in which the protein disperses. Starch is removed by tabling and centrifuging, and the protein is precipitated out. This protein is non vital (denatured). The 1966 Canadian process is a refinement of this process²

Wet-milling has also developed using wheat as the base raw material. The wet grain is coarsely milled, slurried with water and screened to remove the bran and germ. The heavy starch granules are separated by centrifuging.

Two processes are well documented:

¹ May, J.B. 1987 Wet-milling: Process and Products.

² Kent, N.L. Technology of cereals 4th edition 1994 pg 259-261

- Pillsbury Process (British Patent No 1357669): Grain is steeped in acid under vacuum to remove any air pockets that might aid the development of micro-organisms.
- Far-Mar-Co wheat process (US Patent no 4201708): Wheat is soaked and flaked. The flakes are disintegrated, and the resulting bran-germ and endosperm particles hydrated, to form a sticky mass which is tumbled in water to separate and recover vital gluten and starch components. It was this equipment which was of interest, but further research revealed nothing that was of benefit to this thesis.

Some of the most common uses for maize and wheat starch include paper manufacture, textiles, adhesives and packaged foods. Starch is often further processed to make modified starch (such as starch esters used as thickening agents), sweeteners and alcohol (ethanol produced from maize starch is blended with gasoline in which it acts as an octane enhancer for unleaded fuels).

5. PRODUCT DESIGN; MACHINE AND PROCESS CONSTRAINTS

In Chapter 2, consumer research indicated that the product met particular consumer requirements of nutrition and taste. Chapter 3 explained the industrial manufacturing process in which such a product would have to be produced (the 'customer' of the process) and Chapter 4 looked at the supply of wheat. Chapter 4 also completed a patent search on the wet-mill process to ensure that the idea was indeed original. The continued project could then be split into two product development phases. The first would be to finalise the product along a number of key customer and consumer specified design criteria. The second phase would be to define process variables associated with the wet-mill production. These would then form important design or constraint criteria for the design of the wet-mill equipment.

Sections 1 and 2 of this chapter complete phase one. The first step was to verify that the patented recipe worked. This was followed by a series of optimisations. The initial objective was to optimise the recipe costs in a lab environment. The second was to strengthen the recipe to make bread that would sustain the normal abuse of an industrial cumulative conveyor system. The results presented here span over 8 months of work in a laboratory. The process was highly iterative; at each iteration the consumer requirements of taste and functionality, and the customer requirements of 'fit' within a plant bakery, had to be met.

Sections 3 to 7 describe a series of experiments that measure various process variables, and, where possible, use this knowledge to optimise the process. The impact of process time and the corresponding coarseness of grain on the resultant bread quality were investigated, along with other experiments such as bowl speed versus temperature gain, and soak time versus softening of grain. The robustness of the recipe was tested using various grades of wheat. Trials were completed to measure the maximum time that the process could be interrupted and the dough stored. Lastly the mechanical loading on the blade was investigated to provide design information for the machine that would have to be designed. This phase of the project lasted 6 months.

5.1. CONFIRM PATENT RECIPE

Ingredient	Quantity (g)	Percentage (%)
Yeast	90	3
Sugar	150	5
Vital wheat gluten	90	3
Vegecap (Breadcap) fat	60	2
Vinegar	60	2
Salt	30	1
Ascorbic Acid	0.3	0.01
Water	1800	60
Wheat	3000	1000

Table: September standard recipe

Step 1	Weigh 1750g water.
Step 2	Dissolve salt and ascorbic acid in water.
Step 3	Weigh 3 kg wheat.
Step 4	Put wheat in salted water and soak for 12 hours at room temperature.
Step 5	Put soaked wheat into refrigerator for 12 hours.
Step 6	Weigh all other ingredients (yeast, sugar, gluten, fat, vinegar).
Step 7	Put cold soaked wheat into the bowl cutter.
Step 8	Start the bowl cutter at low speed.
Step 9	Add ingredients except yeast. Mix for a total of 1 minute.
Step 10	Run the machine at fast speed for 5 minutes.
Step 11	Stop machine. Scrape what has accumulated in the lid back into the bowl.
Step 12	Close the lid and start the machine at fast for 2 minutes. The final dough temperature should be between 25°C and 26°C. Allow to cool if required.
Step 13	Remove the dough and put it in the dough mixer.
Step 14	Mix yeast with 50g warm water (1800g minus the 1750g used in the soak) and convert it into a thick cream.
Step 15	Add the yeast to the dough in the dough mixer.
Step 16	Start the mixer at low speed for 1 minute, then mix for 7 minutes at medium speed.
Step 17	Take the dough out. Cut and weigh off 800g pieces.
Step 18	Dust the table with a little flour to prevent the dough from sticking.
Step 19	Roll dough and fold. Tuck in sides to form a loaf and place in a greased bread tin.
Step 20	Put the bread in a prover for 1 hour or until the dough has risen above the rim of the bread tin.
Step 21	Bake at 225°C for 20 – 25 minutes.

Table: September standard methodology:

This recipe was tested on a series of 3 kg batches and it worked. It was however very expensive and so required a series of tests to see if some of the ingredients could be eliminated. The first two optimisations utilised the bowl cutter as it was designed, and can be seen in the picture below. The next two optimisations were performed in the 50kg 'test' vertical wet-mill machine. The evolution of this machine is described in detail, in Chapters 6 and 11.



Picture: 20 Litre bowl cutter

5.2. RECIPE INGREDIENT OPTIMISATION

5.2.1. First Laboratory Optimisation

The September Standard recipe was (recipe 5c on table below) more expensive per loaf than the plant bakeries. Therefore, the first set of laboratory optimisations were aimed at reducing the expensive addition of gluten as well as other ingredients. The tabulated summary of this series of tests is presented in the table below (First Laboratory Optimisation). Each bake changed a single variable which is indicated in all the tables below in red. Some of the actual loaves in the first series of optimisations can be seen in the picture below.

The consequence of reducing gluten without any enzyme was disastrous – a small brick was produced! The sugar was reduced from 5% to 3% without any impact on taste. In bake 6 the level of gluten was decreased with the simultaneous addition of 2000B – this was successful.

When mixtures of other enzymes were added the dough became a sticky nightmare which was impossible to work with. It became obvious that it was necessary to call in a baking expert!

Ingredient	PLANT BAKERY			0- SEPTEMBER STANDARD			1A. DROP SUGAR			1B. DROP GLUTIN			
	Unit cost	%	R/loaf	%	kg	R/loaf	%	kg	R/loaf	%	kg	R/loaf	kg
Flour	1.82	100.0%	0.86	100.0%	0.48	0.63	0.0%	0.48	100.0%	0.0%	0.48	0.86	0.86
Wheat	1.32	0.0%	-	0.0%	0.48	0.63	100.0%	0.48	100.0%	0.0%	0.48	0.63	0.63
Sugar	3.00	1.0%	0.01	1.0%	0.02	0.07	0.0%	0.01	0.04	0.0%	0.01	0.04	0.04
Salt	0.80	2.0%	0.01	1.0%	0.00	0.00	0.0%	0.00	0.00	1.0%	0.00	0.00	0.00
Fat	6.25	0.3%	0.00	2.0%	0.01	0.06	0.0%	0.01	0.06	2.0%	0.01	0.06	0.06
SuperMA2000	185.00	0.0100%	0.00	0.0000%	-	-	0.0000%	-	-	0.0000%	-	-	-
LipoPan	500.00	0.0000%	-	0.0000%	-	-	0.0000%	-	-	0.0000%	-	-	-
Admul Datum	29.37	0.0000%	-	0.0000%	-	-	0.0000%	-	-	0.0000%	-	-	-
Ascorbic acid	54.09	0.0100%	0.00	0.0100%	0.00	0.00	0.1000%	0.00	0.03	0.0100%	0.00	0.00	0.00
SSL	12.75	0.2%	0.00	0.0%	-	-	0.0%	-	-	0.0%	-	-	0.01
CaPropanate	10.00	0.3%	0.00	0.5%	-	-	0.0%	-	-	0.0%	-	-	0.01
Soya	2.20	1.0%	0.00	0.0%	-	-	0.0%	-	-	0.0%	-	-	0.01
Yeast	6.20	2.2%	0.01	3.0%	0.01	0.09	0.0%	0.01	0.09	3.0%	0.01	0.09	0.01
Vitamins	13.00	0.2%	0.00	0.0%	-	-	0.0%	-	-	0.0%	-	-	0.01
Gluten	13.00	0.0%	-	3.0%	0.01	0.19	0.0%	0.01	0.19	3.0%	0.01	0.19	0.12
Vinegar	1.00	0.0%	-	2.0%	0.01	0.01	2.0%	0.01	0.01	2.0%	0.01	0.01	0.01
Total			1.00			1.05			1.05			1.05	0.96
													0.04

Ingredient	2. DROP YEAST			3. DROP FAT for SuperMA			4. Drop fat for SMA & LipoPan			5. Replace gluten with 2000B			
	Unit cost	%	R/loaf	%	kg	R/loaf	%	kg	R/loaf	%	kg	R/loaf	kg
Flour	1.82	0.0%	-	0.0%	0.48	0.86	0.0%	0.48	0.86	0.0%	0.48	0.86	0.86
Wheat	1.32	100.0%	0.63	100.0%	0.63	(0.63)	100.0%	0.48	0.63	100.0%	0.48	0.63	0.63
Sugar	3.00	0.0%	0.04	3.0%	0.01	0.04	0.0%	0.01	0.04	0.0%	0.01	0.04	0.04
Salt	0.80	1.0%	0.00	1.0%	0.00	0.00	1.0%	0.00	0.00	1.0%	0.00	0.00	0.00
Fat	6.25	2.0%	0.01	0.0%	0.00	0.02	1.0%	0.00	0.02	2.0%	0.01	0.06	0.05
SuperMA2000	185.00	0.0000%	-	0.0000%	-	-	0.0000%	-	-	0.0000%	-	-	-
LipoPan	500.00	0.0000%	-	0.0000%	-	-	0.0000%	-	-	0.0000%	-	-	-
Admul Datum	29.37	0.0000%	-	0.0000%	-	-	0.0000%	-	-	0.0000%	-	-	-
Ascorbic acid	54.09	0.0100%	0.00	0.0100%	0.00	0.00	0.1000%	0.00	0.00	0.1000%	0.00	0.00	0.00
SSL	12.75	0.0%	0.00	0.0%	-	-	0.0%	-	-	0.0%	-	-	0.01
CaPropanate	10.00	0.0%	0.00	0.0%	-	-	0.0%	-	-	0.0%	-	-	0.01
Soya	2.20	0.0%	0.00	0.0%	-	-	0.0%	-	-	0.0%	-	-	0.01
Yeast	6.20	0.0%	0.00	3.0%	0.01	0.09	0.0%	0.01	0.09	3.0%	0.01	0.09	0.01
Vitamins	13.00	0.0%	0.00	0.0%	-	-	0.0%	-	-	0.0%	-	-	0.01
Gluten	13.00	3.0%	0.01	3.0%	0.01	0.19	3.0%	0.01	0.19	3.0%	0.01	0.12	0.12
Vinegar	1.00	2.0%	0.01	2.0%	0.01	0.01	2.0%	0.01	0.01	2.0%	0.01	0.01	0.01
Total			1.00			1.02			1.04			1.05	0.97
													0.03

Table: Summary of first laboratory optimisation

It is important to note that at this stage 800g of dough was being used to make a loaf that would compare in size with a standard government loaf of 700g. Thus at this point in the project the cost advantages of using whole wheat instead of flour were far outweighed by the costs of producing a decent loaf.



Picture: September recipe optimisation trials

5.2.2. Second Lab Optimisation

Loaf weight		PLANT BAKERY				CONTROL: October				1: DROP VINEGAR			
Unit cost	%	kg	R/loaf	%	kg	R/loaf	Saving	%	kg	R/loaf	Saving		
Flour	1.86	100%	0.46	0.86	0.0%	-	0.86	0.0%	-	-	0.86		
Wheat	1.32	0.0%	-	-	100.0%	0.48	0.63	(0.63)	100.0%	0.48	0.63	(0.63)	
Sugar	3.00	1.0%	0.00	0.01	3.0%	0.01	0.04	(0.03)	3.0%	0.01	0.04	(0.03)	
Salt	0.60	2.0%	0.01	0.01	2.0%	0.01	0.01	(0.00)	2.0%	0.01	0.01	(0.00)	
Fat	6.25	0.3%	0.00	0.01	2.0%	0.01	0.06	(0.05)	2.0%	0.01	0.06	(0.05)	
SuperMA/2000	185.00	0.0100%	0.00	0.01	0.0000%	-	-	0.01	0.0000%	-	-	0.01	
LipoPan	500.00	0.0000%	-	-	0.0000%	-	-	-	0.0000%	-	-	-	
Admul Datum	29.37	0.0000%	-	-	0.0000%	-	-	-	0.0000%	-	-	-	
Ascorbic acid	54.00	0.0100%	0.00	0.00	0.0100%	0.00	0.00	(0.00)	0.0100%	0.00	0.00	(0.00)	
SSL	12.75	0.2%	0.00	0.01	0.0%	-	-	0.01	0.0%	-	-	0.01	
CaPropanate	10.00	0.3%	0.00	0.01	0.0%	-	-	0.01	0.0%	-	-	0.01	
Soya	2.20	1.0%	0.00	0.01	0.0%	-	-	0.01	0.0%	-	-	0.01	
Yeast	6.20	2.2%	0.01	0.06	3.0%	0.01	0.09	(0.03)	3.0%	0.01	0.09	(0.03)	
Vitamins	13.00	0.2%	0.00	0.01	0.0%	-	-	0.01	0.0%	-	-	0.01	
Gluten	13.00	0.0%	-	-	2.0%	0.01	0.12	(0.12)	2.0%	0.01	0.12	(0.12)	
Vinegar	1.00	0.0%	-	-	2.0%	0.01	0.01	(0.01)	-	-	-	-	
Total				1.00			0.96	0.04			0.96	0.05	

Unit cost	2: DROP SUGAR				3: DROP GLUTIN + 2000B				4: DROP ALL				
	%	kg	R/loaf	Saving	%	kg	R/loaf	Saving	%	kg	R/loaf	Saving	
Flour	1.86	0.0%	-	-	0.86	0.0%	-	-	0.86	0.0%	-	-	0.86
Wheat	1.32	100.0%	0.48	0.63	(0.63)	100.0%	0.48	0.63	(0.63)	100.0%	0.48	0.63	(0.63)
Sugar	3.00	-	0.00	0.01	(0.00)	3.0%	0.01	0.04	(0.03)	-	0.00	0.01	(0.00)
Salt	0.60	2.0%	0.01	0.01	(0.00)	2.0%	0.01	0.01	(0.00)	2.0%	0.01	0.01	(0.00)
Fat	6.25	2.0%	0.01	0.06	(0.05)	2.0%	0.01	0.06	(0.05)	2.0%	0.01	0.06	(0.05)
SuperMA/2000	185.00	0.0000%	-	-	0.01	-	0.00	0.01	(0.00)	-	0.00	0.01	(0.00)
LipoPan	500.00	0.0000%	-	-	-	-	-	-	-	-	-	-	-
Admul Datum	29.37	0.0000%	-	-	-	-	-	-	-	-	-	-	-
Ascorbic acid	54.00	0.0100%	0.00	0.00	(0.00)	0.0100%	0.00	0.00	(0.00)	0.0100%	0.00	0.00	(0.00)
SSL	12.75	0.0%	-	-	0.01	0.0%	-	-	0.01	0.0%	-	-	0.01
CaPropanate	10.00	0.0%	-	-	0.01	0.0%	-	-	0.01	0.0%	-	-	0.01
Soya	2.20	0.0%	-	-	0.01	0.0%	-	-	0.01	0.0%	-	-	0.01
Yeast	6.20	3.0%	0.01	0.09	(0.03)	3.0%	0.01	0.09	(0.03)	3.0%	0.01	0.09	(0.03)
Vitamins	13.00	0.0%	-	-	0.01	0.0%	-	-	0.01	0.0%	-	-	0.01
Gluten	13.00	2.0%	0.01	0.12	(0.12)	-	-	-	-	-	-	-	-
Vinegar	1.00	2.0%	0.01	0.01	(0.01)	2.0%	0.01	0.01	(0.01)	-	-	-	-
Total				0.93	0.07			0.85	0.15			0.81	0.19

Table: Summary of second laboratory optimisation

A retired senior baker and ex-plant manager, Mr Fred Knoetze, of the Pioneer Food Group which produces the Sasko bread range, agreed to help: Fred was able to provide insight on the 'art' of bread making, which, as described in the previous chapters still somewhat defies pure science. The first change was that the batch size was increased to 15kg which allowed for better mixing in the dough mixer. During the second recipe optimisation period, the soak time was also being optimised. In order to minimize activity in the soak, 2% salt was added in the soak water. At 3% sugar, the extra salt could not be detected in the baked bread; however, at 1% sugar, a slightly salty aftertaste could be detected. The major difference in this series of bakes was the increased mixing time. The expert baker commented that the dough was underdeveloped at the September Standard mixing times and the dough mixer run was extended to 15 minutes (or until the dough was fully developed, using a dough window¹). The process was also modified to let the dough stand for 10 minutes before it was rolled into the baking tin and proved. These process modifications enabled the elimination of the extra gluten. The natural gluten within the dough was being forced to work more efficiently. The vinegar was also eliminated. At the beginning of these trials 800g of dough was still being used, but towards the end of the series the dough was lifting the lid off the pans. This indicated that for the next series of trials the dough could be scaled down. See table: Second Lab Optimisation above, for the summary of this series of bakes.

5.2.3. Third Laboratory Optimisation

	Unit cost	CONTROL: November				1: DROP SUGAR				2: CHANGE TO OIL			
		%	kg	R/loaf	Saving	%	kg	R/loaf	Saving	%	kg	R/loaf	Saving
Flour	1.86	0.0%	-	-	0.86	0.0%	-	-	0.86	0.0%	-	-	0.86
Wheat	1.32	100.0%	0.44	0.58	(0.58)	100.0%	0.44	0.58	(0.58)	100.0%	0.44	0.58	(0.58)
Sugar	3.00	3.0%	0.01	0.04	(0.03)	0.0%	0.00	0.01	0.00	3.0%	0.01	0.04	(0.03)
Salt	0.60	1.0%	0.00	0.00	0.00	1.0%	0.00	0.00	0.00	1.0%	0.00	0.00	0.00
Fat	6.25	2.0%	0.01	0.06	(0.05)	2.0%	0.01	0.06	(0.05)	0.0%	0.01	0.05	(0.05)
SuperMA/2000	185.00	0.0100%	0.00	0.01	0.00	0.0100%	0.00	0.01	0.00	0.0100%	0.00	0.01	0.00
LipoPan	500.00	0.0000%	-	-	-	0.0000%	-	-	-	0.0000%	-	-	-
Admul Datum	29.37	0.0000%	-	-	-	0.0000%	-	-	-	0.0000%	-	-	-
Ascorbic acid	54.00	0.0100%	0.00	0.00	0.00	0.0100%	0.00	0.00	0.00	0.0100%	0.00	0.00	0.00
SSL	12.75	0.0%	-	0.01	-	0.0%	-	0.01	-	0.0%	-	0.01	-
CaPropanate	10.00	0.0%	-	0.01	-	0.0%	-	0.01	-	0.0%	-	0.01	-
Soya	2.20	0.0%	-	0.01	-	0.0%	-	0.01	-	0.0%	-	0.01	-
yeast	6.20	3.0%	0.01	0.08	(0.02)	3.0%	0.01	0.08	(0.02)	3.0%	0.01	0.08	(0.02)
/Vitamins	13.00	0.0%	-	0.01	-	0.0%	-	0.01	-	0.0%	-	0.01	-
Gluten	13.00	0.0%	-	-	-	0.0%	-	-	-	0.0%	-	-	-
/inegar	1.00	0.0%	-	-	-	0.0%	-	-	-	0.0%	-	-	-
Total				0.77	0.23			0.75	0.26			0.77	0.23

¹ A 'dough window' is formed by extending a piece of dough into a very thin film. If the dough is fully developed the film becomes almost translucent. If the dough is not developed the dough breaks and does not even form a thin film.

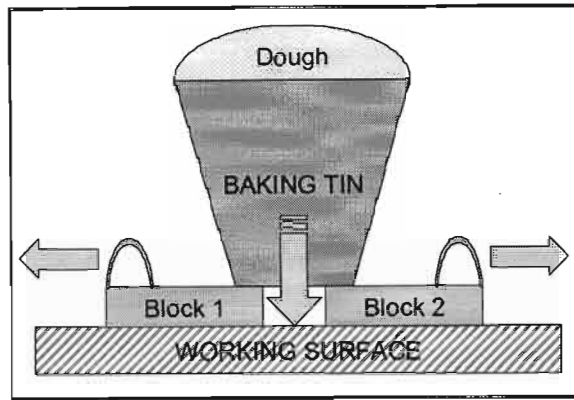
	Unit cost	3: DROP OIL				4: DROP YEAST				5: ALL				
		%	kg	R/loaf	Saving	%	kg	R/loaf	Saving	%	kg	R/loaf	Saving	
Flour	1.86	0.0%	-	-	0.86	0.0%	-	-	0.86	0.0%	-	-	0.86	
Wheat	1.32	100.0%	0.44	0.58	(0.58)	100.0%	0.44	0.58	(0.58)	100.0%	0.44	0.58	(0.58)	
Sugar	3.00	3.0%	0.01	0.04	(0.03)	3.0%	0.01	0.04	(0.03)	1.0%	0.00	0.01	0.00	
Salt	0.60	1.0%	0.00	0.00	0.00	1.0%	0.00	0.00	0.00	1.0%	0.00	0.00	0.00	
Fat	6.25		0.00	0.03	(0.02)	2.0%	0.01	0.05	(0.05)		0.00	0.03	(0.02)	
SuperMA/2000	185.00	0.0100%	0.00	0.01	0.00	0.0100%	0.00	0.01	0.00	0.0100%	0.00	0.01	0.00	
LipoPan	500.00	0.0000%	-	-	-	0.0000%	-	-	-	0.0000%	-	-	-	
Admul Datum	29.37	0.0000%	-	-	-	0.0000%	-	-	-	0.0000%	-	-	-	
Ascorbic acid	54.00	0.0100%	0.00	0.00	0.00	0.0100%	0.00	0.00	0.00	0.0100%	0.00	0.00	0.00	
SSL	12.75	0.0%	-	-	0.01	0.0%	-	-	0.01	0.0%	-	-	0.01	
CaPropanate	10.00	0.0%	-	-	0.01	0.0%	-	-	0.01	0.0%	-	-	0.01	
Soya	2.20	0.0%	-	-	0.01	0.0%	-	-	0.01	0.0%	-	-	0.01	
Yeast	6.20	3.0%	0.01	0.08	(0.02)	2.0%	0.01	0.05	0.01	1.0%	0.01	0.05	0.01	
Vitamins	13.00	0.0%	-	-	0.01	0.0%	-	-	0.01	0.0%	-	-	0.01	
Gluten	13.00	0.0%	-	-	-	0.0%	-	-	-	0.0%	-	-	-	
Vinegar	1.00	0.0%	-	-	-	0.0%	-	-	-	0.0%	-	-	-	
Total					0.74				0.26				0.69	0.31

Table: Summary of third laboratory optimisation

During the third series of recipe optimisation tests, small changes were made to the type and quantity of the ingredients (switched to oil instead of hard fat, reduced yeast from 3% to 2%, reduced oil from 2% to 1% and reduced sugar from 3% to 1% with no taste implication). However the batch size was increased from 15kg to 50kg. This required a period of learning to observe how long the dough took to develop in the new, larger mixer. The dough was successfully scaled at 757g to produce a 700g loaf. The economics of the process suddenly looked more promising with a 31% recipe costs saving as can be seen in the summary table: Third Laboratory Optimisation above.

5.2.4. Plant Recipe Optimisation

The plant recipe optimisation was a continuation of the 50kg batch size with 'abuse' tests performed on the proved dough. The abuse test is a repeated controlled drop of the baking tin containing the proved dough. This is achieved by pulling apart two blocks upon which the baking tin rests. This ensures that the dropped height remains at a controlled standard. The dough's strength is determined by measuring how far the dough drops (or collapses) after the drop. If the dough is not affected after three drops, then it is the industry standard to accept that dough as strong enough to perform in an industrial bakery. A sketch of the abuse test is included below:



Sketch: Abuse test configuration

The dough was not strong enough initially and the percentage of ascorbic acid had to be increased to 0.02% (200ppm) which ensured that the dough became immune to the abuse. A second modification was required so that the recipe could conform to the industrial standard of proving within 50 minutes, rather than the 60 to 65 that was achieved with the December Standard recipe. Yeast was increased from 2% to 2.5% and SSL was added, which not only helped proving but also aided the robustness of the dough. The dough was still successfully weighed off at the 757g November standard.

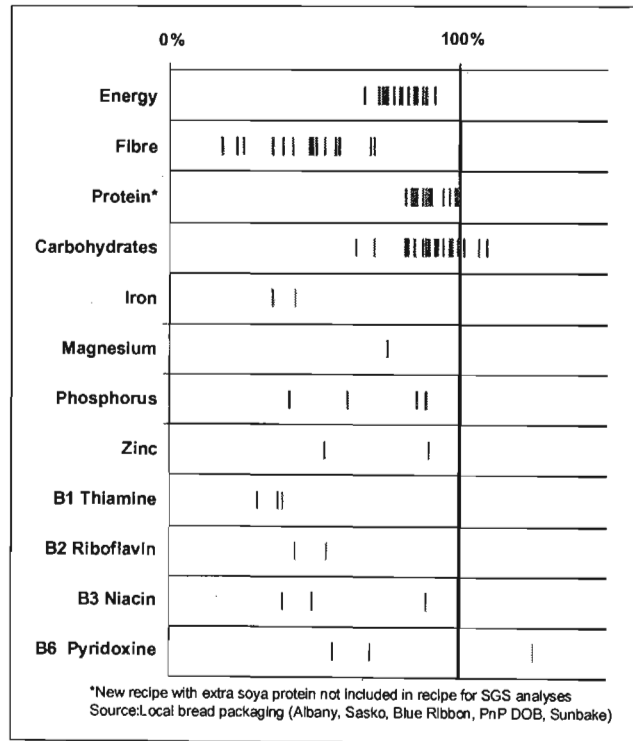
	Unit cost	PLANT BAKERY				CONTROL DECEMBER				1: INCREASE YEAST				2: ADD SSL					
		%	kg	R/loaf	Saving	%	kg	R/loaf	Saving	%	kg	R/loaf	Saving	%	kg	R/loaf	Saving		
Flour	1.86	100%	0.46	0.86	0.0%	-	-	0.86	0.0%	-	-	0.86	0.0%	-	-	0.86	0.0%	-	0.86
Wheat	1.32	0.0%	-	-	100.0%	0.44	0.58	(0.58)	100.0%	0.44	0.58	(0.58)	100.0%	0.44	0.58	(0.58)	100.0%	0.44	0.58
Sugar	3.00	1.0%	0.00	0.01	1.0%	0.00	0.01	0.00	1.0%	0.00	0.01	0.00	1.0%	0.00	0.01	0.00	1.0%	0.00	0.01
Salt	0.60	2.0%	0.01	0.01	2.0%	0.01	0.01	0.00	2.0%	0.01	0.01	0.00	2.0%	0.01	0.01	0.00	2.0%	0.01	0.01
Fat	6.25	0.3%	0.00	0.01	1.0%	0.00	0.03	(0.02)	1.0%	0.00	0.03	(0.02)	1.0%	0.00	0.03	(0.02)	1.0%	0.00	0.03
SuperMA/2000	185.00	0.0100%	0.00	0.01	0.0100%	0.00	0.01	0.00	0.0100%	0.00	0.01	0.00	0.0100%	0.00	0.01	0.00	0.0100%	0.00	0.01
LipoPan	500.00	0.0000%	-	-	0.0000%	-	-	-	0.0000%	-	-	-	0.0000%	-	-	-	0.0000%	-	-
Admul Datum	29.37	0.0000%	-	-	0.0000%	-	-	-	0.0000%	-	-	-	0.0000%	-	-	-	0.0000%	-	-
Ascorbic acid	54.00	0.0100%	0.00	0.00	0.0100%	0.00	0.00	0.00	0.0100%	0.00	0.00	0.00	0.0100%	0.00	0.00	0.00	0.0100%	0.00	0.00
SSL	12.75	0.2%	0.00	0.01	0.0%	-	-	0.01	0.0%	-	-	0.01	0.0%	-	-	0.01	0.0%	-	0.01
CaPropanate	10.00	0.3%	0.00	0.01	0.0%	-	-	0.01	0.0%	-	-	0.01	0.0%	-	-	0.01	0.0%	-	0.01
Soya	2.20	1.0%	0.00	0.01	0.0%	-	-	0.01	0.0%	-	-	0.01	0.0%	-	-	0.01	0.0%	-	0.01
Yeast	6.20	2.2%	0.01	0.06	2.0%	0.01	0.05	0.01	2.5%	0.01	0.07	(0.01)	2.0%	0.01	0.05	0.01	2.0%	0.01	0.05
Vitamins	13.00	0.2%	0.00	0.01	0.0%	-	-	0.01	0.0%	-	-	0.01	0.0%	-	-	0.01	0.0%	-	0.01
Gluten	13.00	0.0%	-	-	0.0%	-	-	-	0.0%	-	-	-	0.0%	-	-	-	0.0%	-	-
Vinegar	1.00	0.0%	-	-	0.0%	-	-	-	0.0%	-	-	-	0.0%	-	-	-	0.0%	-	-
Total				1.00			0.69	0.31			0.71	0.30			0.71	0.29			0.71

	Unit cost	PLANT BAKERY				3: INCREASE ASCORBIC ACID				4: ALL				Final optimised recipe					
		%	kg	R/loaf	Saving	%	kg	R/loaf	Saving	%	kg	R/loaf	Saving	%	kg	R/loaf	Saving		
Flour	1.86	100%	0.46	0.86	0.0%	-	-	0.86	0.0%	-	-	0.86	0.0%	-	-	0.86	0.0%	-	0.86
Wheat	1.32	0.0%	-	-	100.0%	0.44	0.58	(0.58)	100.0%	0.44	0.58	(0.58)	100.0%	0.44	0.58	(0.58)	100.0%	0.44	0.58
Sugar	3.00	1.0%	0.00	0.01	1.0%	0.00	0.01	0.00	1.0%	0.00	0.01	0.00	1.0%	0.00	0.01	0.00	1.0%	0.00	0.01
Salt	0.60	2.0%	0.01	0.01	2.0%	0.01	0.01	0.00	2.0%	0.01	0.01	0.00	2.0%	0.01	0.01	0.00	2.0%	0.01	0.01
Fat	6.25	0.3%	0.00	0.01	1.0%	0.00	0.03	(0.02)	1.0%	0.00	0.03	(0.02)	1.0%	0.00	0.03	(0.02)	1.0%	0.00	0.03
SuperMA/2000	185.00	0.0100%	0.00	0.01	0.0100%	0.00	0.01	0.00	0.0100%	0.00	0.01	0.00	0.0100%	0.00	0.01	0.00	0.0100%	0.00	0.01
LipoPan	500.00	0.0000%	-	-	0.0000%	-	-	-	0.0000%	-	-	-	0.0000%	-	-	-	0.0000%	-	-
Admul Datum	29.37	0.0000%	-	-	0.0000%	-	-	-	0.0000%	-	-	-	0.0000%	-	-	-	0.0000%	-	-
Ascorbic acid	54.00	0.0100%	0.00	0.00	0.0%	0.00	0.00	(0.00)	0.02%	0.00	0.00	(0.00)	0.0%	0.00	0.00	(0.00)	0.02%	0.00	0.00
SSL	12.75	0.2%	0.00	0.01	0.0%	-	-	0.01	0.0%	-	-	0.01	0.0%	-	-	0.01	0.0%	-	0.01
CaPropanate	10.00	0.3%	0.00	0.01	0.0%	-	-	0.01	0.0%	-	-	0.01	0.0%	-	-	0.01	0.0%	-	0.01
Soya	2.20	1.0%	0.00	0.01	0.0%	-	-	0.01	0.0%	-	-	0.01	0.0%	-	-	0.01	0.0%	-	0.01
Yeast	6.20	2.2%	0.01	0.06	2.0%	0.01	0.05	0.01	2.5%	0.01	0.07	(0.01)	2.0%	0.01	0.05	0.01	2.0%	0.01	0.05
Vitamins	13.00	0.2%	0.00	0.01	0.0%	-	-	0.01	0.0%	-	-	0.01	0.0%	-	-	0.01	0.0%	-	0.01
Gluten	13.00	0.0%	-	-	0.0%	-	-	-	0.0%	-	-	-	0.0%	-	-	-	0.0%	-	-
Vinegar	1.00	0.0%	-	-	0.0%	-	-	-	0.0%	-	-	-	0.0%	-	-	-	0.0%	-	-
Total				1.00			0.69	0.31			0.72	0.28			0.748	0.25			0.748

Table: Plant recipe optimisation

As can be seen in the summary table: Plant recipe optimisation, above, the final industry standard dough gave a 26% recipe cost advantage over the standard flour. In

other words, it was economically worthwhile to pursue the cost of capital to install such a plant. A last note is that on the table above it can be seen that standard plant bakeries have to add vitamins at a cost, while the wet-mill bread has them naturally present. The chart below is a nutritional comparison of most breads on the market indexed against the wet-mill bread. The healthiest at the time was the fortified Sasko Sam brown bread indicated by a red stripe. It can be see that, without fortification, the wet-mill bread far surpasses anything else on the market nutritionally.



Graph: Chart showing all brands indexed to wet-mill bread.

5.3. EFFECT OF COARSENESS OF GRAIN ON DOUGH STRENGTH

This information was needed to minimise the cutting time. The longer the dough mixture was cut, the finer the dough became, but the hotter it became as well. A range of doughs was produced using differing cut times. The resultant dough strengths were tested using the abuse test. The two finest cuts were by far the strongest, and the very coarse one collapsed and did not recover in the oven. Thus the shortest cut time that we could get away with in the 20l bowl cutter, was 7 minutes – corresponding to a particular known dough texture described below.

	Most Coarse	More Coarse	Coarse	Fine
Abuse Test Result	collapsed	5mm drop	none	none

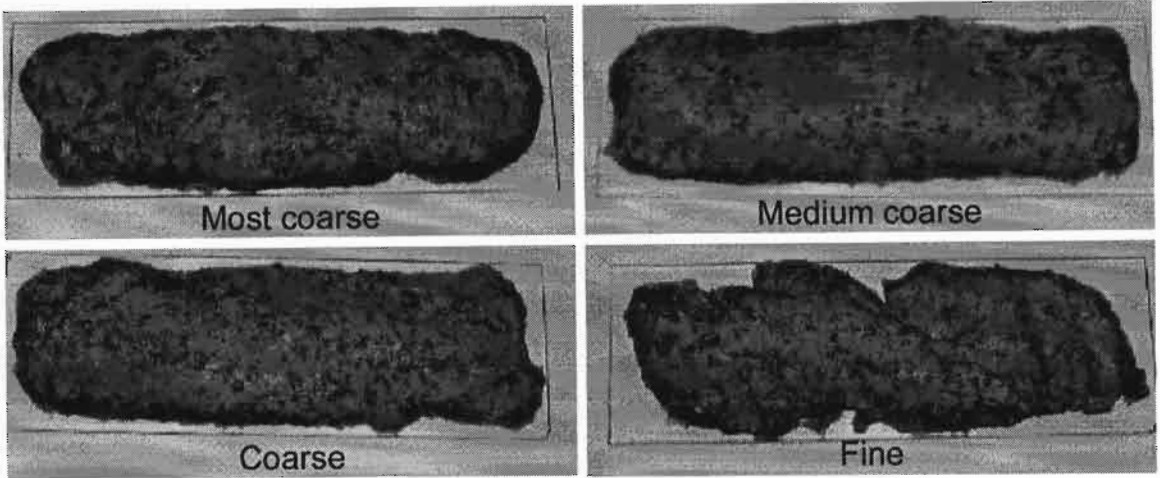
Table: Coarse grain abuse tests

This result is logically explained, in that if the cut is too short and therefore does not release the endosperm from its coating of fibrous bran, then insufficient gluten will be present to form a stable matrix.

5.3.1. Coarseness Standard

It was difficult to define a standard for coarseness of grain. It was decided to follow a visual method similar to that used in a colour chart¹. The four descriptions of most coarse, medium coarse, coarse and fine were decided upon by taking samples every 30 seconds after dough had formed and then selecting samples that showed an easily observable difference. 10 samples of each of these cut sizes were then frozen to act as reference samples. A picture of a sample for each of the four stages can be seen below:

¹ A colour chart is a common quality assurance tool that is used in most fast moving consumer goods to ascertain quality versus a standard visual chart.



Picture: Coarseness standard

5.4. MAXIMISE PERCENTAGE OF WATER

The greater the percentage of water in the dough, the softer and moister the end product. Due to the greater percentage of bran (fibre) in the wet-mill dough, there is an increased capacity to absorb water. The baking industry's standard water content is 60%. In order to find the maximum percentage that wet-mill dough could 'hold', a range of doughs were produced with differing water contents.

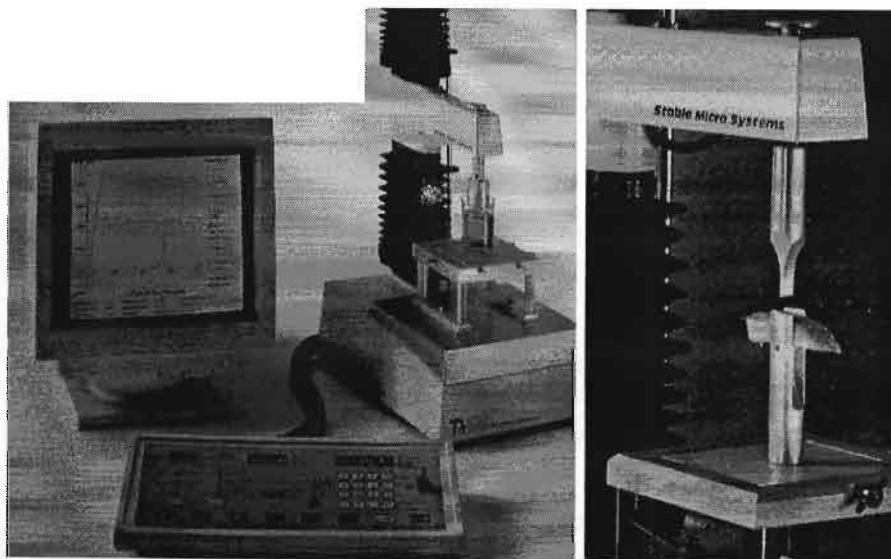
	Trial of differing water contents				
Water (%)	70%	69%	65%	64%	62%
Comments	v. sticky	sticky	fine	fine	fine
Abuse Test Result	8 mm drop	5mm drop	none	none	none

Table: Trial of differing water contents

The loaf with 70% was too sticky to roll properly and thus did not prove very well- it also dropped by 8mm, which was not recovered in the bake. The 69% water content, although still difficult to work with produced a superb loaf. It did drop by 5mm in the second abuse test, but it fully recovered during the bake to form a very moist, soft loaf. For workability reasons the optimum dough was 65% water: It was easy to divide and round, and formed a very strong dough that passed the abuse test easily.

5.5. OPTIMISE SOAK TIMES THROUGH CRUSH TEST

A controlled series of 'crush' tests was performed to determine the optimal soak time and temperature. Three temperatures were used: ambient, 35 ° and 40 ° (temperatures C, B, A). It was thought that by slightly elevating the soak temperature, the length of the soak time could be reduced. The machine used was the TA-XT2 Texture Analyser¹, which can be seen in the pictures below. Five randomly chosen grains were placed in the cradle and the machine recorded the force required to shear all grains. The absolute force was not of interest, but it was hoped that a pattern might be revealed that would indicate at what length of soak and what temperature the grains were 'softest'.

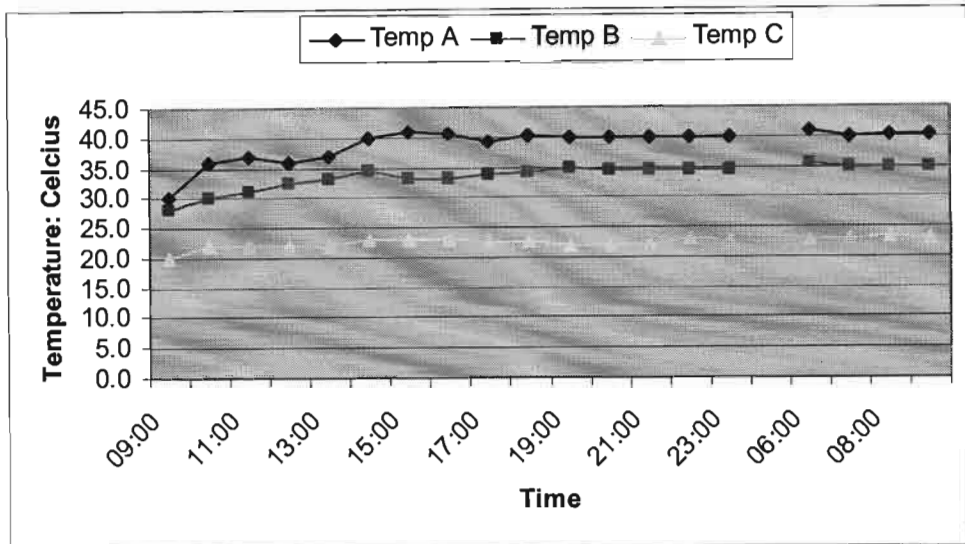


Picture: TA.XT2 Texture Analyser

The temperatures were controlled by using three different incubator ovens² (Ovens, A, B, C). Their recorded temperatures are graphed below.

¹ TA.XT2: Texture analyser, version 5.16, October 1995. Manufactured by Stable Micro Systems, Surrey England. Calibrated with a 50Kg load cell, with an accuracy of $\pm 1g$.

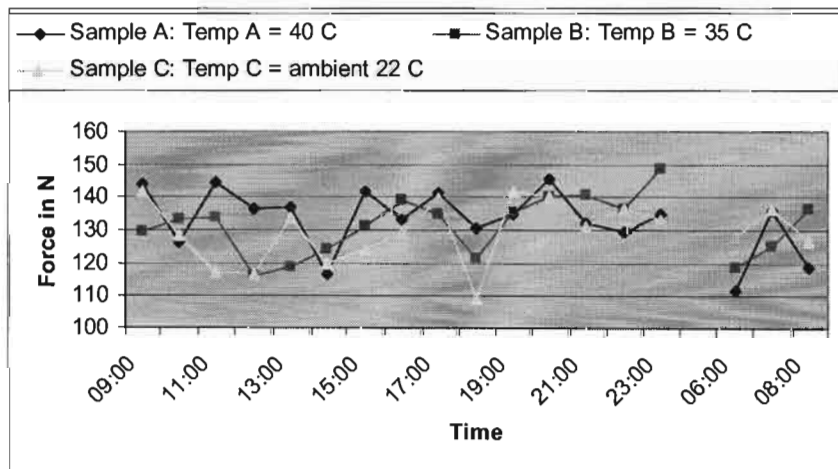
² Oven A: Labotech, South Africa, with an accuracy of ± 1 C. Oven B: Memmert, Johannesburg, South Africa with an accuracy of ± 1 C. Oven C: Labcon, South Africa with an accuracy of ± 0.1 C.



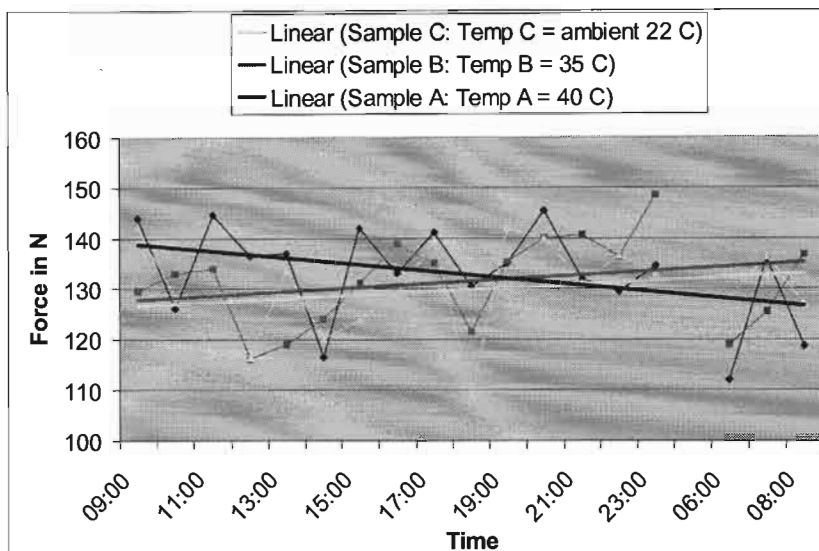
Graph: Temperature tracking of crush test

The graphed results of the crush test revealed no helpful trend. What was interesting to note was that the elevated temperature did not improve the soak time.

The results are shown in the graph below. To try and extract some useful information, linear trend lines were superimposed and these graphs are included below the others. From both graphs, it was clear that an alternative way of optimising the soak time was required.



Graph: Figure Crush force



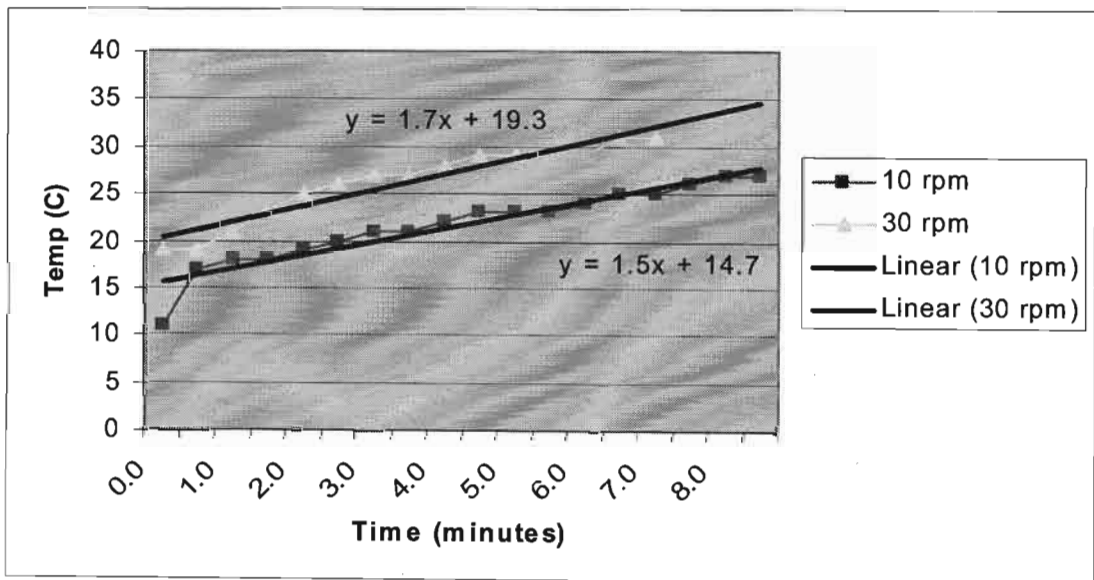
Graph: Figure Crush force with linear trend lines

The optimised time for soaking was finally established through an empirical series of 'bowl cuts' where the coarseness of the grain after a 6 minute cut was evaluated and compared to wheat of differing soak times.

It was clear after this that a soak time between 9 -14 hours was best. There was no perceivable improvement after 14 hours.

5.6. TRANSLATIONAL BOWL SPEED EFFECT ON HEAT LOAD

It was thought that the bowl speed (the translational speed of the bowl rotating the mixture through the blades) influenced the rate of temperature increase. However, when tested, as can be seen in the graph below, the rate of increase was influenced by only a very marginal amount: the rate increased from 1.5°C/min to 1.7°C/min, which means over the expected mixing time of 8 minutes, the extra temperature gain would only be 1.4°C. This was good news for the design of the scaled plant bakery vertical wet-mill machine, as it meant that the Diosna mixing bowl could be used without a material increase in thermal load (see Chapter 11)



Graph: Temperature gain during mixing

5.7. IMPACT OF GRADE OF WHEAT ON BREAD

Three grades of wheat were tested: Canadian Red (the standard for BPS), Freestate BP1 and utility Argentinean wheat. A large batch of each type was baked using the optimised plant bakery recipe with 65% water. The trial was repeated due to the poor results from the Argentinean wheat. The Freestate wheat and Canadian wheat passed all abuse tests, but the utility Argentinean wheat passed only 50% of the time. It was interesting to note that if a smaller loaf had been acceptable, then the Argentinean utility wheat would have passed with tremendous costs savings. The percentage of loaves that passed the abuse test are summarised below:

	Argentinean	Canadian	Freestate
Trial 1	40%	100%	90%
Trial 2	60%	100%	100%

Table: Types of wheat passing abuse test

5.8. STORAGE OF WHEAT AND DOUGH

5.8.1. Storage of Wheat

During the laboratory experiments we had access to wheat straight off the farm as well as graded wheat from a miller sponsor. The millers refer to wheat depending on whether it has been through the conditioning process or not. "Conditioned" wheat has been through a humidification process, the immediate stage pre-milling (used to slightly soften & toughen the brittle outer layer of the kernel). Obviously for our trials we required unconditioned wheat.

The wet soaked unconditioned wheat can be stored up to 12 hours at ambient temperatures (not exceeding 22°C) and up to 3 days when chilled to below 10°C (a commonly used chilling temperature). This information was found by putting sufficient wheat on to soak so that samples could be taken every 12 hours (7am and 7 pm), cut, and baked off. Long before the wheat starts to become rancid, it begins to sprout. When the wheat sprouts it is easy to see little shoots growing out of the end of the kernel. Also when it sprouts an excess of alpha amylase is produced which breaks down the starch, producing too much sugar and maltodextrins. All this affects the strength of the gluten structure and the dough can collapse during proving or baking.

The longer than expected stability of both the dough and the soaked wheat is attributable to the presence of salt. The salt has an inhibitory effect based purely on osmosis (which is understandable as at levels of 5% to 10% it is used as a curing preservative).

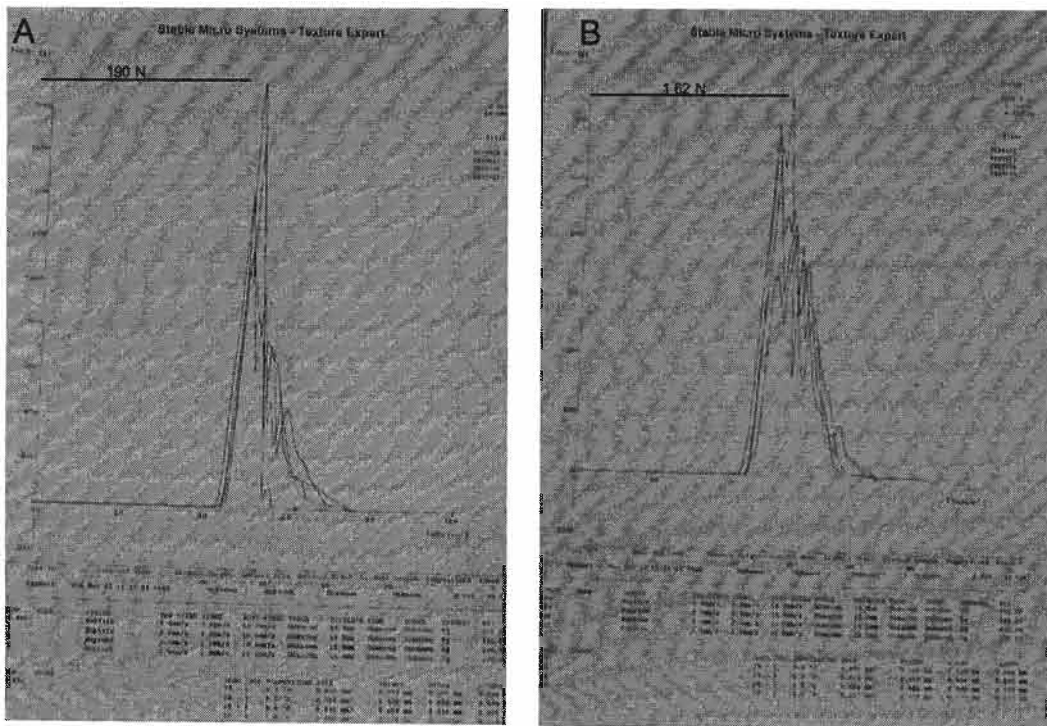
5.8.2. Storage of Dough

Due to the preservative action of the salt in the soak water, un-chilled dough can last up to 4 hours (depending of course on the ambient temperature). Chilled, the dough can last for much longer, up to 48 hours. The dough referred to is really the early stage dough that, in the smaller batches, was transported from the 20L bowl cutter to the dough mixer- i.e.: before addition of ingredients. The dough will obviously not last that long if the ingredients are added.

5.9. EXPERIMENTAL DETERMINATION OF BLADE LOADING

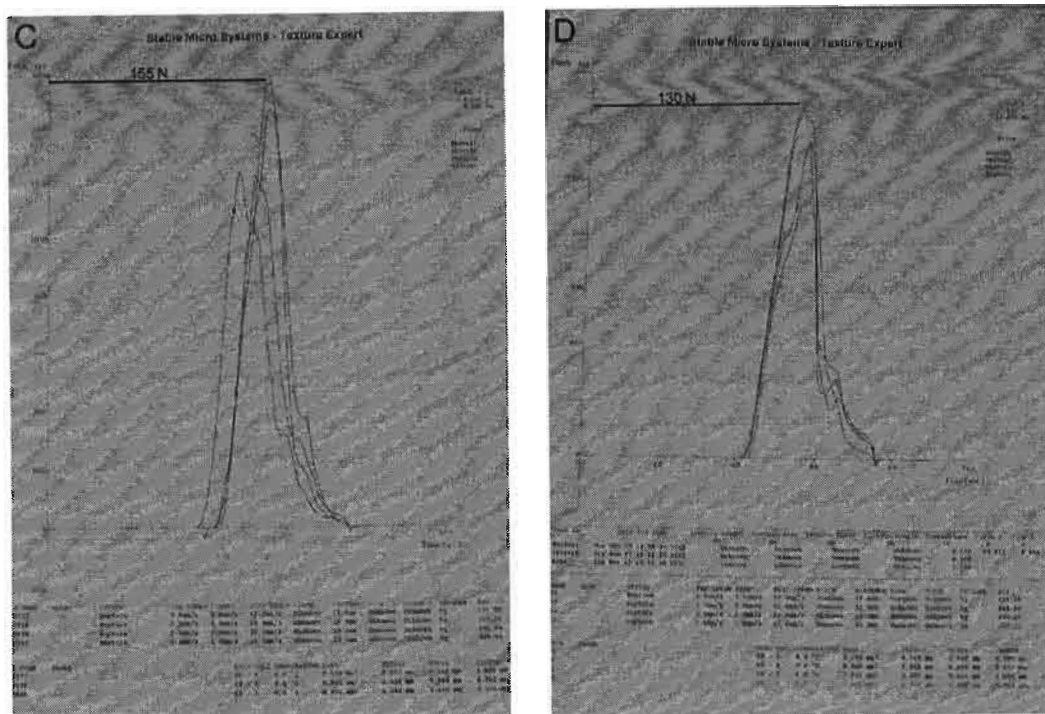
While the TA-XT2 Texture Analyser was set up to do the optimised soak tests, a series of tests was undertaken to examine the peak load of the machine slicing a grain of wheat. This load could be used to determine the type and magnitude of the loading on the blade slicing through a single grain. This could be translated into a uniform load all the way along the blade. Therefore, it was important to understand the way in which the loading changed as the wheat changed from dry to wet. Wheat was soaked at ambient conditions, and samples taken at 2.5hrs, 3.5hrs and 13hrs.

5.9.1. Peak loading



Graph: Peak loading A & B

The first experiment was a series of tests performed on wheat sampled at differing soak times. A crush test was performed on a single grain and then repeated four times. The four results were summarised on a single graph. Graph A, above, shows the curves of dry wheat, where the peak loading can be seen to reach 200N (20000g). The curves of both sample times A and B are 'spiky', indicating the brittle nature of the wheat. Graphs C and D below clearly show that the maximum force decreases as the soak time increases, with a minimum force at 13 hours (graph D). These last two sets of graphs are also 'smoother', showing that the grain is softer.



Graph: Peak loading C and D

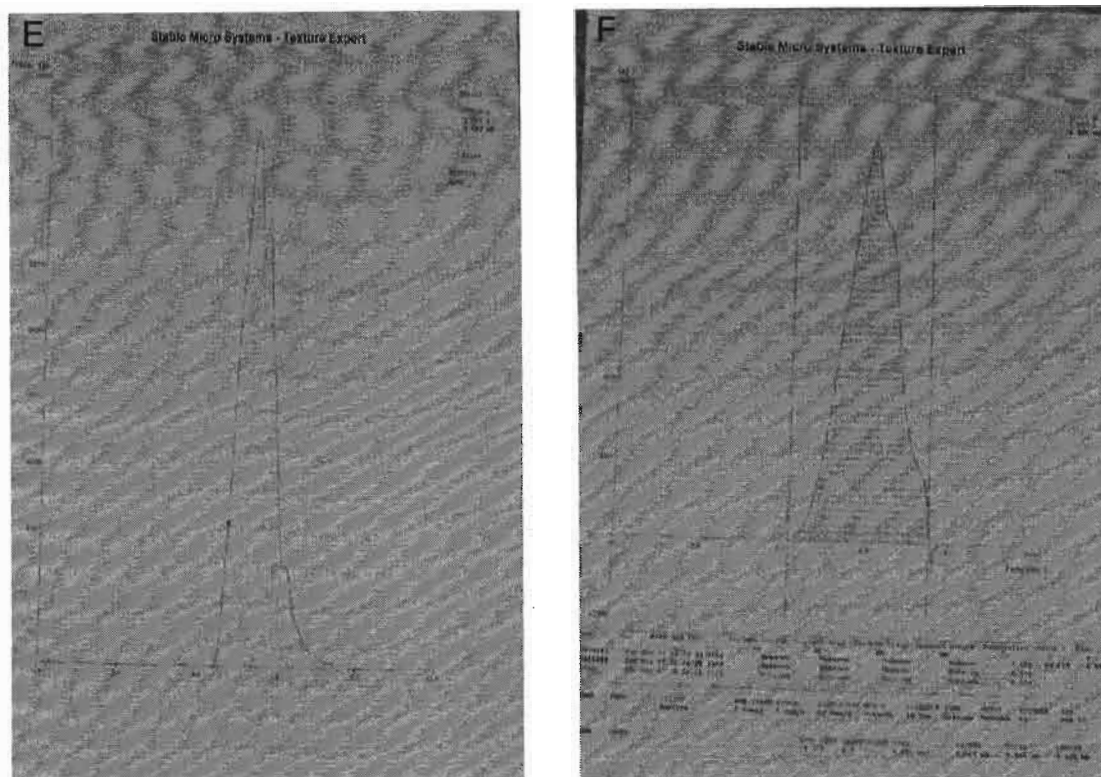
The table below summarises the observations from the above peak loading experiment:

	Series A	Series B	Series C	Series D
Soak Time (hrs)	0	2.5	3.5	13
Peak Load 1 (N)	190	162	155	130
Peak Load 2 (N)	165	144	145	115
Peak Load 3 (N)	140	132	122	110
Peak Load 4 (N)	115	125	120	100
Average Load (N)	152.5	140.8	135.5	113.8

Table: Summary of the peak load tests

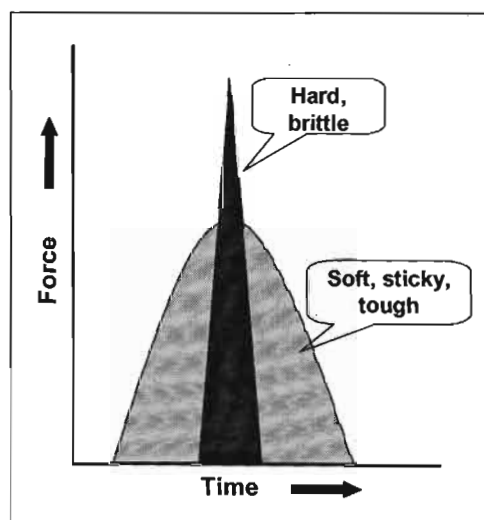
5.9.2. Energy Absorbed

The energy utilised is indicated by the area under the curve. The single curves below show the type of loading for a dry grain (graph E) and a wet grain (graph F). As the grain softens, not only is the peak load affected but also the time taken to pass through the grain. Graph E shows a peak load of 160N and load duration of 1.5 seconds; the wet grain lasts at a force of 105 for 2.5 seconds.



Graph: Peak loading E and F

The difference in the loading can be exaggerated as follows:



Sketch: Force required to slice dry vs. wet grain

6. VERTICAL WET-MILL CUTTER IDEA GENERATION

Many attempts were made to try to develop the dough inside the bowl cutter; however it became quite clear that a normal dough mixer was far superior at developing dough more quickly than the blades of the bowl cutter. It was therefore initially thought necessary that the wheat would have to be sliced in a bowl cutter and then somehow transported to a dough mixer. It was from this assumption that the first scaled plant-sized machine ideas evolved.

This chapter describes the iterative design process of the idea generating phase. As Ullman¹ states in his *Introduction To The Mechanical Design Process*: “you only learn design if you do design” and secondly you need “the knowledge to generate ideas as well as the knowledge to evaluate them.” The idea generation phase is the first step in designing a solution to an already well-defined problem. Chapters 7 through 10 place the wet-mill cutter in context, as well as complete the process design and plant bakery operational interface. Chapter 11 picks up the machine design process thread and applies it to the best evaluated idea from this phase.

6.1. IDEA 1: USE ‘OFF-THE-SHELF’ LARGE BOWL CUTTER

This design initially seemed very logical. The machine design had already been optimised and heat load problems solved by jacketing² the bowl. The large bowl cutter had however four serious disadvantages:

- The first disadvantage was the difficulty of offloading the undeveloped dough. The dough is sticky and does not come out easily. The offloading mechanism is crude and there is substantial opportunity for product wastage.

¹ David G Ullman, *The mechanical design Process*, 1992, pg xii

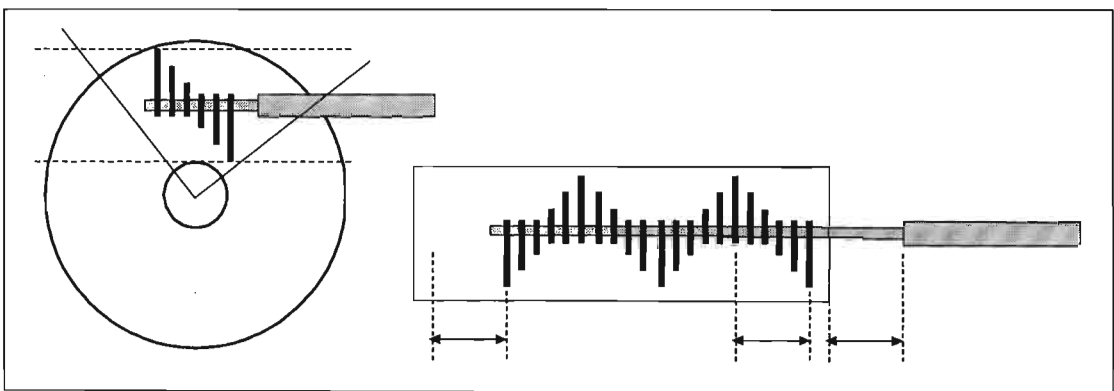
² Jacketing is the preferred method of controlling temperature (whether hot or cold) in the food industry. It is a non intrusive method where the food container (e.g.: tank, bowl or pipe) is shrouded. A coolant is introduced into the gap between the container and jacket which cools the container and thus the food product. In the meat industry (where the bowl cutter is predominately used) the jacket is usually filled with chilled water, but in industries requiring greater reduction in temperatures (e.g.: the margarine industry), the coolant often used is ammonia.

- Secondly, the bowl cutter develops a thick layer of product build-up in the lid section covering the blades. This accumulation runs at approximately 5% – 10 % of the cut volume, which is an unacceptable level of production loss. To require operational instructions to clean the lid mid-process would be cumbersome and probably encourage safety violations.
- The third issue is linked to the first in that requirement of cleaning every batch is unacceptable. In a normal bakery environment the mixing bowls are cleaned at the end of each shift, not at each batch. Also, there would be no waste facility in most bakeries to wash the food remains into.
- The last reason is that a 250kg bowl cutter is exorbitantly expensive at R550,000¹. Thus, in order to keep up with the plant bakery rate of 5000 loaves per hour, 2 of these machines would be needed- that is over R1 million before any installation has occurred.

¹ Verbal quote from BT Enterprise, South Africa, January 2002.

6.2. IDEA 2: RECIPROCATING HORIZONTAL DRUM

The replacement of the rotating torpid (half doughnut shape) with a cylinder seemed a logical step forward, in that the volume is much more efficiently used. Instead of rotating through an un-worked 270°, the dough will be worked the entire length of the drum. The reciprocal action would be just sufficient to move the outer ends of the dough through a complete knife set¹. A comparison of 'action zones' in the sketch below reveals that the horizontal drum would be at least 4 times more efficient.



Sketch: Rotating vs. reciprocating efficiency

Concerns regarding this idea were:

The reciprocation action is very high-wearing on parts, so maintenance costs of the machine would have been high.

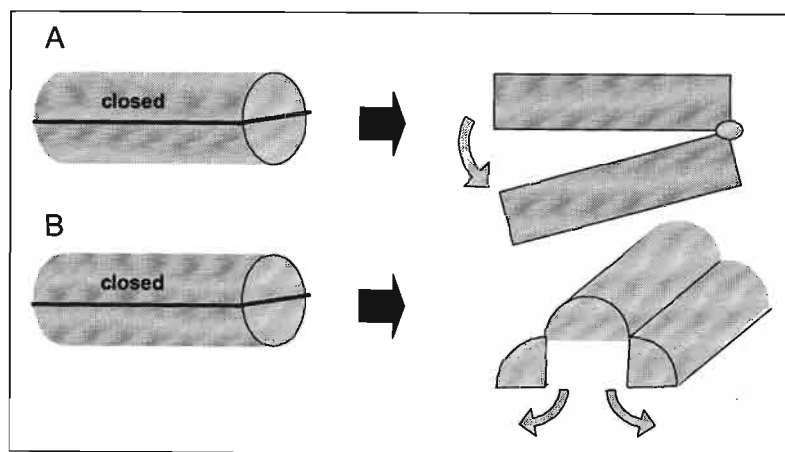
The offloading of the dough from the machine would have been very difficult and would have required an ingenious insert to clean the dough off the blades.

Although the action zone space is more efficient, there would have to be enough space for the entire lid to retract in order to empty the drum.

¹ A knife set is the set of 6 blades indexed at 60° described in detail in Chapter 7.

6.3. IDEA 3: ROTATING DRUM WITH OFFLOADING

A few modifications were suggested for the horizontal drum. The first was to eliminate the reciprocating action of the drum. If the drum itself rotated, there would be sufficient mixing of the dough across the 6mm blade gap to void the need for a reciprocating action. The second dealt with the problem of off-loading the machine. There was an initial idea to hinge the lower half of the drum and use it as a chute along which the dough could travel. After calculating the mass of this lid as about 300kgs, it was realised that such a hinge was unrealistic and would be a nightmare to operate (see sketch A). Another option seemed better: to hinge the bottom section as 'bomb doors' where each side opened along the length of the drum, thus spreading the hinge load (see sketch B).



Sketch: Offloading comparison.

It was also suggested that the direction of the shaft be reversible to help extract the sticky dough. The machine had improved; however there was still the problem of exposed transport of the dough. It is not hygienic to transport food products exposed to open air, but to enclose the machine and conveyor would then make this machine more expensive than the large bowl cutter.

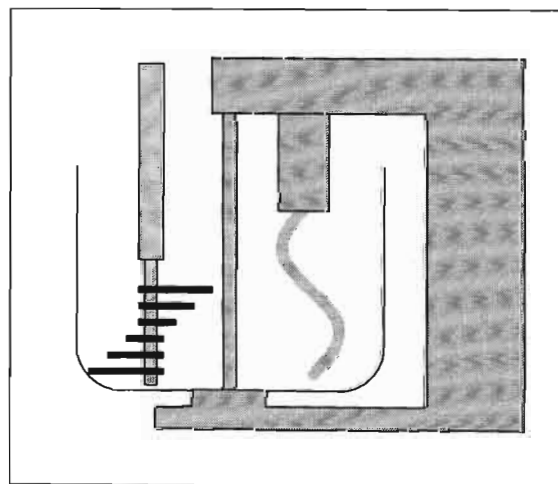
6.4. IDEA 4: ROTATING DRUM ABOVE DOUGH MIXER

This design solved most of the problems with the horizontal drum. If the drum were situated directly above the dough mixer with bay doors opening into the bowl, then the hygiene problem was solved. However the machine was still too expensive, due to increased installation cost as the platform it would stand on would need to be very strong to withstand the heavy rotational vibrations.

6.5. IDEA 5: VERTICAL WET-MILL CUTTER

This design was an intuitive leap forward and it stemmed from the need to have the dough in the same bowl as the mixer. On visiting a number of plant bakeries and observing their dough mixers, it was noticed that they were very similar to the 50kg mixer in the lab: the mixer blade was offset on one side of the bowl and not in the centre, leaving a huge space on the other side of the bowl—enough space to house another set of blades! At a conceptual level the machine could readily be visualised by rotating the bowl cutter (minus the bowl) vertically through 90 degrees, and inserting the shaft into the mixer.

This idea could be verified immediately, as it was possible to modify the existing bowl cutter and combine it with an existing dough mixer. A sketch of the proposed arrangement can be seen below.



Sketch: Proposed arrangement of vertical cutter and dough mixer

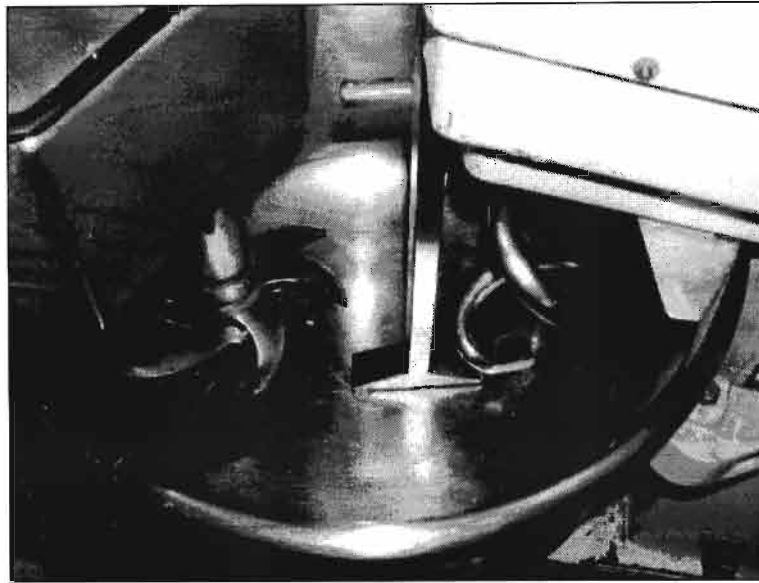
In order for the bowl cutter to safely operate in the vertical, it had to be securely mounted. This was achieved by Rawl-bolting the bowl cutter frame to the wall. Even

though the 12mm Rawl bolts were secure, the bowl cutter was also supported from below as it had been placed on ash blocks with a thick 1 inch rubber mat to act as a damper. The arrangement of both the inverted bowl cutter and the dough mixer can be seen in the picture below, together with the large black plastic bins that were used to move the wheat and dough around the lab. (As an indication of scale, the black bin is about 1m in diameter.)



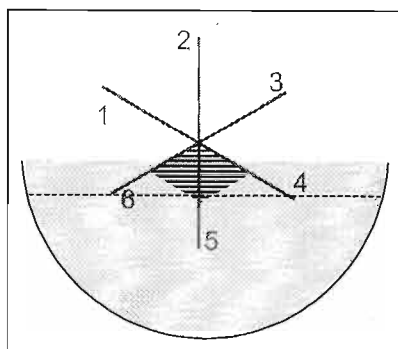
Picture: Mounting arrangement of wet-mill cutter on the wall

Placing the shaft in the bowl was a great step forward as the dough could be cut and developed in one bowl, with no need for transport. A second major benefit was that the last stage of the recipe optimisation could occur in the new 50 kg rig (as described in Chapter 5). Starting this new machine for the first time was quite nerve-wracking. All observers were placed behind heavy guarding and the machine was started remotely. Other checks included inspecting the circuit breakers, which had to be increased to allow for increased loading.



Picture: Prototype vertical wet-mill machine

What was very surprising was the efficiency of the vertical wet-mill cutter. More than double the mass of dough could be processed in exactly the same amount of time, with exactly the same blade arrangement. After an examination of the action zone of the new machine (explained in more detail in the next chapter) compared to the original horizontal bowl cutter (see sketch below), a distinct difference could be seen. The action zone of the bowl cutter is just over 120° if the bowl is exactly half filled. However, in operation this cannot happen and the bowl cutter is usually filled to the dotted line indicated on the picture. At this height, the action zone is less than 120° , and thus the effective zone of the new machine (at 240°) is more than double that of the bowl cutter.



Sketch: Bowl cutter action zone

The next phase was to establish a number of parameters of the new machine: these trials are explained in detail in the next chapter.

7. WET-MILL CUTTER BLADE DESIGN VARIABLES

The test rig worked, yet the knowledge of how and why had still to be determined. The crux of the design was the vertical blade set, and this became the focus of the next series of experiments. It was important to understand and optimise specific blade arrangement properties so that the effectiveness of the stack itself could be investigated. The outputs of these experiments were important as they formed the constraints or inputs that could be used to scale the rig to a plant bakery machine.

7.1. BLADE PARAMETERS

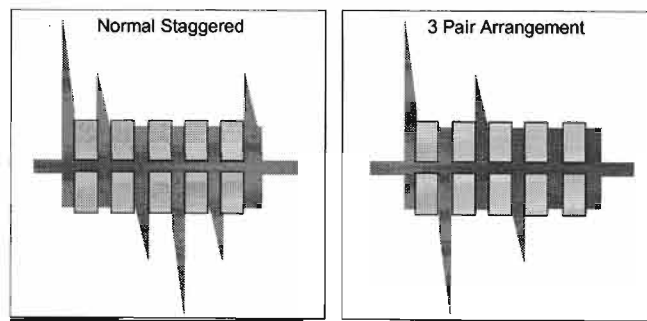
There were a number of unknowns with respect to the blades. The first unknown regarded the spacing of the blades. Initially, this was fixed because the 20L bowl cutter was supplied with 6mm Teflon 'washers'. As the manufacturer could not explain the reason for this particular size, it was decided to investigate whether a finer cut could be achieved by placing the blades closer together. A second investigation was the pattern of the blades: should they be indexed around the circumference or should they be arranged in sets of pairs? The third variable was to understand the relationship between the number of blades and the fineness of the cut.

7.1.1. Blade Spacing

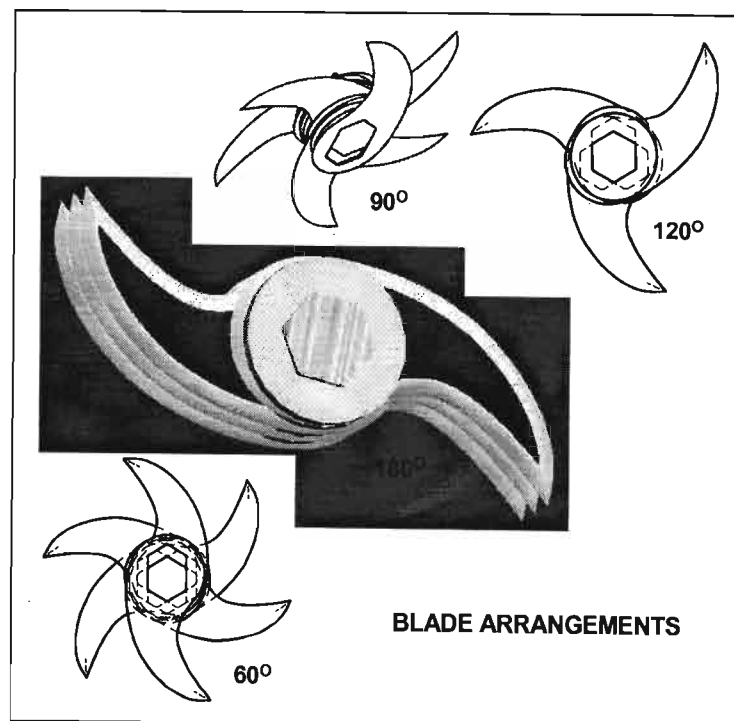
Four new sets of Teflon washers were produced, each with a different thickness: 2mm, 3mm, 4mm and 5mm. (It turned out to be too difficult to produce spacers of 1mm as the Teflon either warped or broke.) A series of cuts was completed with each set of blades. Each batch was cut for a fixed 6 minutes. The coarseness of the end products was then compared. The 6mm cut was the best. The entire series was repeated with the same result. After some brainstorming the following hypothesis can be presented: the blades are sharpened on one side only. They thus act like a propeller pulling the dough mass through the blade set. The phrase 'action zone' was coined to describe the section of dough that is being cut. Once the blade leaves this action zone it leaves a wake behind it, so if the next blade is set too close it will cut within this wake and have no effect on the dough.

7.1.2. Blade Set Arrangement

For this test the knives were arranged in multiple balanced formations – 60° up to 180° offsets. The cut achieved from each of these was compared to the standard 60° indexed knife cut. The two knife arrangements have been sketched below with examples of the other arrangements in a 3-D technical drawing format below that. It was again found that the standard indexed arrangement worked better. A hypothesis is that the time taken to turn through 180° is long enough for the dough to leave the action zone. Thus an increase in spacing or index angle results in an inefficient cut. The quickest cut was with a 6mm spacing and blades indexed at 60° where a fine dough results from a single section of dough seeing 'action' a number of times in each pass of the blade. If this section of dough only sees a single blade then it will take proportionally more time to get the same cut.



Sketch: Paired 60° knife arrangements



Drawing: Blade optimisation arrangements

7.1.3. Blade Relation to Fineness of Cut

This series of tests was undertaken to verify a linear relationship between the number of knives and the fineness of the cut. This test was meaningful only in the horizontal bowl cutter as it lengthened the residence time of the dough in the 'action zone'. However in the vertical dough cutter, an increased height of knives was meaningless if the bowl was not full enough to reach them. A relationship was, however, discovered between knife stack height and the effective processed volume, which is described in the next section.

As was expected (and is summarised below), 2 blades were ineffectual, and 3 blades took over 14 minutes to produce a similar standard quality dough.

	Trial A	Trial B	Trial C	Trial D
No. of blades	2	3	4	6
Time to cut (min)	-	14	10	7

Table: Cut time vs. no. of blades

7.2. BLADE STACK HEIGHT

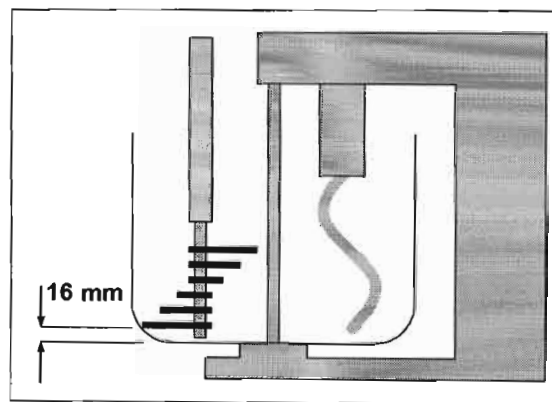
When the drive mechanism and shaft were stripped off the bowl cutter and inverted into a 50 kg dough mixer, trials were run to establish the maximum quantity of dough that could be cut. In order to further scale the design, the relationship between the blade stack height and volume of dough that could be successfully processed had to be established.

A number of other variables, such as height of the blade stack's lowest knife from the bottom of the bowl, and the direction of rotation of the bowl, also had to be determined.

7.2.1. Height of blade stack from bottom of the bowl

This trial was very tedious and time consuming, as the entire machine had to be lifted and lowered. The bowl cutter had been attached to the wall using four 12mm Rawl bolts. Thus it was the dough mixer that had to be elevated. For this purpose wooden spacers were cut upon which the dough mixer could be clamped. These performed two purposes: firstly they dampened the vibration of the machine and secondly they raised it. The initial construction had the bottom of the shaft 10mm above the mixing

bowl (measured parallel to the shaft using a vernier), with the first blade 20mm above the bowl. In the first trial, a layer of wheat below the first blade was left uncut. The bowl was then raised by adding more spacers until a cut was achieved where the bottom of the bowl was visible through the centre of the vortex. Raising the bowl above this height would have 'eaten' into the effective 'action zone' and thus made the machine less efficient. This height was determined as 16mm from the bottom of the bowl to the first knife and is sketched below. As shown in the sketch, the limiting factor became the curvature of the bowl, as the blades were set so that they cut as close as possible to the vertical side of the bowl.



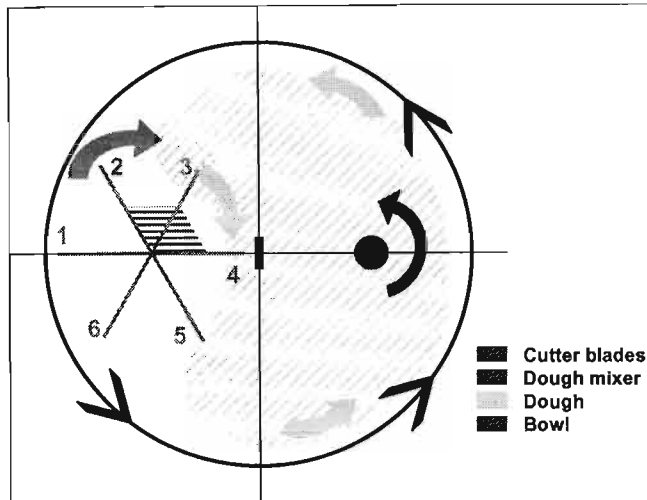
Sketch: Blade height above bowl

7.2.2. Direction of Rotation

The relocation of the blade-set as close as possible to the bottom of the bowl eliminated the problem of uncut wheat (remaining stationary beneath the blade set). Even though this had been solved, we still could not determine the reason for the poor quality of the cut which was not nearly as good as that achieved in the horizontal bowl cutter. The cut took over 11 minutes and did not produce a fine textured quality dough.

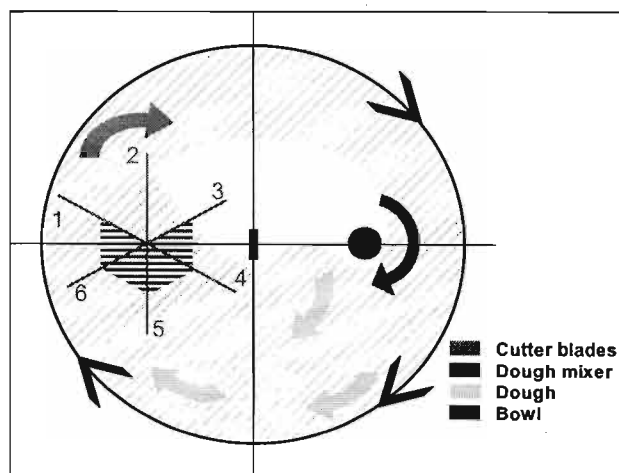
Both the bowl cutter and dough mixer were driven using a three phase power supply. The way in which the motor is wired determines in which direction it rotates. It had been important to get the correct direction of rotation for the bowl cutter, as the blades were clamped in position using a threaded nut, which could have unscrewed- a possibly fatal disaster! Not as much attention was paid to the direction of the bowl. Closer observation of the mass flow within the bowl revealed the pattern below. It was clear that the bowl was imparting centripetal acceleration to the dough and throwing it away from the blades. The effective action zone was between blade position 2 and 4

(see sketch below), an angle of only 120° . Thus not much dough was passing through the action zone: the majority of the dough was skirting around the blades, resulting in an 'empty' region within the blade-set inside the bowl.



Sketch: Incorrect rotation of bowl.

Once the bowl and mixer direction had been reversed, the cut dramatically improved. Not only was fine-textured dough achieved, but it was possible in the much reduced time of 8 minutes. As can be seen below, the dough is forced into the action zone.



Sketch: Correctly rotating bowl

The effective action zone is between blade positions 3 and 1, an angle of 240° . In other words per unit of time this arrangement is roughly a factor of 2 more efficient.

7.2.3. Blade Stack Height and Volume.

This series of experiments had to be undertaken in order to get some indication of the scalability of the 50kg machine to a 250kg machine.

The first set of experiments was to see how much dough could be processed in the new vertical 50kg arrangement.

In the original bowl-cutter set-up, at a wetted wheat density of 715 kg/m^3 , we could theoretically only accommodate 17.8kg. However, we took advantage of the design ullage and extended the capacity to 20kgs, as a bonded mass quickly formed due to the elasticity of gluten. Thus the maximum quantity that the blade-set had seen in the 25l bowl-cutter was 20kgs.

With the new vertical set-up the trial was started with 20kg and each sequential batch was increased by 5kgs. The behaviour of the dough in the new combined machine was watched closely. It was important that the top blade could be seen, otherwise there would be dough that was not being drawn into the action zone. 25kgs through 45kgs worked well; it was only at 50kgs that the dough started to pull over the blade set.

Given this maximum processed volume, it was important to understand how this relationship worked. If all other variables were kept constant how did volume relate to blade stack height? The cutter was set up 4 times, each time with a different number of blades. The results when using volume as an indicator did not reveal a relationship, but if the volume was translated into a height, the ratio of height of dough to blade stack height seemed to stay constant (as seen in the table below) at the value 2. Thus for the large machine, the end volume is known, the diameter of the bowl is known, and so the height of the blade stack can be determined.

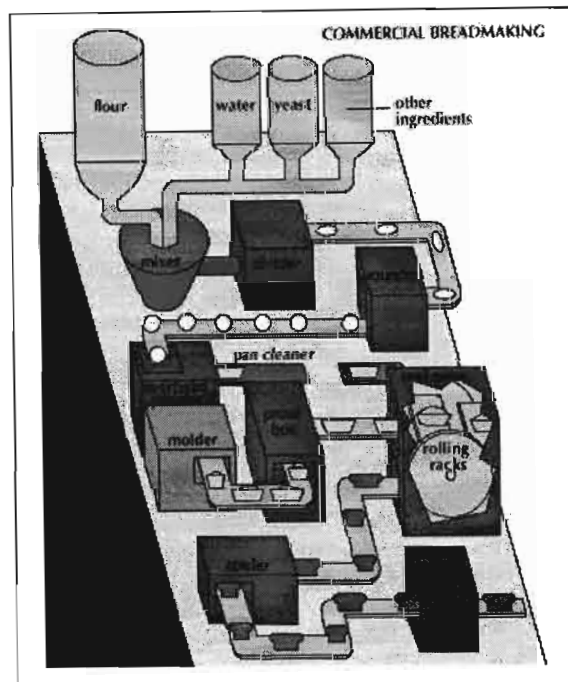
	Trial A	Trial B	Trial C	Trial D
No. of blades	2	3	4	6
Blade Height	25 mm	33mm	41mm	49mm
Height of dough	≈55mm	≈60mm	≈80mm	≈100mm
Ratio	2.2	1.8	2.0	2.0

Table: Relationship between blade stack height and dough

8. WET-MILL INTEGRATION INTO A PLANT BAKERY

In order to successfully integrate into a plant bakery environment, the new equipment had to be correctly scaled to match existing process flows. This involved modelling an existing plant bakery. A second model had to be constructed to determine and then optimise wet-mill processing times versus process equipment size. A final analysis revealed the extra manning requirement of the wet-mill plant.

8.1. PLANT BAKERY PROCESS FLOW



Schematic: Plant bakery process flow

The above schematic will be used as reference for the various processes within a plant bakery. There are 10 steps which either occupy time, or labour, or both: loading ingredients, mixing, dividing, rounding, pre-proofing, moulding, proofing, baking, cooling, and slice/wrapping. These steps have been modelled to find total time (lead and lag) per batch as well as labour requirement of production. At no stage are the bakery overheads examined, as the wet-mill production will be introduced into an existing facility and the costs/savings (of the marginal volume only) will be used to ascertain project viability (see Chapter 12 for more detail).

After an initial exploration of the plant bakery system, it was clear that mixing was the engine room of the bakery. It was also the bottleneck. The table below summarises

the details obtained about mixing, namely number of loaves per day, from which the actual average rate per hour could be calculated. This average rate was needed to complete the process flow model for the rest of the plant.

Variables	Values	Comment
Flour per 700g loaf (g)	460	1
Dough per 700g loaf (g)	773	2
Rated loaves per hour	5000	
Kg dough per hour	3867	
Batch size (kg)	300	3
Batch rate (per hour)	4.8	4
No. of mixers for rated loading	2.69	
Actual number of mixers	2	1
Hrs cleaning per mixer / day	1	1
Number of batches per day	220	5
Max loaves per day	85337	
Actual average loaves per hour	3556	

- 1 From Pioneer Plant bakeries
- 2 60% water and 8.13% ingredients of dry weight flour
- 3 Standard Diosna mixer
- 4 10 minutes mixing, 2 minutes to load, 30 sec to swap bowls
- 5 Take into account cleaning

Model: Plant bakery mixing (note: white cells indicate inputs)

It was quite obvious that all the plants visited were running far under capacity, meaning two things:

- We could expect further consolidation in the mass-market baking industry. (In the 2.5 years of the project, two of the Pioneer plant bakeries visited closed down.)
- It was an ideal opportunity to ask questions and ‘waste’ the time of busy industrial technicians!

The total plant bakery process flow (of the 10 steps described above) is tabled below:

	Notes	Loading 1	Mixing 2	Dividing 3	Rounding 4	Pre-proof 5	Moulding 6	Proofing 6	Baking 5	Cooling 5	Slice/wrap 7
Timing											
Time per loaf (min)		2	10	0.015	0.01	15	0.015	60	30	30	0.16
Batch (b) or continuous (c)		b	b	c	c	c	c	c	c	c	c
Total time per day (hours)		7.3	36.7	21.3	14.2	23.0	21.3	23.0	23.0	23.0	88.3
Manning											
Manning per shift		0	1	1	0	0	0	0	1	0	2
Manning 3 shift		0	3	3	0	0	0	0	3	0	6
Cumulative Manning		0	3	6	6	6	6	6	9	9	15

Model: Plant bakery process flow

There are a number of calculation notes that are itemised above and explained below¹.

Notes	
1	2 min per batch, 220 batches
2	10 min per batch, 220 batches
3	Actuated 0.9 seconds per loaf (rated speed 0.7 to handle 5000 loaves per hour)
4	Actuated 0.6 seconds per rounded dough
5	Continuously 'on', whether dough/loaves present or not. 1 hour cleaning per day
6	Actuated 0.9 seconds per loaf (rated speed 0.7 to handle 5000)
7	30% of loaves sliced, on 2 slicers, 10 seconds per slice

Notes: Plant bakery process flow

8.2. INTEGRATED WET-MILL PROCESS FLOW

8.2.1. Wheat and Flour Flow Rates

The modelling of the plant bakery gave the resultant design throughput for the wet-mill plant of 3633 loaves per hour. This rate had to be transformed into a wet-mill dough rate (slightly less wet-mill dough is required per 700g loaf than for flour dough) and a wheat supply rate. These figures are tabled below:

Variables	Values	Comment
Wheat per 700g loaf (g)	460	1
Dough per 700g loaf (g)	757	1
Actual loaves per hour	3633	2
Kg dough per hour	2750	
Batch size (kg)	300	3
Total no. wet mill loaves	10000	
Wet mill process rate (batches per hour)	4.8	4
No. of mixers for average loading	1.91	
Actual number of wet mill mixers	2	
Number of loaves per batch	396	5
Required number of batches	26	6
Total wheat required per day (kg)	4,600	6
Rate of wheat used per hour (kg/hour)	1671	7

Model: Wet-mill dough parameters (note: white cells indicate inputs)

Some explanatory notes which explain the assumptions or sources of information for the above calculations are listed below:

¹ 'Actuated' is used to describe a machine that starts only when it senses that product is present.

- 1 From recipe optimisation (see chapter 5)
- 2 From plant process flow table
- 3 Standard mixer as per plant process
- 4 10 minutes mixing, 2 minutes to load, 30 sec to swap bowls
- 5 Based on 757g per loaf and batch size of 300kg
- 6 For 10000 loaves
- 7 Based on 460g wheat per loaf and a batch size of 300kg

Notes: Wet-mill dough parameters

In other words the wet-mill cutter had to process 2750kg of dough per hour, which translated into a feed rate of 1671kg wheat per hour, or a daily requirement of 4.6 metric tons of dry wheat.

The next step was to size the upstream equipment to supply these rates of dough and wheat to the wet-mill process.

8.3. SCHEDULING THE WET-MILL PROCESS

Some assumptions had to be made with respect to the manner in which the wet-mill bread would be introduced into a plant bakery environment. The first assumption was that there would be two mixers, each doing 4.8 batches per hour. The second was that the total of 10000 loaves would be completed in two runs: one in time for the morning trade and one in time for the afternoon trade. The third assumption was that these two runs would occur one per shift which would make the addition of a third shift (and thus 33.33% increased capacity) very manageable. The table below summarises the details required from mixing in order to schedule the rest of the process.

Mixing	Assumptions	
Mixing time (min)	162.5	1
Mixing time (hr)	2.7	
Number of runs	2	2
Length of run	1.4	
Time between runs (hrs)	8.0	3

Model: Wet-mill mixing parameters (note: white cells indicate inputs)

A schedule was then compiled to meet the pull demand from mixing. It was noted that the equipment required to do two shifts of work was exactly the same as that required to do three shifts. If, however, a fourth run was to be added, extra silos and cleaning equipment would be required.

8.4. SIZING OF UPSTREAM EQUIPMENT

From the schedule it can be seen that the utilisation of the upstream equipment is high, at 79% for the cleaning system, and 90% and 92% for silo 1 and 2 respectively over the 48 hour modelled window.

8.4.1. Cleaning

Due to the assumption that there will be 2 runs to complete the 10000 loaf demand, a single cleaning plant will suffice. The plant has been sized as requiring a design throughput of 423 kg/hour, which was a small facility.

Cleaning	Assumptions	
Cleaning time (hours)	8	1
Wheat per run (kg)	2370	2
Efficiency	70%	3
Wheat per hour	423	

Model: Sizing of cleaning process (note: white cells indicate inputs)

The assumptions noted in the model are:

- 8 hours available cleaning time per run as per schedule (refer to 1 above).
- 396 loaves per batch, 460g wheat per loaf (refer to 2 above).
- An operating efficiency of 70% was selected, which was reasonable, given that cleaning equipment generally requires regular maintenance (refer to 3 above).

8.4.2. Soaking

The soak silos were trickier to size. Various assumptions had to be taken and are described below in the snapshot of the model.

Silo		Assumptions
Required mass wheat	3343	1
Max % water	69%	2
Max mass water (kg)	2307	
Total mass	5650	
Bulk density wheat (kg/m ³)	720 - 790	3
Bulk density wet wheat	715	4
Specific gravity of wheat	1.4	
Ingredient volume SG (m ³)	4.69	5
Ingredient volume BD (m ³)	4.68	6
Ullage	30%	7
Total volume SG (m ³)	6.10	8
Total volume BD (m ³)	6.08	9

Model: Sizing of wheat silos (note: white cells indicate inputs)

The assumptions noted in the model are described below:

- 1: Wheat per 1.4hr run is 2370kg, and per 2hr run is 3343kg, as determined above in sizing the cleaning equipment.
- 2: The maximum quantity of water that can successfully be added before the dough collapsed was 69%, as per experiments in Chapter 5.
- 3: Standard bulk density for BPS - BP2 grades of wheat (see Chapter 4).
- 4: Measured bulk density of soaked wheat.
- 5: Pro rata calculation with specific gravity of water as 1000kg/m³ and wheat as 1400kg/m³.
- 6: Sanity check using the measured lab result for the bulk density of wet wheat.
- 7: Required ullage to ensure a good mix (borrowed from Mother knowledge in Tea and Dry foods plants)
- 8: 4.33m³ for 5000 loaves or 1.4 hours production, or, 6.10 m³ for a full 2 hours production.

- 9: 4.31m^3 for 5000 loaves or 1.4 hours production, or, 6.08 m^3 for a full 2 hours production.

From the schedule it can be seen that a single silo feeds the cutter for the entire run. This means that the silo will be occupied not only during the chilling phase but also during the cut itself. Thus the wheat will have soaked at ambient for 14 hours, chilled for two where it may absorb the remaining quantity of water (depending on the chilling method employed). The first wheat to be cut will therefore have been soaked for a minimum of 14 hours and a maximum of 16 hours, and the last wheat to be cut will have been soaked for a minimum of 16 hours and a maximum of 18 hours, which is all within the specification detailed in Chapter 5.

It was decided to size the silo for a full 2 hour run, to allow the production facility flexibility in scheduling the runs. For instance they may need to run for 2 hours in the morning and 0.8 hours in the afternoon instead of two 1.4 hour sessions. This means that the silo must have a working capacity of 6.2 m^3 and be able to bear a full load of 5650kg (as can be seen in the model above).

The next 2 chapters will complete the design of the wet-mill equipment required to integrate into a plant bakery. Chapter 9 will look in detail at the process equipment required for cleaning and soaking the wheat. It will also determine the services requirement of the plant, such as compressed air and refrigeration. Chapter 10 will examine the physical and process integration of the equipment. It will determine how much space is required and what sort of transport and storage equipment would be required as well, as any changes to operating procedure.

9. PROCESS EQUIPMENT DESIGN

Following the process design, it can be seen that a capacity of approximately half a ton of wheat per hour is required with a batch requirement of approximately 3.5 tons of wheat every eight hours.

9.1. CLEANING

A large cost saving can be achieved by having the wheat delivered directly. This requires a cleaning process. There are many off-the-shelf cleaning systems. The key variable that manufacturers need, to design a specialized system, is the rate at which the product needs to be cleaned. There is a trade off between fast, and therefore expensive, cleaning systems and a slower inexpensive cleaning system.

The scheduling has taken deliberate advantage of the time available between batches to maximise the time for cleaning. An eight hour allowance for cleaning means that a small plant with a throughput of only 0.5 tons per hour can be utilised.

The large branded suppliers do not, however, manufacture such small cleaning plants, their minimum throughput being 2.5 tons per hour. Their specifications, as can be expected, are robust and conform to export standards. This has particular importance with respect to the cleaning of wheat from the Eastern and Northern Free State which contains the small thorny black '*Kankerros*' fruit. This fruit, when broken open, has seeds with a high content of the *afatoxin*¹. This toxin is more commonly known as a 'peanut' sensitivity. Any export to the United States of America must have *afatoxin* in quantities less than 5µg/kg (5 parts per billion!).²

Buhler's standard 'simple' cleaning plant retails for about R300,000 which includes a rubble separator, a de-stoner and a Trier (an indented drum separator specially designed to remove other seeds and fruit as described above). The more deluxe version comes with an in-line weigher (necessary for yield management and quality control verification of wheat grading) and a scourer (carborundum disks that rub off the

¹ Kent, Jones and Amos, Modern Cereal Chemistry, 1981

² Interview with Mr Grant, Senior Technician, South African Bureau of Standards, August 2003.

outer layer of bran husk and aspirate it off). This version costs R800,000 including the air plant required to supply the LP 10m/s air to operate the aspirators¹.

9.2. CHILLING

The chilling requirements of the process required a number of investigative stages. Firstly the specific heat of wheat had to be calculated. Then various refrigerants had to be investigated to determine which would be easiest and most cost effective to use. Once the refrigerant had been chosen, scenarios had to be run to confirm whether the process would be robust enough to handle the temperature variations that would be experienced in the field.

9.2.1. Specific Heat of Wheat

Before the total heat load for a batch could be calculated, the specific heat of wheat had to be determined. This was done using two controlled experiments, the outputs of which are described below. As can be seen the two experimental results are very close. The higher value will be used to be conservative.

Specific heat of wheat		
	Exp1	Exp2
Water KJ	38	84
Water kg	1.8	1.8
SH Water	4.22	4.22
Delta t	5	11
Wheat KJ	38	84
Wheat kg	3	3
SH Wheat	4.22	4.00
Delta t	3	7
Balance	0	0

Model: Calculation of wheat's specific heat (note: white cells indicate inputs)

¹ Discussion with Henry Render, Technical Manager Buhler Milling division July 2002.

9.2.2. Investigation of Various Refrigerants

A number of refrigerants were investigated, namely: ice, carbon dioxide, ammonia and nitrogen.

Ammonia was quickly discarded for both safety and cost reasons. The capital installation required for the operation of an ammonia refrigeration system is large, and ammonia has a very high heat of compression resulting in hot discharge gasses. Ammonia must operate within a closed refrigeration cycle (it is illegal to release ammonia gas into the atmosphere) and so there is a need for compressors to re-liquefy the ammonia gas. The second reason for its elimination was that ammonia is a serious health hazard: not only is it toxic to humans (affecting all soft tissues areas as an irritant), but it has a powerful aroma which would affect the taste of the product. The ammonia cycle would therefore have to be kept separate from the product cycle which infers cooling through some sort of exchanger – an inefficient way of chilling.

Ice was not initially very interesting, until scale ice was investigated. Scale ice has some advantages: firstly it can be shaved off at a temperature of minus six degrees; secondly it was very cheap to produce. A medium capacity ice plant would cost only R50k which compared favourably to the installation costs of nitrogen and carbon.

From a safety and hygiene point of view, ice, carbon dioxide (CO₂) and nitrogen (N₂) were all found to be safe enough for both the product and human interaction. It could be argued that CO₂ and N₂ pose occupational hazards, but this is generally only a concern where very large quantities are being used, which is not the case here. All of the above, therefore, could be introduced directly into the product (thereby optimising heat transfer) without any product safety ramifications.

The chilling capacity of each of these substances was next investigated and, as can be seen from the model below, liquid CO₂ provided slightly better capacity per kg at 600 kJ than the other two.

KJ chilling/kg	Ice	CO2	N2	Notes
	465	660	658	
Specific energy solid	13	-	-	1
SH solid	2.10	-	-	
Chilling kg	1	1	1	
Temp diff	6	-	-	
Ice temp	(6)	(76)	(196)	
Melting temp	-	(76)	(196)	
Latent energy (S → L H2O; L→G N2; S→G CO2)	330	571	199	2,3,5
LH	330	571	199	
Chilling kg	1	1	1	
Specific energy liquid H2O or gas for CO2 N2	122	89	459	2,3
SH liquid	4.22	1	2	
Chilling kg	1	1	1	
Temp diff	29	105	225	
Melting temp	-	(76)	(196)	
Final temp	29	29	29	4

Model: Chilling capacity of various refrigerants (note: white cells indicate inputs)

Some explanatory notes which describe the assumptions or sources of information for the above calculations are listed below:

- 1 Only ice has a solid phase which is available for cooling. Solid CO2 flashes off too quickly.
- 2 Ref: BOC Gases' Material safety data sheet no. 994-305: Liquid Nitrogen
- 3 Ref: BOC Gases' Material safety data sheet no. 994-324: Carbon Dioxide
- 4 Optimal temperature for dough to be at after mixing is 29 C
- 5 S= solid, L=liquid, G= gas

Notes: Chilling capacity of various refrigerants

If however the cost profiles are looked at, it then becomes obvious that ice should be used. As noted below, the ice incurs no extra variable cost as it has already been costed as an ingredient.

Chilling Load of 1000kJ	Ice	CO2	N2	Notes
Chilling capacity (kJ per Kg)	465	660	658	1
Mass required for 1000kJ	2.15	1.52	1.52	
Cost per kg (Rands)	-	0.80	0.40	2
Cost per 1000kJ load	-	1.21	0.61	3

Model: Cost of various refrigerants (note: white cells indicate inputs)

- 1 Chilling capacity as calculated using data from BOC
- 2 From Afrox Suppliers Oct 2000 pricing
- 3 Note that ice has no variable cost as water is an ingredient

Notes: Cost of various refrigerants

9.2.3. Chilling Scenarios

Although it was clear that ice was the way to go from a cost point of view, it was not clear whether the process could afford to give up so much water. As chilling energy calculations are based on the total quantity of product, the percentages of water and wheat in relation to dough had to be calculated. A 65% water content, the lower of the 65%-69% confirmed in the recipe optimisation of Chapter 6, is actually the percentage of water to dry wheat, whereas it is only 39% of the total dough. The model below should make this clear:

	Mass (kg)	% Wheat	% Dough
Wheat	3	100%	61%
Water	1.95	65%	39%
Dough	4.95	165%	100%

Model: Wheat, water as % of dough (note: white cells indicate inputs)

Three scenarios were tested: the first assumed that the soaked wheat started at an ambient temperature of 22°C and was allowed to increase in temperature to 29°C. The second started and ended at 29°C which means that all the input mechanical energy that was passed on to the dough would have to be removed through the input of scale ice. The third scenario assumed as a worst case situation that the wheat's initial temperature was an elevated 35°C. This meant that the chilling would not only have to take out the equivalent of the mechanical energy, but it would also have to reduce the temperature of the dough by 6°C.

The input mechanical energy was determined as:

Input mechanical Energy = mass x specific heat x change in temperature

As the chilling was performed on the same mass of product for the same amount of time, then the energy input stays constant and can be reflected as just the temperature rise that would have taken place had the refrigerant not been there. Thus in scenario three the total ΔT is the mechanical energy input plus the extra chilling of the product from 35°C to 29°C, a total of 14 °C + 6 °C = 20°C, ignoring heat losses to the surroundings.

In the soak experiments, the total percentage (65% of dry wheat mass) of water had been added to the dry wheat. After the soak was finished, there was, on average, about 20% of the water left over that had not been absorbed by the wheat. This provides a degree of comfort when interpreting the results of the 'normal' and 'bad'

scenarios. Only 12% and 16% (of dry wheat mass) respectively of the water is needed for conversion into scale ice. In other words 'spare' water is available to be used as scale ice and thus there is no possible impact on the upstream process. However in the worst case scenario 25% (of dry wheat mass) scale ice is required. This raises two issues. Firstly, if this amount of water is deducted from the water available for soaking, then the mixing upstream has to be consistent and even, so that no dry spots of wheat occur. This will limit the impact of a 5% decrease in the water available for soak. Secondly, it would be advisable on hot days to add chilled water to the wheat instead of ambient water. This will reduce the temperature of the soaked wheat coming in to be mixed and thus the heat load on the chilling plant.

A last comment on the model: an 'inefficiencies' line item was built in to the model to account for losses in a real-world application of the refrigerant. For instance, a large portion of the CO₂ and N₂ would flash off before it had any useful impact on the chilling of the product. The figures used were obtained in discussion with suppliers, based on their experience with each of the refrigerants. The model uses 1 to indicate 100%, and for any number great than one, the inefficiency is that number's reciprocal, e.g.: 3 → 33.33%.

	Normal	Difficult	Worst	CO2	N2	Notes
Price/loaf	-	-	-	0.069	0.020	
Loaves/batch	130	117	110	130	130	
Price/batch (Rands)	-	-	-	8.92	2.56	
Price/kg	-	-	-	0.80	0.40	9
kg refrig. required/batch	7.08	9.64	15.36	11.15	6.39	8
kg refrigerant/loaf	0.05	0.08	0.14	0.09	0.05	
Conversion IN-efficiency	1.2	0.8	1.0	2.5	1.4	7
KJ load	2,745	5,338	7,143	2,945	2,945	
Product SH	4.22	4.22	4.22	4.22	4.22	6
Product (batch excl ice) kg	92.92	90.36	84.64	100.00	100.00	
Temp diff	7	14	20	7	7	
Temp start	22	29	35	22	22	5
Temp end	29	29	29	29	29	
Energy input from blades	14	14	14	14	14	4
Ice as % wheat	12%	16%	25%	0%	0%	
Ice as % dough	7%	10%	15%	11%	6%	
Total batch (kg)	100	100	100	100	100	3
Wheat in batch	61	61	61	61	61	2
KJ chilling/kg refrigerant	465	465	465	660	658	
Specific energy solid	13	13	13	-	-	
SH solid	2.10	2.10	2.10	-	-	1
Chilling kg	1	1	1	1	1	
Temp diff	6	6	6	-	-	
Ice temp	(6)	(6)	(6)	(76)	(196)	
Melting temp	-	-	-	(76)	(196)	
Latent energy	330	330	330	571	199	
LH solid	330	330	330	571	199	1
Chilling kg	1	1	1	1	1	
Specific energy liquid	122	122	122	89	459	
SH liquid	4.22	4.22	4.22	0.85	2.04	1
Chilling kg	1	1	1	1	1	
Temp diff	29	29	29	105	225	
Melting temp	-	-	-	(76)	(196)	
Final temp	29	29	29	29	29	

Model: Scale ice scenarios (note: white cells indicate inputs)

Some explanatory notes which explain the assumptions or sources of information for the above calculations are listed below:

- 1 Ref: BOC Material safety data sheets nos. 994-305/24
- 2 Off table above - dependednt on % water
- 3 Total dough quantity of 100 kgs
- 4 Reflected as temperature (C) increase in dough
- 5 Various temp input scenarios
- 6 As calculated previously
- 7 Inefficiencies where 1=100% and 3=33.33% efficient.
- 8 Calculated kg refrigerant requirement
- 9 Affrox supplier costs Oct 2000.

Notes: Scale ice scenarios

9.3. SOAKING

Initially, the soak process vessel was required to soak a mass of dry wheat in 60% of its mass of water. It was also initially thought to make the process continuous in anticipation of an entire bakery conversion. After it was decided to use scale ice as the refrigerant, a uniform soak became the more critical variable. The section below describes the steps taken to design a rotating soak vessel that would meet the new batch process system that had been decided upon.

9.3.1. Continuous Soak Design

In order to achieve a continuous supply, two designs were proposed. The first was a submerged conveyor; the second was a bucket elevator.

The first idea was to design a system that could be used for a plant that had totally converted to the wet-mill process. A basic model of the conveyor was designed in order to understand how large it would have to be.

Conveyor	Values	Notes
Rate of wheat used per hour (kg/hour)	1671	1
Rate of wheat per second (kg/s)	0.46	
Bulk Density of wet wheat (kg/m ³)	715	2
Rate of wheat per second (m ³ /s)	0.0006	
Minimum soak time (hrs)	14	3
Minimum soak time (s)	50400	
Conveyor width (m)	2	4
Conveyor depth (m)	0.3	
Conveyor cross-sectional area (m ²)	0.6	
Conveyor speed	0.0011	
Conveyor length (m)	55	

Model: Continuous soak conveyor (note: white cells indicate inputs)

Explanatory details for the notes above are described in the table below:

- | |
|--|
| <p>1 Based on 3633 actual loaves per hour and 460g wheat per loaf
 2 Measured bulk density of soaked wheat in the lab.
 3 As discussed in chapter 5, wheat soak optimisation
 4 Reasonably sized wide shallow conveyor</p> |
|--|

Notes: Continuous soak conveyor

As can be seen above, the conveyor is huge. A length of over 35m is required in order that a soak time of 9 hours is achieved. If the full length soak time of 14 hours was decided upon for safety reasons, the conveyor becomes a ludicrous 55m long.

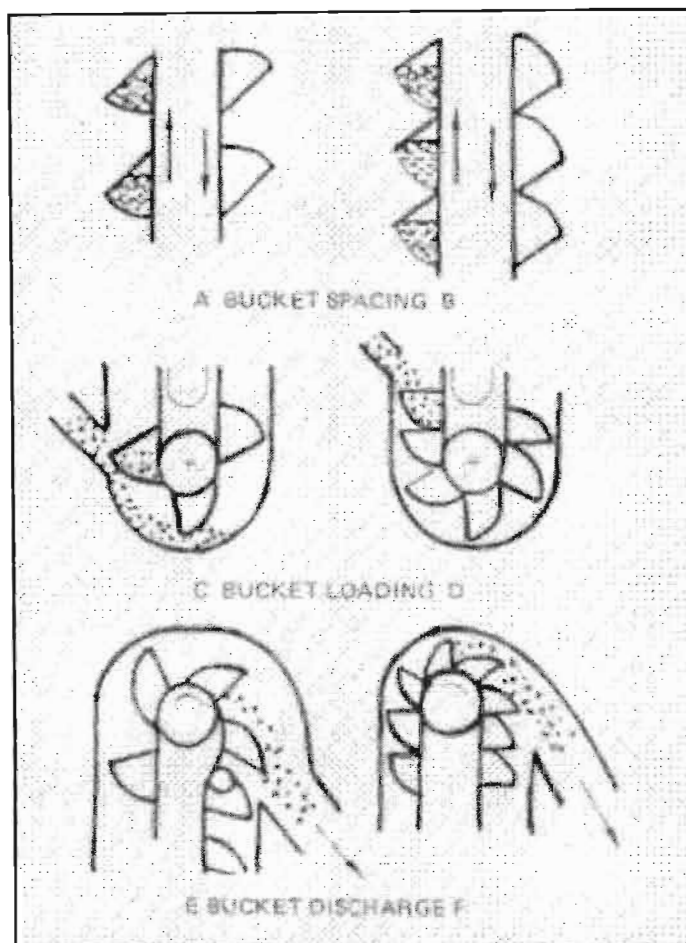
This inefficient space utilisation could be resolved by going vertical (instead of horizontal). A possible conveyor system was investigated. There are three broad categories of conveyors, namely screw, en masse, and bucket. Screw conveyors were decided against because the flights or screw is not sealed, and in going vertical the soak water would remain at the bottom of the pipe. The en masse had a similar problem – it is a system that is usually used for heavy and large 'lump' size products such as coal.

A bucket elevator seemed the best option. There are two distinct categories of bucket elevators; the continuous discharge (spaced buckets as in A below) and the centrifugal discharge (see diagram B in the sketch below) type. The centrifugal type bucket is used for free flowing or granular products. Its name arises from the discharge of the product which occurs at the head of the elevator where, as the bucket passes over the head, the product is discharged by centrifugal forces (see picture F below).

It is this characteristic that causes this design to be eliminated as, in order to create sufficient centrifugal force, the speed of the carrying chain must be between 1.2m/s and 2 m/s¹. The continuous design, however, is generally much slower and can handle high loading factors; it is usually a large mass flow device. A smaller lighter conveyor could be designed but it will cost extra as the conveyor will be a non standard item.

The bucket elevator therefore could be used as it is a positive displacement device that could hold a portion of soak water in each bucket. However, the system would be difficult to manage and calculating yields would be a nightmare.

¹ Bulk Conveying principles and practice pg12, 1996 Selenco Equipment manufacturers (Pty) Ltd



Sketch: Continuous discharge (left) vs. centrifugal discharge (right) conveyors

It was also unrealistic to think that an entire mill would convert to a new process. It would be much better to design a soak vessel that could be duplicated to provide extra volume i.e.: something that would provide capacity flexibility.

In a continuous system, at any one moment in time there is 9 hours of production sitting as working capital or product that could be placed at risk as a result of production stoppages. A batch system only ever has the volume of each 4 hour run on hand.

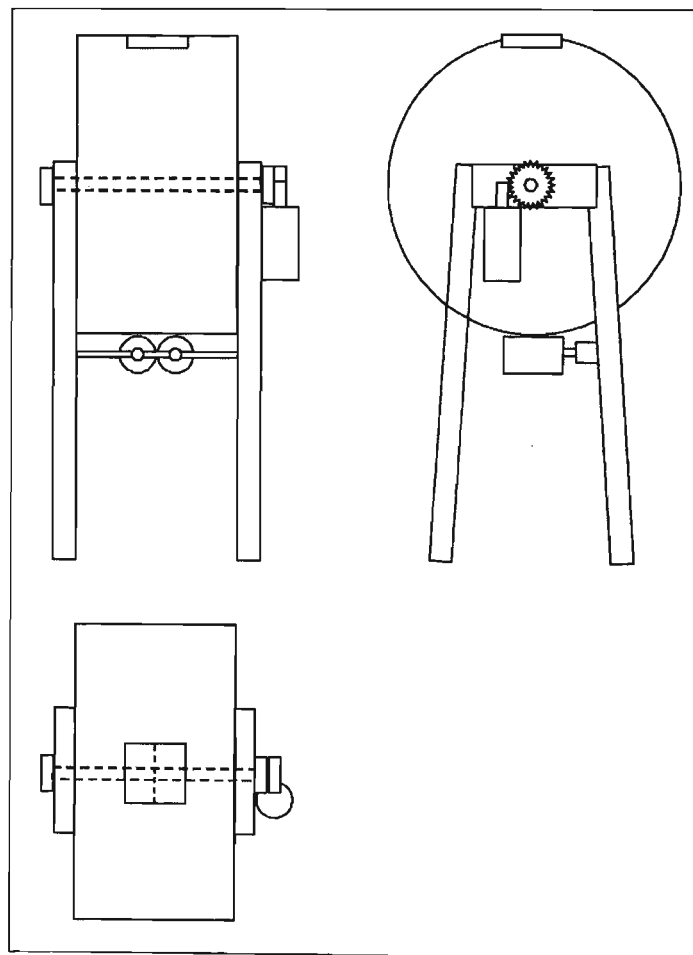
9.3.2. Batch Soak Design

The decision to go with scale ice, together with the variability it introduced into basic ingredients dosing, resulted in a need to standardise the production. If a fixed 45% of the water was added as soak water, it would allow the flexibility to introduce up to 25% of the water ingredient as ice. If, however, the dough temperature does not require

such a high percentage of scale ice, then the remainder of the water ingredient could be added at ambient temperature.

If the temperature of the wheat rises above 29°C, then the water that is added to the dry wheat (i.e.: the soak water) should be from the Plant Bakery's chilled water supply. This will ensure that the temperature of the wheat entering the mixing process is always below or equal to 29°C.

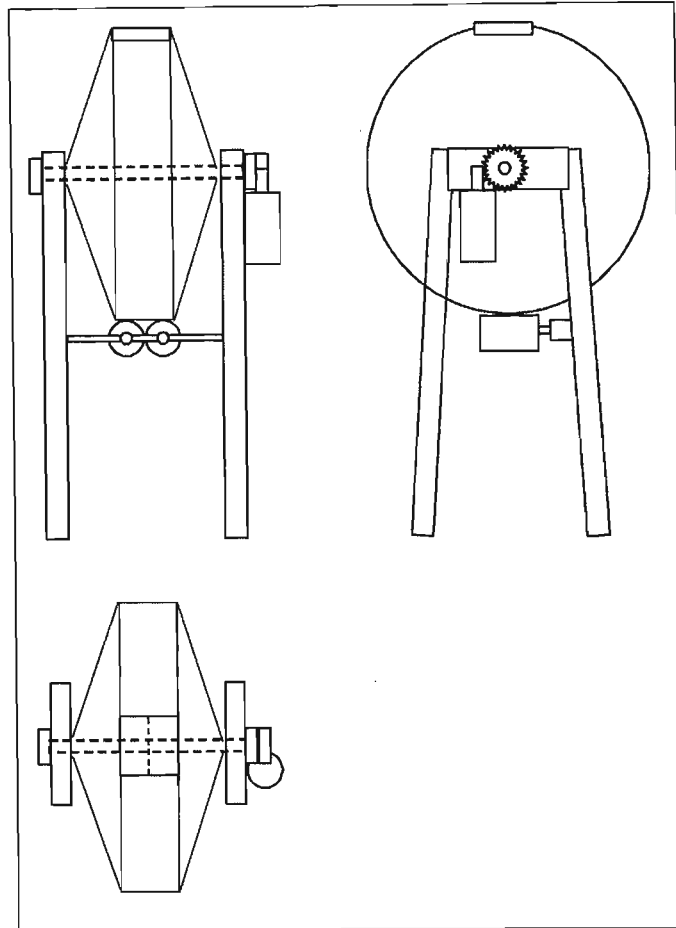
The design of the vessel itself was initially based on the design of a vessel successfully used in the tea industry: a rotating drum, which is easy to build and will ensure an even soak while at the same time facilitating agitation during the soak.



Sketch: Drum soak vessel

The rotating drum as depicted in the sketch above had a number of flaws; it became patently clear that the extraction of the wheat from the vessel was going to be difficult. The second major issue was that none of the soak water could be left behind, otherwise yield calculations and recipes became pointless; the same issue arose in that there was no easy way to wet-clean and drain the vessel.

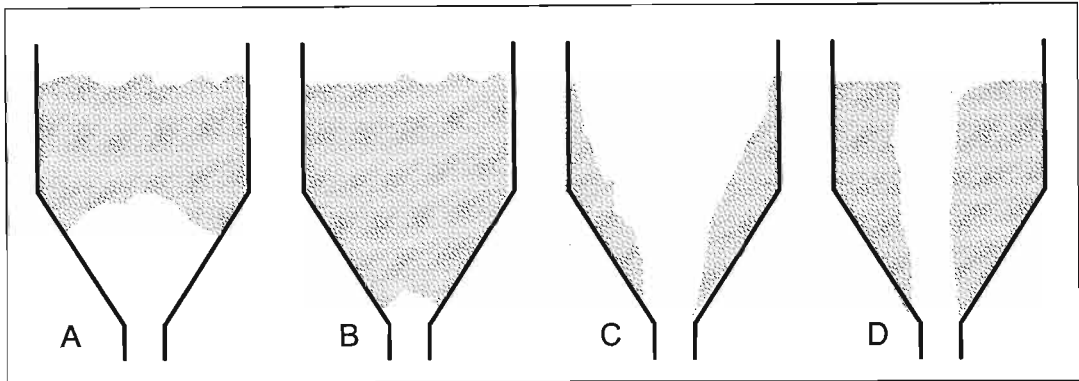
The next idea was to put in a correct flow taper to the drum. And, as can be seen in the sketch below, it turns into a very impractical vessel. Not only does it inefficiently use its footprint volume, but it would be very expensive to fabricate.



Sketch: 'Coned' soak drum

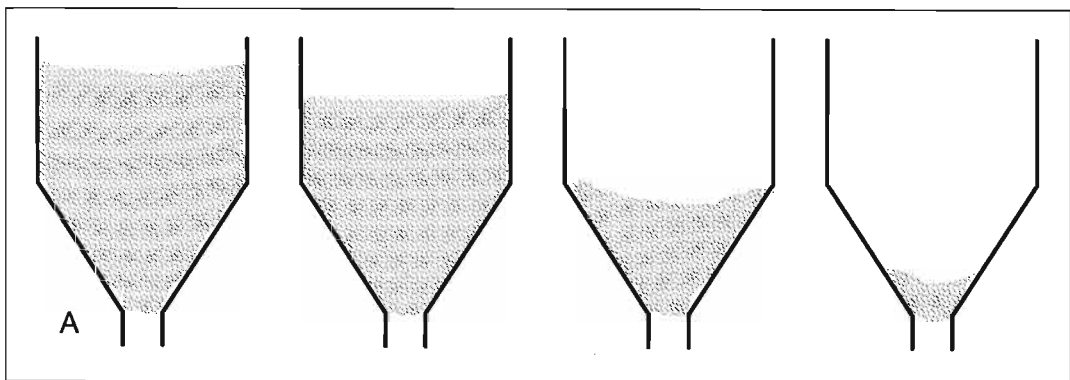
The storage vessel also had to abide by the standard mass flow characteristics of the product. There are two common problems associated with incorrect design of this sort of vessel: bridging, and rat-holing. Bridging results in the formation of an arch or bridge across the opening of the hopper. The strength of the bridge is such that it supports the total load of the material above it. Bridging (see B in the sketch below) occurs when the outlet diameter is too small on the basis of a calculated minimum diameter D_{min} required to affect uninterrupted flow. The form of bridging called arching (see A in the sketch below), where the arch transfers the load to the hopper walls, applies so much pressure to them that the kinetic coefficient of pressure Φ becomes so great that the bridge prevents any flow from the vessel. Force must then be applied to the arch so that it collapses and flow restarts, even if erratically. In sunflower milling, the left over wet husk parts are stored in silos equipped with knockers which continually tap the bottom of the cone to prevent bridging.

Rat holing is characterised by the formation of a channel (D in the sketch below) through the solid mass and is the result of incorrect selection of cone angle. Rat-holing can occur even if D_{min} is correctly sized. See the sketch below for examples of rat holing and bridging. C depicts the mass flow effect of 'clinging' – dead zones where no flow occurs.



Sketch: Rat holing and bridging

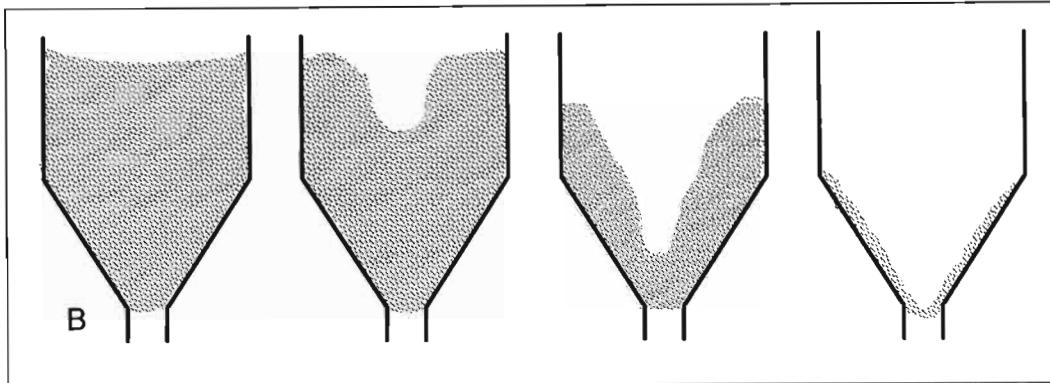
There are two broad types of flow influenced by the design problems described above: mass flow and funnel flow. Mass flow is the most sought after feature of a storage vessel: unassisted flow whenever the bottom gate is opened. Mass flow from a bin implies that the total volume is in motion – in other words, uniform and steady-state flow can be attained. A mass flow bin is devoid of channelling, surging and bridging. The flow is also independent of the head of the stored solids, with a minimum consolidation of product and no dead space. The flow from a mass flow bin can be described as first in → first out. A sketch of mass flow is included below.



Sketch: Mass flow

Funnel flow, on the other hand, occurs when only a portion of the material flows when any material is withdrawn. Flow occurs in a channel in the centre of the bin and is always from the top of the stored solids to the centre. During the flow of the solids through the channel, a dead zone occurs in all other parts of the bin. Funnel flow

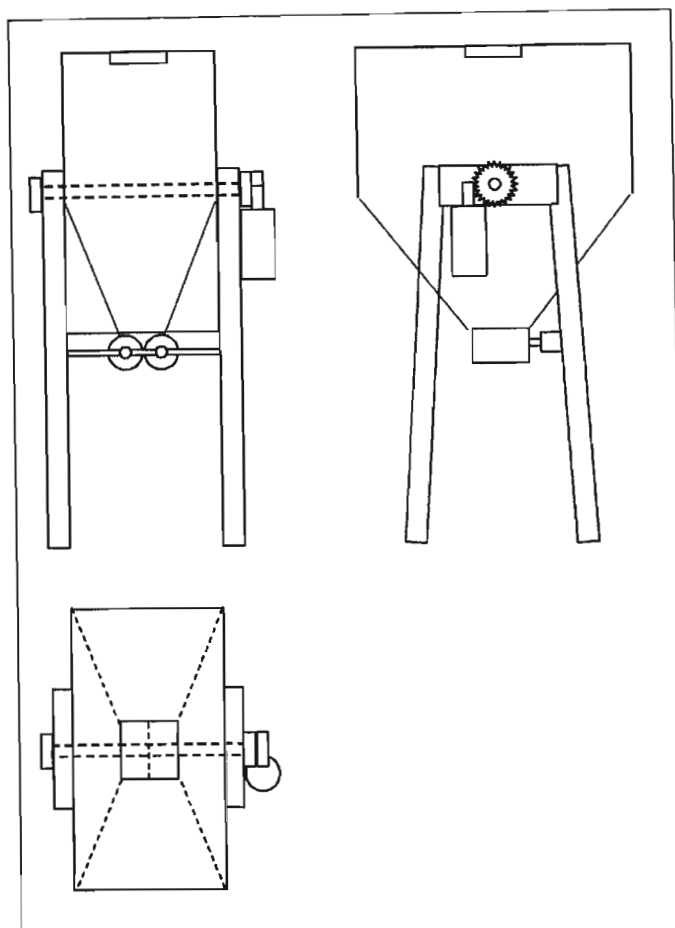
leads to first in → last out and has disadvantages such as flooding, material degradation, and consolidation. A sketch of funnel flow is included below:



Sketch: Funnel flow

It thus became necessary to measure the angle of repose. The angle of repose of the wet, soaked wheat was measured and found to be 45° . The bulk density is 710kg/m^3 as discussed earlier in the thesis, and the total volume 6.2m^3 .

The final soak vessel design rotates, and has a correctly sloped cone at one end. It will be equipped with easily cleanable, sterile baffles to thoroughly mix the wheat and water. The final soak vessel would look something like the sketch below.



Sketch: Rectangular soak tank with taper

The following are key elements of this design.

- A single slide-gate allows top loading and bottom off-loading. This design is not only cheaper to build but also has fewer wearing parts which means less maintenance.
- Baffles prevent product build-up during off-loading. The baffles would have to be correctly designed to ensure that the product is forced to mix thoroughly.
- The drum can be easily washed out for non-operational periods. All debris will be washed into one of the mixing bowls parked beneath the open chute.

A further modification was introduced to the soak vessel. During the lab optimisation phase, there was a roller drier next to the wet-mill rig. If the steam supply to the roller drier was turned off, the large steel rollers could be used as 'flatteners.' A brief trial was undertaken to roll the wheat before it was cut. What was interesting was that this combination produced a super-fine cut. It was postulated that the increased cross-sectional area gave the blades more area to cut, more often, resulting in a finer cut.

The inertial mass route was also tried as an explanation, but inertial mass had only increased in one direction and there was no way of ascertaining whether the grains lay more than 50% in the direction of increased mass.

For the scaled-up design it was decided that flattening rollers should therefore be installed beneath the out manhole of the soak vessel. The rollers would not only help provide a fine cut - but they would also serve to control the feed rate for accurate dosing into the bowl for mixing.

10. WET-MILL PHYSICAL INTEGRATION

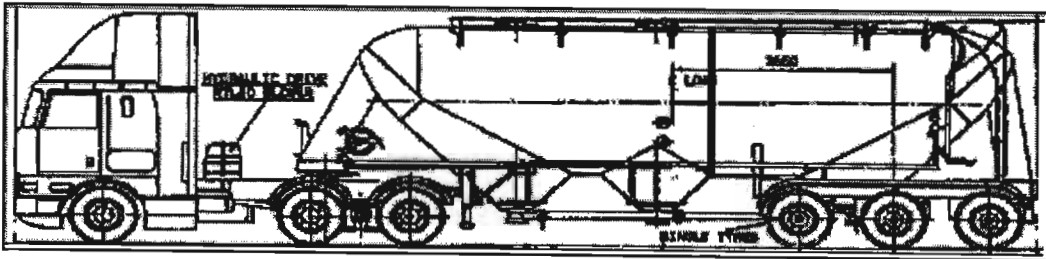
The wet-mill process introduces a number of complexities into the bakery. Firstly there is whole new inbound supply chain that needs to be managed efficiently and effectively as there is no flexibility (system slack) when working with a perishable food product. Inbound logistics had to be investigated to ensure a feasible, reliable and hygienic supply of wheat. Thus a robust system of loading the wheat from the mill, transporting and offloading it at the bakery had to be thoroughly mapped out. The second aspect of the integration was the storage of the wheat at the bakery and whether an existing or new silo had to be dedicated to wheat. The wet-mill plant had to also be physically integrated into the existing bakery and the space it occupied optimised, so as not to impact on existing bakery processes.

10.1. INBOUND LOGISTICS

10.1.1. Transport

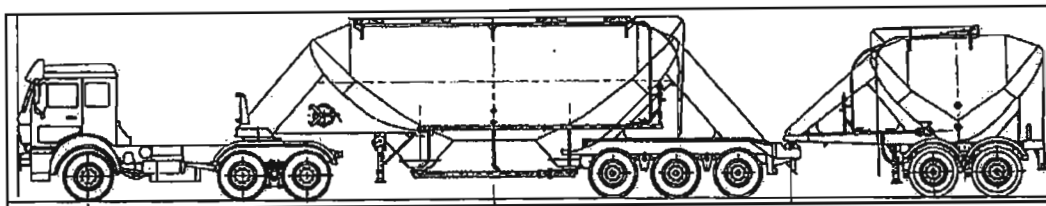
There are two key transport risk areas: the actual vehicle-transportation of the wheat, and the offloading of the wheat at the bakery.

In consultation with Les Uppink¹, there are three ways of solving the vehicle-transport problem. Firstly an existing flour truck could have a baffle plate installed to separate flour from wheat and then partial wheat loads can be transported to the bakery.

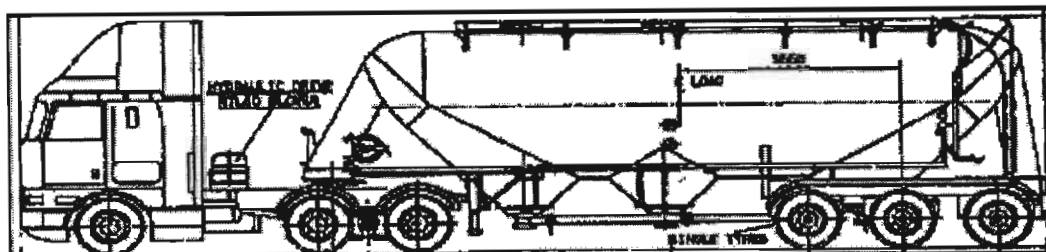


Sketch: Transport option 1

¹ Manager of MAKbodies, premier South African supplier of flour truck conversions.



Sketch: Transport option 2



Sketch: Transport option 3

The second option is to have a dedicated pup that is attached to the normal flour delivery. The third option is to have an entire truck converted to the use of wheat only. All three options are sketched above.

10.1.2. Loading and Offloading

The wheat will first need to be loaded onto the truck. This step incurs two issues: possible starvation of the mill and difficulty loading the truck from usually road-remote storage silos (wheat is normally delivered to the mills by train)

In order to understand this step in the process, time was spent at Sasko's Mobeni flour mill. The mill operates at 10tph. It is a continuous 24 hours per day, 7 days per week operation. Cleaning has a maximum throughput of 14tph. Thus only 4tph could be bled off without affecting the mill's operation. A spare storage silo would probably have to be dedicated to buffering the stock so that trucks are not kept waiting. A loading mechanism to transfer the wheat into the silo would have to be designed (a simple pneumatic system would suffice such as the commercially available 'flowveyor').

The mill is not designed to offload wheat. Most wheat storage silos would be near a rail offloading point and not necessarily near a road. Because the trucks are top loaded, the wheat would have to be first gravity bled from the cleaned wheat silos and then lifted via a driven device to the waiting truck.

10.1.3. Storage

On integration into an existing facility, wheat storage depends on available silos and the amount of bread to be produced at the chosen bakery.

After playing with an excel model of a plant bakery it was determined that, for instance, in a 10 000 loaves/day bakery with more than 8 silos, it is possible to dedicate one silo. If it has less than 8 silos then there would be a need to install a new 10 ton silo. In a 15 000 loaves/day bakery with more than 5 silos one silo can be dedicated. However, if it has less than 5 silos a new 15 ton silo will have to be installed.

Dedicating a silo requires no conversion other than ensuring that the bakery compressor is big enough to pneumatically convey dry wheat as well as flour. In the capital equipment schedule in Chapter 13, the worst case scenario costs a new compressor.

10.2. PHYSICAL INTEGRATION

The wet-mill plant had to be physically integrated into the existing bakery and the space it occupied optimised so as not to impact on existing bakery processes. The previous section has already covered off the physical requirements of wheat offloading and storage. This section will examine the physical requirements of the wet-mill chilling and mixing plants.

10.2.1. Chilling

The chilling requirement as described in Chapter 10 can be supplied by a number of scale ice machines. These are off-the-shelf self contained plants with an input of water board water.

Chilling		Assumptions
Wheat per hour (kg/hr)	1671	1
Dough per hour (kg/hr)	2757	2
Scale ice required at 7.08 % dose (kg/hr)	196	3
Scale ice required at 9.64 % dose (kg/hr)	266	3
Scale ice required at 15.36 % dose (kg/hr)	424	3

Model: Sizing of scale ice equipment

Explanatory details for the notes above are described in the table below:

- | |
|---|
| <ol style="list-style-type: none">1 Based on 3633 loaves per hour and 460g per loaf2 Dough is 165% x mass wheat3 Kg scale ice per 100kg product as per chilling requirement calcs |
|---|

Notes: Sizing of scale ice machine

As can be seen above we need between 200- and 400kg per hour for the 2 hour run per shift. Thus in 24 hours we need a total capacity of between 1200- and 2400kg scale ice. The Scotsman range of scale ice machines can easily supply this demand. A product data sheet of the MAR305ASR model is included in Appendix E.

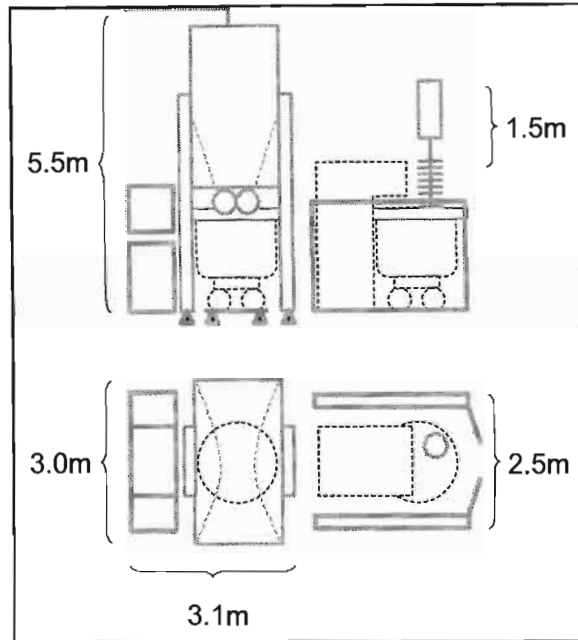
The Scotsman MAR icemakers are constructed in AISI 316 stainless steel for superior corrosion resistance, with heavy-duty components offering long life and tough dependability. A slowly rotating horizontal drum containing the evaporator is sprayed with fine water to create a layer of sub-cooled ice on the surface. A stainless steel ice blade then slices the ice off the unit, dropping it into the chosen storage bin or area.

The latest designs are very practical. For example, the Compact models feature ergonomic service panels giving easy access for maintenance, function LED's to allow users to easily check the machine's operating status, and rounded corners to ensure safety.

The fully integral design of the Compact models also gives maximum capacity in the minimum space, and use of the latest technology has allowed Scotsman to reduce the cabinet sizes of many models, allowing better use of tight spaces. For instance, the MAR 125 - a new mid-range Compact model - produces up to 1000kg per day yet measures just 1135mm (height) by 620mm (depth) by 875mm.

10.2.2. Wet-Mill Mixing

A rough schematic of the plant includes ice manufacture, soaking, flattening, and mixing. A detailed consideration of the design of the wet-mill cutter is discussed in the following chapter. In this layout, the mixer has been shielded behind extra protective walls to ensure operator safety.



Sketch: Process plant arrangement

Such machine guarding is precautionary and not necessary. The high speed rotating blades are enclosed inside a thick-walled mixing bowl. As an extra precaution, safety guards can be erected around the installation, so that in the unlikely event of a blade failure, and the even more unlikely event of one of the blades penetrating through the bowl, personnel will not be hurt.

10.3. OPERATION VARIABLES

Ice will be manually added to the bowl before mixing, guided by a table such as the one below:

	Ambient	% soak water	% Ice	% chilled water
Winter	26	45%	13%	7.00%
	27	45%	14%	6.00%
	28	45%	15%	5.00%
	29	45%	16%	4.00%
	30	45%	17%	3.00%
Summer	31	35%	18%	12.00%
	32	35%	19%	11.00%
	33	35%	20%	10.00%
	34	35%	21%	9.00%
	35	35%	22%	
	36	35%		

The table will have to be verified for the actual performance of the final scaled plant (the final wet-mill machine and mixers). The dosing should be easily controlled via a weigh scale upon which the bowl could sit. Chilled water is a standard ingredient in a bakery and so will be available from an existing supply in the mixing area. Notice that depending on whether there is an expectation of higher temperatures (e.g.: summer) the soak % changes. The wheat can soak up to 45% of its weight, and fully soaked wheat gives a better final dough. Note that the percentages are of the dry weight of wheat.

10.4. INTEGRATION INTO EXISTING PROCESS FLOW

Procedures do not have to change much.

10.4.1. Operator

As can be seen below, the mixing procedure has not really changed. What has changed, however, is that there is extra machinery to clean each day and new guarding to close before the machines can be started. This safety mechanism will be hard wired into the system, so that the machine can not be started unless the guards are closed.

Load bowl with ingredients	No change
Put bowl into Diosna	No change
Start mixer	No change
Start cutter	New
Remove bowl	No change
Place into lifting tipper	No change
Repeat whole process	No change

Table: operator procedure

10.4.2. Preparation, Cleaning

Step 1: Load soak silo with wheat, water & salt.

Step 2: Start silo motor sequence.

Or, for cleaning:

Step 1: Empty silo and relocate or dump wheat.

Step 2: Rinse silo.

10.4.3. Optimising Line Speed

Bowl usage (blade space) vs. Mixing time.

We have to balance this inverse relationship:

	8	9	10	11
60%	93%	83%	76%	69%
65%	100%	90%	82%	75%
70%	108%	97%	88%	81%
75%	116%	104%	95%	87%
80%	123%	111%	101%	93%
85%	131%	118%	107%	98%
90%	139%	125%	114%	104%
95%	147%	132%	120%	110%

Model: Bowl usage (%) x mixing time (min)

As can be seen from the above calculation, at a bowl usage of 70%, the final machine has to cut and mix in under 9 minutes (the shaded part of the model is where capacity of the wet-mill cut exceeds the plant bakery requirement of 100%).

10.4.4. Changeovers

Changeovers are the same as for brown to white bread:

- Using the same bowls
- Feeding into the same divider
- Filling in the same (or less) time
- Emptying in the same time

11. DESIGN OF A VERTICAL WET-MILL CUTTER

This chapter follows on directly from Chapter 6 where a successful 50kg rig had been built and tested. This chapter explains the design process and outlines the detailed customer design requirements. The design starts with the blades and then moves on to the shaft and the rest of the machine. The design of blades required finite element modelling which, for clarity's sake, has been extracted and isolated in the next chapter. Each design step is described in detail with sample calculations included in the appendix. The chapter ends with a discussion on design optimisation.

11.1. THE DESIGN PROCESS

Discussion on design follows two main points of view. The first, reflected in *Ulman's* work, is that any machine design is there to meet a need; and clear and thorough identification and quantification of the need is necessary to build an effective machine. The second is that the machine needs to function and be operated in a particular environment. *Juvinall*, for instance, talks about design 'in context.'

The technical considerations of design are largely centred on two main areas of concern

- Stress-strain-strength relationship involving the bulk of the solid part
- Surface phenomena including friction lubrication, wear and environmental deterioration.

When considering a complete machine, the engineer invariably finds that the requirements and constraints of the various components are interrelated. The objective of the design engineer is to determine an optimum design for a combination of related components.

However, in addition to the traditional technological and economic considerations fundamental to the design and development of mechanical components, there are broader stake holders to be considered.

*Juvinall*¹ states that “the objective of any engineering design is to provide a machine or device that will benefit humanity”. This is a commonly overlooked point of view when engineering design takes place. The design engineer should take into account the machine “in context” and consider issue such as safety, ecology and overall quality of life.

Safety is inherently a relative matter and value judgements must be made regarding the trade-offs between safety, cost, weight etc.

Ecological design takes into account issues such as:

- recycling,
- efficient use of resources,
- type of construction material (renewable vs. non-renewable),
- pollutant emissions

The design in this case probably has as its most serious offence noise pollution – which will be designed out, where possible, by using a properly dampened structure.

The Life Quality Index was developed by *Juvinall* to address the concerns of a broad set of stakeholders. This index largely defines the experience of the machine in relation to how it improves the quality of life. A good example of this is whether the machine design precludes a one armed person from using it.

In this design we are integrating into an existing facility and have thus used existing standard operating procedures and norms.

The design process that has been used incorporates both *Ulman* and *Juvinall* points of view, starting with the QFD (quality function deployment) process recommended by *Ulman*². The table below is an estimation of the customer (plant bakery) requirements. There are six key focus areas:

¹ Robert c. Juvinall, Fundamentals of machine component design, 1991, Chapter 1 pg10

² David G Ullman, The mechanical design Process, 1992, Chapter 7 pg 115-121

- **Functional Performance:** What is the primary need that the machine has to meet? In this case it has to mix the dough in 9 minutes.
- **Spatial Constraint:** This machine has a number of spatial constraints. Not only does it have to mix in an existing plant bakery bowl, but it also has to mix in-situ, so that the dough can immediately be developed using the plant mixer. The machine also has to be ergonomically designed so that it can easily be manually operated.
- **Manufacture:** In order to contain the cost of this machine, it has to be built of standard off-the-shelf components.
- **Maintenance:** This is sadly one of the areas most often overlooked by designers and many a maintenance engineer has, as a result, developed double-jointed dexterity! The maintenance of the machine should be optimised both in down-time and in ease of access.
- **Safety:** It goes without saying that the machine should be effectively guarded with sufficient fail-safe protection mechanisms that under no circumstances will it cause any injury to an operator or maintenance engineer.

As can be seen in the table below, I have included a last column that describes where each of the requirements will be addressed. The process design stage has already been addressed in the previous three chapters, including examples of operator instructions. The Safety design check is discussed in Chapter 14 where both a HAZOP and HACCP analysis are detailed. The rest of this chapter will focus on the actual machine design.

CUSTOMER REQUIREMENTS			DESIGN REQUIREMENT	
CUSTOMER REQUIREMENTS	Functional Performance	product	mix product in under 9 minutes hygienic design	Process design HACCP
		interface with existing plant equipment	use existing power and compressed air supplies use existing Diosna mixing bowls cycle time must designed for a 5000 loaves a day bakery	Machine design Machine design Process design
		structural integrity	no whip no noise no vibration	Machine design Machine design Machine design
	Spatial constraints	operation	ergonomic design - manually operated fit into process flow of plant bakery must be able to wheel mixing bowl into and out of mixer	Machine design Process design Machine design
		footprint	fit within plant bakery mixing hall auxiliary equipment must fit within plant bakery site	Process design Process design
	Operation		quick change over easy to start and stop clear instructions fail safe design	Machine design Machine design Operating manual HAZOP
	Manufacture	cost	off-the-shelf standard parts	Machine design
		assembly	easy fit of standard parts	Machine design
			hygienic design clear instructions	Machine design Operating manual
	Maintenance		easy to maintain quick release mechanisms to access shaft jigs to support maintenance activity clear instructions	Machine design Machine design Process design Operating manual
	Safety		fail safe design comply with legal requirements for safe operation	HAZOP OHS&A

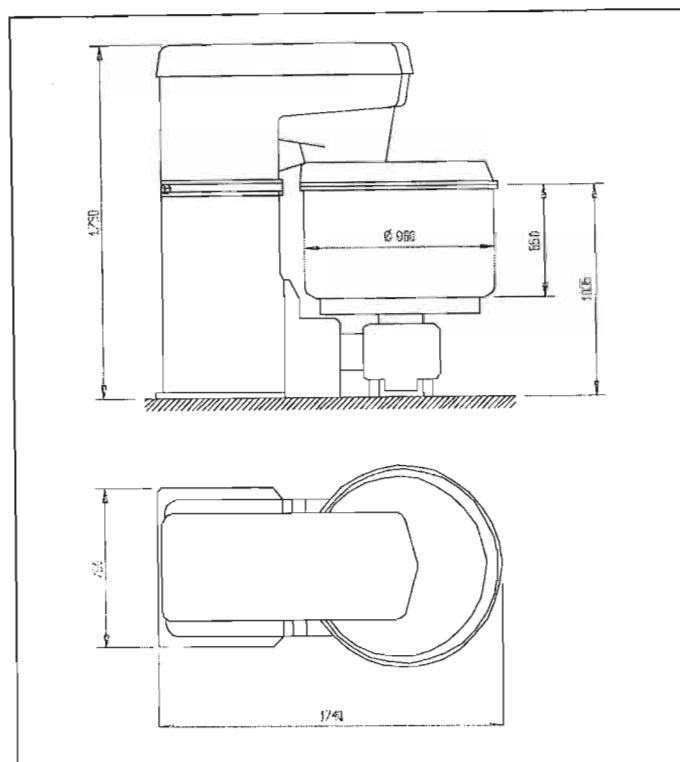
Table: Customer requirements

11.2. ANALYSIS OF PLANT MIXER

The standard mixer observed in many plant bakeries is manufactured by Diosna. A drawing of the standard spiral dough mixing machine is included below.

The machines are easy to operate with a single start button that initiates a pre-programmed mix sequence. There is an "anti-rotation" facility that unwinds the dough off the spiral allowing the straightforward release of the bowl.

The bowl is made of 316 food grade stainless steel and the rest of the body parts are finished with impact resistant synthetic enamel.



Drawing: Diosna Mixer

This is the SP240a model which allows the bowl to be removed and wheeled to a decanting mechanism. The motor output on 1st and 2nd speed is 5.5kw and 11kw respectively¹, and the footprint of the machine is 1740 mm x 790 mm.

11.3. WET-MILL CUTTER BLADE DESIGN

The design starts with the blades and then moves on to the shaft and the rest of the machine. The design of blades required finite element modelling which, for clarity's sake, has been extracted and isolated in the next chapter.

An industrial wet-mill cutter has a number of design elements, these being the intricate design of the blade-set (which had to be optimised), the drive mechanism (motor and pulleys) and the scaled shaft (bearings and lubrication). The wet-mill cutter then needed to be placed in-situ and designed for operation in a plant bakery environment. This necessitated the design of a support structure, lifting mechanism and safety devices.

¹ Diosna product sheet "spiral kneader – Diosna spiral kneading technique" 3/07/2002

11.3.1. Blade Stack Height for Industrial Wet-Mill Cutter

For the development of the industrial vertical wet-mill, the blade stack height is required. This height will determine the number of blades. From Chapter 8 section 2.3, it was determined that the ratio of the height of the dough to the blade stack height was approximately 2.

From the specification of the Diosna Spiral Kneader size SP 240a, the bowl diameter is given as 960mm and the bowl height as 550mm. This machine has a dough capacity of 240kg and a bowl capacity of 355litres. The dough height in the bowl is thus 490mm, giving a blade stack height of 245mm.

For smooth operation, the blades must be used in sets of 6, rotated at 60 degrees to one another, assuming a blade thickness of 3mm, a washer thickness of 6,5mm and a minimum clearance at the bottom of the bowl of 16mm.

If we assume there are 4 sets of blades, then:

$$245 - \{(6,5 \times 23) + (3 \times 24) + 16\} = 237,5 \text{ mm}$$

Which is 7,5mm short of the ideal height, but acceptable.

11.3.2. Motor Size

The prototype vertical wet-mill processed 50kg of dough and, from the amperage drawn, absorbed approximately 2kW of power. Scaling for the industrial machine, an increase to 240kg would require 4,8 times the power or 9,6kW. The nearest standard motor size is 11kW. As the motor will be operating in a powder environment, it needs to be rated class1 div 1 as per the South African hazardous installation regulation.

11.3.3. Blade Loading

The prototype wet-mill used one set of 6 blades, but at any one time only 4 blades were fully loaded (see diagram of product flow in section 7.2.2). Therefore, assuming a motor overload torque of 2.8, the torque absorbed per blade is given by:

$$M_t = \frac{60W}{2\pi n} = \frac{60 \times 2000 \times 2,8}{2 \times \pi \times 1440} = \frac{37,25}{4} = 9,3Nm \text{ per blade}$$

The effective force F acting at radius R=90mm on a blade is given by:

$$F = \frac{M_t}{R} = \frac{9,3}{0,09} = 103N \text{ per blade}$$

This load was used in the stress analysis of the prototype blade.

For an industrial machine with 24 blades, we again assume that 4 blades from each set of 6 are fully loaded and the motor over load torque of 2.8. Then:

$$M_t = \frac{60 \times 9600 \times 2,8}{2 \times \pi \times 1440} = \frac{178,25}{16} = 11,14Nm \text{ per blade}$$

As this is greater than the prototype blade, the industrial blade should be 1.2 times longer or equal to 148mm, say 150mm, as can be seen in the drawing of the new blade below.

The effective force F acting at a radius of 100mm on the industrial blade is given by:

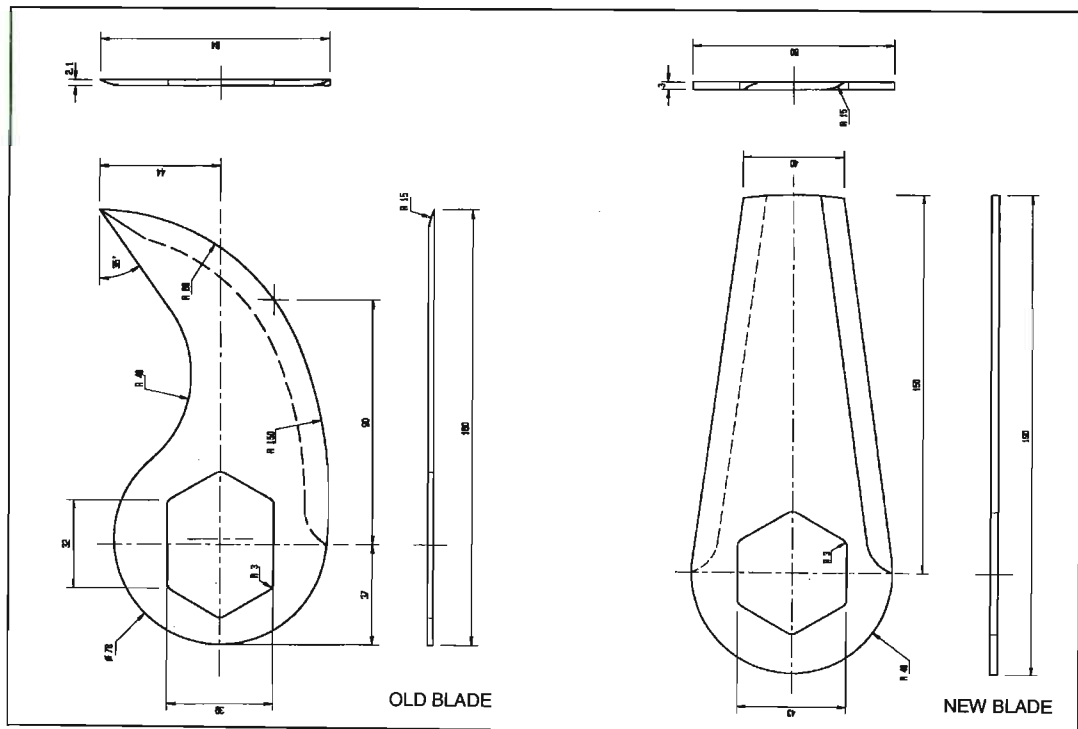
$$F = \frac{11,14}{0,1} = 111,5N \text{ per blade}$$

This load was used in the stress analysis of the industrial blade.

11.3.4. Blade Design

As we had access to the blades of the 20l bowl cutter, we were able to model the loading on them, and thus calculate the stress that they normally operate under. This was then interpreted as an industrially accepted stress load of a food-industry machine. The scaled machine blades would thus optimally be designed to operate at a similar stress. The reasoning for this is that to go below this stress threshold is an under optimised design and to go over invites the risk of future liability lawsuits (it may be difficult to explain why your blade operates at a significantly higher stress than commonly accepted). The blade loading of 111.5N (from previous section) was used and the industrially accepted stress was calculated as 30MPa. This analysis is described in detail in Chapter 12.

There were two aspects of the blade form factor that needed analysing: the shape and the cutting edge.



Drawing: Old versus new blade design

As can be seen above, the 20l bowl cutter blade was shaped with the complex curve of a sabre. Although this makes sense in the food industry (the slashing motion of the blade enables it to cut through the bone rather than get stuck on it), there is no need of

this functionality when cutting wheat. A straight edge would adequately function to rupture the grain.

Straight edged blades have other advantages:

- They are much easier to sharpen. As they have the same edge, a standard jig can be used.
- They are symmetrical and, with the standardised jig sharpening the blades, the blade set will be automatically balanced. This not only minimises vibration but it eliminates the need to rebalance the cutter head after each sharpening.
- The straight edge makes it much easier to create shorter blades to match curvature of bowl.

There are two options for the cutting edge: a convex or a concave curvature. A concave curvature is used in machining tools where there is a need to roll the metal shavings. This is a disaster as it would feed the wheat back to front of blade and thus into the dead zone. A convex curve acts as the leading edge of a wing and throws the grain up into the path of the next blade. This is obviously exactly what is desired!

Vibration management of the blade stack is very important. We have already spoken about balancing, which is the most important variable in managing dynamic motion. There is also a need to build in some dampening of the blade flutter. The blade acts as an aerofoil and flutters while rotating on the mandrill at speed. The washers that lie between each blade were thus used to dampen this flutter. Teflon was the material selected for the washers, as it is soft enough to absorb vibration, but hard enough not to be crushed when the blade stack is tightened.

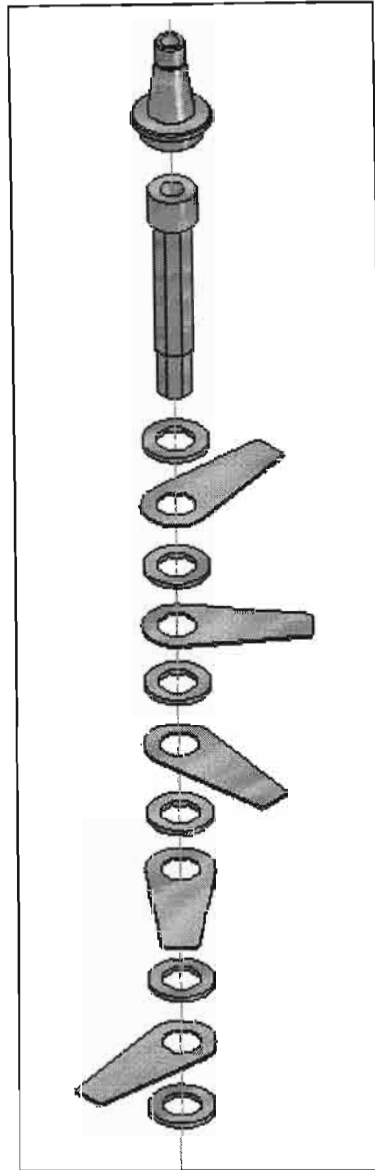
Once the form factor was decided upon, it had to be checked to see if the stress was acceptable. This analysis can be seen in Chapter 12

As can be see from the calculation, the redesigned large blade is within the acceptable stress tolerance at 50.7 MPa at 2800 rpm.

The blade was then further optimised and its working life doubled by having a cutting edge run on both sides of the blade.

In the interests of safety, the blades should be stamped with their relative position on the shaft.

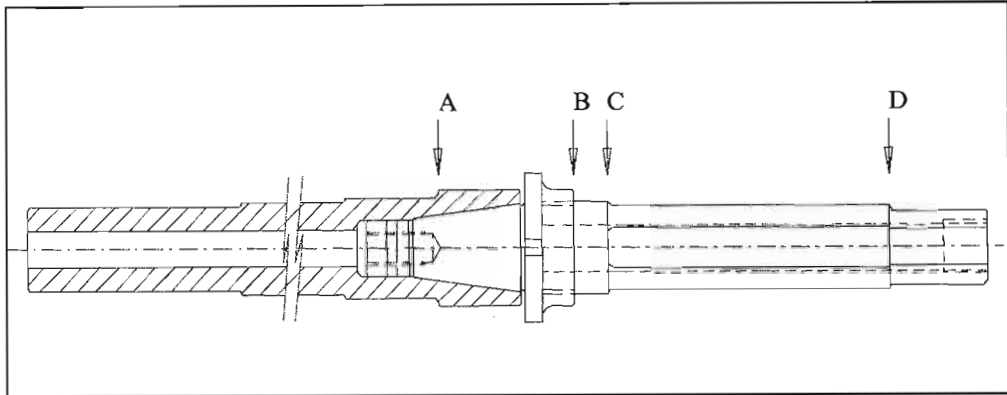
A three dimensional, exploded drawing of the final blade set design can be seen below:



Drawing: Final Blade Stack Design

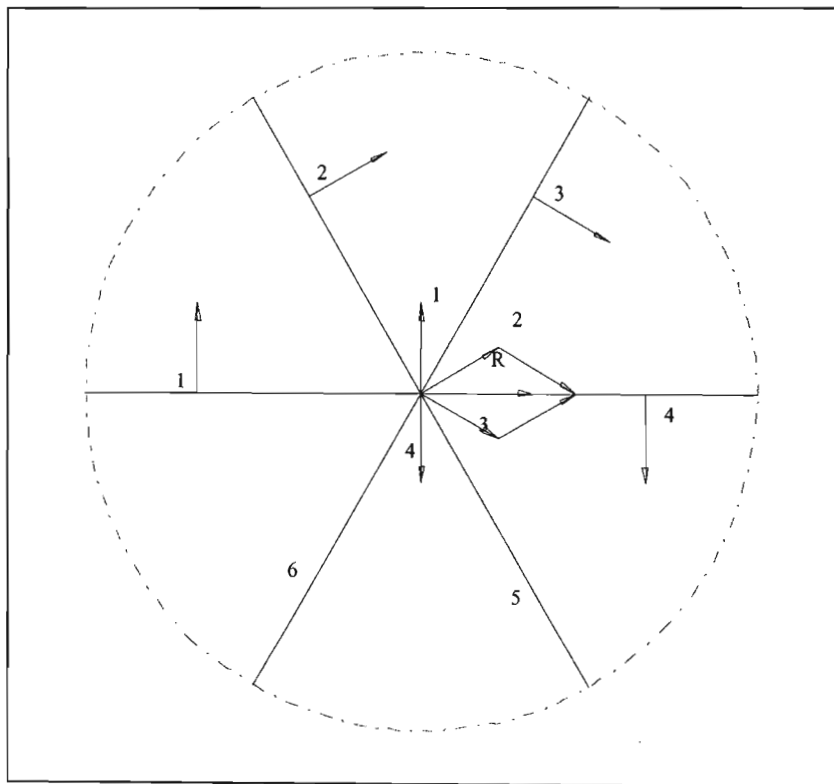
11.4. WET-MILL CUTTER MANDRILL AND BEARINGS DESIGN

The design of the cutter mandrill is based on the dimensions obtained from the blade stack height calculations and the proportions of standard blades used in industry. The stress analysis of standard blades indicates that the maximum stress in the blade is approximately 35MPa. This stress will be used as the defacto stress for the shaft and mandrill design.



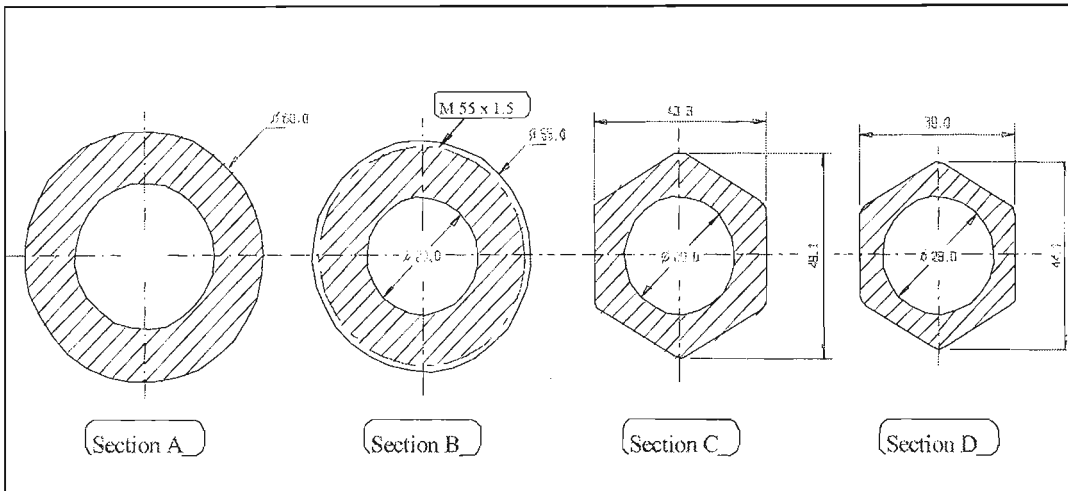
Drawing: Critical sections of cutter mandrill and shaft

The action of the blades while the milling operation is in progress is illustrated in the drawing below. This action produces a bending moment on the shaft and mandrill.



Drawing: Blade loading and resultant force on mandrill

From the preliminary drawing of the shaft and mandrill assembly, four main areas of high stress are identified. The cross section of these sections and dimensions are given in the figure below.



Drawing: Cross section of critical shaft and mandrill

A bending moment diagram for the shaft and mandrill under the action of the applied forces was constructed. From these values an analysis of each critical section was performed, the results of the stress calculations are tabulated in the figure below.

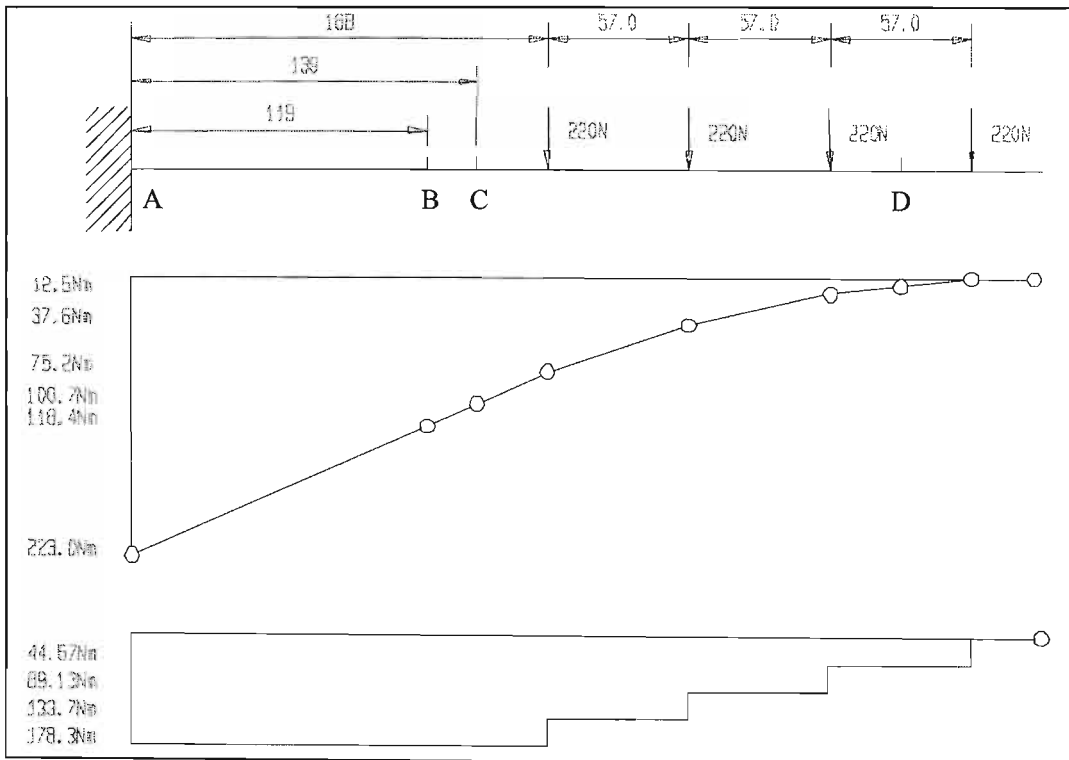


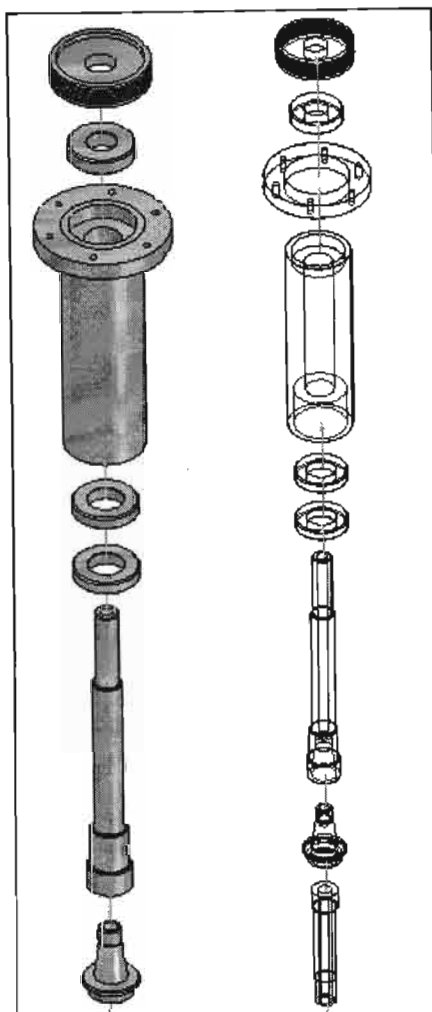
Figure: Bending moment diagram of cutter mandrill and shaft

Property at shaft position:	A	B	C	D
Area mm ²	1865	1760	1005	697
Inertia I mm ⁴	526078	328736	181092	108865
Inertia I _p mm ⁴	1052157	657472	362184	217730
Moment Nm	223.0	118.4	100.7	6.25
Torque Nm	178.3	178.3	178.3	44.7
y mm	30	26	21.6	19.5
r mm	30	26	24.5	22
K _f	1.65	3	1.6	1.5
K _{fs}	1.3	2.2	1.2	1.2
σ _b MPa	21	28	19.2	1.68
τ MPa	6.6	15.5	14.5	5.4
σ _e MPa	24	38.8	31.6	9.5
S _a MPa	21.3	28.9	19.8	1.67

Table: Summary of stress calculations

An example of a sample detailed calculation is given in Appendix G

The exploded view of the final mandrill design can be seen below.



Drawing: Final mandrill design

11.5. WET-MILLER CUTTER PULLEY AND BELT DESIGN

The choice of a suitable drive between the 11kW, 3 phase, 380 volt electric motor and the shaft spindle of the wet-mill depend on a number of factors such as the speed, velocity ratio, centre distance, power transmitted, maintenance and cost. The nature of a bakery would by necessity require a low maintenance flexible transmission system and not a gear or chain drive. Since a flanged motor running at 1440 r/min has been selected and a fixed centre distance with a 1:1 velocity ratio, the selection of a suitable belt drive to meet the above requirements may be determined if the centre distance is known.

Preliminary drawings of the wet-mill and recommended centre distances for belt catalogues suggest that a suitable centre distance would be approximately 750mm

and belt length of 2000mm with 160mm diameter pulleys for the standard wedge belt. Other types of belt drives will also be considered in order to select the most efficient and maintenance free drive.

11.5.1. Selection Procedure

The following factors should be carefully considered during drive selection:

- Trip rate on low ratio drives should not exceed 8 trips/second.

$$\text{Trip rate} = \frac{0.0524 \times \text{pulley p.d in mm} \times r / \text{min of shaft}}{\text{length of belt in mm}}$$

- For 1:1 drives it is recommended that pulley diameters be above the minimum required for the belt sections used.

11.5.2. Service Factor

For soft start electric motor an applicable service factor for class 2 medium duty application would be 1.2 for over 10 hours duty per day.

11.5.3. Design Power

Multiply the normal running power required by the service factor. This gives a design power of 13.2kW, which is used as the basis for the selection of the drive.

11.5.4. Belt Selection

From belt power transmission tables the following values are found for the various belt types:

Belt Type	Specification	Pulley Dia.	Power / Belt	No. of Belts
B section V-belt	B1950	150mm	3.29kW	4
A section Wedge belt	13N SPA	160mm	6.78kW	2
Poly-V belt	8PK1980	160mm	14.1kW	1 x 8 ribs
Toothed belt	700H	105mm	15.9kW	1 x 76mm

Table: Belt types and power requirement

Type	Drive Cost	Centre Distance	Tension	Adjustment
B section V-belt	R575.41	739mm	668.5N	38mm
A section Wedge belt	R624.10	749mm	571.7N	35mm
Poly-V belt	R706.92	739mm	550.7N	14mm
Toothed belt	R1336.74	686mm	512.3N	18mm

Table: Belt cost and loading

The poly-V belt was chosen for the wet-mill drive since it had the smallest adjustment dimension, and one of the lowest span tensions. It was relatively cost effective requiring less maintenance and longer belt life than the other belts considered. Other forms of drives, for example gears and chains, were not considered as they are not

suitable for long centre distances and noise. These drives also require lubrication and are not generally used in the food industry. (Food grade grease is available but can still taint an edible product.)

11.6. FATIGUE ANALYSIS

Components which are subjected to repeated load cycling often fail by fatigue. These typical fatigue fractures do not involve macroscopic plastic deformation and usually occur after many thousands of cycles. On the sub-microscopic level however, plastic deformation (or slip) must take place for eventual fatigue failure to take place. When a sub-microscopic slip occurs one of two things may occur. If the slip is slight and if the material has sufficient strain-hardening or precipitation-hardening properties, then the point of local plastic deformation may become strengthened enough to stop the slip before a crack is initiated. If this is not the case, the highly localised region subjected to slip cycling usually develops sub-microscopic cracks. These sub-microscopic cracks grow and join together to form one or more macroscopic cracks, which continue to propagate until the cross-section is sufficiently reduced, allowing complete fracture to occur with one final applied load.

11.6.1. Factors that affect the S-N curve

Load factor C_l

When a component is not subjected to rotating bending as in the standard fatigue test, it is normal to apply a load correction factor to correct for the type of load condition. In the case of the wet-mill mandrill, which is subjected to bending and torsional loads simultaneously, an equivalent bending stress is found which relates to the standard laboratory test for which the load factor $C_l = 1$.

Size factor C_d

Large components, subjected to bending stresses, show reduced fatigue strength when compared to the standard test specimen. This is mainly due to the decrease in the stress gradient as the diameter increases. The wet-mill mandrill shaft is of hollow cross-section, requiring an equivalent diameter to determine the size factor $C_d = 0.86$

Surface factor C_s

Most fatigue failures nucleate on or near the surface of components where the surface stresses are usually the highest, especially in reversed bending. Hence the surface finish becomes an important factor in influencing the fatigue life. The wet-mill mandrill shaft will be subjected to repeated changes of cutter blades during normal daily maintenance. The surface will therefore soon show signs of surface irregularities: for this reason the surface factor $C_s = 0.75$

Material factor C_m

Fine grained materials exhibit fatigue properties that are superior to the fatigue properties of coarse grain materials of the same composition. For austenitic steels and many nonferrous alloys, the degradation of fatigue strength with large grain size becomes significant. Grain flow direction in rolled components relative to the direction of loading also has a significant effect on the fatigue strength. The grain direction in the wet-mill mandrill shaft is in the longitudinal direction in the plane of bending which is beneficial. The material factor for the wet-mill mandrill shaft will be taken as $C_m = 0.8$.

Reliability Factor C_r

Published values of fatigue data are mean values, giving components a reliability of 50%. For higher reliability of say 99% a factor $C_r = 0.814$ is used.

The corrected fatigue limit, S_n @ 10^6 cycles, for the wet-mill mandrill is then given by the equation:

$$S_n = \frac{1}{2} S_u \cdot C_l \cdot C_d \cdot C_s \cdot C_m \cdot C_r \quad (1)$$

Using the above factors the fatigue limit of the cutter mandrill is:

$$\begin{aligned} S_n &= \frac{1}{2} S_u \cdot C_l \cdot C_d \cdot C_s \cdot C_m \cdot C_r \\ S_n &= \frac{1}{2} \times 500 \times 1 \times 0.86 \times 0.75 \times 0.8 \times 0.814 \\ S_n &= 105 \text{MPa} \end{aligned}$$

11.6.2. Fatigue Design Considerations

The fatigue life predictions of notched components such as the wet-mill cutter mandrill which are subjected to a combination of mean and alternating stress are based on one of two methods, either the *Nominal Mean Stress* method or the *Residual Stress* method. For components subjected to more than 10^6 cycles load cycles or infinite life, the design is usually based on the Residual Stress method which is defined as:

All stresses (both mean and alternating) are multiplied by the fatigue stress concentration factor K_f or K_{fs} , and correction is made for yield or residual stress if the calculated values exceed the material yield stress. The fatigue stress concentration factors are given in the summary table of section 11.4.

At cross section B, the fluctuating stress S_a was calculated as 29 MPa.

The fatigue limit for this component, as calculated above, is 105 MPa.

Therefore the reserve factor (R_f):

$$R_f = \frac{S_n}{S_a} = \frac{105}{29} = 3.6$$

This is satisfactory as design overload conditions have been considered.

11.7. DEFLECTION AND VIBRATION ANALYSIS

The cutter mandrill may be considered as a rotating stepped cantilever beam built in at A, with changes in the cross section occurring at B, C, & D. The position of the applied loads is given as 1, 2, 3, & 4 in the diagram below.

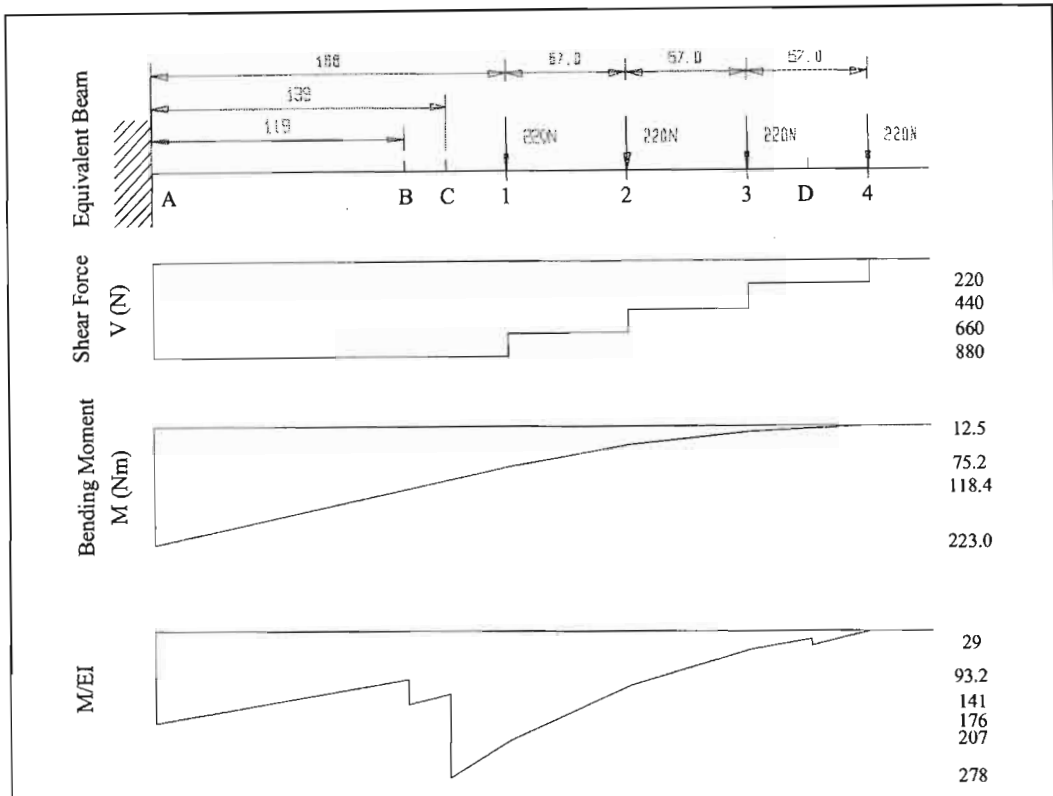


Figure: Bending moment and M/EI diagram

As a first estimate, the deflection at the free end may be found by approximating the stepped cutter mandrill as a beam of equivalent uniform diameter, subjected to the forces shown. By using the principle of superposition, which states that, when one or more loads are applied to a beam of uniform cross section, the maximum deflection at the free end of the beam is the sum of the individual deflection produced by the loads acting singly.

Assume that the cutter mandrill has a uniform diameter of 55mm, then from tables for cantilever beam with point loads the deflection at the free end is given as:

$$y = \frac{PL^3}{3EI}$$

(PTO)

Where:

$$I = \frac{\pi}{64} [D^4 - d^4]$$

$$I = \frac{\pi}{64} [55^4 - 28^4] = 420\,000 \text{ mm}^4$$

Then determining the deflection at the free end (y) for each load yields:

$$y_1 = 0.00414 \text{ mm}$$

$$y_2 = 0.00994 \text{ mm}$$

$$y_3 = 0.01958 \text{ mm}$$

$$y_4 = 0.03398 \text{ mm}$$

$$y_{total} = 0.068 \text{ mm}$$

This is a very small deflection, but to be comprehensive the deflection is checked below using a more accurate method.

The deflection of the free end of the cutter mandrill shaft is now determined using the moment area method. This method is suitable for a stepped shaft where the deflection of only one point is required.

Assumptions:

- The slope at the bearing at A is zero.
- The modulus of elasticity $E=200\text{GPa}$
- The shear force and bending moment diagrams are as shown.
- The shaft from A to B can be approximated as a solid 60mm diameter section.

Section	Dimension (mm)	Inertia (mm ⁴)	EI X 10 ¹⁰	Moment Nm
A → B	60	636172	12.7	223
B → C	55	419008	8.38	118
C → D	44	181092	3.62	101
D → end	39	108865	2.18	6.3

Table: Section properties to calculate deflection

The deflection is now calculated for each section of the curve. The table below summarises the calculations. The area has been split into simple geometries for which the distance of the centroid from the end of shaft was easily calculated.

Section	M/EI x 10 ⁴ (-8)/mm	Area (mm ²)		Distance (mm)		Deflection (mm)		Section Deflection (mm)
		Rectangle	Triangle	Rectangle	Triangle	Rectangle	Triangle	
A ? B	176	11091	4927	279	299	0.030943	0.014732	0.045675
B ? C	141.2	2400	210	210	213	0.005040	0.000415	0.005455
C ? 1	278	6003	1145	185	190	0.011106	0.002176	0.013281
1 ? 2	104	6099	2935	141	152	0.008600	0.004461	0.013061
2 ? 3	35	1995	1966	85	95	0.001696	0.001868	0.003563
3 ? D	17	980	966	43	47	0.000421	0.000454	0.000875
D ? 4	29	476	168	28	18	0.000133	0.000047	0.000180
Total								0.082091

Table: Deflection due to bending stress

From the table above, the total deflection of the shaft is calculated as 0.08mm.

The torsional deflection may be similarly calculated using the following equation:

$$\sigma = \sum \frac{M_i L_i}{J_i G}$$

Where: M_i is the applied torque.

L is the section length.

J is the section polar moment of inertia.

G is the torsional modulus = 80 GPa.

The table below summarises the calculations. The section reference is from the mandrill drawing above.

Section	Length (mm)	Torque (Nm)	Inertia (mm ⁴)	Deflection (rad)
1	119	178.3	1052157	0.00025
2	20	133.7	657472	0.00005
3	131	89.2	362184	0.00053
4	28.5	44.67	217730	0.00007
Total:				0.00090

Table: Deflection due to torsional stress

From the table above, the total torsional deflection (angle of twist) of the shaft is calculated as 0.009 rad.

11.7.1. Shaft Vibration and Critical Speed

Because of imperfections in the manufacture and assembly of the cutter mandrill, as well as the deflection caused by the applied force, the centre of mass will not coincide exactly with the centre of rotation of the system. Consequently the rotating centrifugal force on the eccentric mass centre will increase, causing the whirling eccentricity to also increase, producing an even higher rotating centrifugal force. If the actual rotating shaft speed approaches any critical speed of the system, a violent bending mode vibration may result.

The critical speed of the shaft is calculated using Raleigh's Energy Method:

$$n_c = \frac{30}{\pi} \sqrt{\frac{g \sum w\delta}{\sum w\delta^2}}$$

Where: W is 13.35N at each load node.

g is acceleration due to gravity acting on six 225g blades.

δ is the deflection from the M/EI diagram above.

$$\sum w\delta = 25.75 \times 10^{-4}$$

$$\sum w\delta^2 = 15 \times 10^{-8}$$

(PTO)

Thus, $n_c = 3920$ rpm, undamped. This exceeds the design speed, of 1440 rpm, by over 270 %.

This is the worst case scenario where the blade is running with no load, which should never happen. The machine should only be run when there is dough inside the bowl. In other words, there is no risk of ever reaching the dangerous critical speed.

11.8. HYGIENIC DESIGN

As this machine is operating in a food environment, it will need to comply with food regulations with respect to construction. Some standard design 'good practice' design features are depicted in the pictures below. It must be noted that in all food environments there must be no square corners, and the minimum radius should be 3mm¹.

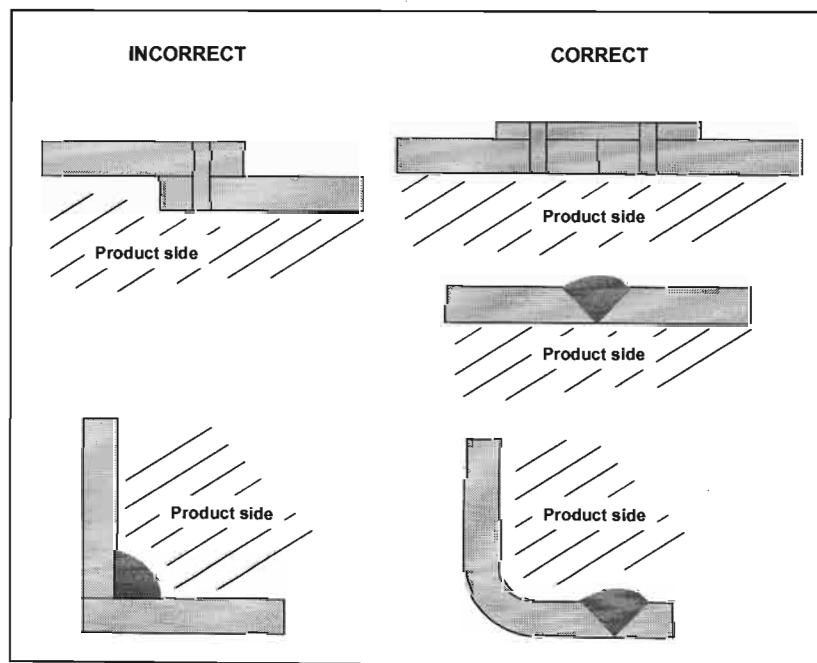


Figure: Hygienic design examples

¹ Standard FMCG hygienic mechanical design criteria

11.9. WET-MILL CUTTER MATERIAL SPECIFICATION

The following materials could be used in the manufacture of the wet-mill:

11.9.1. Cutter Blades

Material Standard: En X90CrMoV18

ASTM 440B

Bohler N 685

Martensitic Cr-steel with Mo and V added to give high hardness and wear resistance with excellent corrosion resistance. Used in the food industry and for medical instruments for cutting tools of all descriptions due to the superior corrosion resistance with hardness and toughness.

Mechanical Properties			
Tensile Strength	Proof Stress	Brinell hardness	Ductility
900 MPa	700 MPa	680	12 %

Table: Mechanical Properties of ASTM 440B

Chemical Composition %					
C	Si	Mn	Cr	Mo	V
0.9	0.45	0.4	17.5	1.1	0.1

Table: Chemical Composition of ASTM 440B

11.9.2. Drive Shaft

Material Standard: En X39CrMo17.1

Bohler N 557

Martensitic Cr-steel with C added to allow hardening and tempering to give higher strength. The high chromium and molybdenum content give good resistance to organic and nitric acids, and sea water. It has excellent wear resistance and good anti-frictional properties. It is impervious to crevice corrosion cracking.

Mechanical Properties			
Tensile Strength	Proof Stress	Brinell hardness	Ductility
750 MPa	550 MPa	600	15 %

Table: Mechanical Properties of En X39CrMo17.1

Chemical Composition %					
C	Si	Mn	Cr	Mo	Ni
0.45	0.4	0.65	16.4	1.1	0.1

Table: Chemical composition of En X39CrMo17.1

11.9.3. Cutter Blade Mandrill

Material Standard: En X2CrNiMo17-12-2

ASTM 316L

Bohler A200

Stainless austenitic Cr-Ni-MO-steel with low C content which assists resistant to intergranular corrosion in the temperature range up to 400°C. Excellent resistance to

acid attack having a reducing effect. Also resistant to other media which cause pitting, crevice and stress corrosion cracking.

Mechanical Properties			
Tensile Strength	Proof Stress	Brinell hardness	Ductility
500 MPa	200 MPa	215	40 %

Table: Mechanical Properties of ASTM 316L

Chemical Composition %					
C	Si	Mn	Cr	Mo	Ni
0.03	0.5	1.4	17	2.2	11.5

Table: Chemical Composition of ASTM 316L

11.9.4. Other Structural Components of Wet-Mill

Material Standard: En X2CrNi19-11

ASTM 304L

Bohler A600

Low carbon, austenitic Cr-Ni-steel which resists intergranular corrosion in the temperature range up to 350°C. The stainless steel resists weathering and the action of steam, water and acids as well as alkaline solutions.

Mechanical Properties			
Tensile Strength	Proof Stress	Brinell hardness	Ductility
500 MPa	190 MPa	215	45 %

Table: Mechanical Properties of ASTM 304L

Chemical Composition %					
C	Si	Mn	Cr	Mo	Ni
0.03	0.5	1.4	18.5	0	10.5

Table: Chemical Composition of ASTM 304L

11.10. FINAL DESIGN

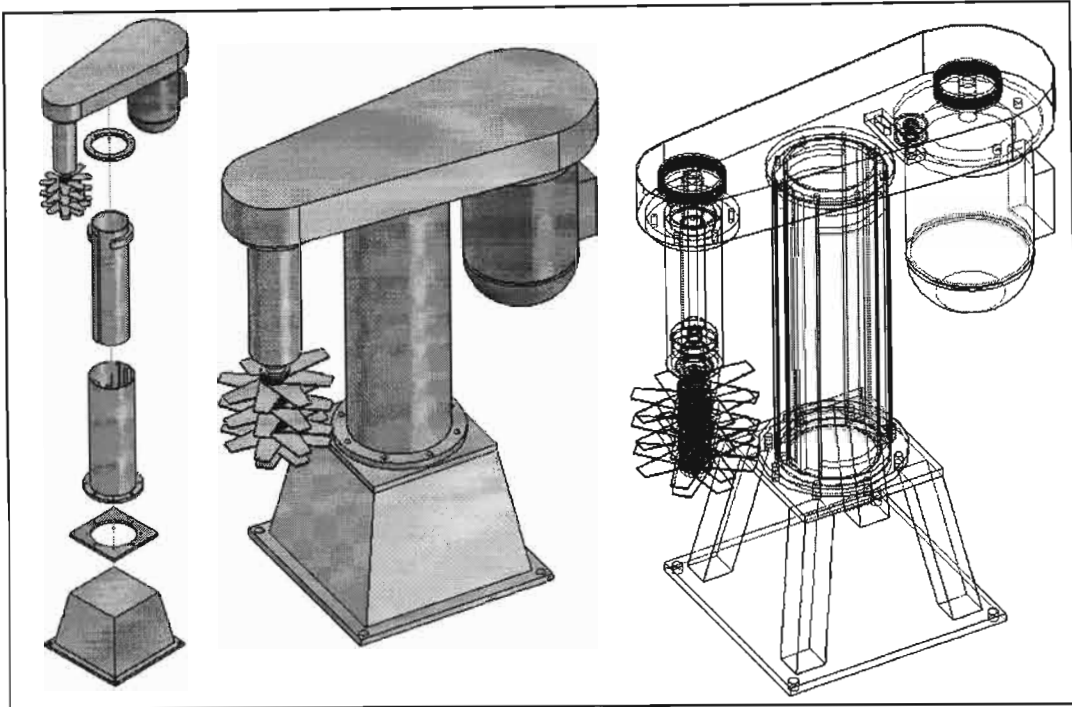
The rest of the machine is made from standard components and materials. The frame is designed to be fabricated from standard sized plate and hollow tube in any standard machine shop. Full fabrication drawings have been completed – and are available on request.

The pneumatic cylinder was selected to run off a 5 bar supply (standard compressed air supply in a plant bakery). It is inserted through the centre inner tube and has the capacity to lift 500kg 600mm, high enough to enable the Diosna mixing bowl to be removed.

All parts are food grade steel with corrosion properties that allow them to be steam spray cleaned.

The stand is tapered to allow sufficient space for the Diosna mixer to fit.

The final assembly is shown below. A full set of fabrication drawings have been completed for the machine, some example parts are included in appendix H.



Drawing: Final vertical wet-mill cutter assembly

11.11. WET-MILL CUTTER MAINTENANCE

The wet-mill cutter has been designed with the maintenance engineer in mind:

The cutter head is easily removed, and once the taper lock has been knocked off the shaft slides straight out. It is expected that the maintenance engineer will have a set of 2 mandrills together with a jig that will be used to transport them and support them while they are being worked on. It is envisioned that the engineer will approach the machine pushing a jig that has two mandrill supports, one of which is holding the overhauled mandrill. The engineer simply drops the mandrill in the wet-mill cutter into the empty slot on the jig and lifts the ready one in the jig to replace the one just removed. It is expected that, in this way, the turnaround time for a mandrill changeover should be less than 2 minutes.

The dimensions of the wet-mill cutter are within the ergonomic recommendations specified by Ullman¹. Thus all parts of the machine are within easy reach of both the operator and the maintenance engineer.

¹ David G Ullman, The mechanical design Process, 1992, Chapter 4 pg 57

11.11.1. Life of Wearing Parts

The primary wearing parts of the machine are the blades. It is envisioned that the blades will be sharpened once a day. This should be done by exchanging the mandrill with one that has been prepped, allowing the workshop to schedule the sharpening during the day. The sharpening should take under 1 hour and it is expected that a jig will be used as described in the section on blade design. Because the blades have a double cutting edge it is possible that they are simply rotated on the first day and then both sides sharpened on the second day.

The only other wearing parts of the machine are the belts, bearings and lubricant. The selected bearing (6309) has a life of 92000 hours. The belt is expected to last about 5 years. This is an estimate, as belt life can vary enormously depending on how it has been treated. For instance, one jam resulting in a belt skid will halve the life of a belt. The lubricant has a life of 5800 hours: to be safe it should be placed on a monthly maintenance schedule. The belt and bearings can either be checked using a preventative maintenance programme (mostly using vibration analysis) and replaced when necessary, or a simple time logging unit can be attached to the power supply to the machine to log hours of operation. At 85% of recommended life, the wearing parts should be checked and if in order, allowed to run to 100% recommended life.

11.12. WET-MILL CUTTER SAFETY

The wet-mill cutter has a number of safety features.

The machine will be hard-wired with three safety switches.

- The first will be a light sensor to detect the presence of a bowl. Without a bowl in position, the machine will not start.
- The second is linked to the pneumatic cylinder. The machine will only start if the cylinder is in the down position.
- The third is that the lid on the mixer must be down. If the lid is not down, the cutter will not start.

A power isolation switch will be installed with a lock-out facility allowing for safe isolation practices to be followed during routine maintenance.

The wet-mill cutter blades are situated at the bottom of the bowl. No extra guarding was seen as necessary as the bowl is sufficiently thick to contain a broken blade. The current guarding of the bowl will ensure that the blade does not escape from the bowl.

It is of course expected that a Safe Operating Procedure (SOP) be drawn up for the wet-mill cutter in each plant in which it is installed. For instance the SOP should require that gloves be worn to remove the mandrill from the machine. It is also expected that each operator be trained on the machine, the safety procedure and the dangers of a broken blade.

11.13. DESIGN OPTIMISATION

A number of design optimisations have been followed throughout this thesis. In previous chapters we have seen the recipe optimised for cost and for functionality within a plant bakery environment. We saw the soak time optimised for softness versus time, where each extra hour of soaking significantly increased the working capital load of the plant. The wet-mill cutter concept was optimised for integration ease and minimisation of capital expenditure, the process equipment was optimised to provide continuous feed into the downstream bakery equipment and various chilling options were analysed to provide the least cost temperature management.

This chapter has two specific areas of optimisation: blades and belt; plus a third general area of optimisation: material selection. These three are described in more detail below:

11.13.1. Blade Optimisation

As already described earlier in the chapter, the blade design was iterative, driven by a process of optimising multiple design criteria. Primarily the blades had to function effectively, within a design stress specification. This step required the use of finite element modelling which is described in the following chapter. It also looked at vibration analysis and the effective dampening of Teflon washers. Secondly their useful life was to be maximised, which led to a double edge design, effectively doubling the useful life of each blade. Thirdly they had to be easy to maintain – in this case meaning easy to sharpen. Together with other design criteria this led to the step change move to the straight edge blade which can be easily sharpened with the aid of a jig.

The blade stack was designed to allow for flexibility in rotational speed. The current drive selection keeps blade tip speed similar. In the testing of the plant bakery rig, it may be advantageous to run the machine at a higher speed (either to get a finer cut or a quicker cut). The blades' stress analysis was completed at the faster 2 pole motor speed.

11.13.2. Belt & Drive Optimisation

The belt was similarly optimised for maximum life and cost. It is a standard off-the-shelf easily available component. The drive mechanism is designed to be flexible, so that, if during testing of the scaled machine it is decided to run faster, the motor can be changed to a 2 pole one, the pulley diameter changed, and the belt simply upgraded.

11.13.3. Material Optimisation

The previous section describes each machine component's material selection. It can be seen that specific material properties were sought for each part. For instance, the cutter blades needed typical tool properties of hardness and toughness. The drive shaft required high wear resistance and anti-frictional properties and the mandrill needed high corrosion resistance as it is operating in a wet enzymic environment. The rest of the machine uses standard food grade, low carbon, austenitic steel.

In this way the machine is not only cost optimised in that higher quality steel is only used where required, but it also means that the machine will last longer thus the TPM concept of 'Total life cost' is reduced.

12. STRESS ANALYSIS OF INDUSTRIAL BLADE

The purpose of this analysis was to investigate stresses and displacements of cutter blades of different designs. A MSC NASTRAN FEM modelling package was used to create a model for both designs. The drawings that the models were based on are included in appendix F and the loading conditions are as described in the previous chapter.

12.1. FINITE ELEMENT MODEL – ORIGINAL DESIGN

The model drawings are included in the appendix.

12.1.1. Conditions

The load was specified as follows (see appendix F for load drawings)

Gravitational load ($g=9.81 \text{ m/s}^2$).

Centrifugal load caused by rotation with velocity 2880 rpm (48 rps).

Point load of 100 N applied at 90 mm distance from the centre of rotation.

The nodes were constrained at the drive surface area (see appendix F for constraint drawing)

The input and model specifications are tabled below:

Type of elements	Number of nodes	Number of elements
Plate	2375	2231

Table: FEA old blade model summary

Total weight	0.110728 kg	
Material	Carbon steel	Isotropic
Stiffness	E = 200 GPa	Nu = 0.3

Table: FEA old blade input summary

12.1.2. Results

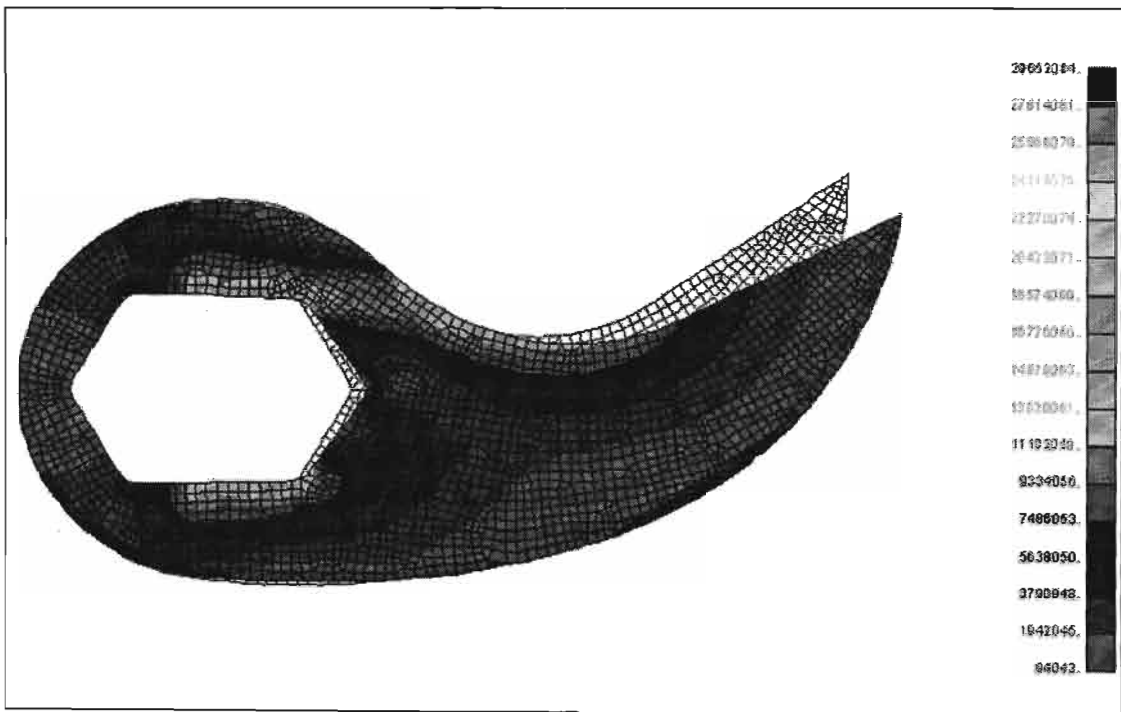
Two analyses were performed, subjected to the following loading conditions:

- Rotational velocity and gravity;
- Combined 100 N load, Rotational velocity and gravity.

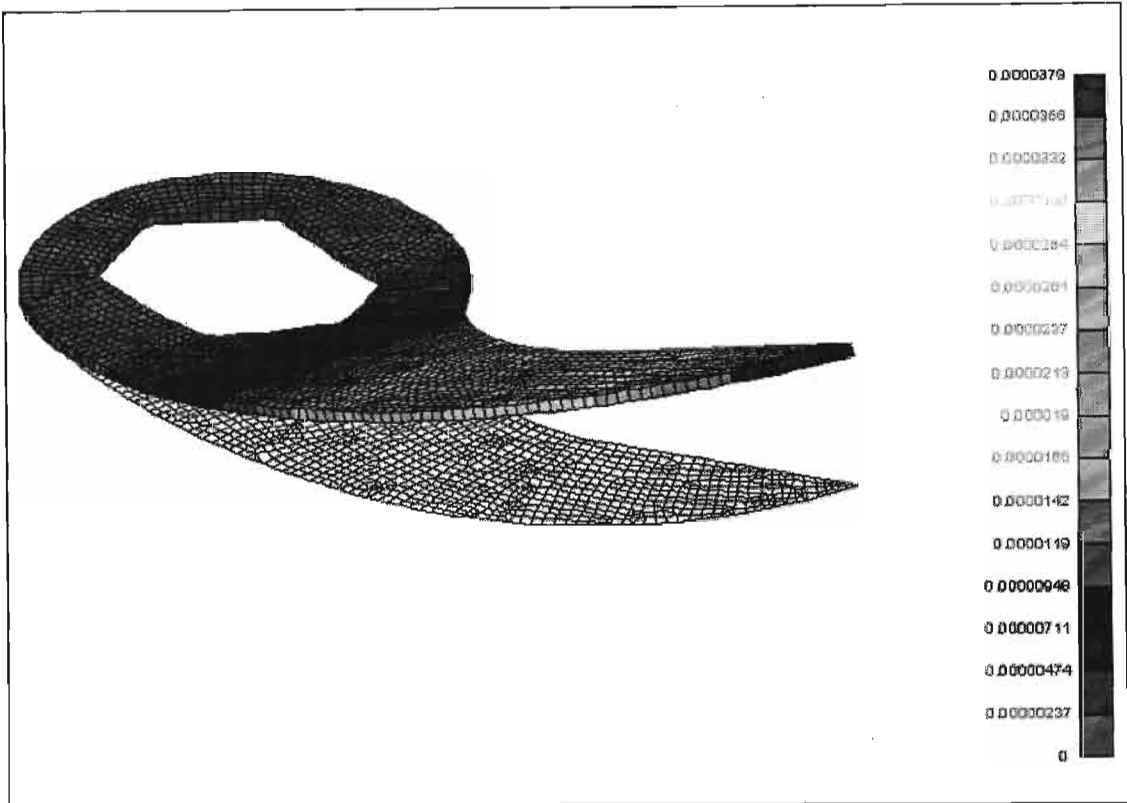
The results obtained can be seen on the figure below. The results shown are the von Mises stress at the top fibres of the plate, which is a unified stress theory. All the deformed shapes shown in the figures are exaggerated (scaled up) considerably in order to be able to see the shape of the deformation.

Maximum von Mises stress: 29.94 MPa.

Maximum displacement: 0.0361 mm.



FEA XY View: Von Mises Stress Plot, Pa (The deformed model is shown).



FEA Isometric View: Total translation, mm.

Other views of the translation model can be seen in appendix F.

12.2. FINITE ELEMENT MODEL - LARGER, SCALED DESIGN

The blade tip was experiencing unacceptable stress – even at the smaller blade size. With a larger blade this was going to be a problem – so it was necessary to redesign the blade. The new blade drawing has already been seen in Chapter 11.3.4. The finite element model that was constructed can be seen in appendix F.

12.2.1. Conditions

The new loading conditions remain unchanged except for the point load, which has moved further from the centre proportional to the larger blade:

- Gravitational load ($g=9.81 \text{ m/s}^2$).
- Centrifugal load caused by rotation with velocity 2880 rpm (48 rps).

- Point load of 127.5 N applied at 110 mm distance from the centre of rotation (Figure 3)

All loading and conditional figures and drawings are included in appendix F.

The constraints remain unchanged with respect to previous design. The nodes (as shown in figure in appendix F) are fully constrained (fixed).

Type of elements	Number of nodes	Number of elements
Plate	3190	3041

Table: FEA new blade model summaries.

Total weight of the part	0.233558 kg	
Material	Carbon steel	Isotropic
Stiffness	E = 200 GPa	Nu = 0.3

Table: FEA new blade Input summary

12.2.2. Results

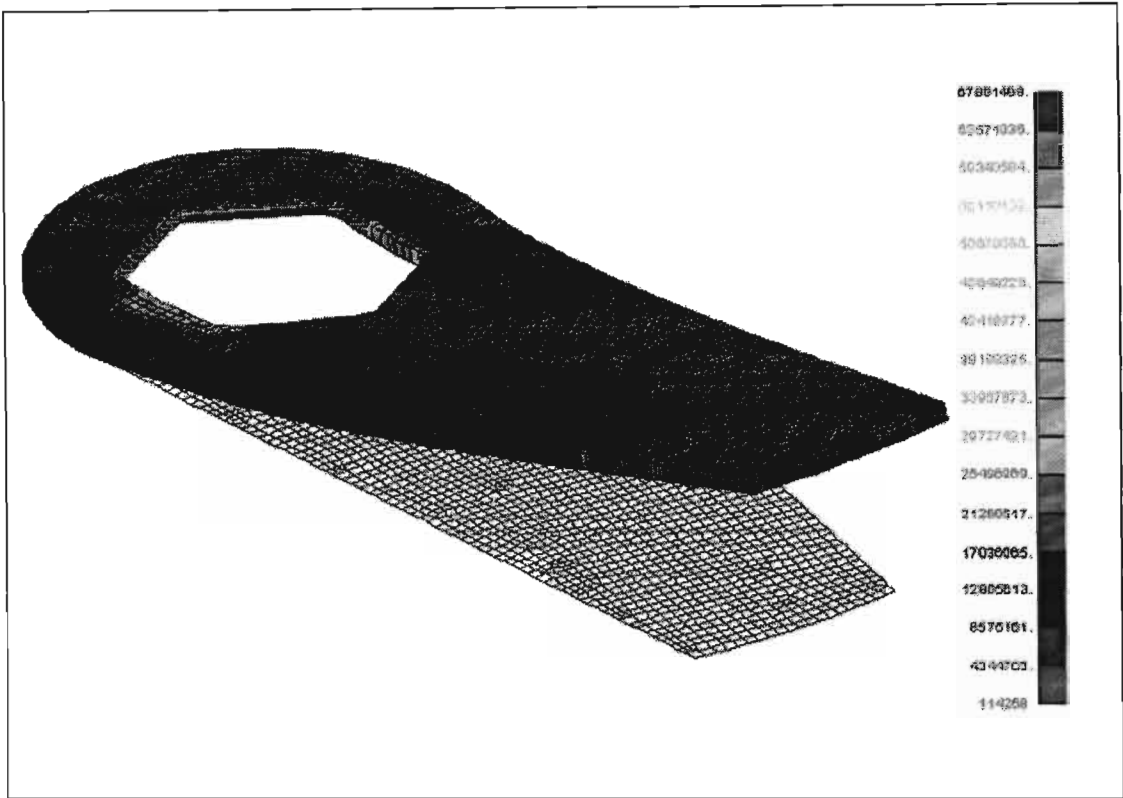
As, before, two analyses were performed, subjected to the following loading conditions:

- Rotational velocity and gravity;
- Combined 100 N load, rotational velocity and gravity.

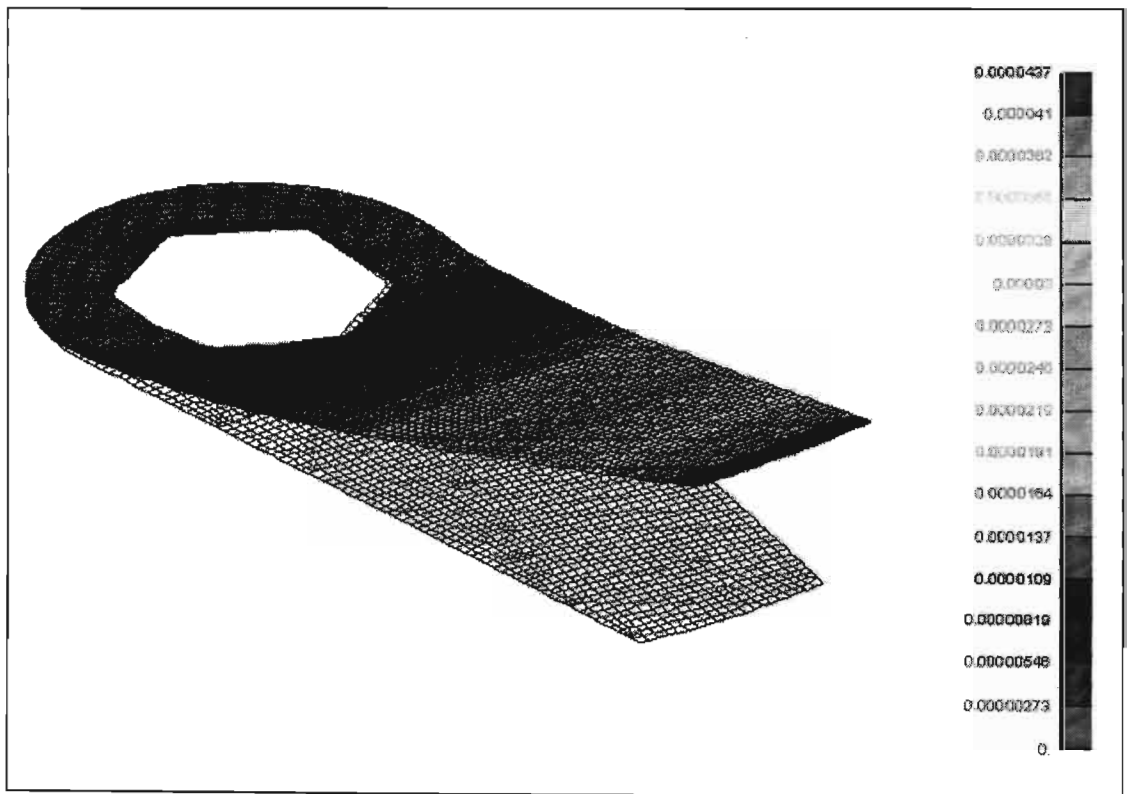
The resultant graphs are detailed below. The results shown are the von Mises stress at the top fibres of the plate, which is a unified stress theory. All the deformed shapes shown in the figures are exaggerated (scaled up) considerably in order to be able to see the shape of the deformation.

Maximum von Mises stress: 50.72 MPa.

Maximum displacement: 0.0437 mm.



FEA Isometric View: Von Mises Stress Plot, Pa (the deformed model is shown)



FEA Isometric View: Total translation, mm (The deformed model is shown).

12.2.3. Comparison

	Original design	Modified design	Increase, %
Weight, kg.	0.110728	0.233558	111
Applied load, N.	100	127.5	28
Max. VM stress, MPa.	29.94	50.72	69
Max displacement, mm.	0.0361	0.0437	21

Table: Comparative analysis of the results.

The results show the new design having an increase in stress and displacement by 69% and 21% respectively. This can be explained by the increase in total mass of the structure (by 111%) which subsequently increases centrifugal load during the rotation of the blade. The other cause would be an increased load of 28%, which acts at a longer distance, causing an increase of the bending moment at the constraint.

13. WET-MILL ECONOMICS AND INTEGRATION SCHEDULE

13.1. CAPITAL COST

The capital equipment expenditure required is outlined in the table below:

CAPEX ITEM	Best case	Worst case
Conveyor to clean wheat silo	20	50
Conveyor from silo to road loading 20 50	20	50
Dedicate flour truck (best) or pup (worst)	0	200
TOTAL PER MILL	40	300
New silo	10	15
Pneumatic venturi with piping - or	20	0
or -New compressor with piping	0	100
Soak drum with motors	80	100
Flattening rollers	20	30
2 x vertical wet-mill cutters	400	500
Safety management	5	10
Ice maker	50	80
Air conditioner	20	50
Extension to building for soak silo	40	60
TOTAL PER BAKERY	645	945

Table: Capital expenditure

Scaling up is not an issue as the process has been designed to be a batch process where the bottleneck is in the soaking. It simply requires additional soak capacity (larger soak drum else more soak drums) to increase capacity.

13.2. NPV AND IRR OF WET-MILL PROCESS

The NPV and IRR calculations are based on a comparison between the normal plant bakery operational costs and the costs of introducing wet-mill bread. Some of the processes remain the same- such as baking and proving, and sales and distribution. The wet-mill process affects the mixing step only. The tables below summarise the current split of costs of a R2 loaf in a normal plant bakery and an entirely converted wet-mill bakery. The wet-mill table cost split is reflected as percentages of the standard plant bakery e.g.: all baking and distribution costs are 100% the same as a normal plant bakery, whereas the labour component of dough is 10% more expensive. Yellow cells indicate where the wet-mill process differs from the plant bakery process.

Standard					Wet-Mill				
Input percentages					Our scaling				
	Dough	Baking	Distrib	TOTAL		Dough	Baking	Distrib	TOTAL
Materials - Flour	45%	0%	0%	45%	Materials - wheat	55%	100%	100%	25%
Materials - Other	3%	0%	0%	3%	Materials - Other	100%	100%	100%	3%
Labour	8%	15%	4%	27%	Labour	150%	100%	100%	31%
Energy	4%	8%	3%	15%	Energy	110%	100%	100%	15%
Stats dep/W.Cap	3%	2%	1%	6%	Stats dep/W.Cap	110%	100%	100%	6%
SG&A	3%	2%	1%	5%	SG&A	100%	100%	100%	5%
Other	0%	0%	0%	0%	Other	100%	100%	100%	0%
TOTAL	65%	26%	9%	100%	TOTAL	49%	26%	9%	84%
Output costs					Output costs				
	Dough	Baking	Distrib	TOTAL		Dough	Baking	Distrib	TOTAL
Materials - Flour	0.90	-	-	0.90	Materials - Flour	0.50	-	-	0.50
Materials - Other	0.05	-	-	0.05	Materials - Other	0.05	-	-	0.05
Labour	0.16	0.30	0.08	0.54	Labour	0.24	0.30	0.08	0.62
Energy	0.08	0.16	0.06	0.30	Energy	0.09	0.16	0.06	0.31
Stats dep	0.06	0.03	0.02	0.11	Stats dep	0.07	0.03	0.02	0.12
SG&A	0.05	0.03	0.02	0.10	SG&A	0.05	0.03	0.02	0.10
Other	-	-	-	-	Other	-	-	-	-
TOTAL	1.30	0.52	0.18	2.00	TOTAL	0.99	0.52	0.18	1.69

Table: Standard vs. wet-mill costs break-down

Obviously an entire plant conversion is quite remote. Thus the plant saving per loaf will be somewhere between the extremes shown above. For modelling purposes an introduction of 10000 loaves per day in the plant bakery is assumed. An extract from the model is shown below and below that a table that defines in more detail the assumptions behind some of the figures.

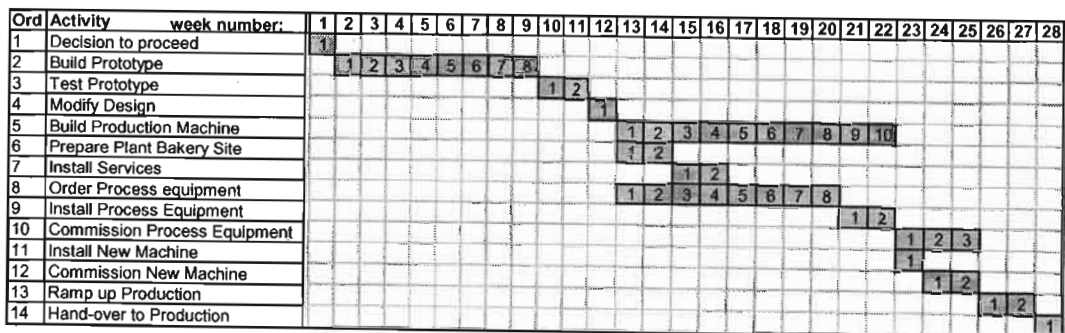
Savings per loaf		Notes
Wet mill labour R/loaf	0.25	
R/hr	17	1
Labour/loaf	0.0006	2
Labour (no. people)	6	3
Loaves/24hrs	10,000	
Plant labour R/loaf	0.01	
R/hr	17	
Labour/loaf	0.0000	4
Labour	3	5
Loaves/day	120,000	6
Flour per loaf	0.97	
R/kg	2.10	7
Flour/loaf	0.460	8
Wheat per loaf	0.56	
R/kg	1.27	9
Wheat/loaf	0.441	10
Wet mill energy/loaf	0.014	11
Wet mill energy R/day	140	
R/kwh	0.200	12
Total power (kw/day)	700	13
Plant energy/loaf	0.002	14
Mixer energy R/day	124	
Mixer energy per day	620	
Mixer kw rating	31	15
Mixing hours per day	20	16
Saved labour	(0.24)	17
Saved materials	0.41	17
Saved energy	(0.01)	17
TOTAL savings per loaf	0.16	
save per plant per day	1,597	
loaves per day	10,000	18
save per year	582,728	
Capex	(850,000)	19
IRR	63%	20
NPV	1,235,451	21

Table: NPV and IRR calculations

- 1 R3000 salary: 22 working days per month with 8 hours per day
- 2 This is labour per hour for the 10000 wet mill loaves produced
- 3 Two people on each of 3 shifts
- 4 This is labour per hour for the 120000 standard loaves produced
- 5 In a standard plant bakery there is one person in mixing per shift.
- 6 5000 loaves per hour for 24 hours.
- 7 R2.10 is what Blue Ribbon source at from Pet Kukumu at GenZFoods Isando, and is conservative as Tiger uses about R2.46 incl delivery and bulk discount.
- 8 Standard flour per loaf used in the plant bakeries
- 9 This is based on BSS at R1193-80 with R75 delivery to JHB region via road.
- 10 Wheat per loaf as determined in plant optimisation trials - see chapter 5.
- 11 Total energy requirement per loaf of replacing standard mixing with entire wet mill process.
- 12 Industrial kwh rate in the year 2000.
- 13 Total energy requirement of replacing standard mixing with entire wet mill process for the 10000 loaves only.
- 14 Mixing plant energy requirements per loaf per mixer for 120000/2 loaves.
- 15 A 'Diosna' mixer for a plant this size has a motor of 31KW.
- 16 Mixing only needs to work for 20 hours per day to supply the plant for 24 hours eg: mixing for 10 minutes, loading and offloading for 2 minutes is 20% dead time which translates into 19.2 hours energy consumption.
- 17 Savings or losses attributable to introducing the wet mill process.
- 18 The size of the wet mill plant
- 19 The capex requirement. See previous section.
- 20 Internal rate of return over 5 years.
- 21 Net present value over 5 years, with discount rate of 10%. This is very conservative as the cost of capital in organisations such as these plant bakeries is usually much lower than the repo rate. At a discount rate of 7% the NPV increases to R1.44 million.

Notes: NPV & IRR calculations

13.3. IMPLEMENTATION



Gantt Chart: Schedule of implementation

14. REGULATORY ISSUES

14.1. HACCP

HACCP can simplistically be described as the control of product safety. It arises from a need to ensure that the food product a consumer receives is consistently safe. It was first developed in the 1960s to ensure safe food for the first manned space mission and became a widely adopted procedure following a fatal outbreak of *E. coli* 0157 in Scotland in 1996. (For a more detailed account of the development of HACCP and the state of implementation in South Africa please see [Appendix I](#))

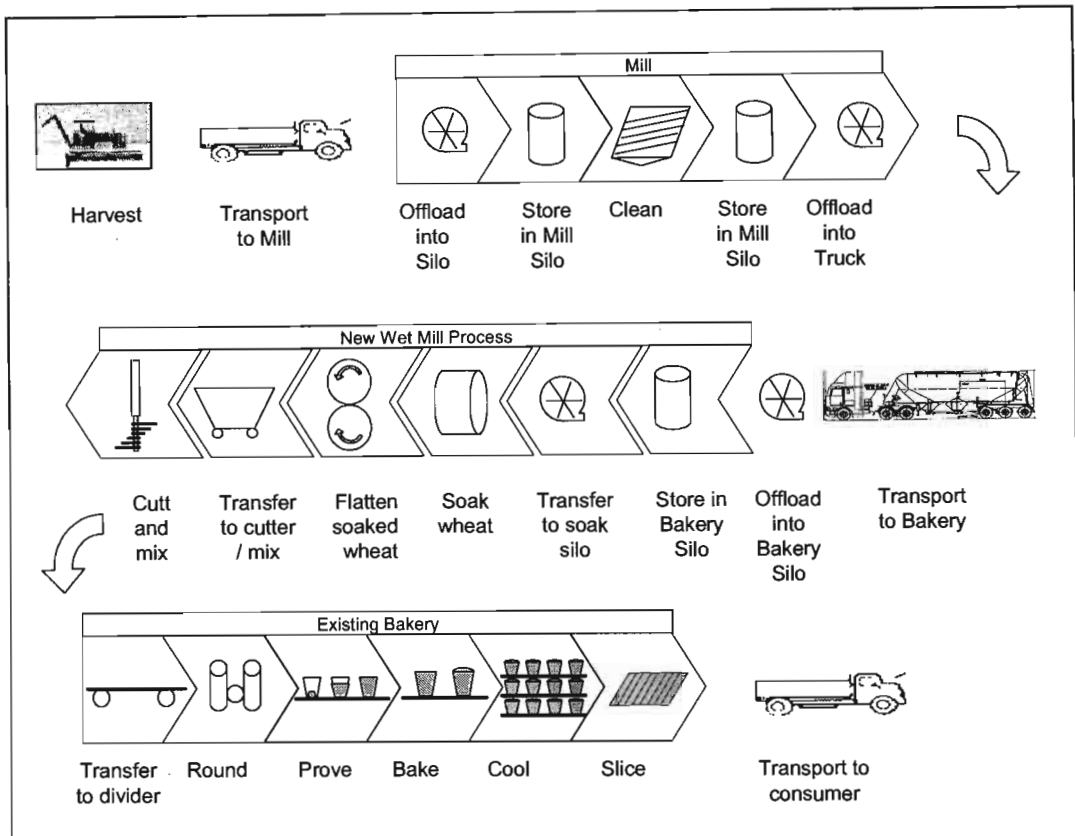
14.1.1. Implementation of HACCP

HACCP is a thorough analysis of hazards, where they occur; systems and procedures that can be implemented to minimise the hazard; and the establishment of critical control points that can be managed by appropriately trained in-house staff. A food safety programme however does not just stop with HACCP. To be effective, sub-systems such as pest control, recall protocols, hygiene and sanitation need to be developed and implemented. Additionally, the issue of ensuring that suppliers and distributors are also 'safe' needs to be addressed through the development of ingredient specifications and a vendor quality assurance system.

Before an HACCP analysis can be undertaken, a flow sheet of the process has to be generated. For the wet-mill bread it may look something like the schematic below.

Once the flow sheet accurately reflects the life-cycle of the product to the end consumer, the seven HACCP steps can then followed:

Analyze hazards. Potential hazards associated with a food and measures to control those hazards are identified. The hazard could be biological, such as a microbe; chemical, such as a toxin; or physical, such as ground glass or metal fragments. In the flow schematic above, for instance, there is a potential physical contamination of the wheat coming from the farm.



Flow sheet: Wet-mill process

Identify critical control points. These are points in a food's production—from its raw state through processing and shipping to consumption by the consumer—at which the potential hazard can be controlled or eliminated. Following the contaminated wheat example, metal detection following the cleaning process would then be a critical control point (CCP).

Establish preventive measures with critical limits for each control point. For a cooked food, for example, this might include setting the minimum cooking temperature and time required to ensure the elimination of any harmful microbes.

Establish procedures to monitor the critical control points. In a mill, the read-out of a metal detector would be recorded in a database for long term record keeping. In another environment, this might require someone to come and look at a gauge and manually record relevant data.

Establish corrective actions to be taken when monitoring shows that a critical limit has not been met- for example, isolating and disposing of wheat that did not pass the metal detector.

Establish procedures to verify that the system is working properly—for example, testing each day that the metal detector is correctly calibrated and able to identify standard test pieces of metal.

Establish effective recordkeeping to document the HACCP system. This would include records of hazards and their control methods, the monitoring of safety requirements and action taken to correct potential problems.

An example of what a HACCP analysis may look like for the new wet-mill process can be seen below.







New Wet Mill Process						
						
	Store in Bakery Silo	Transfer to soak silo	Soak wheat	Flatten soaked wheat	Transfer to cutter / mix	Cutt and mix
Analyze hazards.	Physical contamination via open man-hole	None as a closed system. System must be hygienically designed	Soaked wheat left too long and starts to sprout and / or ferment	Physical contamination from dirty rollers.	Product open to air / bird droppings / people touching	Physical contamination from air lubricant. Mixing otherwise covered
Identify CCPs.	None	None	Wheat sample point	None	None	None
Preventive Measures	Man-hole to be inspected daily or be wired that if it is open for an extended period an alarm sounds	None required	Shut down procedures should ensure that there is never any wet wheat left in the soak vessel	Rollers should be hygienically cleaned at least once per day	The flattening procedure should occur indoors with avian control policy	Ensure hygienic design on new machine, also use food grade lubricant in air system
Monitoring Procedure	None	None	Samples of the wheat should be taken before each batch and checked for sprouting	None	None	None
Corrective Actions	None	None	That batch testing positive for sprouting should be rejected	None	None	None
System working?	None	None	There should be no baked bread issues linked to sprouted wheat	None	None	None
Record Keeping	None	None	The batch number, date and time of the sample and the outcome of the test should all be recorded	None	None	None

Table: HACCP analysis sheet

14.2. HAZOP

The Hazard and Operability Study (HAZOP), has been used and developed over approximately four decades for 'identifying potential hazards and operability problems' caused by 'deviations from the design intent' of both new and existing process plants.

'Deviation' is not, however, the same as 'failure'. For example, if the design intent of a facility was to circulate chilled water through a cold store (it is understood the intent would also be to conduct the operation in the safest and most efficient manner possible), then a deviation from the design intent would be a cessation of circulation, or a temperature increase of the water. In this case, the failure of the pump would be a cause, not a deviation.

A Hazop study systematically questions every part of a system to establish how deviations from the design intent can arise. Once identified, an assessment is made as to whether such deviations and their consequences could have a negative effect upon the safe and efficient operation of the plant. If considered necessary, action is then taken to remedy the situation.

This critical analysis is applied in a structured way by the Hazop team, and it relies upon them utilising their imagination in an effort to discover credible causes of deviations. In practice, many of the causes will be fairly obvious, such as pump failure causing a loss of circulation in the cooling water facility mentioned above. However, the great advantage of the technique is that it encourages the team to consider other less obvious ways in which a deviation may occur, however unlikely they may seem at first consideration.

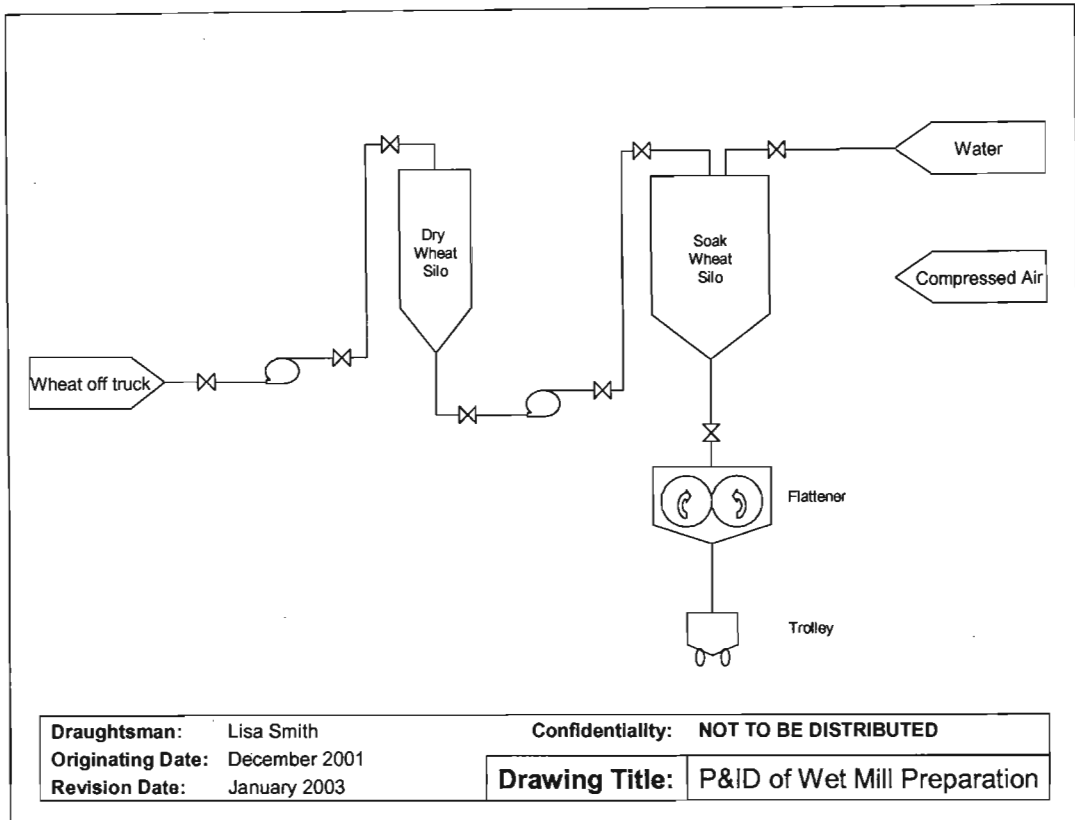
14.2.1. Keywords

The HAZOP methodology is to use Key words to create scenarios that are then brainstormed as to their consequence, possible hazard, cause and potential remedy. The keywords (such as flow, temperature) reflect both the process design intent and operational aspects of the plant being studied.

Secondary keywords are used in conjunction with primary keywords to suggest a potential deviation which might lead to failure.

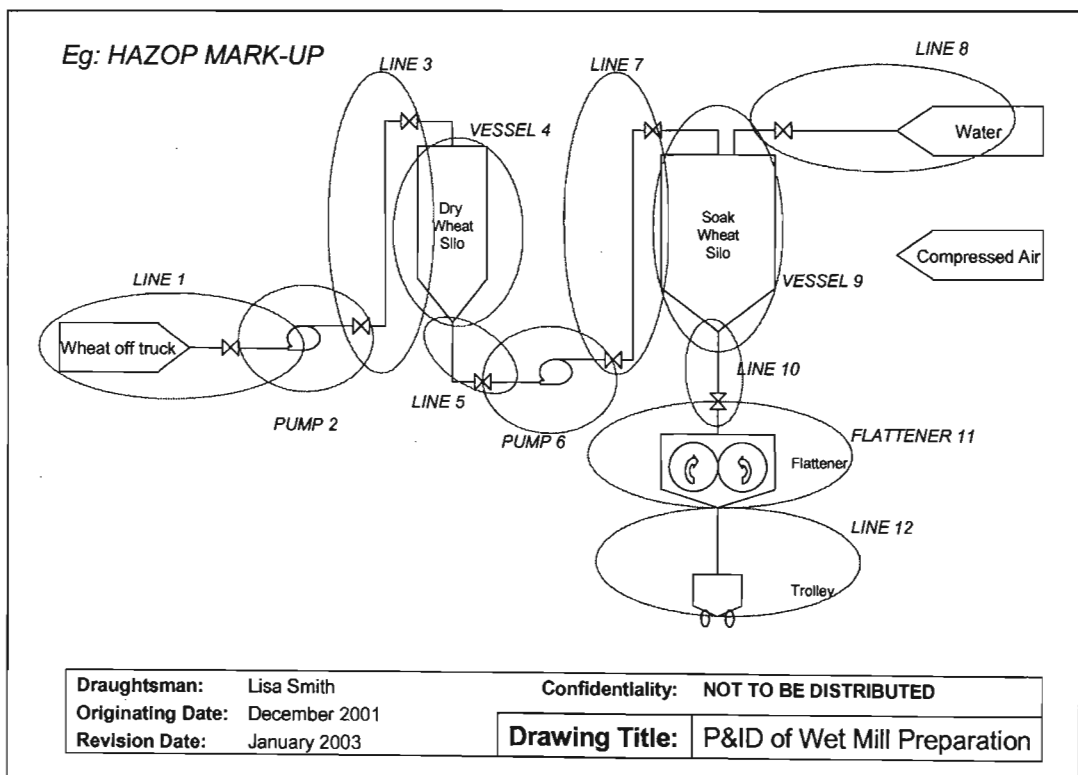
For example using Flow as the Primary keyword: No Flow, Less Flow, More Flow.

The wet-mill PI&Ds is shown below:



Drawing: P&ID Wet-mill Preparation

Now the P&ID can be marked up for a HAZOP study:



Drawing: Marked-up P&ID for HAZOP

In simple terms, the Hazop study process involves applying in a systematic way all relevant keyword combinations to the plant in question in an effort to uncover potential problems. The results are recorded in columnar format under the following headings:

DEVIATION	CAUSE	CONSEQUENCE	SAFEGUARDS	ACTION
-----------	-------	-------------	------------	--------

The definitions of the above headings can be found in Appendix I.

An example HAZOP sheet for the wet-mill process is included below. The 'line' column refers to the process lines delineated on the P&ID above.

HAZOP RESULT SHEET

Date: January 2003

Plant WET-MILL INSTALLATION		Secretary: LISA SMITH		
Drawings referred to P&ID of Wet Mill Preparation		Team Names: LISA SMITH		
Equipment		Properties: Flow Pressure Temperature		
Equipment Tag Numbers		Guide Words: No More Less Opposite Also Other (Early Late)		
Special conditions for Hazop: none, start-up, abnormal operation, maintenance, other (details):				
Line	Deviation	Cause	Consequences	Action
1	No/Less Flow = low pressure	Valve before pump partially/closed, pump not working, pipe blocked	Slow off loading of truck, stall pump. NOT CRITICAL	Check valve open, pipe clear and pump working b4 offloading truck
2	Not start	Power supply off	Wheat not offloaded from truck. NOT CRITICAL	No action required
	Maintenance	Able to isolate pump with valve before and after		No action required
	More Pressure	Valve after pump is closed, pipe is blocked upstream	Air is compressible – but if have a big compressor then could burst pipe	Insert a pressure relief valve before pump isolation valve.
	Opposite flow	Pump wired incorrectly	Air pumped into truck. Wheat will not offload.	Ensure that wheat delivery vehicles equipped with pressure relief valves.
3	No/Less flow	Valve before silo partially/closed, pump not working	Slow off loading of truck. NOT CRITICAL	Check valve open, pipe clear and pump working b4 offloading truck
	More Pressure	Valve before silo closed, pipe blocked	Air is compressible – but if have a big compressor then could burst pipe	Insert a pressure relief valve before silo isolation valve.
4	Maintenance	Able to isolate silo with valve before and after		No action required
	No Flow	Silo ext blocked/ wheat bridged	Process starved of wheat	Install manhole access point into base of silo. Install automatic knockers if problem persists to prevent bridging

Table: HAZOP example for first 4 lines

Once the HAZOP analysis has been completed, a report needs to be submitted – the most important part of this is an action list of items that need to be completed within a specific time frame and by a specific person. The commitment of various departments to completing this action list will largely depend on the team used to compile the report. I.e: the team that completes the HAZOP study needs to have the respect and buy-in of the various departments. Some more comments regarding the contents of the report and the HAZOP team can be found in Appendix I.

14.3. SAFETY REGULATIONS

The Occupational Health and Safety Act (act no 85 of 1993) states quite clearly in section 10 that “a person who designs, manufactures or supplies any article shall ensure that it is safe when properly used”. The act’s corollary regulations then specify more clearly what is required.

The General Machinery Regulation (GMR 3) aims to “prevent the exposure of persons to hazardous conditions”, “in particular every exposed and dangerous part of machinery which is within the normal reach of a person is to be effectively guarded”. This regulation further requires that “devices to start and stop machines be in a position where they can be readily and conveniently reached” (GMR 6-1) and be arranged “as to prevent the accidental starting of such machinery”. GMR 6-3 also specifically requires that the motor of any driven machinery be ‘isolatable’ for maintenance.

Another relevant piece of design regulation is the Driven Machinery Regulation (DMR). DMR 11 specifically addresses mixing type of machines and requires that they are safeguarded such that “the machine will come to a stop if any one of them (safety guards) is opened, unlocked or removed”.

There are further environmental requirements dealing with issues such as noise exposure and waste procedures.

The points raised above go some way towards completing a design “in context” as Juvinall would have us do – but this is by no means a comprehensive list of the regulations relevant in this case.

15. CONCLUSION

The three research areas have been addressed in detail.

Product development

A successful product was developed that met both consumer taste and texture requirements, was robust enough to survive in a plant bakery environment and at an ingredient cost advantage that offset the extra plant capital that would be required to implement the technology. The product was successfully proved at a 50kg scale. Further recipe and cutting time optimisation will be required when the plant-bakery wet-mill cutter is produced as scale will affect these parameters.

Process development

A complete production process was designed that takes wheat from trucks and turns it into dough that seamlessly continues downstream in the bakery. The final process was designed for integration into a 5000 loaves an hour plant. It was crucial that the installation did not interrupt established plant bakery product flow dynamics. It had to be easily managed with limited extra labour requirements. The process was checked using both HACCP and HAZOP procedures. The process was optimised to limit operational cost: this not only involved a comprehensive recipe optimisation, but also an analysis of various chilling options to provide the least cost temperature management. The total installation was optimised to minimise capital cost

Machine design

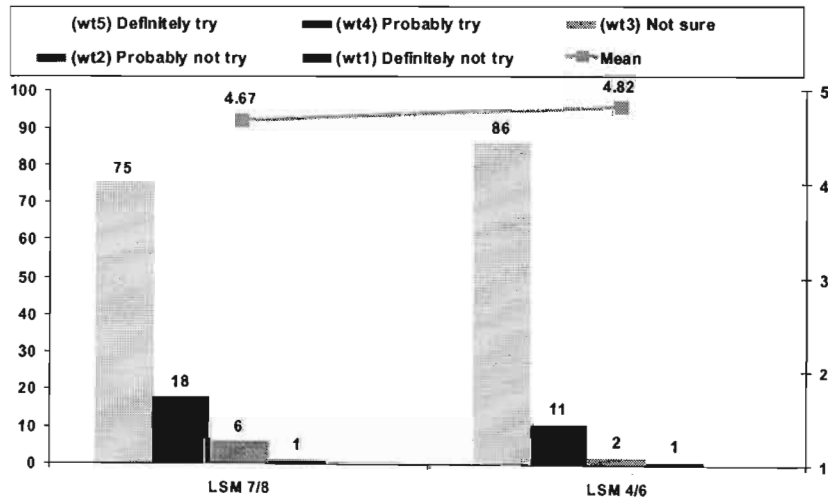
A comprehensive design of the vertical wet-mill cutter has been completed. All parts were optimised in some way whether in material selection, strength, wearing life or safety. The blades, for instance, were optimised with respect to stress, wearing life and cost of maintenance. It must be noted that this design is a prototype and, once built, should be tested and modifications to the design carried out where necessary.

The consumer feedback on the bread product is positive. The financials indicate that the plant baker should be interested. A new machine has been designed to enable the introduction of the technology. There is every reason to go on and build the scaled machine, test, modify and implement!

APPENDICES

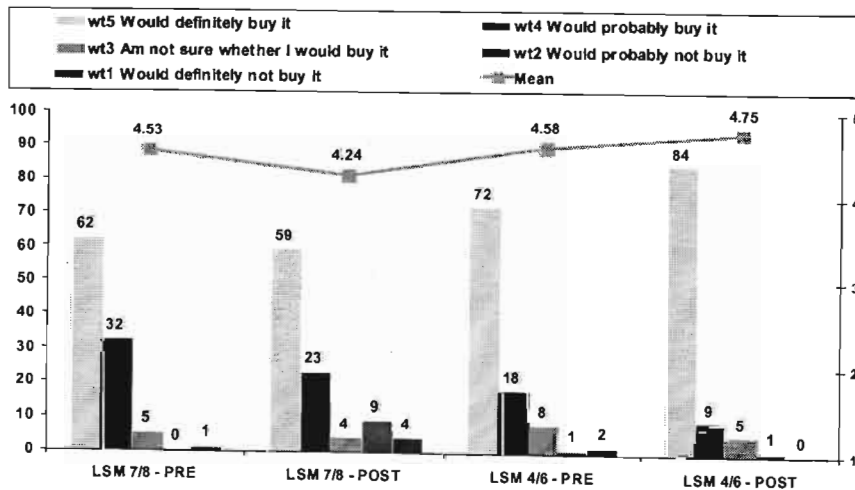
APPENDIX A: MARKET RESEARCH DATA

Willingness to try the product was high, ...



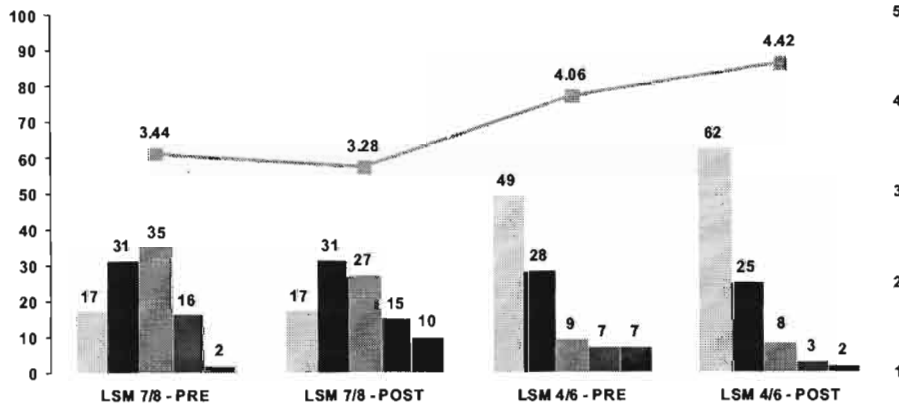
Source: sponsored bread market research

...as was the intention to purchase



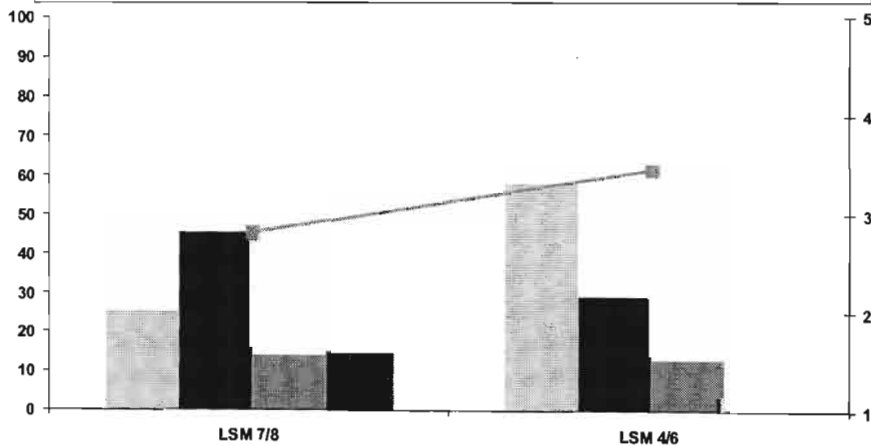
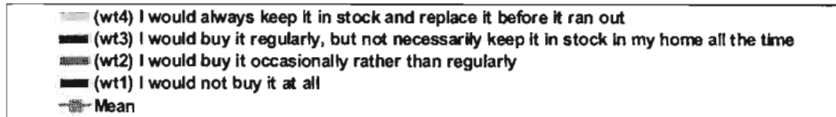
Source: sponsored bread market research

LSMs 4-6, especially, found the proposition unique, ...



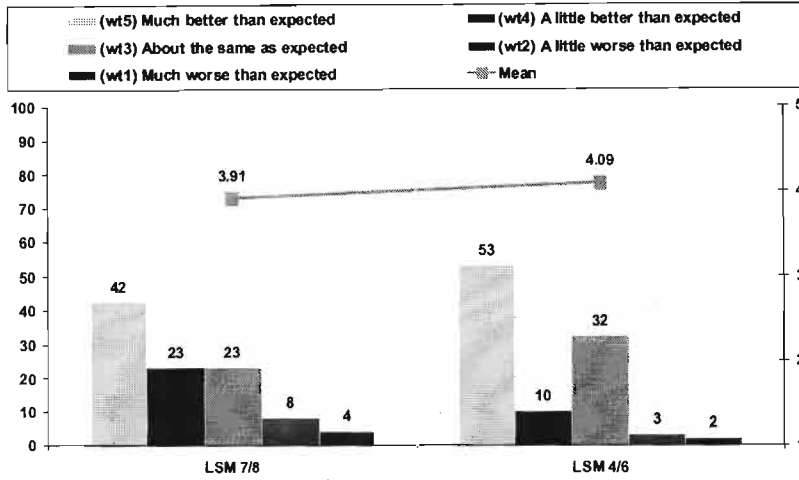
Source: sponsored bread market research

...reflected in a high readiness to keep the product in stock



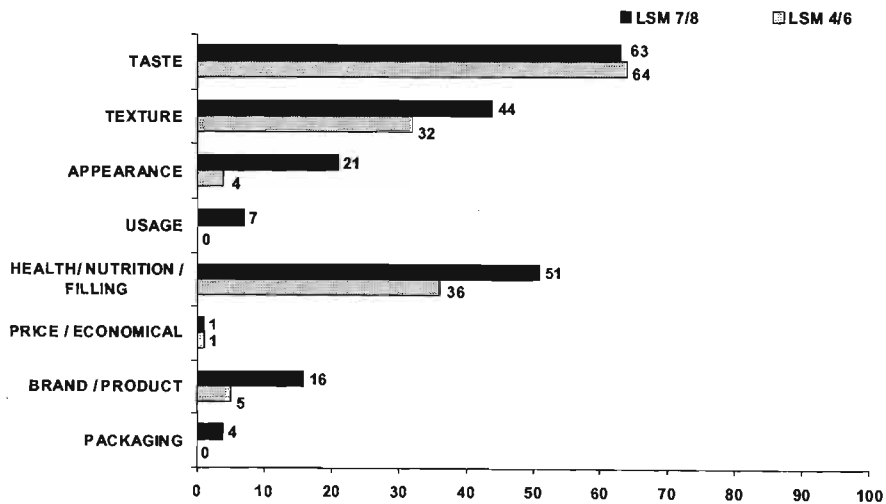
Source: sponsored bread market research

Most consumers found the product better than expected, ...



Source: sponsored bread market research

...mentioning taste, texture and nutrition/filling as the main reasons



Source: sponsored bread market research

APPENDIX B: NUTRITIONAL ANALYSIS & SGS REPORT



PO Box 5472
Halfway House
1685
Gauteng, South A

Tel: +27 (11)
Fax: +27 (11)
Telex: 4-86287

Reg No: 05/32643A

S A N A S



ACCREDITED
LABORATORY

TESTING LABORATORY No. T0115

LABORATORY TEST REPORT

Ref. No.00/04736

Attention : Cella van den Oever

Date Received: 07 September 2000
Date of Report: 29 September 2000

SAMPLE DESCRIPTION

1	Brown Bread
---	-------------

RESULTS:

Analysis	Units	Sample 1	Repeat	Bread 1	Bread 2	Bread 3
Protein (N x 6.25)	g/100g	9.88		9.20	9.60	9.60
Fat (Acid hydrolysis)	g/100g	5.40		3.60	4.16	4.40
Ash (Total)	g/100g	1.37				
Moisture (Total)	g/100g	35.43				
Total Dietary Fibre	g/100g	9.87		4.40		6.40
Carbohydrates (Total)	g/100g	47.92		52.00	45.83	44.00
Energy (Total)	g/100g	1134.48				
Potassium	g/100g	0.18				
Iron	mg/Kg	40.50				
Magnesium	mg/Kg	40.00				
Zinc	mg/Kg	21.00				
Calcium	g/100g	<0.01	0.03	0.064	0.056	0.125
Phosphorus	g/100g	0.24				
Manganese	mg/Kg	17.50				

Members of the SGS Group (Société Générale de Surveillance)

Directors: P.M. Falzer, Managing Director, (Swiss); S. Depallens (Swiss); Y. Dusanchet, (Swiss); J.L. Debuysse (French).

Results: Vitamins

Analysis	Units	Sample 1	Bread 1	Bread 2	Bread 3
Vitamin B1(Thiamine)	mg/100g	0.46	0.40	0.45	0.36
Vitamin B3 (Niacin)	mg/100g	4.58	3.33	4.56	4.00
Vitamin B6 (Pyridoxamine)	mg/100g	0.36	0.08	0.13	0.20
Vitamin B5 (Pantothenic Acid)	mg/100g	0.42		0.41	0.80
Biotin	Mg/Kg	ND			
Vitamin E (a-Tocopherol)	IU/100g	12.36			

- ND = None Detected


ASHLEIGH SWARTZ
MICROLAB SUPERVISOR

* Denotes an Accredited test method. All other tests fall out of the scope of Accreditation

This report shall not be reproduced, except in full, without the written approval of the Laboratory Manager.

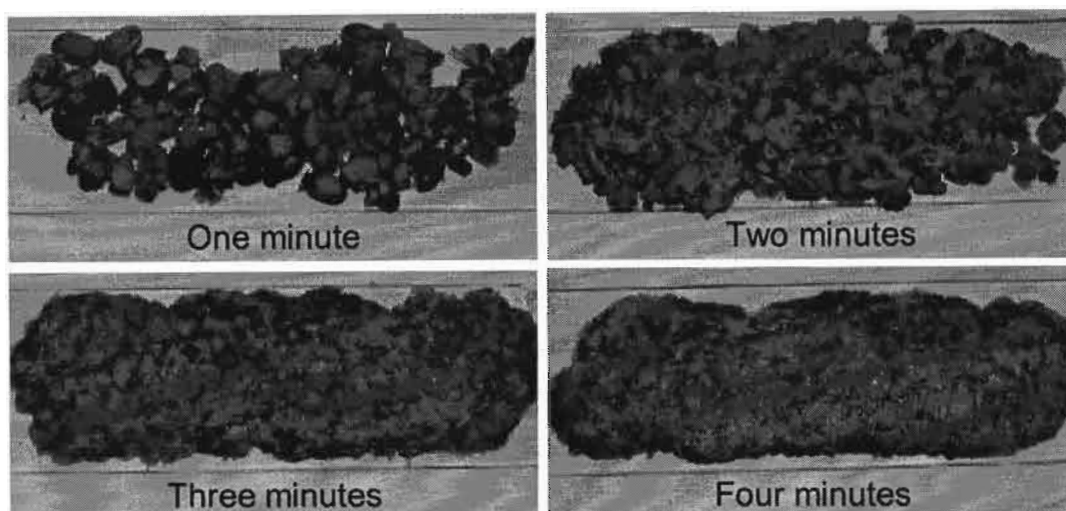
Analysis results relate to samples submitted for testing only.

This report is issued by the Company under its General Conditions for Inspection and Testing Services (copy available on request). The issuance of this report does not exonerate the buyers or sellers from exercising all their rights and discharging all their liabilities under the Contract of Sale. Stipulations to the contrary are not binding on the Company. The Company's responsibility under this report is limited to proven negligence and will in no case be more than ten times the amount of the fees or commission.

Members of the SGS Group (Société Générale de Surveillance)

Directors: P.M. Fatzer, Managing Director, (Swiss); S. Depallens (Swiss); Y. Dussochet, (Swiss); J.L. Debuyser (French).

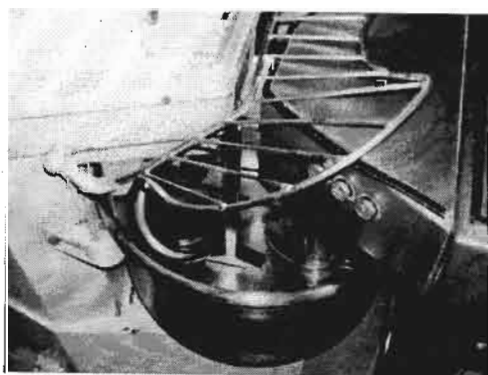
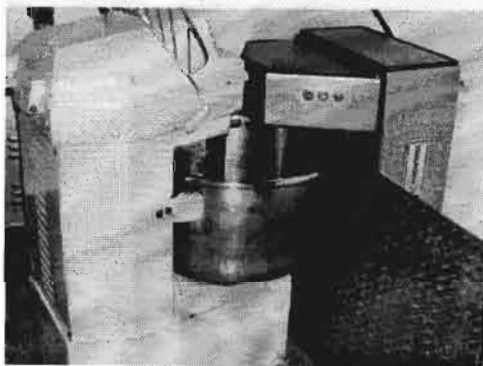
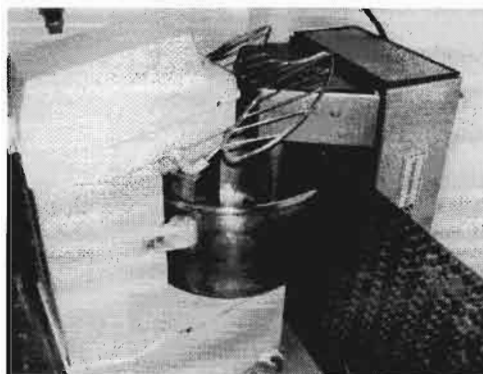
APPENDIX C: FORMATION OF DOUGH



Picture: Formation of dough during first four minutes

The formation of the dough during a bowl cut can be seen in the pictures above. As the grains are cut, so the gluten rich endosperm is released and the wheat start to become sticky. As the cut becomes finer, so the mass becomes stickier until it behaves like normal bread dough.

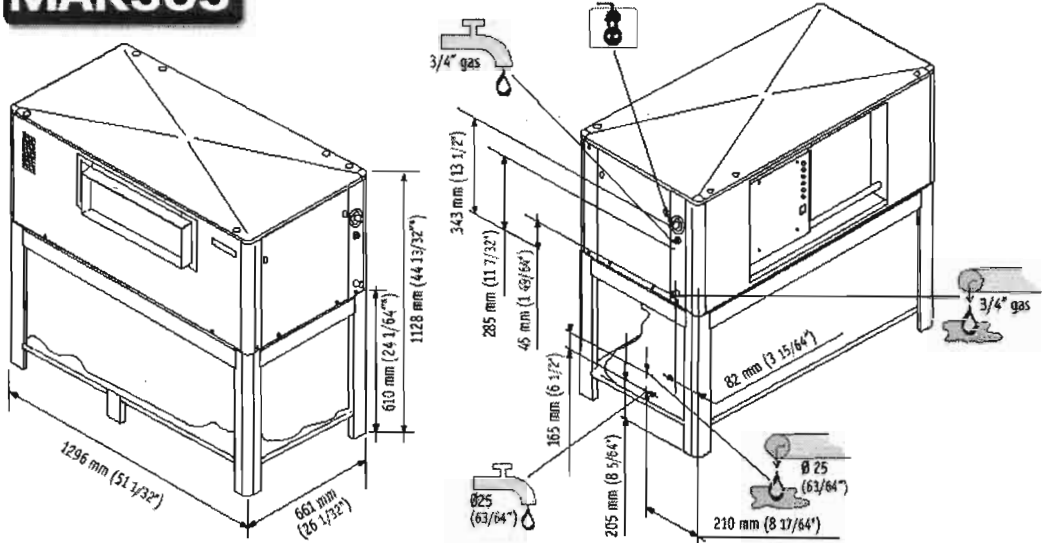
APPENDIX D: VERTICAL WET-MILL CUTTER RIG



Picture: Wet-mill rig

APPENDIX E: SCALE ICE MACHINE

MAR305



	Cond. +56.5°C / Evap. -23.3°C	[W]	[Btu/h]	[5 mm ²]	[AWG]	[W]	FUSE	[kWh]	[l/h]	[gal/h]	[kg]	[lbs]	[kg]	[lbs]
MAR 305 WS		15100	51500	5 x 4	AWG 11	8000	24A	8x24	1600	352	390	860	413	910
MAR 305 WS-SW		15100	51500	5 x 4	AWG 11	8000	24A	8x24	1600	352	390	860	413	910
MAR 305 ASR		15100	51500	5 x 4	AWG 11	9000	32A	9x24	104	23	360	794	383	844

MAR 305 AS

°F	90°	70°	60°	50°	lbs
50°	4190	4300	4410	4520	kg
15°	1900	1850	2000	2050	kg
32°	4101	4160	4278	4388	lbs
21°	1860	1800	1640	1980	kg
80°	3660	3740	3837	3925	lbs
32°	1660	1700	1740	1780	kg
100	5374	2462	3950	3638	lbs
38°	1520	1570	1610	1650	kg

THICK ICE

MAR 305 WS

°F	90°	70°	60°	50°	lbs
50°	2969	4410	4831	4851	kg
15°	1800	2080	2109	2700	kg

THICK ICE

Minimum	Maximum
10°C (50°F)	40°C (104°F)
5°C (41°F)	35°C (95°F)
-10%	+10%
1 BAR 14 psi	5 BAR 70 psi

Machine requires voltage indicated on rating name plate. Failures caused by improper voltage are not considered factory defects. Scotsman products are not designed for outdoor installation. Extended periods of operation at temperatures exceeding the above limitations consist uses outside under the terms of Scotsman Limited Warranty, resulting in a loss.

La macchina deve essere raccordata conformemente al voltaggio indicato sulla placca signalitica. Gli eventuali danni causati da un non rispetto di questa consigna non possono essere considerati come difetti di fabbricazione. Le macchine a ghiaccio Scotsman non sono progettate per essere utilizzate all'esterno. Un funzionamento prolungato a temperature superiori a quelle indicate o inferiori a quelle indicate non sono considerati come un'errata utilizzazione nel quadro della garanzia Scotsman.

Der Eisbereiter benötigt eine Stromspannung gemäß Geräte-Typenschild. Störungen oder Ausfälle, durch den Betrieb mit falscher Stromspannung sind keine Fabrikationsfehler und fallen nicht unter Garantie. Scotsman Eisbereiter sind nicht für die Installation im Freien geeignet. Der längere Betrieb bei Temperaturen über den obigen Grenzwert ist eine falsche Anwendung und bedeutet den Verlust der Garantieleistung.

Los requerimientos eléctricos de la máquina están indicados en la placa de características. Los daños causados por voltajes inadecuados no son considerados defectos de fábrica. La máquinas de hielo Scotsman, no están diseñadas para trabajar a la intemperie. Largos períodos de funcionamiento a temperaturas que excedan de las limitaciones indicadas, constituyen maltrato de acuerdo con las observaciones de Scotsman.

La macchina richiede il voltaggio indicato sulla targhetta di identificazione. Danni causati da voltaggi diversi non sono considerati difetti di produzione. I prodotti Scotsman non vanno utilizzati all'aperto. Un prolungato periodo di utilizzo al di fuori delle temperature indicate non è consentito e causa l'automat�o decadere della garanzia.



USA, Canada, Central and South Africa
Scotsman Ice Systems USA
777 Carpenter Woods Parkway
Vermont Hills, IL 60060
Ph: (847) 215-4536
Fax: (847) 911-9844
E-Mail: customer.service@scotsman-ice.com

Europe, Middle East and Africa
Scotsman Europe - Frantoni S.p.A.
Via Paccini, 22
28010 Bertolino di Pogiano (Milano) Italy
Ph: (+39) 02-93961268
Fax: (+39) 02-93961261
E-Mail: scotsman@frantoni.it

Asia and Pacific
Scotsman Ice Systems-Frantoni S.p.A. (R.O.)
321 Orchard Road #08-05
Singapore 238866
Ph: (+65) 738 5393
Fax: (+65) 738 1939
E-mail: scotsice@frantoni.sg

China
Scotsman Ice Systems
258 Ting Ren Road Golden Tower 7A
Shanghai - People's Republic of China
Ph: (+86) 21-62476166
Fax: (+86) 21-62476126
E-mail: scotsmansh@online.sh.cn

South Africa
Scotsman Ice Systems S.A. Pty. Ltd.
69, Audley Road - 2021 Beyersson
P.O. Box 44-2149 Riverchub-South Africa
Ph: +27-11-46302445
Fax: +27-11-46314111
E-Mail: tel@scotsmansa.co.za

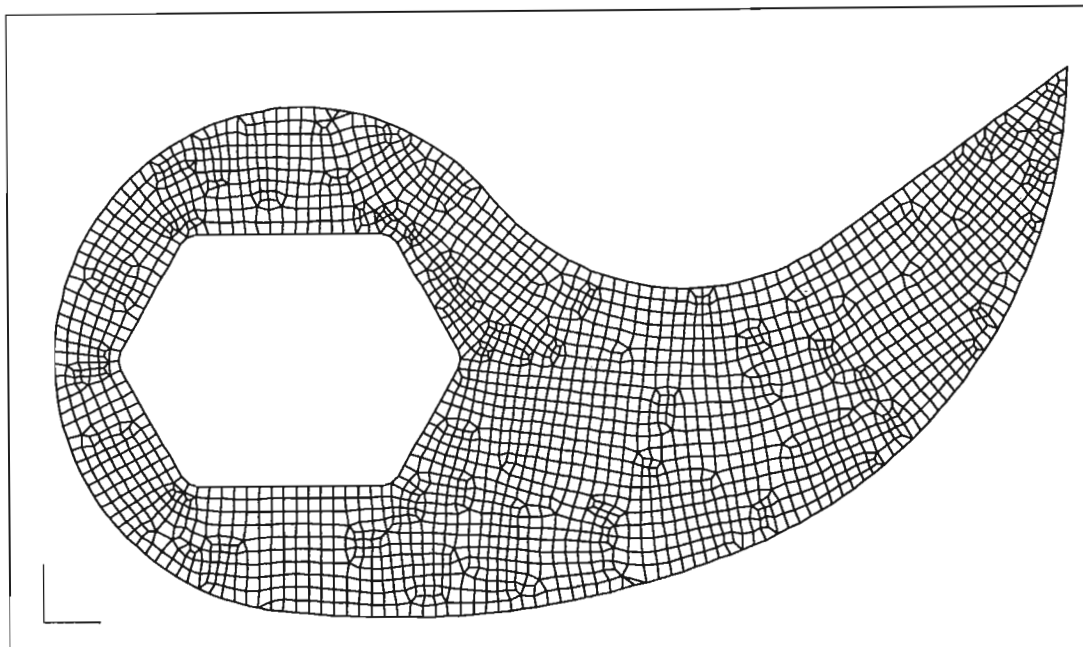
APPENDIX F: FEA DRAWINGS

Figure: Old blade FEM mesh (XY plane).

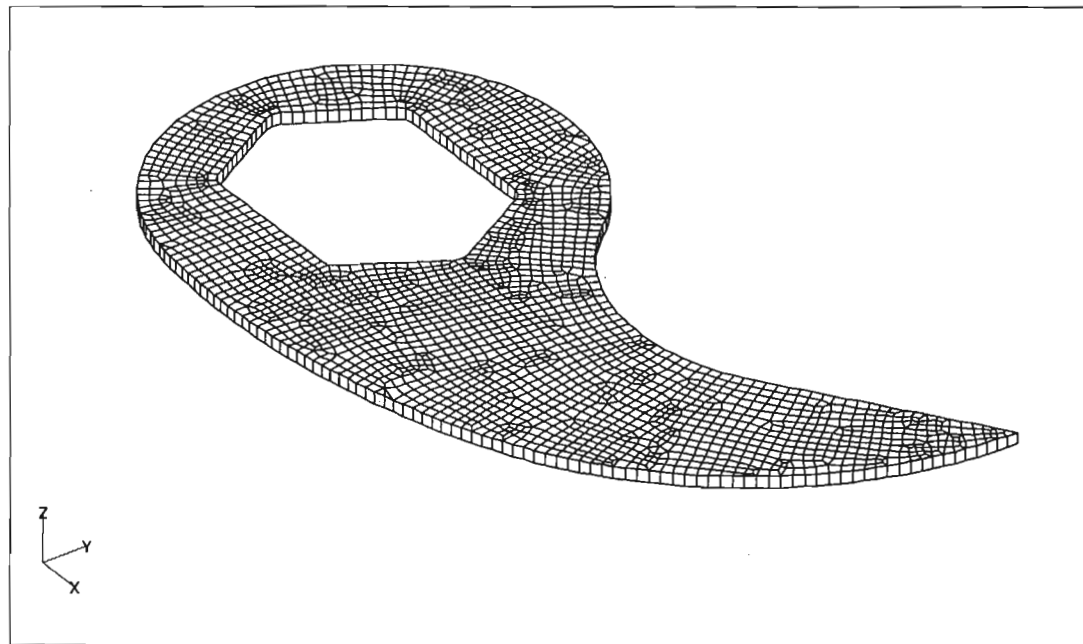


Figure: Old blade FEM mesh (Isometric view).

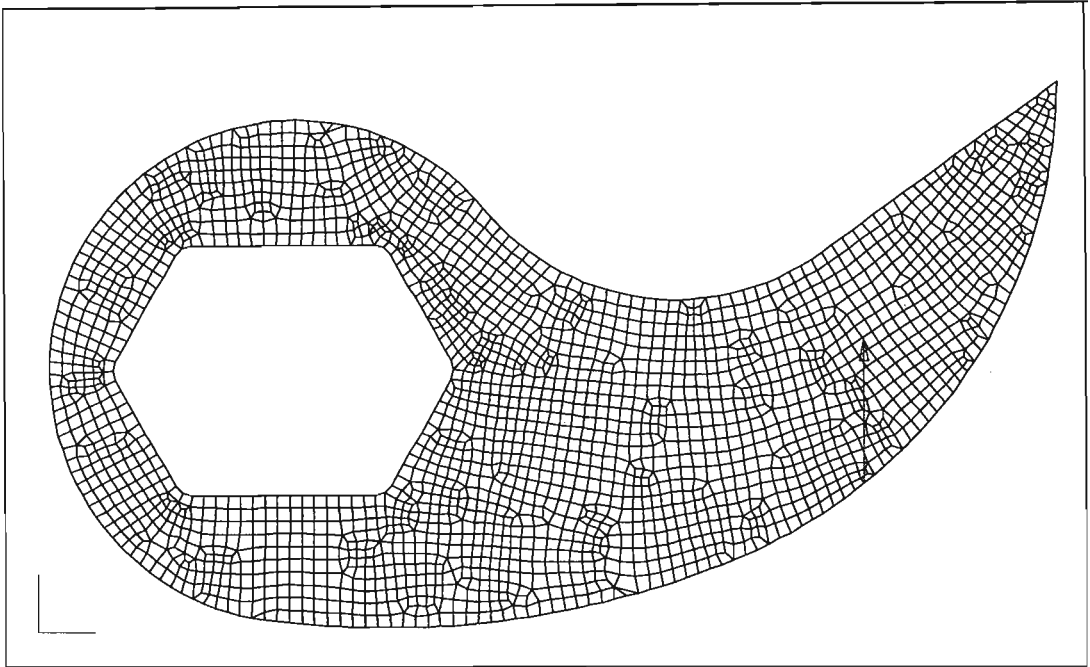


Figure: Old blade point load 100 N @ 90 mm from the centre of rotation.

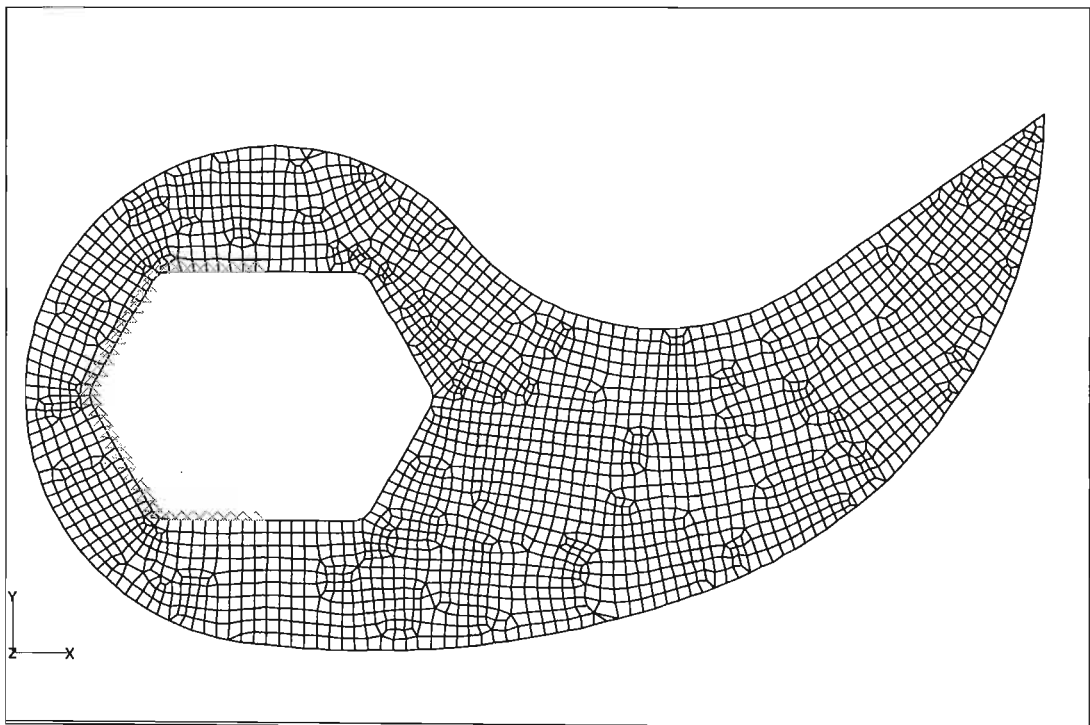


Figure: Old blade fully fixed nodes.

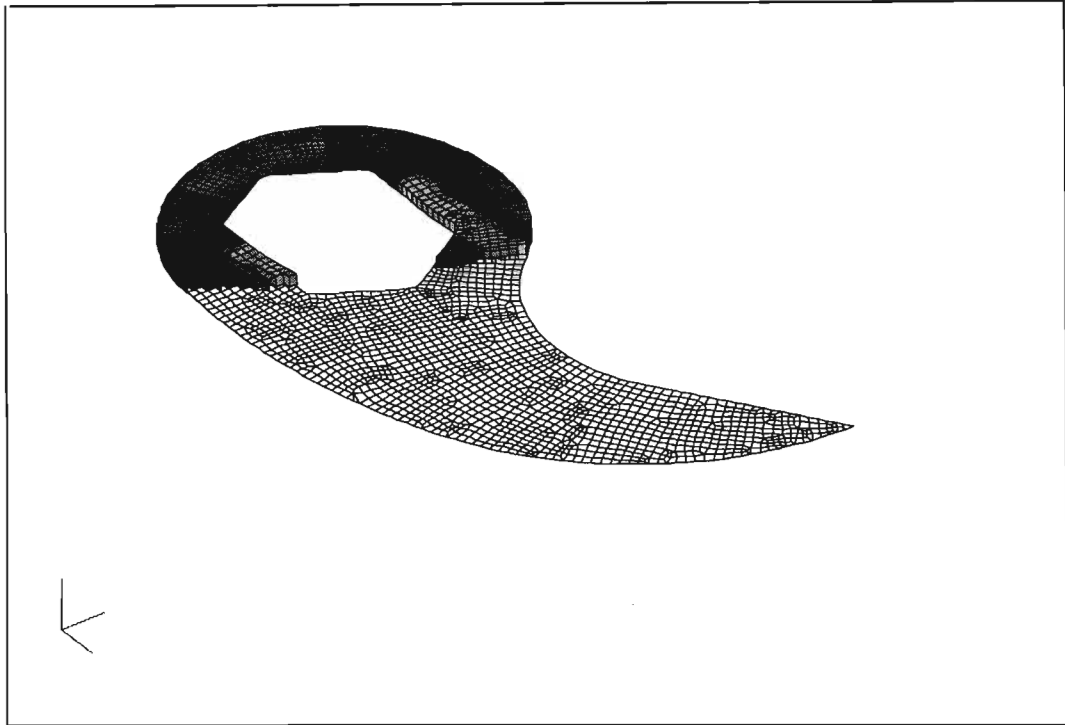


Figure: Old blade Von Mises Stress Plot, Pa (Isometric view).

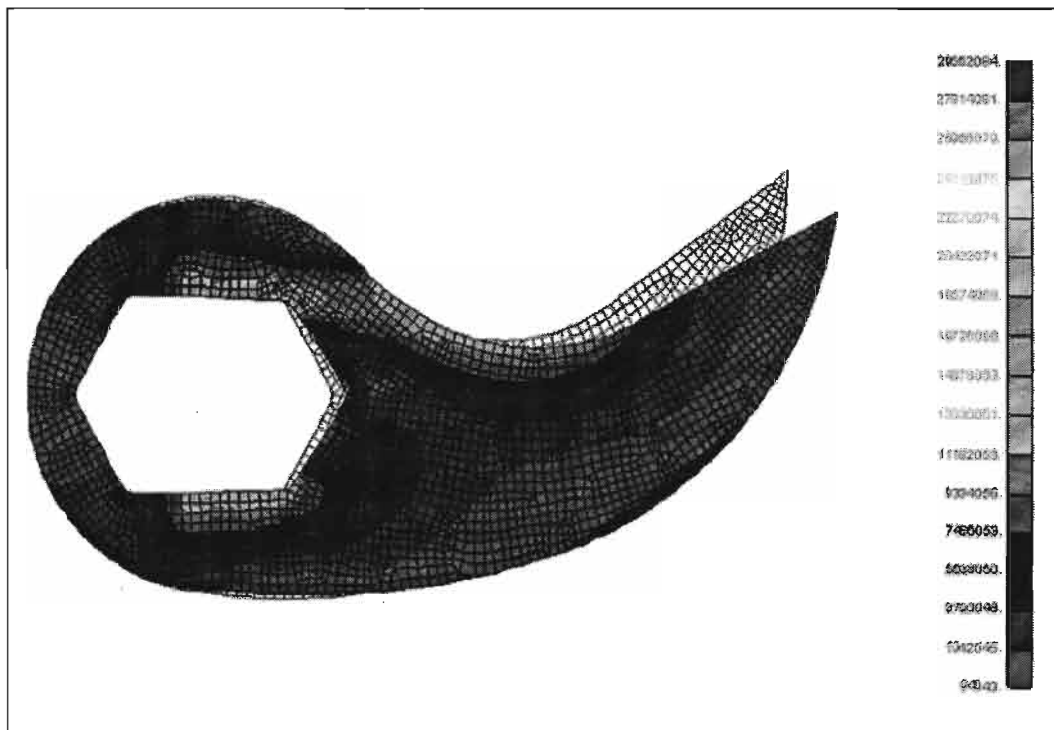


Figure: Old Blade Von Mises Stress Plot, Pa. The deformed model is shown (XY view).

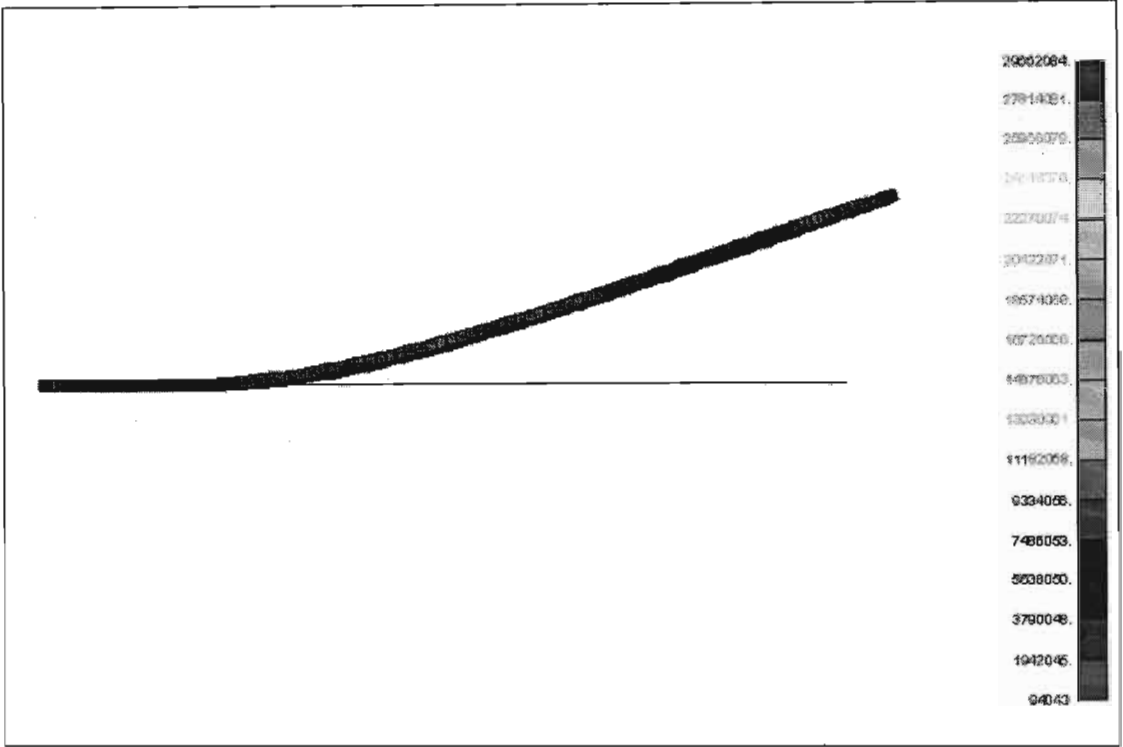


Figure: Old blade Von Mises Stress Plot, MPa. The deformed model is shown (ZX view)

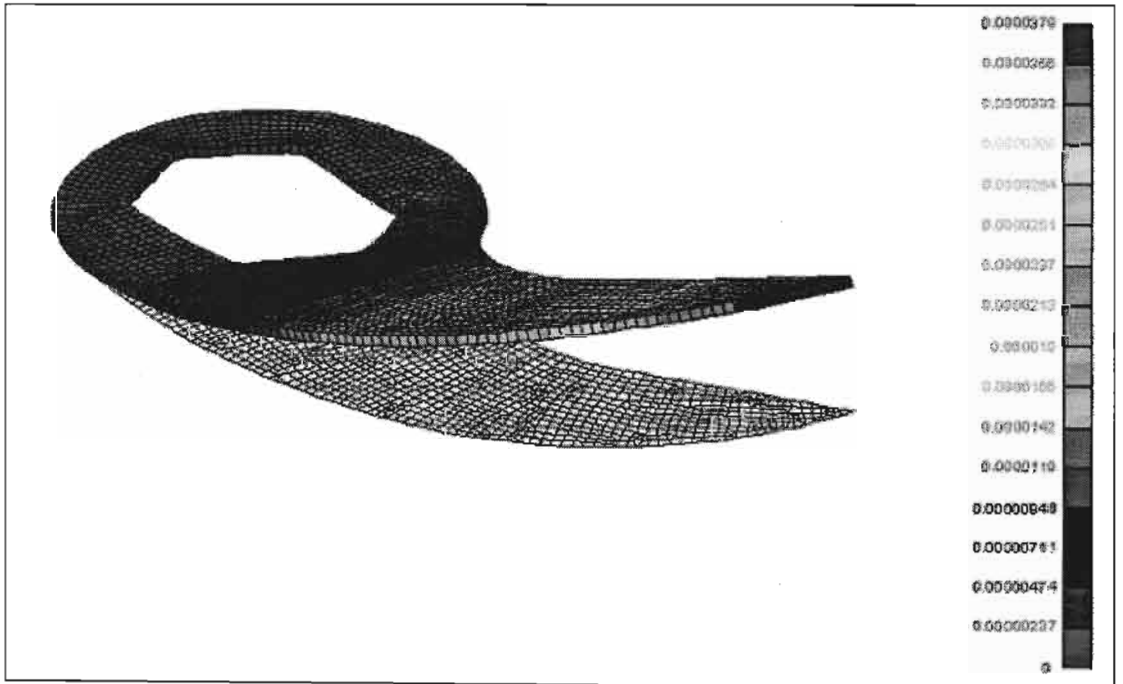


Figure: Old blade total translation, mm (Isometric view)

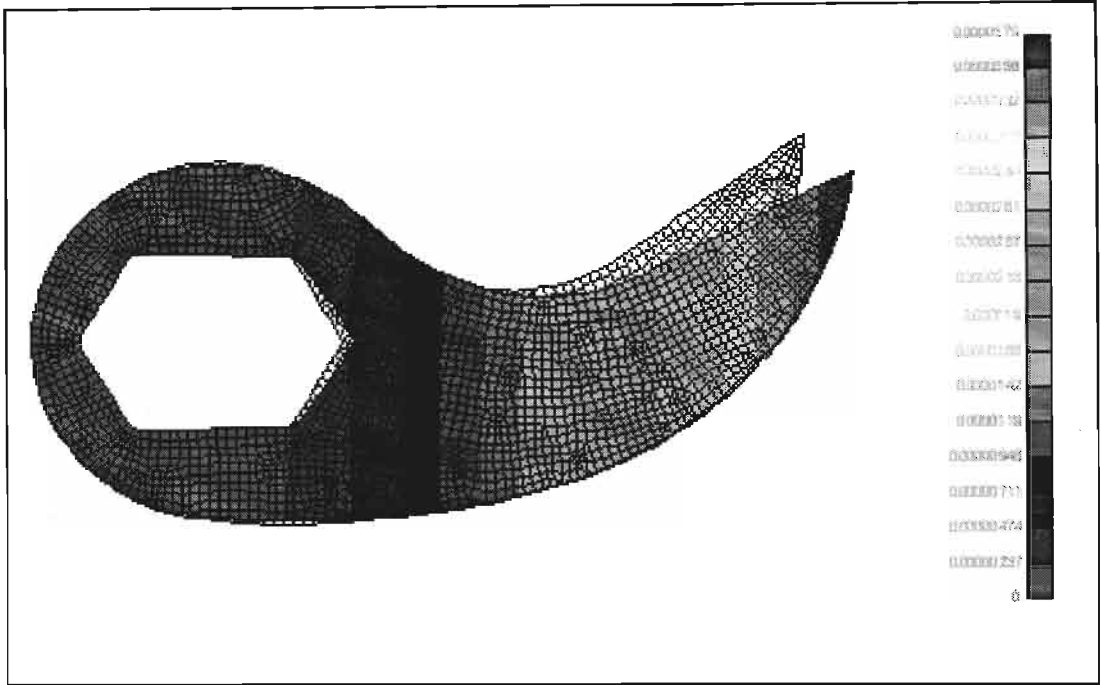


Figure: Old blade total translation, mm. The deformed model is shown (XY view)

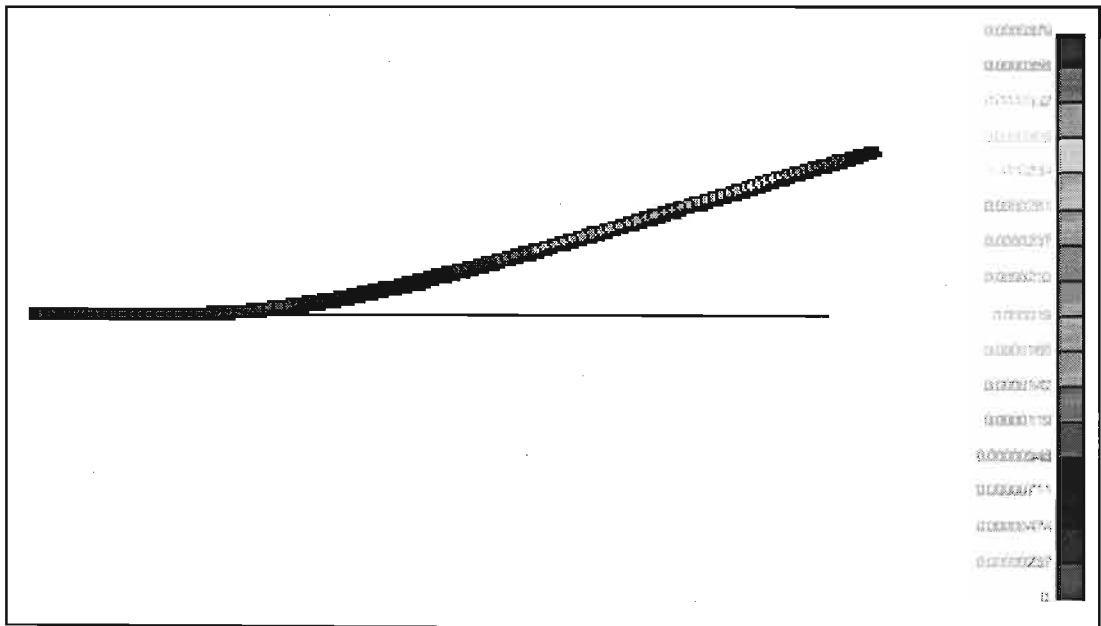


Figure: Old blade total translation, mm. The deformed model is shown (ZX view)

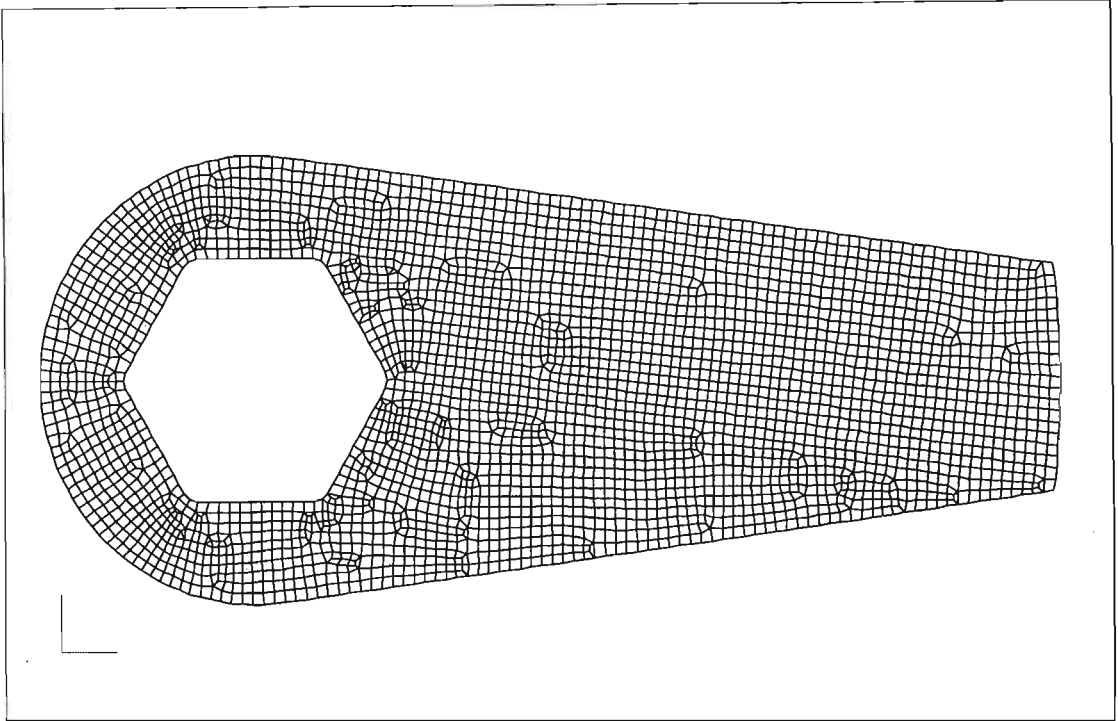


Figure: New blade FEM mesh (XY plane).

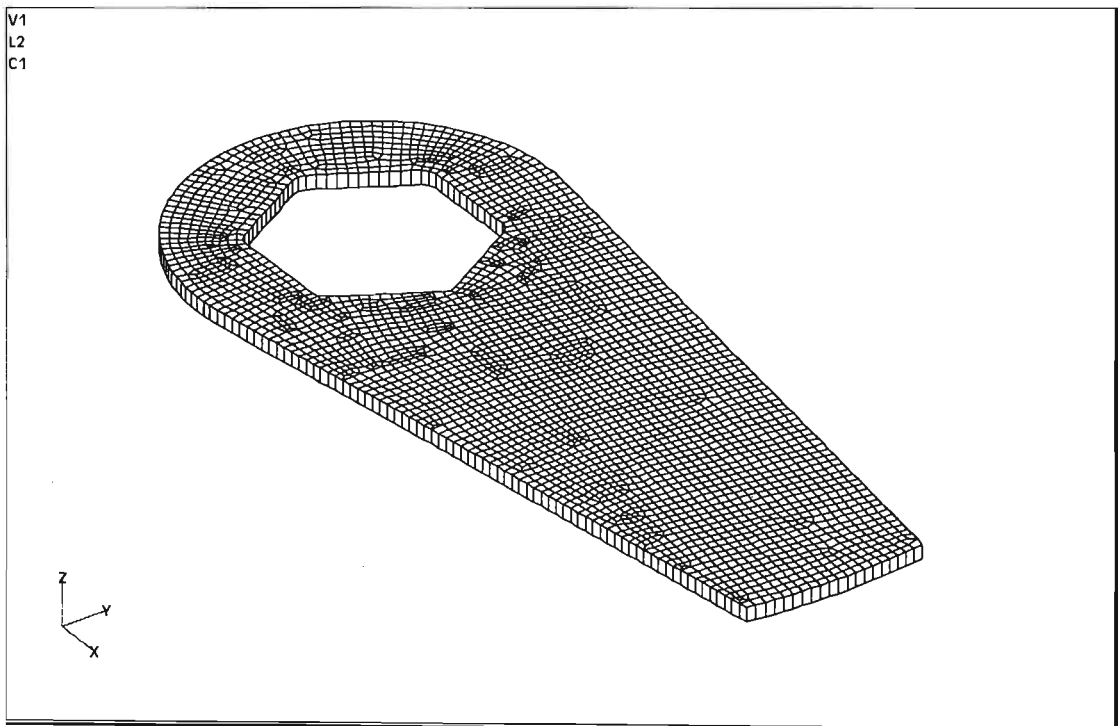


Figure: New Blade FEM mesh (Isometric view).

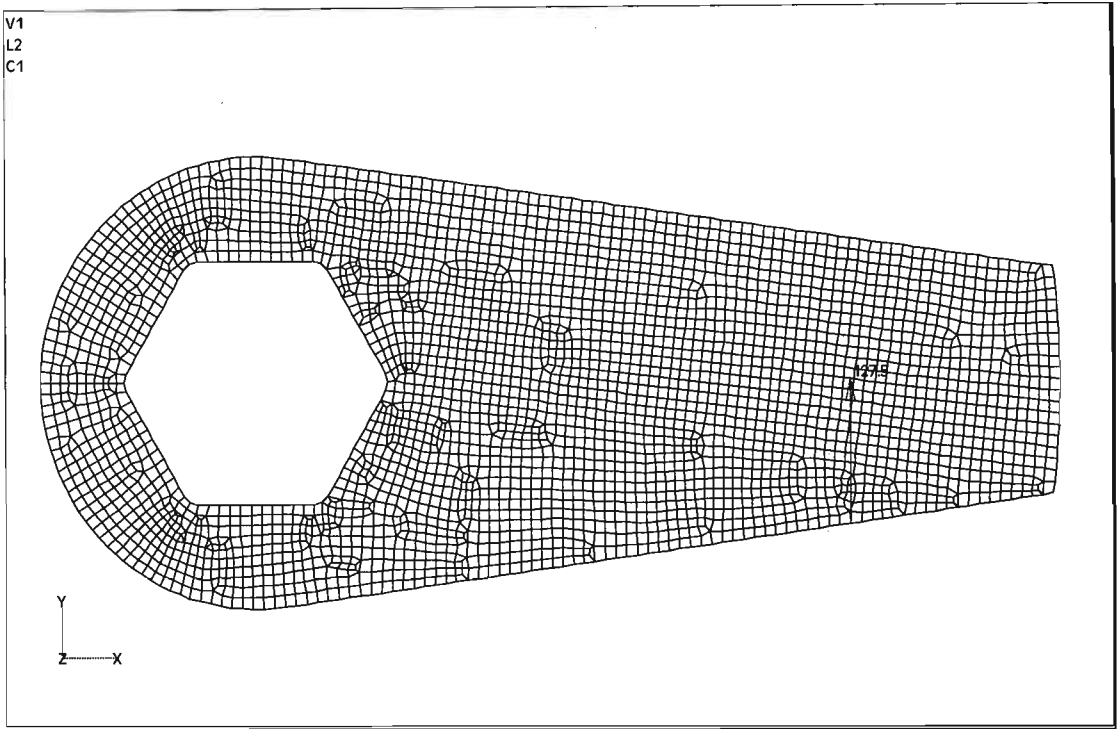


Figure: New blade Point load 127.5 N @ 110 mm from the centre of rotation.

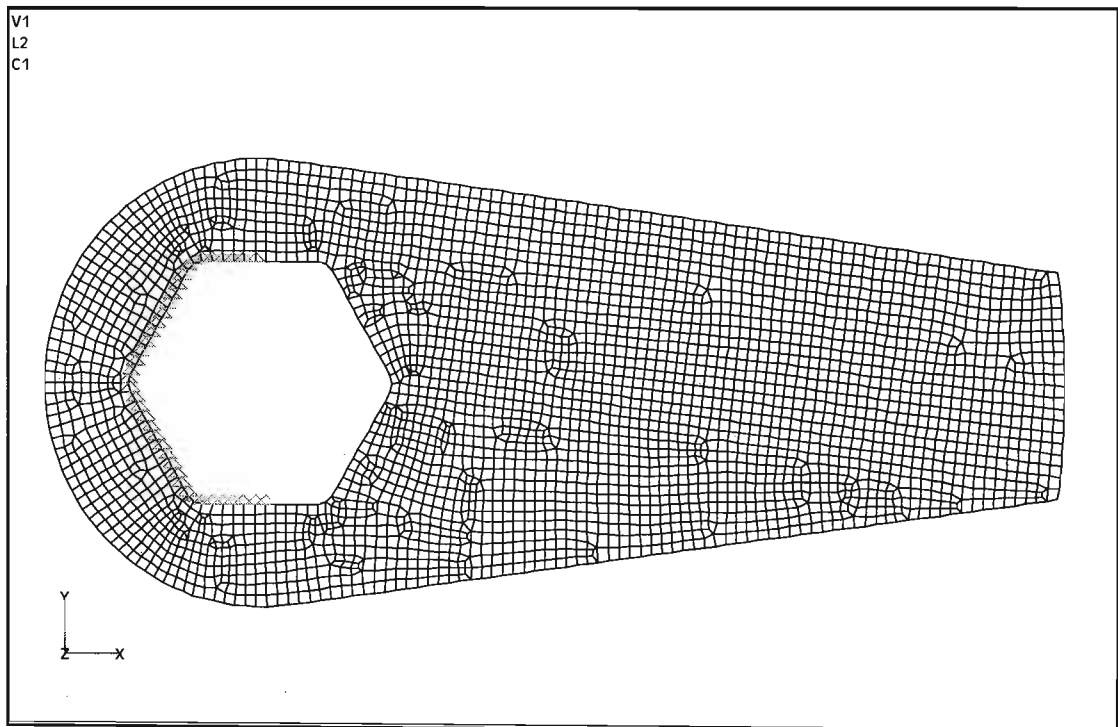


Figure: New blade Fully fixed nodes.

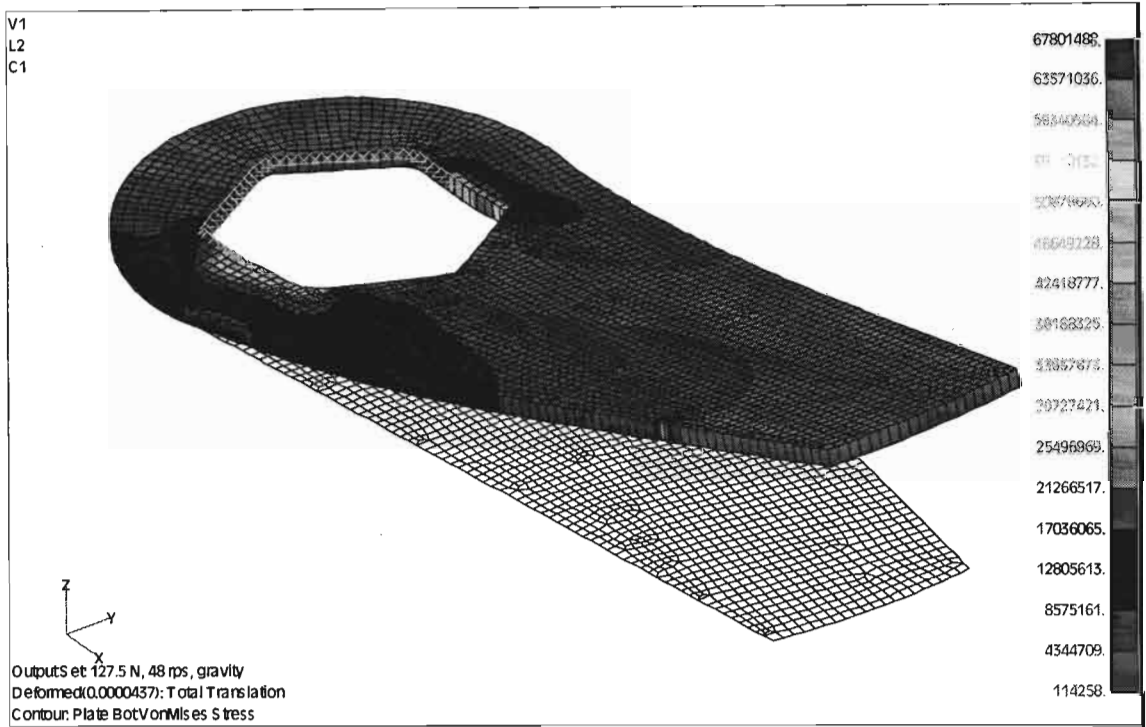


Figure: New blade Von Mises Stress Plot, Pa (Isometric view)

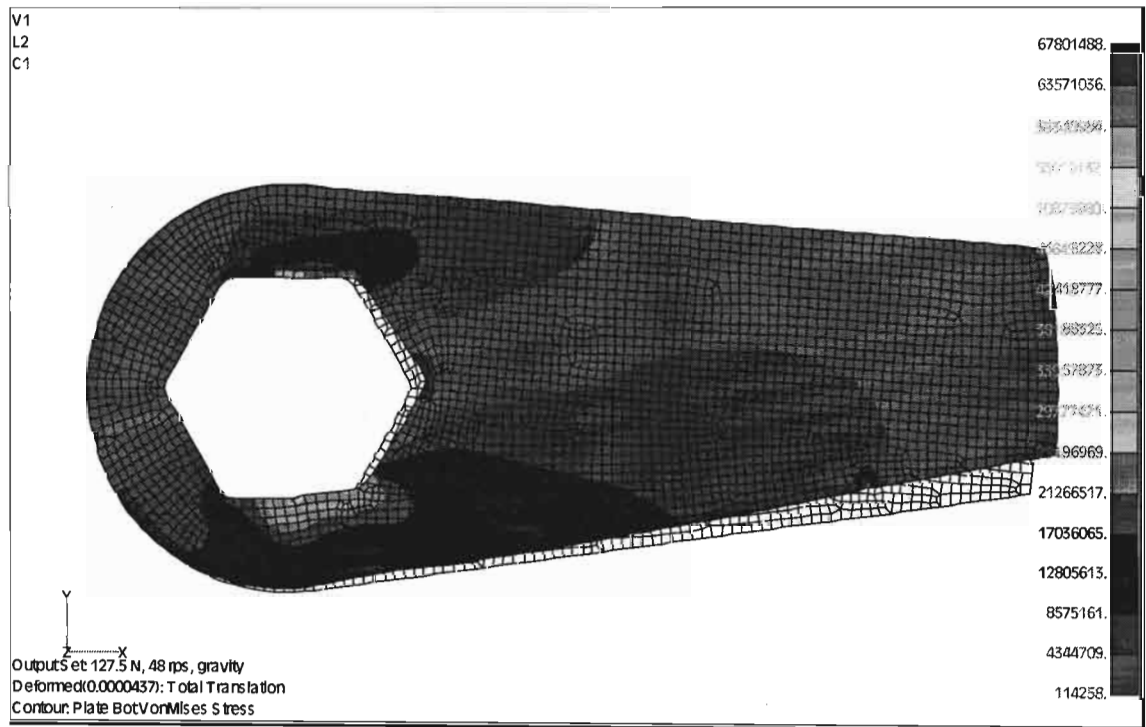


Figure: Von Mises Stress Plot, Pa. The deformed model is shown (XY view)

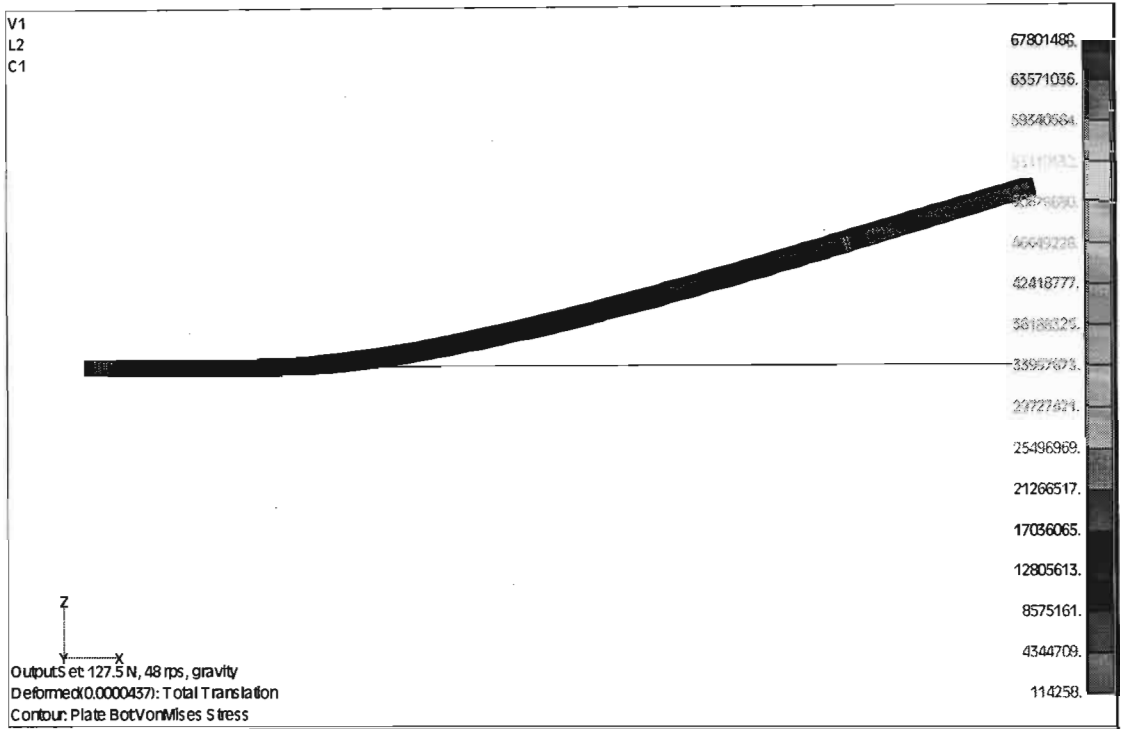


Figure: Von Mises Stress Plot, MPa. The deformed model is shown (ZX view)

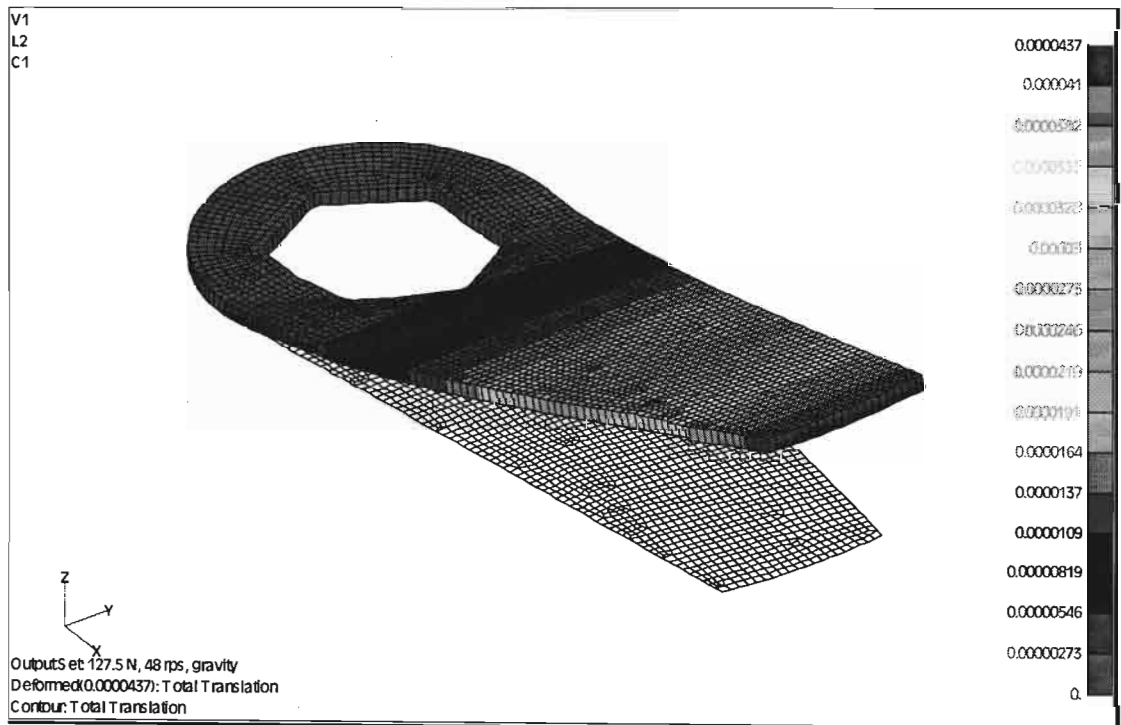


Figure: Total translation, mm (Isometric view)

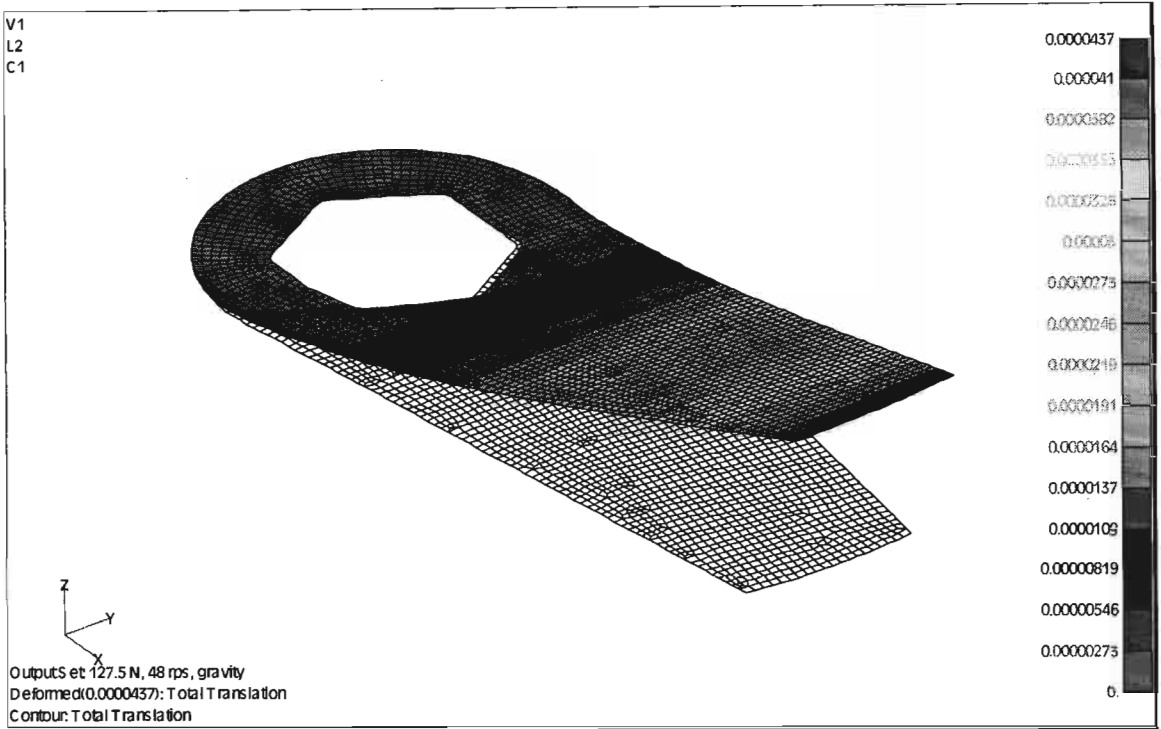


Figure: Total translation, mm. The deformed model is shown (XY view)

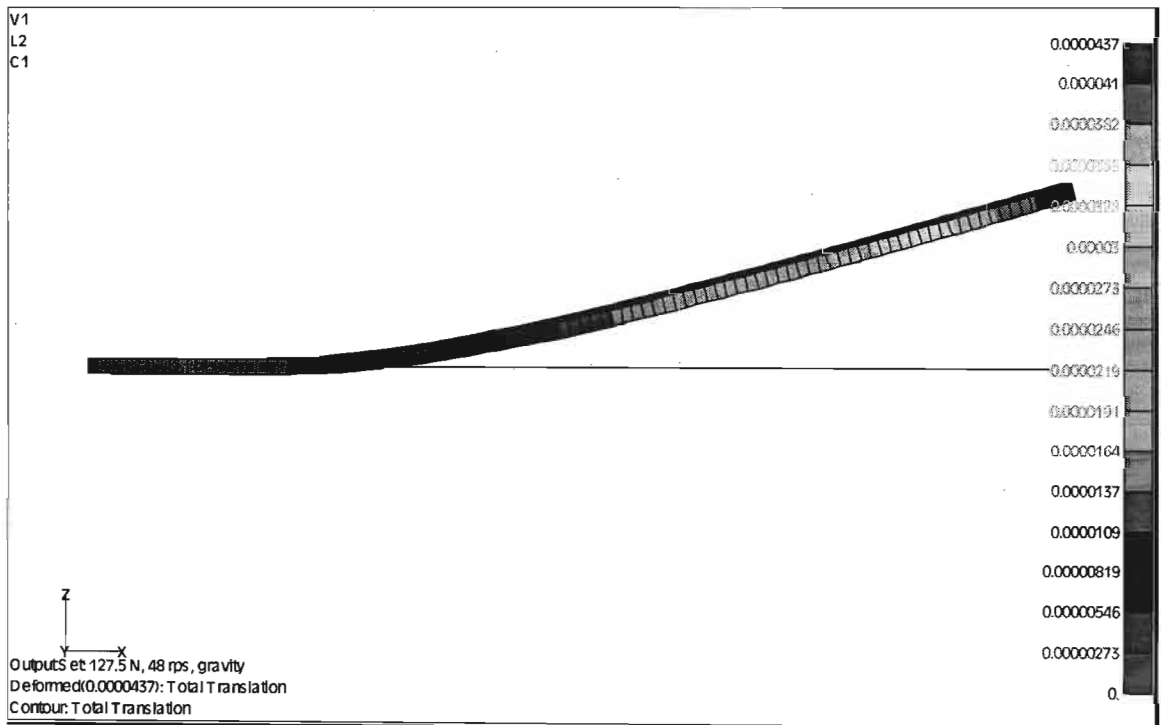


Figure: Total translation, mm. The deformed model is shown (ZX view)

APPENDIX G: MACHINE DESIGN CALCULATIONS

Belt calculation (example of 1 off 4 such calculations)

Poly-V Belt Drive Specification for wet-mill:

- Motor power $P = 11\text{kW}$
- Speed $n = 1470\text{r/min}$
- Speed ratio 1:1
- Service category 2
- Duty cycle normal ± 10 hours per day
- Approximate centre distance 750mm
- Service factor $S = 1.2$
- Design power $P_c = S \times P = 13.2\text{kW}$
- Belt section selected PK

Effective diameter of pulleys $d_{\text{eff}} = 160\text{mm}$

Pitch diameter of pulleys $d_p = 163.2\text{mm}$

$$\text{Belt speed } v = \frac{\pi \times d_p \times n}{60\,000} = \frac{\pi \times 163.2 \times 1470}{60\,000} = 12.56\text{m/s} < 55\text{m/s}$$

$$\text{Effective length of belt } L = 2E + \{\pi \times d_{\text{eff}}\} = 2 \times 750 + \{\pi \times 160\} = 2002.65\text{mm}$$

Nearest standard belt length $L = 1980\text{mm}$

$$\text{New centre distance } E = \frac{L - (\pi \times d_{\text{eff}})}{2} = \frac{1980 - (\pi \times 160)}{2} = 738.7\text{mm}$$

Basic power rating per rib BPR = 1.767kW

$$\text{Number of ribs } N = \frac{P_c}{BPR} = \frac{13.2}{1.767} = 7.47 \rightarrow 8$$

Belt reference: 8 PK 1980

Belt tension:

Linear mass/unit length/rib $M = 0.02\text{kg/m/rib}$

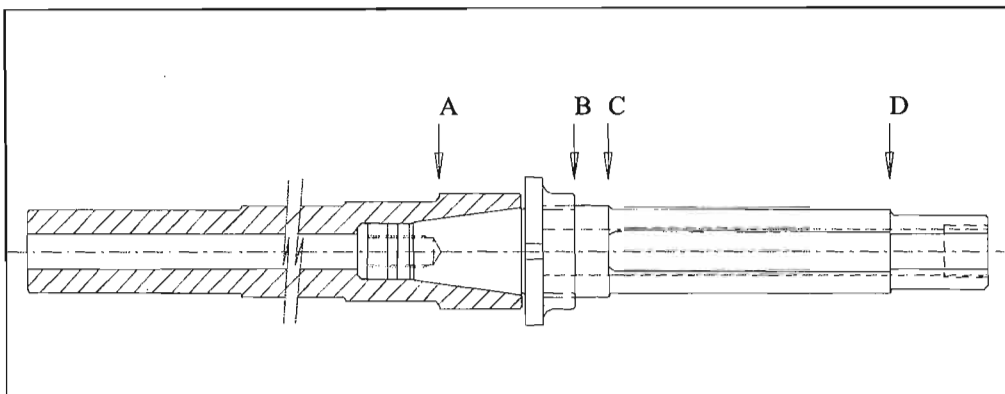
Static span tension T_{span}

$$T_{\text{span}} = \frac{500 \times P_c}{v} + (M \times \text{rib} \times v^2) = \frac{500 \times 13.2}{12.56} + (0.02 \times 8 \times 12.56^2) = 550.7\text{N}$$

Static shaft tension $T_{\text{shaft}} = 2 \times T_{\text{span}} = 1101.5\text{N}$

Load on bearings $F_p = 0.8 \times T_{\text{shaft}} = 881.2\text{N}$

Critical Section B (example of 1 off 4 such calculations)



Drawing: Critical sections of cutter mandrill and shaft

Bending moment at B (see diagram above):

$$\begin{aligned} M_b &= (220 \times 49) + (220 \times 106) + (220 \times 163) + (220 \times 220) \\ &= 10780 + 23320 + 35860 + 48400 \\ &= 118360\text{Nmm} \\ &= 118.4\text{Nm} \end{aligned}$$

Torsional moment at B:

$$\begin{aligned} M_t &= \frac{60W}{2\pi n} \times 2.8 \\ &= \frac{60 \times 9600 \times 2.8}{2\pi \times 1440} \\ &= 178.3 \text{ Nm} \end{aligned}$$

Stress concentration at B:

From tables, $K_t = 3.85$ & $q = 0.725$

$$\begin{aligned} K_f &= 1 + (K_t - 1)q \\ &= 1 + (3.85 - 1)0.725 \\ &= 3 \end{aligned}$$

$$K_{fs} = 0.75 \times K_f = 2.25$$

The cutter mandrill will experience the following torsional (τ_m) and bending (σ_b) stresses at the root of the threads at section B.

$$\text{Steady torsional stress: } \tau_m = \sigma_m = \frac{M_t r}{J} K_{fs}$$

Where $M_t = \text{max torque} = 178.3 \text{ Nm}$ (from above)

$r = \text{distance to outermost surface} = 26 \text{ mm}$

$J = \text{polar moment of inertia}$

$$\begin{aligned} J &= \frac{\pi}{32} (D^4 - d^4) \\ &= \frac{\pi}{32} (52^4 - 28^4) \\ &= 657473 \text{ mm}^4 \end{aligned}$$

$K_{fs} = 2.25$ from above

$$\therefore \tau_m = \sigma_m = \frac{178.3 \times 10^6 \times 26 \times 2.25}{657473} = 15.5 \text{ MPa}$$

Bending stress due to the blade loading: $\sigma_b = \sigma_a = \frac{My}{I}$

Where M = bending moment at B = 118.4 Nm (from above)

r = distance to outermost surface = 26 mm

I = moment of inertia

$$\begin{aligned} J &= \frac{\pi}{64}(D^4 - d^4) \\ &= \frac{\pi}{32}(52^4 - 28^4) \\ &= 328736 \text{mm}^4 \end{aligned}$$

$K_f = 3$ (from above)

$$\therefore \sigma_b = \sigma_a = \frac{118.4 \times 10^3 \times 26 \times 3}{328736} = 28 \text{MPa}$$

Fluctuating bending stress due to the blade loading (from the Goodman equation):

$$S_a = \frac{\sigma_a}{1 - \frac{\sigma_m}{S_u}}$$

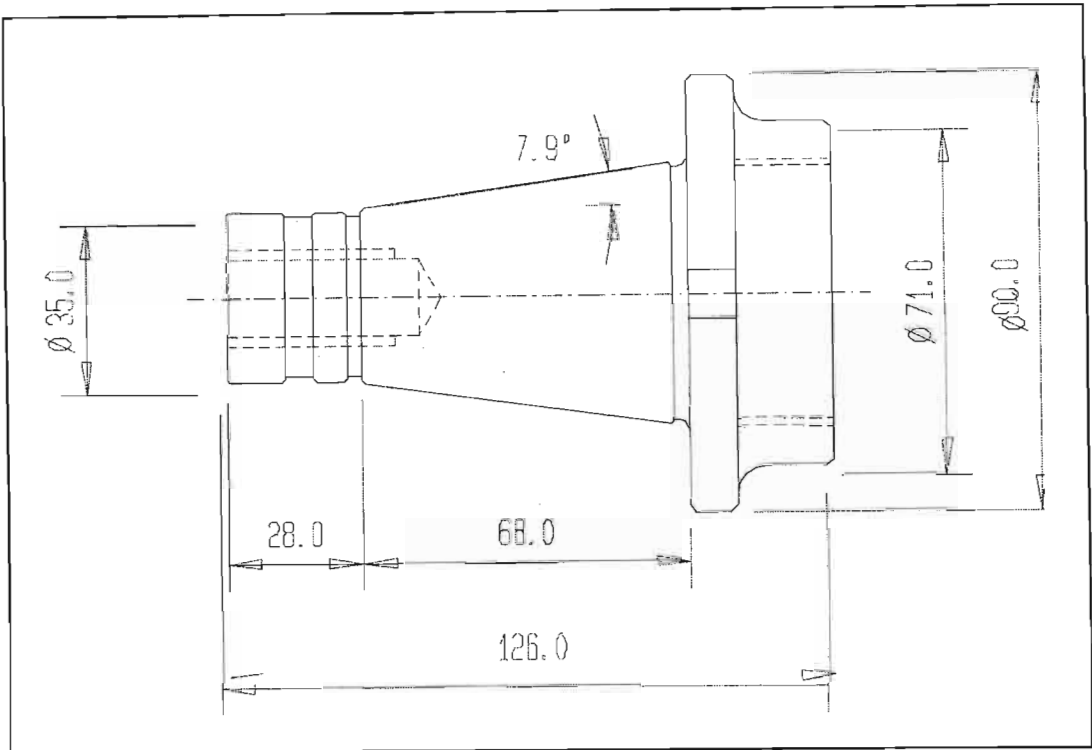
$$S_a = \frac{28.1}{1 - \frac{15.5}{500}} = \frac{28.1}{0.969} = 29 \text{MPa}$$

APPENDIX H: ENGINEERING DRAWINGS

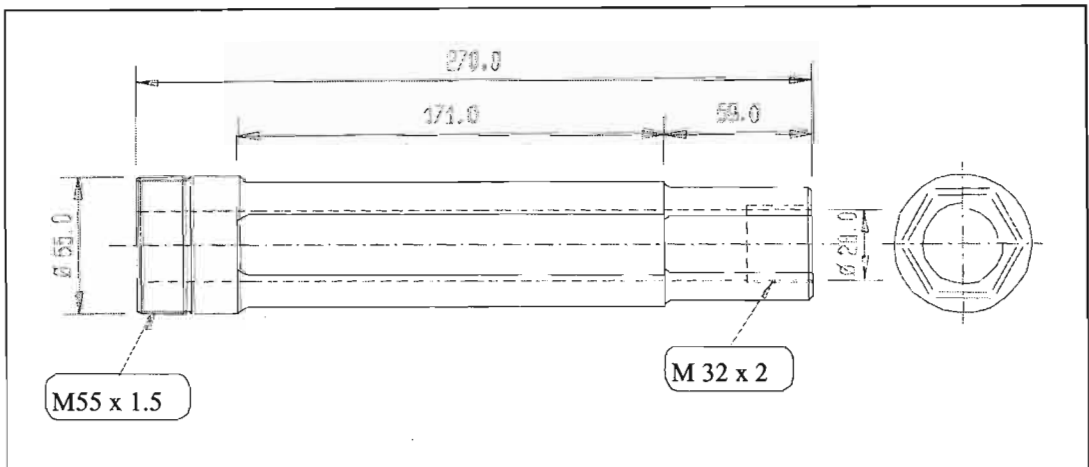
The drawing shows a vertical assembly of a cutter shaft. At the top is a pulley (4) on a shaft (2). Below the pulley is a top bearing (3) and a top shaft casing (11). The main shaft (12) passes through a main shaft casing (10) and a flange (9). At the bottom, there is a lower bearing (13) and a base nut (14). A shaft cap (8) is positioned above the lower bearing. Six blades (7) are attached to the main shaft. Washers (15) are used to secure the blades. A base shaft casing (5) is located at the very bottom of the assembly.

Item Number	Title	Quantity
1	Bottom nut	1
2	Base Shaft	1
3	Top Bearing	1
4	Belt Pulley	1
5	Base shaft casing	1
6	Hexagonal shaft	1
7	Blade	6
8	Shaft Cap	1
9	Flange	1
10	Main Shaft Casing	1
11	Top shaft casing	1
12	Main Shaft	1
13	Lower Bearing	1
14	Base Nut	1
15	Washer	6

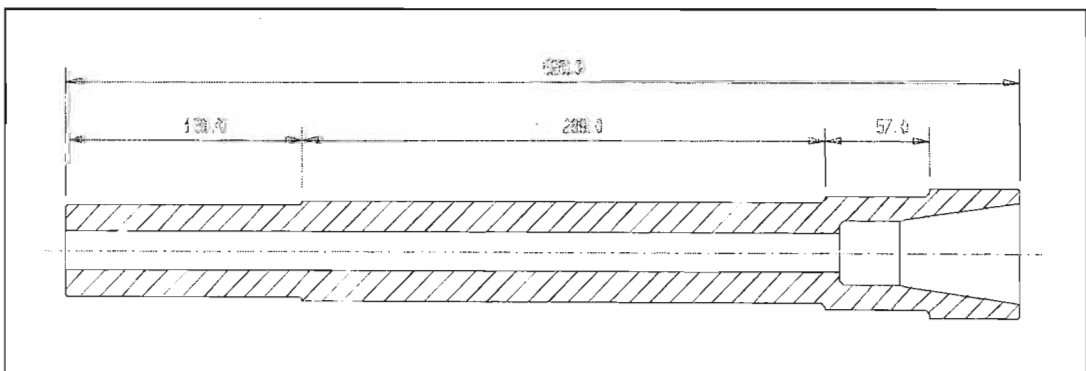
Drawing: Original bowl cutter shaft design



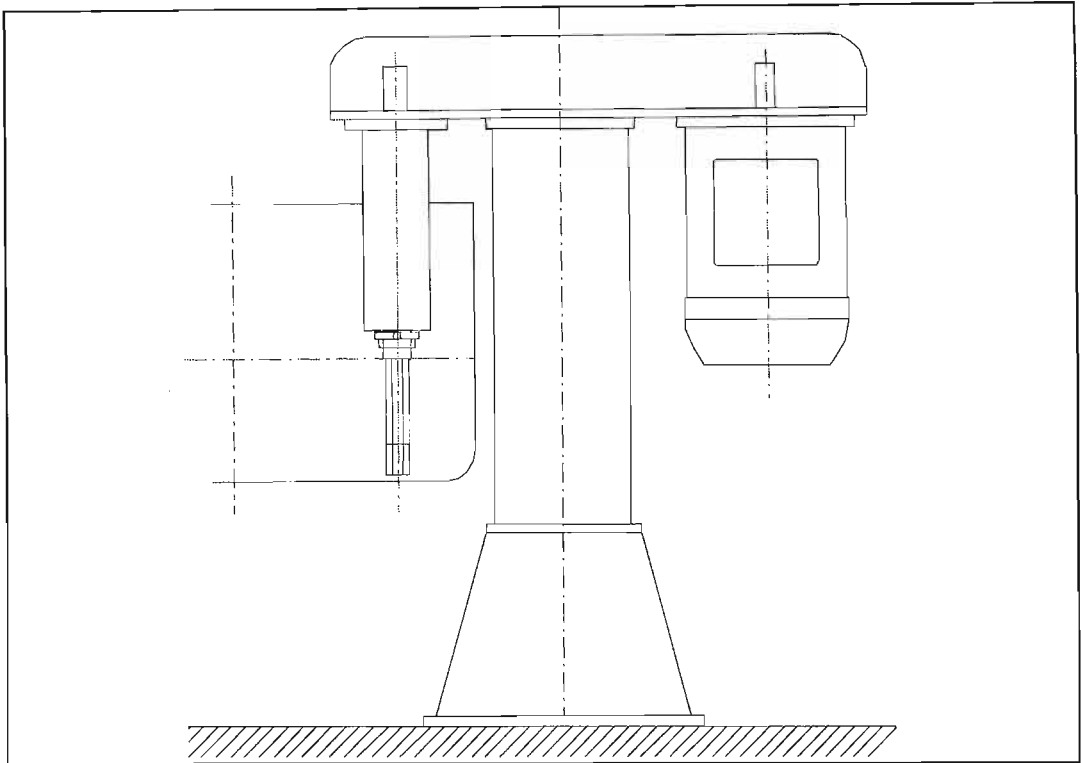
Drawing: Arbor for cutter mandrill, DIN standard 2080



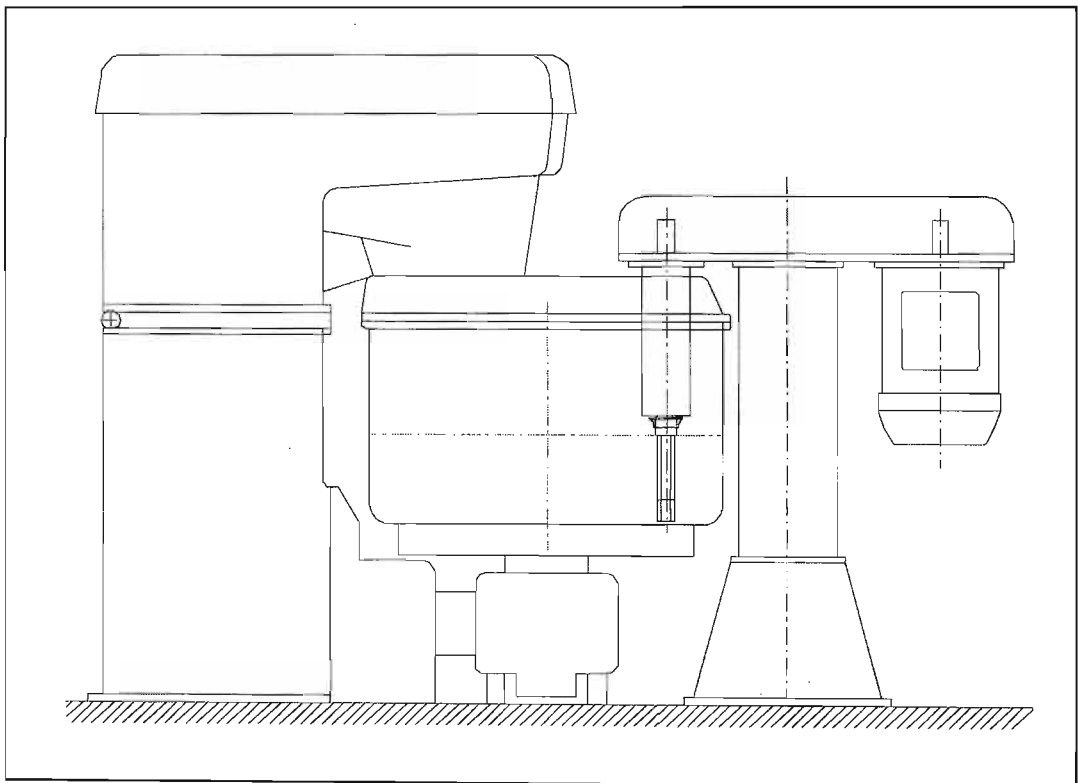
Drawing: Cutter mandrill



Drawing: Wet-mill cutter shaft



Drawing: Wet-mill cutter



Drawing: Assembly of wet-mill cutter and Diosna mixer.

APPENDIX I: HACCP & HAZOP

Background of HACCP

The HACCP process was developed in the 1960s. The Pillsbury Corporation developed the HACCP control system with NASA to ensure food safety for the first manned space missions.

The HACCP system and guidelines for its application were defined by the Codex Alimentarius Commission in the Codex Alimentarius Code of Practice. This Commission implements the Joint Food and Agriculture Organisation (FAO) of the United Nations and World Health Organisation (WHO) Food Standards Programme.

In the UK, the Pennington Report recommended that HACCP be adopted by all food businesses to ensure food safety. HACCP principles have subsequently been incorporated into specific UK regulations, including those for the meat and seafood industries. The British Retail Consortium Technical Standard for Companies Supplying Retailer Branded Food Products, for instance, requires the adoption of HACCP.

In the USA, many of its principles already are in place in the FDA-regulated low-acid canned food industry. FDA also established HACCP for the seafood industry in a final rule December 18, 1995 and for the juice industry in a final rule released January 19, 2001. In 1998, the U.S. Department of Agriculture established HACCP for meat and poultry processing plants, as well. (USDA regulates meat and poultry; FDA all other foods.) The FDA is now (2003) considering developing regulations that would establish HACCP as the food safety standard throughout other areas of the food industry, including both domestic and imported food products.

In SA, HACCP is not legally enforced; however, there is a burden of proof on manufacturers in respect of defence of defective product. Many large food manufactures have implemented HACCP as a part of GMP (good manufacturing practices).

HAZOP Definitions

Deviation

the keyword combination being applied (e.g. Flow/No).

Typical Primary keywords might be as follows. The list below is purely illustrative, as the words employed in a review will depend upon the plant being studied.

Primary - Hazard	Primary - Operation
Flow	Start-up
Temperature	Isolate
Mix	Maintain
Level	Inspect
	Drain
	Shutdown

Remembering that the technique is called Hazard & *Operability* Studies, operational words such as 'maintain' are also included. This type of Primary Keyword is often either overlooked or given secondary importance. This can result in the plant operator having, for example, to devise impromptu and sometimes hazardous means of taking a non-essential item of equipment off-line for running repairs because no secure means of isolation has been provided, or, even worse, it may be discovered that it is necessary to shut down the entire plant just to re-calibrate or replace a pressure gauge

Secondary Keywords, when applied in conjunction with a Primary Keyword, suggest potential deviations or problems. They tend to be a standard set as listed below:

Word	Meaning
No	The design intent does not occur (e.g. Flow/No), or the operational aspect is not achievable (Isolate/No)
Less	A quantitative decrease in the design intent occurs (e.g. Pressure/Less)
More	A quantitative increase in the design intent occurs (e.g. Temperature/More)
Reverse	The opposite of the design intent occurs (e.g. Flow/Reverse)
Also	The design intent is completely fulfilled, but in addition some other related activity occurs (e.g. Flow/Also indicating contamination in a product stream, or Level/Also meaning material in a tank or vessel which should not be there)
Other	The activity occurs, but not in the way intended (e.g. Flow/Other could indicate a leak or product flowing where it should not, or Composition/Other might suggest unexpected proportions in a feedstock)
Fluctuation	The design intention is achieved only part of the time (e.g. an air-lock in a pipeline might result in Flow/Fluctuation)
Early	Usually used when studying sequential operations, this would indicate that a step is started at the wrong time or done out of sequence
Late	As for Early

Cause

Potential causes which would result in the deviation occurring. (e.g. "Strainer S1 blockage due to impurities in Dosing Tank T1" might be a cause of Flow/No).

Consequence

the consequences which would arise, both from the effect of the deviation (e.g. "Loss of dosing results in incomplete separation in V1") and, if appropriate, from the cause itself (e.g. "Cavitation in Pump P1, with possible damage if prolonged").

Always be explicit in recording the consequences. These documents are used long after the people who have generated them are gone – they need to be written without the need for interpretation.

When assessing the consequences, one must look beyond protective systems or instruments which are already included in the design. For example a software alarm in the control room may or may not alert an operator. In the mean time pressure has been exceed / overflow occurred...

Safeguards

any existing protective devices which either prevent the cause or safeguard against the adverse consequences are recorded in this column. Safeguards need not be restricted to hardware... where appropriate, procedural aspects such as regular plant inspections may be included.

Action

where a credible cause results in a negative consequence, it must be decided whether some action should be taken. It is at this stage that consequences and associated safeguards are considered. If it is deemed that the protective measures are adequate, then no action need be taken, and words to that effect are recorded in the Action column.

Actions fall into two groups:

- Actions that remove the cause.
- Actions that mitigate or eliminate the consequences.

Whereas the former is to be preferred, it is not always possible, especially when dealing with equipment malfunction. However, always investigate removing the cause first, and only where necessary mitigate the consequences.

Two general comments to be borne in mind when formulating actions:

Do not automatically opt for an engineered solution, adding additional instrumentation, alarms, trips, etc. Not only might the capital cost be more than the costs of failure, but the reliability of such devices, and their potential for spurious operation may cause unnecessary plant down-time. In addition, the increased operational cost in terms of maintenance, regular calibration, etc. should also be considered (the lifetime cost of a simple instrument will be at least twice its purchase price... for more complex instrumentation this figure will be significantly greater). It is not unknown for an over-engineered solution to be less reliable than the original design because of inadequate testing and maintenance!

Take into account the level of training and experience of the personnel who will be operating the plant. Actions which call for elaborate and sophisticated protective systems are wasted, as well as being inherently dangerous, if operators do not, and never will, understand how they function. It is not unknown for such devices to be disabled, either deliberately or in error, because no one knows how to maintain or calibrate them.

HAZOP TEAM

The team who will conduct the Hazop study should consist of personnel with a good understanding of the process and plant to be reviewed. The participants should consist of people from a range of disciplines, and this aspect is one of the strengths of the Hazop methodology:

With a team of people, each with differing backgrounds and experience, potential problems are likely to be identified which would be missed by one or two people working on their own.

It is often the case that one person's solution can become a problem to another department within the project. These issues can be resolved amicably if both departments are represented.

The intention should be that questions raised during the meeting can be answered immediately, rather than having to resort to the time consuming process of referring to outside expertise.

HAZOP REPORT

The Hazop Report is compiled as soon as possible after the end of the study, and once completed does not change. It is a key document pertaining to the safety of the plant. The number of man-hours spent on the study is usually considerable. It is crucial that the benefit of this expert study is easily accessible and comprehensible for future reference in case the need arises to alter the plant or its operating conditions.

The report would include items such as:

- An outline of the terms of reference and scope of the study.
- A very brief description of the process which was studied.
- The procedures and protocol employed as well as the Keyword combinations applied.
- Results. This usually states the number of recommended actions.
- Master copies of the drawings studied.
- Copies of technical data used

APPENDIX J: PATENT 95/7249 EXTRACT

01/09 03 MON 09:50 FAX 0315661326

ADAMS AND ADAMS

002

REPUBLIC OF SOUTH AFRICA
 PATENTS ACT, 1978
 APPLICATION FOR A PATENT AND
 ACKNOWLEDGEMENT OF RECEIPT
 (Section 30(1) Regulation 22)

FORM P.1
 (to be lodged in duplicate)

THE GRANT OF A PATENT IS HEREBY REQUESTED BY THE UNDERMENTIONED APPLICANT ON THE BASIS OF THE PRESENT APPLICATION FILED IN DUPLICATE

PATENT APPLICATION NO.:	
21/01	95/7249
71 FULL NAME(S) OF APPLICANT(S)	

A & A REF: 12102

MICHAEL FREDERICK SMITH

ADDRESS(ES) OF APPLICANT(S)

332 CATO ROAD, GLENWOOD, DURBAN, 4001,
 REPUBLIC OF SOUTH AFRICA

54 TITLE OF INVENTION

"A METHOD OF MAKING BREAD"

Only the items marked with an "X" in the blocks below are applicable.

- THE APPLICANT CLAIMS PRIORITY AS SET OUT ON THE ACCOMPANYING FORM P.2. The earliest priority claimed is Country: Z. A. No: 94/6885 Date: 7/9/1994
- THE APPLICATION IS FOR A PATENT OF ADDITION TO PATENT APPLICATION NO. [21/01]
- THIS APPLICATION IS A FRESH APPLICATION IN TERMS OF SECTION 37 AND BASED ON APPLICATION NO. [21/01]

THIS APPLICATION IS ACCOMPANIED BY:

- A single copy of a provisional or two copies of a complete specification of 12 pages, Drawings of sheets.
- Publication particulars and abstract (Form P.8 in duplicate) (for complete only).
- A copy of Figure of the drawings (if any) for the abstract (for complete only).
- An assignment of invention.
- Certified priority document(s) (State quantity):
- Translation of the priority document(s).
- An assignment of priority rights.
- A copy of Form P.2 and the specification of RSA Patent Application No. [21/01] 94/6885 FILED ON 7/9/94
- A Form P.2 in duplicate.
- A declaration and power of attorney on Form P.3.
- Request for ante-dating on Form P.4
- Request for classification on Form P.9.
- Request for delay of acceptance on Form P.4.
- Copy of Form P.1

74 ADDRESS FOR SERVICE: Adams & Adams, Pretoria

DATED THIS 28th DAY OF AUGUST

19 95.

M. ROTTEVEEL
 ADAMS & ADAMS
 APPLICANTS PATENT ATTORNEYS

RECEIVED
OFFICIAL DATE STAMP
29. 08 95
REGISTRAR OF PATENTS

The duplicate will be returned to the applicant's address for service as proof of lodging but is not valid unless endorsed with official stamp.

BIBLIOGRAPHY

A C. Nielsen 2001 Bread- Total Majors Market Overviews, Performance Analysis & Competitive Analysis.

Adams J.F. Engstrom, A 2000 Dietary Intake of Whole Grain vs. Recommendations p75-78.

Adams T. The bakers of Paris and Bread Questions (Review) History Honour Society 2000 History. Retrieved January 2002 from www.findarticles.com

Baublis A J et al 2000 Antioxidants in Wheat based breakfast cereals CFW Feature p71-74.

Blanshard, J. M. V. Frazier, P.J. & Galliard, T.1986 Chemistry and Physics of Baking. Royal Society of Chemistry.

Blum Max. 1997 Food Fortification A key Strategy to end micronutrient malnutrition Nutrview 97 p1-16.

BOC Gases' Material safety data sheet no. 994-305: Liquid Nitrogen, Nov 1997

BOC Gases' Material safety data sheet no. 994-324: Carbon Dioxide, Nov 1997

Bodger, R Discussion and personal notes on fatigue analysis

Bognoli, Norris, Flynn, Timmerhause, Psychrometry, Evaporative Cooling, Refrigeration and Cryogenic processes, Chapter 12, Perry's Chemical Engineering Handbook. 6th Edition.

Boyson A 2001 Food Directorate FOD Act – Food legislation (012 312 0163)

Bread improvers, emulsifiers and preservatives, retrieved October 2000 from www.bakels.com

Bulk Conveying principles and practice pg12, 1996 Selenco Equipment manufacturers (Pty) Ltd

Cheng Ling-Min 1992 Food Machinery the production of cereal foods, snack foods and confectionery Ellis Horwood Ltd. UK

Clarke B.2000 The mysteries of Baking Bread Science on your doorstep.1-3 Retrieved July 2002 from www.ifm.bbsrc.ac.uk/public/foodinfosheets

- Cornell, Hugh J. Hoveling, Albert W. 1998 Wheat Chemistry and Utilisation Technomic Publishing Company, Inc.
- De Hook M 2001 Department of Health Nutrition Directorate US food Directorate, commissioned study. (021 312 0063)
- Diosna product sheet "spiral kneader – Diosna spiral kneading technique" 3/07/2002. From Diosna product manager: "Monte Rosenmeyer – (011) 8392950
- Diosna Spiral Kneader Technical pamphlet, 1977
- Fannie Merritt 1919 Bread and Bread Making Chapter IV 1-20 retrieved June 2002 from <http://aol.bartleby.com/87>
- Flour Advisory Bureau, London 1982 Approximate Composition of Flour used in bread making in the UK Nutritional Attributes of Flour and Bread Table 55.
- George Bathie 2000 Baking for profit, Starting a small Bakery ITDG Publishing UK
- Gere, J.M. & Timoshenko, S.P. 1994 Mechanics of Materials 3rd SI Edition, Chapman & Hall.
- Grant, Senior Technician, South African Bureau of Standards, Interview August 2003.
- Guidelines for acceptability Heart Foundation Approved products 2001
- Hallfrisch J et al 2000 Improvement in Insulin and Glucose Responses related to Grains. CFW Feature 66-69
- Hand-made bread retrieved from www.breadinfo.com p1-2
- Hironaka Y 2000 The History of the First Bread-maker in a One Cubic Foot Bakery plant C.F.W.Feature
- Incropera, F.P. & De Witt, D.P. 1990 Fundamentals of Heat and Mass Transfer 3rd Edition, John Wiley & Sons.
- Jacobs, D et al 2000 Defining the Impact of Whole-grain intake on chronic disease. CFW Feature 51-53
- Juvinall, Robert C., Fundamentals of machine component design. 2nd edition 1991 p3-p13
- Kamel, B.S. & Stauffer 1993, Advances in Baking Technology C.E.VCH Publishers.

- Kent, Jones and Amos, Modern Cereal Chemistry, 1981
- Kent, N.L. & Evers, A.D. 1994 Kent's Technology of Cereals. Elsevier Science. Ltd.
- Labadarios D. 1999 National Food Consumption Survey in Children Aged 1-9: SA NFCS-1
- Langenhoven M.L. Kruger M et al 1991 Food Composition tables 3rd Edition Parow National research Programme for Nutritional Intervention, Medical Research Council.
- M. F. Smith, Bread Patent No 95/7249
- Matz Samuel 1989 Equipment for Bakers Elsevier Science Publishers.
- May, J.B. 1987 Wet-milling: Process and Products. American Association of Cereal Chemistry, St Paul, MN, USA
- McCraw, Thomas K. 1997 Creating Modern Capitalism Harvard University Press
- Miller H.E. et al 2000 Whole Grain Products and Antioxidants CFW Feature 59-63
- Monte, technical manager at Rosenmeyer (suppliers of baking equipment including Diosna mixers) interviews October 2000 and July 2002.
- Mounder E. (interview with) 2001 UND Diet KZN Task force (033 260 5428).
- Olney R The symbol of Sustenance 1980 Time life Books Introduction
- Paul and Southgate 1978 Nutrient Composition of bread in the UK Technology of Cereals Table 58
- Perry's Chemical engineering Handbook, 6th Edition, Chapter 7 pg 27-29.
- Planet Wheat A short History of Bread 1-2 retrieved in January from www.cyberspaceag.com/breadhistory.html
- Ranhotra, S. Gur 1999 Nutritional Quality of Cereals and Cereal Based Foods Lorenz, K.J. & Kulp, K 1999 Handbook of Cereal Science and Technology 845-861
- Reiser Jackie, Marketing Manager Unilever, Interview November 2001
- Render Henry, Technical Manager Buhler Milling division, Interview July 2002
- Robertson H 2001 Head of Vitamin information Roche. (011) 3934794

- Ross Ryan N. The history of Bread Making retrieved from Encarta Online Encyclopaedia 2002. 3rd July 2002. <http://encarta.msn.com>
- S.A. Department of Health 1998 Nutritional health Claims-Guidelines Government working document 21-47
- S.A. Department of Health 2000 Fortification Profile for Maize Meals Wheat Flour (Draft)
- SA 1993 General nutrition Guidelines Ref 2034/1993 1225 Annex 3 Ref SA Medical research Council Food Composition Tables Cereals and cereal products.
- Sandstedt, R.M.1946 Cereal Chemistry pg 337
- Scale-ice machines: <http://www.hubbard.co.uk/icesystems/news/pr0017.htm>, retrieved 20 December 2002.
- Scale-ice machines: <http://www.marketsalescompany.com/toc.htm> retrieved 20 December 2002
- Scale-ice machines: <http://www.scotsman-ice.it/ing/scale.html> retrieved 20 December 2002
- Slavin,J. et al 2000 Consumption of Whole Grain Foods and decreased Risk of Cancer Proposed Mechanisms CFW Feature 54-58
- South Africa. Department of Labour. 1998 Occupational Health & Safety Act Legislation Service issue 14.
- South African Sugar Association 2000 Food Based Dietary Guidelines Information for Health Professionals.1-7
- Specialist Protein Products 2001The Age of Functional Foods Soy, Nutrition & Health 34-55
- SWEDEX SSL product data sheet, 24/11/1999. Re-approved 23 July 2002.
- Taylor, J.R.N. et el. (eds.) 1993 Cereal Science and Technology Impact on a changing Africa, Selected papers from the ICC international symposium, The CSIR.
- The history of bread P1-8 retrieved in December 2001 from www.bakersfederation.org.uk.
- Ullman, David G .The mechanical design Process, 1992, pg xii, Chapters 6 through 14

Van de Oever C, 29//2000 SGS South Africa Laboratory Test report Ref.No 00/04736

Voster E. 2001 University of Potchestroom Nutrition & Dietetics Fibre- particle size and its affect on the bodies functioning.

Whole grain bread. Sainsbury's Wholemeal Bread. UK Product Comparison 2001