

A Cross-linguistic Analysis of Finite Raising

Constructions

by

Feyisayo Fehintola Ademola-Adeoye

Submitted to the Faculty of Humanities, Development and Social Sciences in

fulfilment of the requirement for the degree of:

Doctor of Philosophy

in the

Department of Linguistics

at the

University of KwaZulu-Natal

Supervisor: Professor Jochen Zeller

Date submitted:

DECLARATION

I, the undersigned, hereby declare that:

A cross-linguistic analysis of finite raising constructions is my own work both in conception and execution. I declare that all the sources used have been indicated by means of complete reference, and also that I am responsible for the ideas expressed and examples given in this study.

.....

Feyisayo Fehintola Ademola-Adeoye

ACKNOWLEDGEMENTS

I would like to express my profound gratitude to everyone who has made my graduate studies possible and worthwhile.

My deepest gratitude goes to my supervisor Jochen Zeller, without him this thesis would have never been written. The opportunity to work with such an exceptional individual has been the most exciting intellectual challenge I have ever had. I thank him for helping me grow as a linguist and as a person; patiently and selflessly taking me through the ‚art‘ of being a syntactician.

I am also deeply grateful to Segun Awonusi, Duro Oni, Ayodeji Olukoju and Tope Omoniyi for their contribution towards making my graduate studies ambition a reality. Duro Oni, Ayodeji Olukoju and Segun Awonusi facilitated the approval of my study leave at the University of Lagos. Duro Oni and Tope Omoniyi also assisted in accessing a number of resource materials that were germane to my research. I also thank the University of Lagos for granting a study leave with full pay. I am grateful to my teachers and colleagues from the University of Lagos: Agwonorobo Eruvbetine, Karen Aribisala, Akachi Ezeigbo, Adeyemi Daramola, Oko Okoro, Hope Eghagha, Chimdi Madwagwu, Sola Osoba, Patrick Oloko, Abiodun Adeniji, Chris Anyokwu, Austin Nwagbara, Bose Afolayan, Moji Shodipe, Felicia Ohwovoriola, Tunde Opebi, Deji Medubi, Dele Orimogunje and Ayo Yusuf.

I would also like to thank teachers and colleagues in the department of linguistics UKZN, Heike Tappe, Kerry Jones, Jacqueline Carlyle, Ashley Lewis, Wim Low, Julia Sutherland, Megan Ball, Sonja Gammage and Estelle Van Der Merwe. I am especially grateful to Langa Khumalo for his friendship and kindness to me and for reading part of this work. I'd like also to thank the UKZN for a doctorate grant and the travel grant that enabled me to attend the 2010 AIASA Conference in Botswana.

To friends and family, people who ‚stood in the gap‘ for me all the years I have been away from home I owe a great personal debt, especially to Tokunbo and Funmi Johnson, Yewande Ntekim-Rex, Dayo Adedun, Adiza Otegbeye, Chris Fadipe, Akin

Akintunde, Olanma James, Ezekiel Togbe, Tonia and Biodun Daramola, Funmi and Femi Ashiwaju, Toyin and Fola Odufuwa, Mosun Shonibare, Ayo and Tunde Abel.

I am also grateful to the department administrators Esme Billiet and Bev for all their support and assistance in the five long years. While in Durban, many Nigerians and non-Nigerians opened their homes to me which meant the world to me as a foreign student. Many thanks to Segun and Busayo Ige, Peter and Angela Skevington, Tope Sokoya, Tope and Dare Sokoya, Becky and Tayo Oyerinde, Bunmi and Goke Akintola, Jumoke and Tunde Ogunsanya, Bunmi and Peter Odedina and Pius Owolawi who often had me as a guest on the shortest notice. I especially thank Pius for giving me the room of his spacious apartment when my family came to visit.

A special thanks to Tope Oni and friends like Gbolahan Aiyetoro and Nurudeen Ajayi who do so many things many times and to Seema Maharaj and Jayce Naiker of the UKZN interlibrary loan section for working tirelessly to meet my ‚endless‘ requests for interlibrary loans.

Without friends, graduate school would have been monotonous. I would like to thank all my friends all over the world Candice and Innocent Davidson, Bolaji and Bayo Asolo, Funke and Akin Adeyemo, Titilola and Kajode Olatuyi, Korede and Gbenga Omoloja, Yetunde and Kunle Ajigbolamu. For their encouragement, prayers and friendship over the years, I would like to express my heartfelt gratitude to Wumi Akin-Otiko, Toyin Aderemi, Winnie Ogana, Victoria Thela, John Mugisa, Abiola Ayeni and Pat Onianwa.

I am also grateful to the people who provided some of the data that I used in this dissertation. Man Xu (Chinese) Kanji and Miko Yoshimura (Japanese) Alice and Lucien (Kurundi) Vimbai Chibango and Langa Khumalo (Shona and Ndebele) Janet and Rose Olupot (Kikuyu), Cyriaque Hakizimana (Kiruúndi) and Dimitris Papadakis (Greek).

My success in the PhD programme would have been impossible without the support of my family during my sojourn in South Africa. I thank my in-laws and my parents especially my mum and all my siblings and their spouses, Morayo and Sunny

Adeyemi Jones, Odunayo and Kayode Jacob, Ayo Oludemokun, Tunde and Ruth Oludemokun, Jide Oludemokun and Wande Oludemokun.

My deepest gratitude goes to my husband Demola and my children Bolu, David, Melody, Iyanu and Daniel for bearing with me through it all and helping to keep the whole thing in perspective.

Although I have named many people I have left out even more especially my non-academic friends. I want to thank them all here and I apologize to those who I should have mentioned but have not.

Last, but not least, I thank God the giver of life for everything and everyone he raised to help me in achieving my dream. To Him be the glory and honour and power forever and ever.

ABSTRACT

This thesis provides and discusses a comprehensive collection of empirical data that show that many languages of the world manifest long A-movement of the subjects of embedded finite clauses to the subject position (Hyperraising) or object position (Hyper-ECM) of the main clause. The main theoretical claim of the thesis is that all these instances of long A-movement leave behind resumptive pronouns and should therefore be analysed on a par with related Copy Raising and Copy ECM constructions. My thesis therefore demonstrates that resumption is not restricted to A-bar movement contexts, but is also attested in A-movement constructions. Instead of the various language-particular analyses previously proposed in the literature, the thesis focuses on those aspects of long A-movement that all respective constructions in the different languages have in common and therefore provides a unified cross-linguistic analysis of long A-movement constructions.

An important empirical generalisation, first noted by Ura (1994), which is empirically supported by the data discussed in this thesis, is that if a language has Hyperraising or Hyper-ECM, it is also a pro-drop language. On the basis of this generalisation, it is argued that Hyperraising and Hyper-ECM constructions involve the use of resumptive *pro* in the embedded subject position, while languages with Copy Raising and Copy ECM use overt pronouns. Apart from this difference, it is argued that these A-movement constructions are identical in all crucial respects.

Furthermore, it is claimed that agreement inside the embedded finite clauses from which long A-movement takes place is indicative of the ability of embedded T to license nominative case on the embedded subject. Hence, no deviation from standard Minimalist assumptions is required. It is suggested that the role of the resumptive subject pronoun is to receive the case assigned by the probing T-head inside the embedded clause. It is also argued that it is the existence of a resumptive pronoun which causes the coreferential subject DP to be without case, which in turn creates a context in which long A-movement of this DP becomes both necessary and possible.

This analysis is based on the idea that at first merge, the raised subject is merged with the null/overt resumptive pronoun in the embedded subject position to form one

complex constituent (which is known in the literature as a „big’ DP). While the pronoun remains in the embedded subject position to absorb the case in the embedded finite clause, the raised subject is attracted into the matrix subject position to absorb the case in the matrix clause.

CONTENTS

DECLARATION	ii
ACKNOWLEDGEMENTS	iii
ABSTRACT	vi
CONTENTS	viii
ABBREVIATIONS	x
INTRODUCTION	1
CHAPTER 1	13
Basic assumptions	13
1.1 Core Ideas of the Minimalist Program	13
1.2 Phases	20
1.3 The Standard Analysis of Raising in the MP	22
1.4 The Standard Analysis of ECM Constructions in the MP	26
1.5 Raising versus Control	32
1.6 Tests for Raising	35
1.7 Tests for ECM Constructions	37
CHAPTER 2	40
Long subject-to-subject raising	40
2.1 Hyperraising from finite subjunctive complements	41
2.1.1 Hyperraising in Greek	41
2.1.2 Hyperraising in Japanese	44
2.1.3 Hyperraising in Zulu	46
2.1.4 Hyperraising in Rumanian	50
2.1.5 Hyperraising in Persian	52
2.2 Hyperraising from finite indicative complements	56
2.2.1 Hyperraising in Bantu	56
2.2.2 Hyperraising in Turkish	65
2.2.3 Hyperraising in Brazilian Portuguese	68
2.2.4 Hyperraising in Kipsigis	70
2.2.5 Hyperraising in Bhojpuri	72
2.2.6 Hyper-Raising in Mandarin Chinese	73
2.2.7 Hyper-Raising in Dholuo	77
2.2.8 Hyper-Raising in Finnish	77
2.2.9 Hyper-Raising in Moroccan Arabic	78
2.2.10 Hyperraising in other languages	79
2.3 Copy Raising: Hyperraising with resumptive pronouns	81
2.3.1 Copy Raising in Haitian Creole	81
2.3.2 Copy Raising in Igbo	83
2.3.3 Copy Raising in Yoruba	85
2.3.4 Copy Raising in Hebrew	86
2.4 Arguments against a Copy Raising Analysis for English-type Languages ..	87
2.5 Conclusion	90
CHAPTER 3	92
Long subject-to-object raising	92
3.1 Hyper-ECM	92
3.1.1 Hyper-ECM in Balkan languages (Greek and Rumanian)	92
3.1.2 Hyper-ECM in Korean	97
3.1.3 Hyper-ECM in Japanese	102
3.1.4 Hyper-ECM in Turkish	107

3.1.5	Hyper-ECM in Herero	108
3.1.6	Hyper-ECM in Kipsigis	109
3.1.7	Hyper-ECM in Chamorro	112
3.1.8	Hyper-ECM in Fijian	116
3.1.9	Hyper-ECM in Dholuo	116
3.1.10	Hyper-ECM in other languages	117
3.2	On (the absence of) Copy ECM	119
3.3	Conclusion	121
CHAPTER 4		123
An overview of existing proposals		123
4.1	Raising is possible because the embedded T is defective	124
4.1.1	Lack of Tense	124
4.2	Case assignment	134
4.2.1	Case delay	134
4.2.2	Case assignment does not inactivate DP	139
4.3	The embedded clause as a Small Clause	140
4.4	Base Generation	143
4.5	Conclusion	146
CHAPTER 5		148
Long A-movement and resumption		148
5.1	Ura's generalisation	148
5.2	Hyper-Raising, Hyper-ECM and Copy Raising	154
5.3	Null resumptive pronouns in A-movement	157
5.3.1	Null resumptive pronouns	157
5.3.2	Resumption in A-movement constructions	160
5.4	Hyperraising and Hyper-ECM with full pronouns	162
5.5	Why resumption?	170
5.6	Conclusion	180
CHAPTER 6		181
The PIC and A-movement to [Spec, C]		181
6.1	The Phase Impenetrability Condition and movement to the edge	181
6.2	Successive-cyclic A-movement through [Spec, C]	186
6.3	Resumption, the EPP, and long A-movement	192
6.3.1	C and inflectional features	192
6.3.2	The operation Agree and the nature of uF	198
6.4	The analysis of long A-movement	210
6.4.1	„Big' DP and multiple Agree	210
6.4.2	A note on the EPP- and edge-features	219
6.5	Conclusion	222
CHAPTER 7		224
Conclusion		224
7.1	Summary of thesis	224
7.2	Suggested further research	228
REFERENCES		234

ABBREVIATIONS

ABS	absolute case
ACC	accusative case
AGR	agreement marker
ART	article
ASP	aspect marker
AUX	auxiliary
BP	basic (adjective) prefix
CAUS	causative
COP	copular
COMP	complementiser
CC	complement case
CL	clitic
DAT	dative
DC	default case
DECL	declarative
DEM	demonstrative
DUR	durative
ECM	exceptional case marking
EVID	evidential
EXPL	expletive
ERG	ergative
FEM	feminine
FOC	focus marker
FUT	future tense
FV	final vowel
GEN	genitive marker
HAB	habitual
HON	honorific
IND	indicative
INF	infinitive marker
IMPERF	imperfect
IRREAL	irrealis

LOC	locative
MASC	masculine
MP	minimalist programme
NEG	negative marker
NEUT	neuter
NOM	nominative
NONPAST	non past tense
OBJ	object
OBL	oblique case
OM	object marker
PASS	passive
PAST	past tense
PC	pronominal clitic
PERF	perfect tense
PERS	person
PL	plural
POSS	possessive marker
PR	predicative
PRES	present tense
PROG	progressive
PROP.ART	proper noun article
PRT	particle
PT.AT	atemporal participle
REC	reciprocal
REC.PST	recent past
REFL	reflexive
RC	relative concord
RPST	remote past tense
SBV	subjunctive verb
SC	subject concord
SG	singular
SM	subject marker
SUB	subject affix
SUBJ	subjunctive

SUPERL	superlative
ST	stative
TOP	topic
TNS	tense
VS	verb stem

INTRODUCTION

Raising has been a recurring concept in syntactic analysis and linguistic theory since it first appeared in the early works of Rosenbaum (1967), Chomsky (1973) and Postal (1974). Raising is a syntactic operation that causes certain types of matrix (main clause) verbs to trigger the movement of an NP/DP from the subject position of an embedded clause to the subject position of the main clause (cf. Postal, 1974: 284). Consider the following sentences:

- (1) a. It seems that he loves mashed potatoes.
b. He seems to love mashed potatoes.
c. *He seems that (he) loves mashed potatoes.

According to the standard treatment of Raising constructions in recent versions of Generative Grammar, such as the Minimalist Program (Chomsky, 1995, 2001, 2005), a finite clause has tense and agreement features that enable it to license nominative case on its subject. Therefore, the subject NP/DP *he* in the finite embedded clause in (1a) is assigned nominative case. Since there is no need for the embedded subject to move out of the subordinate clause, it remains *in situ*. Since the matrix verb *seems* does not select a thematic subject, a so-called expletive (a dummy, non-referential grammatical element, the pronoun *it*) is introduced as the subject of the matrix clause in order to satisfy the condition that all sentences must have subjects.¹

In contrast, the thematic subject *he* of the embedded non-finite clause in (1b) (a Raising infinitive) appears in the matrix subject position. In the Minimalist Program, Raising infinitives are assumed to be ‚defective‘, because they lack tense and agreement features associated with finite clauses.² Therefore, nominative case cannot be assigned inside a Raising infinitive. Because the pronoun *he* cannot get nominative case in the defective embedded clause, it is assigned nominative case via the tense and agreement features of

¹ This condition is the *Extended Projection Principle* (Chomsky, 1981, 1982). The EPP will be discussed in chapter 1, section 1.1 below.

² The notion of defectiveness is further explained in chapter 1, section 1.3.

the non-defective finite matrix clause. Consequently, *he* agrees with the matrix verb *seem*. Subsequently, *he* moves out of the complement clause to the subject position of the matrix clause in order to fulfill the requirement that all sentences must have subjects. This movement step is a further consequence of the fact that *he* agrees with the matrix verb and has been assigned nominative case from the matrix clause.

Importantly, according to standard assumptions about Raising constructions, movement of an embedded subject to the matrix subject position is only possible out of defective infinitives. Raising out of finite clauses, which have tense and agreement features and which are considered to be non-defective, is neither necessary nor permitted. This is illustrated by (1c). In (1c), the embedded pronominal subject *he* can be assigned nominative case by the finite complement clause, so there is no need for *he* to seek nominative case from outside its own clause. In addition, the embedded clause, being finite, does not permit the embedded *he* to move out. This explains why (1c) is ungrammatical.

Similar considerations apply to the analysis of constructions such as (2b), which is an example of an Exceptional Case Marking (ECM)-construction:

- (2) a. John believes that she is smart.
b. John believes her to be smart.
c. *John believes her that (she) is smart.

The clausal complement of the verb *believe* in (2a) is finite, and consequently, nominative case is available to the subject *she*. However, the infinitival complement of *believe* in (2b) is considered to be defective, and nominative case is not available. Instead, the embedded subject receives accusative case from the verb in the matrix clause; in some theories (Rosenbaum, 1967; Johnson, 1991; Koizumi, 1993, 1995; Radford, 2004; Hong, 2005; Runner, 2006), it is assumed that this "exceptional" case marking is accompanied by subsequent Raising of the embedded subject to the matrix *object* position, in analogy to subject-to-subject Raising in (1b). (2c) is assumed to be

ungrammatical for the same reasons that (1c) is: the subject of a finite embedded clause does not require exceptional case marking from outside, and furthermore, exceptional case marking into (and subject-to-object Raising from) a finite clause is not licensed.

Assuming for the moment that constructions such as (2b) do indeed involve movement to a matrix object position, both Raising and ECM-constructions involve A-movement from a defective clausal complement into the main clause. The ungrammaticality of (1c) and (2c) suggests that “long” A-movement (= movement of a DP from an embedded finite clause to an argument position in the main clause) is generally ruled out by the principles of grammar. However, contrary to the assumption that only embedded infinitives like those in (1b) and (2b) allow A-movement of their embedded subjects into the matrix clause, this thesis presents and examines empirical data from Bantu languages such as Kikuyu, Kirundi, Shona, Herero and Zulu (Perez, 1985; Kavari & Marten, 2005; Zeller, 2006a, b); Irish (McCloskey, 1984,1988); Rumanian (Grosu & Horvath, 1984; Rivero, 1991); Hebrew (Lappin, 1984); Haitian Creole (Deprez, 1992); Turkish (Moore, 1998; Aygen, 2004); Igbo (Ura, 1998); Greek (Joseph, 1976; Soame & Perlmutter, 1979; Alexiadou & Anagnostopoulou, 1999); Japanese (Kuno, 1976; Uchibori, 2000, 2001; Tanaka, 2002; Hoji, 2005); Brazilian Portuguese (Rodrigues, 2004); Yoruba (Adesola, 2005); Korean (Hong, 2005); and Persian (Darzi, 2008) that show that A-movement out of finite complement clauses is indeed possible in many languages. For example, Alexiadou and Anagnostopoulou (1999) and Uchibori (2000, 2001) show that in Greek and Japanese, some finite complement clauses allow their subjects to move to the matrix subject position:

- (3) Ta pedhia arxisan [na trexoun]
the children-NOM started-3PL SUBJ run-3PL
„The children started to run.’

(Greek; Alexiadou and Anagnostopoulou, 1999: 5)

- (4) John-ga [motto benkyoosu-ru-yooni] na-u/-ta
 John-NOM more study-NONPAST-SUBJ happen -NONPAST/PAST
 (lit.) ‚It has happened that John studies harder.’

(Japanese; Uchibori, 2000: 143)

The embedded verb of the Greek example in (3) is overtly marked for agreement, indicating that it is finite. Furthermore, the embedded clauses in the Greek example in (3) and the Japanese example in (4) are introduced by the complementisers *na* and *-yooni* respectively, which mark subjunctive mood. The presence of these complementisers indicates that the complement clauses are finite. Nevertheless, the embedded subject has undergone subject-to-subject Raising out of these embedded finite clauses, a process known in the literature as Hyperraising.

Similarly, Joseph (1976) and Hong (2005) provide extensive arguments for the existence of “Hyper-ECM”, i.e. Raising-to-object position of an embedded subject NP/DP from finite complements, in Greek and Korean respectively:

- (5) Θ eoro ton yani [pos ine eksipnos]
 consider-1SG ACC-John COMP be-3 SG smart
 ‚I consider John to be smart.’

(Greek; Joseph 1976: 241)

- (6) John-i Mary-lul [cengcikha-ess-tako] sayngkakha-n-ta
 John-NOM Mary-ACC honest- PAST-COMP think-PRES
 ‚John believes that Mary was honest’

(Korean; Hong, 2005: 59)

Both sentences in (5) and (6) have finite indicative complements with overt complementiser *pos* (Greek) and *tako* (Korean). In addition, the embedded T-head of the Greek example in (5) is inflected for agreement. The occurrence of overt complementisers and agreement therefore means that the embedded clauses in (5) and (6)

are finite clauses. However, the fact that the subjects of the embedded clauses, *ton Yani* and *Mary-lul*, in (5) and (6) appear in the accusative form is an indication that these embedded subjects are assigned accusative case by the matrix verb. That these accusative subjects of the embedded clauses appear before the overt complementisers *pos* and *tako* furthermore demonstrates that the embedded subjects have raised to the object position in the matrix clause.

Hyperraising and Hyper-ECM constructions obviously raise problems for the traditional theory of Raising which is based on considerations of case and NP/DP-movement. My thesis addresses these problems, and is guided by two main research objectives. First, it provides a comprehensive collection of empirical data that show which languages manifest A-movement out of finite clauses, and in what syntactic contexts. Second, my study also provides a theoretical discussion of the implications that the existence of long A-movement has for the traditional analysis of Raising presented in the Minimalist Program (Chomsky, 1995, 2001, 2005)

One way in which many of the existing analyses of long A-movement have approached the problem raised by the data in (3-6) is to re-define the notion of ‚defectiveness‘. If the Minimalist assumption is correct that NP/DPs move out of embedded clauses because defective complements cannot license nominative case on their subjects, then the examples in (3-6) cast doubt on the definition of defectiveness in terms of finiteness. It has therefore been argued that some other grammatical property of the embedded clauses in (3-6) must be responsible for their defective nature and the absence of case on the subjects (which, as was noted above, is considered a prerequisite for Raising). Many proposed explanations of the data in (3-6) (Alexiadou and Anagnostopoulou, 1999; Uchibori, 2000, 2001; Zeller, 2006a, b) have therefore maintained that Raising is related to the unavailability of nominative case and have tried to link this situation to other properties of finite clauses that could be interpreted as ‚symptoms‘ of defectiveness.

However, in my thesis, I want to put forward an alternative hypothesis. I suggest that Raising of a subject NP/DP is permitted in certain languages even though nominative

case has been assigned in the embedded clause. In other words, I interpret the data in (3-6) as evidence that the traditional Minimalist account of Raising that equates A-movement with the unavailability of nominative case is incorrect for the following reasons: In the MP (Chomsky, 2000, 2001) nominative case is assumed to be assigned under ϕ -feature agreement and CPs are typically analysed as strong phases (Chomsky, 2001, 2008); the presence of a CP prevents any constituent within the C-command domain of C from moving out of CP (a consequence of the Phase Impenetrability Condition PIC³). However, the embedded verb of the Greek examples in (3) and (5) are overtly marked for agreement, indicating that they are finite and nominative case is available for their subjects. Also, the embedded clauses in the Greek examples in (3) and (5) and the Japanese example in (4) and (6) are introduced by the complementisers *na* and *pos*; and *-yooni* and *-tako* respectively indicating that the complement clauses are finite CPs. Yet, the embedded subject has undergone subject-to-subject/subject-to-object Raising out of these embedded finite clauses.

What I suggest is that Raising of the embedded subject NP/DPs in the examples in (3-6) is required even though the finiteness of the embedded clauses in these examples makes the embedded subject position a case position. Importantly, however, even though I claim that nominative case is assigned in the embedded clauses in (3-6), I assume that it is not assigned to the subject NP/DP. Instead, I suggest that nominative case in the examples in (3-6) is assigned to a phonetically null *resumptive pronoun* which occupies the embedded subject positions in these Hyperraising and Hyper-ECM constructions. I propose that it is the presence of a resumptive pronoun which "absorbs" the nominative case available in finite clauses which leaves the thematic subject NP/DP caseless. As a consequence, the embedded thematic subject NP/DP must receive case from, and eventually move into a position in, the matrix clause.

As noted above, I argue that in the examples (3-6), the resumptive pronoun in the embedded clauses is *pro*, i.e. a subject pronoun without phonetic content. Consequently, in languages such as Greek or Japanese, the resumptive pronoun that occupies the

³ The PIC is discussed in more detail in chapter 1, section 1.2.

embedded subject position in long A-movement constructions is invisible. As I will show in this study, it is an interesting fact that Hyperraising and Hyper-ECM constructions are only attested in pro-drop languages, an observation that I label *Ura's generalization* (with reference to Ura 1994). However, as I show in more detail in the following chapters, languages such as Haitian Creole or Igbo use overt resumptive pronouns in long A-movement constructions:

- (7) Jan sanble [li pati]
 John seems he leaves
 ‚John seems he to have left.‘

(Haitian Creole; Deprez, 1992: 192)

- (8) Ézè di m [kà ọ hũ-rũ Adá]
 Eze seems to me COMP he see-ASP Ada
 ‚Eze seems to me that he saw Ada.‘

(Igbo; Ura, 1998: 68-69)

As the translation of (7) and (8) shows, the main clause verbs in these examples are the equivalents of the English Raising verb ‚seem‘. In (7) and (8), the embedded subject NP/DPs (*Jan* and *Ézè*) appear in the matrix subject position, and importantly, they are linked to a coreferential overt pronoun in the embedded finite clause. I argue that resumption in these so-called *Copy Raising* constructions is the overt counterpart of the same process that licenses long A-movement in examples such as (3-6).

In a nutshell, then, I argue that Hyperraising, Hyper-ECM and Copy Raising constructions are all licensed by the same mechanism, namely resumption. In this respect, my thesis differs crucially from most of the existing analyses of these phenomena, which usually try to explain the unexpected existence of long A-movement in a language in terms of certain language-specific details associated with these constructions. Although I do by no means deny that there are crucial differences between languages regarding the way in which long A-movement constructions are realised, my aim in this thesis has been to rather focus on the similarities and parallels. My goal is to develop a theory of

resumption in A-movement constructions which can be taken to underlie all of the manifold examples of Hyperraising, Hyper-ECM and Copy Raising that I present in the empirical part of this thesis.

I implement the resumptive strategy used in long A-movement constructions by adopting the ‚resumption as stranding‘ and ‚big‘ DP‘ analysis proposed by Boeckx (2003) in his analysis of resumption in A-bar movement constructions. I suggest that languages which allow long A-movement may realise this option by generating a complex DP inside the embedded subject position, which consists of the resumptive pronoun and the overt subject DP. This ‚big‘ DP is theta-marked inside the embedded clause. The head of the ‚big‘ DP (the resumptive pronoun) and its complement-DP show concord-agreement and therefore share all relevant features. However, I argue that the nominative case assigned inside the embedded clause is only available for the resumptive pronoun (the head of ‚big‘ DP), while the specific configuration inside the ‚big‘ DP prevents the complement DP of the resumptive pronoun from getting case (essentially, because the resumptive pronoun is not a case assigner). This, I suggest, is the reason why the overt subject DP must enter an agreement relation with an element in the matrix clause from which it then receives (nominative or accusative) case.

Once the embedded subject DP is case-marked from an element in the matrix clause, it undergoes Hyperraising to either the subject or the object position in the main clause. I also address the question of *how* the embedded subject DP raises from the embedded clause into an A-position in the matrix clause. According to standard assumptions in generative grammar, this type of movement is normally ruled out; A-movement is strictly clause-bound and can only cross the sentence boundary of an embedded clause if this clause is a defective infinitive. In the Minimalist Program, defective infinitives are analysed as bare TPs which lack the C-layer of ordinary clauses. Movement out of a finite CP is therefore ruled out by the Phase Impenetrability Condition (PIC; Chomsky 2001). My analysis, which argues that Hyperraising, Hyper-ECM and Copy Raising constructions all involve A-movement across a CP, must therefore also include a theory about how this type of movement is licensed. I therefore suggest, following Chomsky

(2001), that in languages with long A-movement, the phase head C can be equipped with an *edge-feature*, which attracts the embedded subject-NP/DP to [Spec, C]. I also suggest, contra Chomsky (2005), that movement triggered by an edge-feature of a head H is not necessarily A-bar movement, but can be analysed as A-movement if H bears an uninterpretable feature that acts as a probe in an Agree relation. My analysis therefore leads to the insight that C in languages with long A-movement may bear a formal feature that enters an agreement relation with an embedded NP/DP. When the edge feature of C attracts this DP, the result is A-movement to [Spec, C]. Therefore, the embedded subject NP/DP escapes the effects of the PIC; it remains accessible for further computations outside the phase and can enter further Agree-relations with elements in the matrix clause to value its case feature. Finally, the moved subject can also undergo further movement to another A-position in the matrix clause.

The thesis is organised as follows: Chapter 1 discusses the theoretical background of the research, focusing mainly on Minimalist concepts and operations such as Agree, Move, phase theory, Raising and ECM constructions, and case assignment.

Chapter 2 presents data on languages that manifest long subject-to-subject Raising from finite complements (Hyperraising). Section 2.1, I discuss Raising out of subjunctive finite complements. In section 2.2, data on languages that manifest Raising out of finite indicative complements are presented. In section 2.3, I review Copy Raising out of finite indicative complements, i.e. Hyperraising constructions which leave overt resumptive copies in the embedded clause. I also argue that these constructions differ from comparable “Copy Raising”-constructions in English and Swedish. On the basis of empirical evidence from the occurrence of expletives, interpretation of idioms, long passivisation and scope, I show for each language discussed that the matrix subject is an argument of the embedded finite verb and has moved from the embedded to matrix subject position. The data discussed in this chapter reveal that the phenomenon of Raising out of finite clauses is much more common than standard Minimalist assumptions about Raising would lead one to believe.

In chapter 3, I further discuss existing literature on languages that manifest long subject-to-object Raising out of finite complements (Hyper-ECM). Data from genetically and typologically diverse languages such as Greek, Korean, Turkish, Herero, Quechua, Kipsigis, Chamorro etc show again that this type of long A-movement is widespread. In section 3.1, I provide a detailed discussion of languages that manifest Hyper-ECM, while section 3.2 briefly discusses some data with Copy ECM.

Chapter 4 presents a review of existing approaches to the analysis of Hyperraising, Hyper-ECM and Copy Raising in the Minimalist Program (MP). I begin by discussing the approach that is based on the suggestion that the embedded CP is defective because of lack of tense (Alexiadou & Anagnostopoulou, 1999; Uchibori, 2000, 2001), mood (Aygen, 2004) or the nominal nature of T (Zeller, 2006a). I also review the ‚case assignment’ approach which argues that although case can be assigned in the embedded CP, case assignment could be delayed if there is no expletive in the numeration to satisfy the EPP feature of the matrix T (Rodrigues, 2004). I also present Ura’s (1998) argument that the case feature of the embedded subject DP and the ϕ -features of the embedded T are not checked in the embedded clause because case valuation is only required for convergence. In the small clause approach, Deprez (1992) and Kawai (2006) argue that the embedded DP moves out because the embedded clause is a small clause while the base generation analysis assumes that the copy pronoun originates in the embedded clause, and the matrix subject DP is base generated in the matrix subject position (Harford (Perez), 1997; Potsdam and Runner, 2001; Hoji, 2005). I observe that these theoretical approaches are mostly motivated by idiosyncratic properties of the respective language under investigation. I also point out the various problems with these assumptions.

In chapter 5, I focus on an aspect of grammar that is shared by all languages which permit Hyperraising and Hyper-ECM. I propose that if a language has Hyperraising or Hyper-ECM, it is also a pro-drop language – a correlation which has also been noted by Ura (1994). I present a proposal that explains this generalisation and captures the core properties of Hyperraising and Hyper-ECM. As noted above, in contrast to Ura’s (1994)

approach, and many of the analyses of Hyperraising and Hyper-ECM discussed in chapter 4, my proposal does not imply that the embedded finite clause is defective and that the embedded subject position is a non-case position. Rather, I assume that agreement inside the embedded clause is indicative of the ability of the embedded T-head to license nominative case on the embedded subject. Hence, no deviation from standard Minimalist assumptions is required. Furthermore, I suggest that the role of the resumptive *pro* in Hyperraising and Hyper-ECM is to receive the case assigned by the probing T-head inside the embedded clause. I propose that it is the existence of a resumptive pronoun which causes the coreferential subject DP to be without case, which in turn creates a context in which Hyperraising or Hyper-ECM of this DP becomes possible.

My proposal also provides a link between the languages which allow Hyperraising and Hyper-ECM and those languages with Copy Raising. According to my hypothesis, these constructions are identical in all crucial respects, with the main difference being that the pronominal resumptive copy is a full lexical pronoun in the latter languages, whereas it is a null pronoun in languages with Hyperraising and Hyper-ECM. In 5.1, I present examples showing that all the languages that allow Hyperraising or Hyper-ECM are pro-drop languages. In 5.2, I argue against Ura's (1994) assumption that the embedded subject position of Hyperraising and Hyper-ECM constructions is a non-case position despite the fact that T-head in these constructions exhibits full agreement. In section 5.3, I show that the existence of null resumptive pronouns and of resumptive pronouns in A-movement constructions has been independently motivated in relation to various constructions discussed in the literature. In section 5.4 I provide empirical evidence for the view that the subject gaps in Hyperraising and Hyper-ECM constructions are (resumptive) *pros*. Finally, section 5.5 discusses the technical implementation of the suggested theory of resumption in long A-movement constructions.

In chapter 6, I address the question of how exactly the embedded subject DP undergoes Raising from inside the big DP to the subject or object position in the main clause. This type of long A-movement is not expected to be possible, considering that the embedded CP is a finite or tensed clause. In 6.1, I argue against the assumption that the CP in

Hyperraising and Hyper-ECM is not a phase. In section 6.2, I challenge the assumption that movement to [Spec, C] is always A-bar movement, and I argue that in Hyperraising, Hyper-ECM and Copy Raising constructions, [Spec, C] can become an A-position. In section 6.3, I suggest that the relevant property of the finite C-head that enables the subject of the finite CP to undergo long A-movement is the uninterpretable inflectional feature (uF) which acts as a probe and enters an Agree-relation with the corresponding interpretable feature of the lexical subject DP inside the tensed CP. If the C-head also has an EPP-feature – i.e. the regular edge-feature of C, now attracting the DP which participates in an Agree-relation with the probe of C – then movement to [Spec, C] counts as A-movement. Raising and ECM-verbs therefore ‚enable‘ long A-movement out of their complements by selecting CPs whose heads have uF. I also discuss the nature of the uF of C. In 6.4, I suggest that the properties of the finite clause from which Raising has occurred are basically the same as those of a finite clause with an *in situ* subject, as long as both CPs are selected by a Raising or ECM-verb. Therefore, no distinction between CPs as strong or weak phases is required. The only difference between the non-Raising CP and its Raising counterpart is that in the latter cases, C has an EPP-feature, which attracts the lexical subject to [Spec, C]. I further suggest that since all features originate in the phase heads, it is possible that the features of C are not completely transferred to T. As a result, both T and C can simultaneously enter agreement with one goal but if required, they can also enter separate agreement relations with separate goals which is what obtains when we have the ‚big‘ DP in Hyperraising and Hyper-ECM.

In chapter 7, I summarise the main points of the thesis, comment on its contribution to the understanding of the theory of A-movement and nominative case assignment, and consider the possible implications of the analysis suggested in my thesis. I also account for remaining problematic questions and suggest further areas of research.

CHAPTER 1

Basic assumptions

1.1 Core Ideas of the Minimalist Program

This research is carried out within the framework of the Minimalist Program (MP), the most current version of Generative Grammar and the Principles and Parameters theory. Generative Grammar is a unifying term used for different syntactic theories that have emerged from Chomsky's dominant theory of syntax which he propounded in the mid-1950s and which has been continually reinvigorated by his insight to this date (Chomsky, 1965, 1970, 1977, 1981, 1986a, 1986b, 1995, 2000, 2001, 2004, 2005, 2007, 2008).

The MP builds on the idea that fundamental principles of the knowledge of language are innate and differences between the grammars of languages can be reduced to parameters and language-specific idiosyncrasies. It is assumed that humans are genetically endowed with a mental faculty or device for acquiring language. The in-built set of linguistic principles which underlie the grammars of all natural languages is referred to as Universal Grammar (UG). The innateness of certain aspects of our linguistic competence explains the ease and speed with which a child acquires language and the native speakers' ability to differentiate a well-formed expression from an ill-formed one despite the fact that the input data is restricted. Chomsky (2005:6) suggests that three factors that influence the development of language are: 'genetic endowment', principles which select languages that are attainable so that language acquisition can take place; external data which has to do with experience that aids the selection of one language or the other; and certain principles that are not specific to the faculty of language such as principles of structural architecture and computational efficiency.

Parametric variation can be illustrated by assuming that there is a principle of UG that requires all sentences to have a subject. However, languages may vary with respect to the requirement of an overt subject. This can be explained by postulating a parameter that can be set differently in different languages; this parameter would then capture the variation.

Consider the contrast between the Italian examples in (1a) and (1c) below and their English equivalents in (1b) and (1d):

- (1) a. Maria parla francese.
- b. Maria speaks French.
- c. Parla francese.
- d. *Speaks French.

(Radford, 2004: 17)

The verb *parla* ‚speaks’ as used in (1) is a two-place predicate that requires a subject that is human as well as an object. Moreover, *speaks* is a finite verb that requires agreement with its subject. In the Italian and English examples in (1a) and (1b), both requirements are met and both sentences are grammatical. In the Italian example in (1c), *parla* is overtly marked for agreement without a visible subject. In contrast, its English equivalent in (1d) is ungrammatical due to the absence of an overt subject. The contrast between the Italian and the English examples in (1) therefore suggests that in Italian, finite verbs can have null subjects (*pro*) whereas finite verbs in English obligatorily require an overt subject. The child learning Italian will have to select the null-subject option of the parameter while the child learning English selects the non-null-subject option.

A language consists of a computational system (a grammar) and a mental lexicon which includes the lexical items of the language⁴. Each lexical entry in the lexicon contains information about the meaning, pronunciation, syntactic category, argument structure, etc of the lexical item. Lexical items are split into two categories – content words and function words. Content words are words that have descriptive content such as Noun (N), Verb (V), Preposition (P), Adjective (A) and Adverb (Adv). Function words, on the other hand, are words that carry grammatical information (person, number, case, sentence type etc). The core functional categories that play an important role in the MP are the

⁴ In contemporary linguistic theories (including the MP), the mental lexicon is also conceptualised as a computational system.

categories of light verb (v^5), Tense (T) (which hosts tense and agreement features and is responsible for nominative case assignment) and Complementiser (C) (for sentence type). There may be additional functional categories in each of these three domains of the clause. For instance, C may be a cover term for a set of functional categories such as Top(ic), Foc(us), Fin(iteness), etc, and the category T may split into Asp(ect), Mood, etc. Lexical items that represent the category T are certain auxiliaries and modal verbs; examples of the C-category are conjunctions like *that*, *if* and *for*.

An important assumption in the MP is that all syntactic parameters are associated with grammatical features of functional categories. For example, the pro-drop parameter is associated with the morphological richness of T (cf. Rizzi 1982, 1986; Alexiadou and Anagnostopoulou 1998). Minimalist theories of linguistic variation try to identify which features of which category are responsible for grammatical differences between languages.

The computational system of syntax builds structures from lexical items by using two fundamental operations: Merge and Move. When two lexical items are merged or combined (external Merge), one of them projects a phrase of the same type. Phrases are further combined with other words or phrases in order to form sentences. Both content and function words can project a phrase. For example, if a noun like *book* combines with the determiner *the*, a Determiner Phrase (DP)⁶ *the book* is derived. The determiner is referred to as the *head* of the DP. The upside-down tree diagram in (2) shows the relations between the lexical items that make up this DP.

(2)

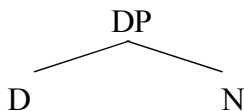

⁵ The nature of the light verb v is discussed below.

⁶ In the earlier version of Generative Grammar, expressions like ‚the book’ were taken to have the categorial status of Noun Phrase (NP). In my thesis, I follow the standard Minimalist practice and, based on work by Abney (1987), analyse noun phrases such as *the book* in (2) as DPs.

The operation Move involves copying an item already existing in the structure and remerging it elsewhere in the structure (internal merge). This operation can be best illustrated when the syntactic representation of the bracketed embedded clause in (3a) is considered:

(3a) It seems [that he will read this book]

(3b)

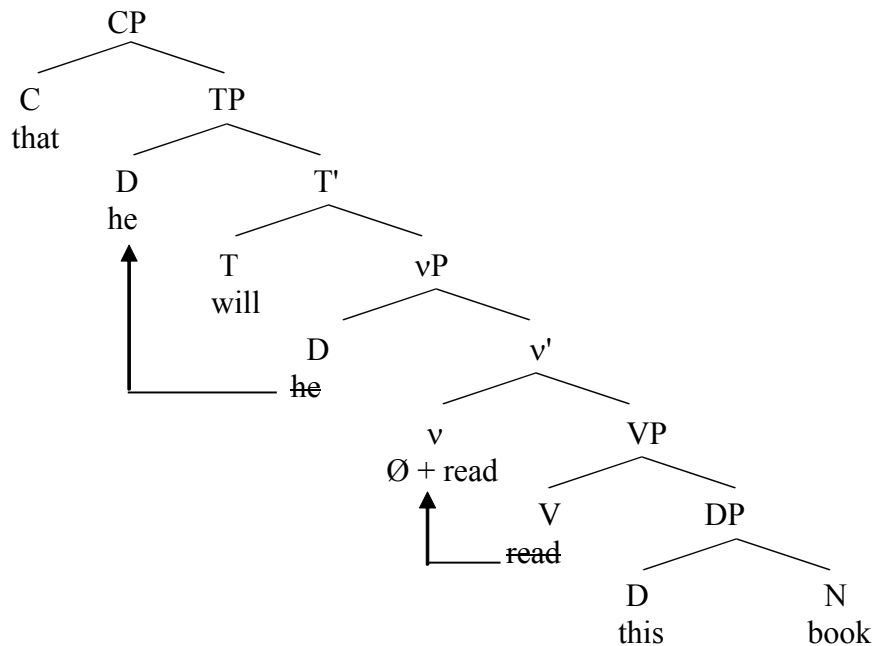

In (3b) *this* (D) merges with *book* (N) to form the DP *this book*. The derived DP merges with *read* (V) to form the VP *read this book*. The so-derived VP merges with the light verb *v* in order to derive the *v'*. As I illustrate in (3b), the function of the light verb is to introduce the subject argument and to link the subject to the (VP-) predicate. In languages such as English or Zulu, the light verb is a “null element” – (it lacks phonological features but still has semantic and syntactic significance in the structure). The light verb *v* is affixal in nature, it therefore triggers *read* (V) to adjoin it (an operation known as head movement). The syntactic position of the light verb and the movement of V to *v* are illustrated in the representation (3b) above. The *v'* further merges with its so-called

specifier, the subject DP *he*, to derive the *vP*. The propositional content of a sentence is syntactically represented within the *vP* through the verb (plus light verb) and their arguments (subject, object) (cf. Larson 1988, 1990; Hale and Keyser, 1993).

In order to be specified for tense, *vP* merges with the tense-head T (the modal *will* in (3)) to derive the T' – *will he read this book*. As noted above, functional categories like T have grammatical features and these features are highly significant when syntactic relations between elements in the syntactic representation are considered. In the following paragraphs, I provide a short illustration of the mechanisms induced by grammatical features that play an important role in the derivation of a sentence.

Grammatical features can be interpretable or uninterpretable. The tense feature of T, for example, is interpretable, since it contributes to the temporal interpretation of the sentence. In contrast, the agreement features of the T-head are uninterpretable. Importantly, Chomsky (1995) argues that uninterpretable features must be deleted from the syntax before a sentence is transferred to the semantic component of the language faculty for interpretation. In order to become deletable, however, uninterpretable features must enter an *Agree*-relation with corresponding interpretable features of the same type. This means that at the point where the T-head is introduced in the derivation, it will start looking for a matching constituent with interpretable agreement features. In the terminology of Chomsky (2000), the uninterpretable features of the T-head serve as a *Probe* that seeks a *Goal* with matching features to agree with. The search domain of the Probe is everything that is C-commanded by the functional head which hosts the Probe, with C-command defined as in (4):

(4) *C-command* (Haegeman 1994:134)

α C-commands β if and only if

- (i) α does not dominate β and β does not dominate α
- (ii) the first (= lowest) branching node that dominates α also dominates β

In (3b), the next matching Goal located within the C-command domain of T's agreement features is the subject DP *he* in [Spec, *v*]. These agreement features – person, number, gender – are also known as phi- (ϕ -)features. Note that the agreement features of a DP are interpretable (it makes a semantic difference if a noun phrase is 2nd person or 3rd person, or singular or plural), so the T-head with uninterpretable agreement features agrees with the interpretable agreement features of the DP *he*. In this process, T's agreement features are valued as 3rd person singular.

Another important mechanism in the MP concerns case assignment. In Chomsky (2000, 2001), it is assumed that features of, say, a DP or T can enter into the derivation as either interpretable or uninterpretable. Interpretable features are assumed to be inherently valued, while uninterpretable features are unvalued. For instance, the ϕ -features of a DP enter into the derivation as already valued, but the case feature of a DP enters the derivation unvalued. Since the ϕ -features of T are uninterpretable, they are also unvalued when T enters the derivation. In order for the uninterpretable ϕ -features of T to be given a specific value, the uninterpretable features of T must enter an Agree relation with a DP – an element with matching interpretable features. Agree then establishes that the feature values of the DP's ϕ -features also become the values of T. As a result of the Agree-relation between a finite T-head and the subject DP, finite T values the case feature of a DP (another uninterpretable feature) as nominative. Informally, T has “assigned” nominative case to the subject DP under agreement. Once the uninterpretable ϕ -features of T and the uninterpretable case feature of the DP have received specific values, they are deleted and are no longer visible in the syntactic or semantic component (they obviously remain visible to the phonological component which determines that T in (3b) is pronounced as *will* and the subject as *he*).

In languages like English, the T-head is assumed to have another uninterpretable feature, called an EPP-feature. This feature is an implementation of what used to be the Extended Projection Principle in Government and Binding Theory, a principle which required that the subject position of a sentence be filled. Importantly, the EPP-feature can only be deleted if a suitable phrase is merged with the projection of T (i.e. T'). In languages like

English, the subject DP marked for nominative is a suitable phrase.⁷ Therefore, agreement between T and the subject is followed by an application of the operation Move (also known as internal Merge):⁸ the subject DP in [Spec, ν] is copied and remerged with T'. Since the copy of the subject DP in [Spec, ν] is not pronounced, it looks as if the subject DP has moved from [Spec, ν] to [Spec, T], but “movement” is actually no more than a metaphor for the process of copying an element already part of the structure and merging it with the root of the derivation at this point. The subject DP therefore merges with the T' *will read this book* to derive the TP *he will read this book*. Finally, in order for the sentence to be specified for sentence type, the TP combines with the complementiser *that* to form the embedded declarative CP *that he will read this book*.

Recall that certain function words can lack phonological features (they are not pronounced) but are still present in the syntax, due to their grammatical (and possibly semantic) features. For example, the complementisers which introduce declarative main clauses in English are phonologically null, and the T-head of the feature [+past] does not have a phonological realisation either (instead, this feature is realised by inflectional morphology on the verb):

(5a) He recommended this book.

⁷ In some Bantu languages (Perez, 1985; Baker, 2003) and Scandinavian (Holmberg, 2000) languages, and perhaps even in English locative inversions, non-nominative elements can also satisfy the EPP feature of T.

⁸As noted in the text, there is also head movement from V to ν in (3b). Since the nature of and the trigger for head movement are of no particular relevance to the discussion and analysis of this thesis, I do not discuss them in much detail here.

(5b)

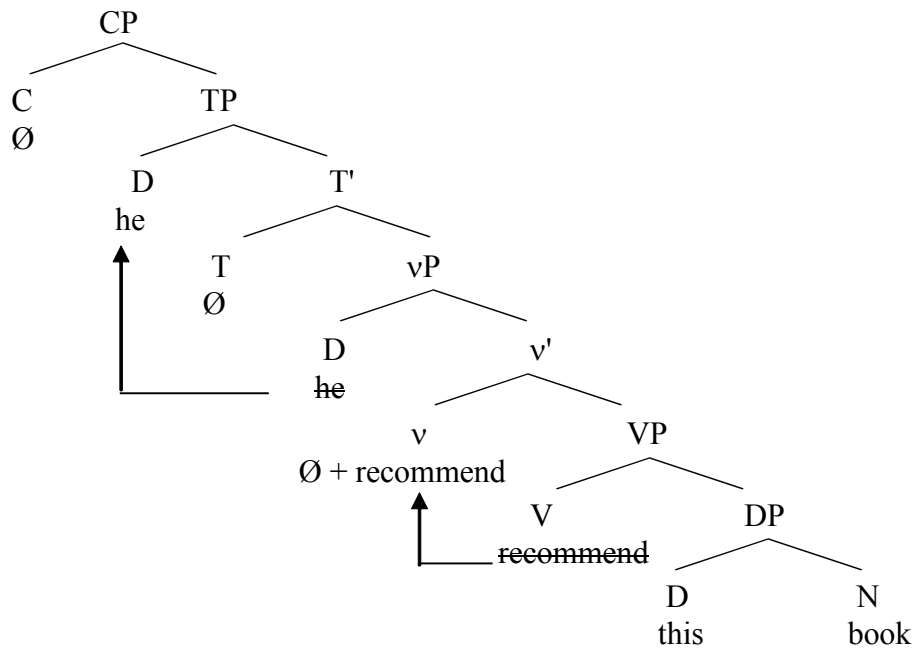

In (5b), C, T and v are null constituents, but they still have grammatical and semantic features that contribute to the meaning of the sentence and drive the syntactic derivation.

1.2 Phases

In order to derive a given expression, a set of lexical items (words, functional heads) known as the *Lexical array* is selected from the lexicon. In the MP it is assumed that syntactic derivations proceed in incremental pieces called *phases*. Each phase is built from a specific and separate lexical *Subarray* chosen from the lexicon. Once a given set of lexical items has been used to derive a phase, the computation selects another subarray of items to build the next phase. The process is repeated until the desired expression is derived. According to Chomsky (2000:108), CP and vP are phases. With respect to vP, Chomsky draws a further distinction between *strong* and *weak* phases. A transitive light verb phrase with full argument structure (an internal and an external argument) is a strong phase (labelled v^*P^9); a vP built from unaccusative verbs, including passives, counts as a

⁹ In the remainder of the thesis, I do not distinguish between vP and v^*P , and use vP also when referring to a strong light verb phase.

weak phase¹⁰. This means that, depending on its feature specification and argument structure, the light verb head *v* can project either a weak or a strong phase.

Chomsky's (2000) rationale for regarding CP and vP as phases is that a CP represents a complete clausal complex with a specification of sentence type while a vP represents a complete argument structure (external and internal arguments). Importantly, Chomsky (2005) suggests that a non-phase head like T does not have inherent grammatical features. Rather, T inherits its ϕ - and tense features from the C-phase-head. Without C, T has no agreement or tense features. It counts as defective, and crucially, cannot assign nominative case.

The general idea about phases is that once a complete phase has been derived, the complement of the phase-head (such as the TP complement of a C-head and the VP complement of a *v*-head) will undergo transfer to the phonological and semantic components for appropriate phonetic and semantic interpretation. Consequently, the transferred structure will then be unavailable for further syntactic operations. However, *the edge* of the phase (that is its specifier and its head) remains accessible to grammatical operations outside the phase. This idea suggested by Chomsky (2000: 108), is known as the *Phase Impenetrability Condition* (PIC), which is given in (6):

(6) *Phase Impenetrability Condition* (Chomsky, 2000: 108)

In phase α with head H, the domain of H [= complement of H] is not accessible to operations outside α , but only H and its edge [H plus any/all its specifiers].

The domain of H is every constituent C-commanded by H; H and [Spec, H] constitute the edge of H. For example, the PIC implies that a subject in [Spec, T] is not available for any operation outside the CP: Given that CP is a phase, [Spec, T] is in the domain of the

¹⁰ Legate (2003) shows that passives and unaccusatives are also strong phases.

phase head C. This explains, for example, why one would not expect the subject of an embedded clause to receive case from an element in the matrix clause.

As an illustration of how the PIC works, consider (3a). Within the embedded clause, the vP is a phase. When the T-head-Probe searches for a goal, it can only locate the subject in [Spec, v], but not the DP-complement of the verb, since this object is C-commanded by the phase-head v. However, the PIC does not prevent T and the subject to enter an Agree-relation. Once the embedded CP is completed, it merges with the matrix verb *seems*, and the matrix clause is derived along similar lines. However, the subject DP *he* within the embedded CP cannot enter any grammatical relation with any functional head outside the CP. This is because the embedded CP is a phase; by the time the matrix verb, the matrix v- or matrix T-head enter the derivation, the embedded subject DP has already been transferred to the phonological and semantic interfaces. The embedded subject, whose case feature has been valued by the finite T in the embedded clause, is no longer available for further syntactic operations, and no grammatical operations like movement can take place across a phase boundary.

1.3 The Standard Analysis of Raising in the MP

It is generally assumed that all “regular” clauses are CPs which have T-heads with complete agreement and tense features (inherited from C) that are required for nominative case valuation of the subjects. However, some infinitives are bare TPs which lack a C-phase layer. Since T’s features are inherited from C, the T-heads of these clauses lack complete agreement and tense features, and the clauses are deemed defective (Chomsky, 2001: 6).

Raising constructions are examples of constructions whose complements are considered defective. Consider the English example in (1) from the introduction, repeated here as (7):

- (7) a. It seems that he loves mashed potatoes.

b. He seems to love mashed potatoes.

(8)

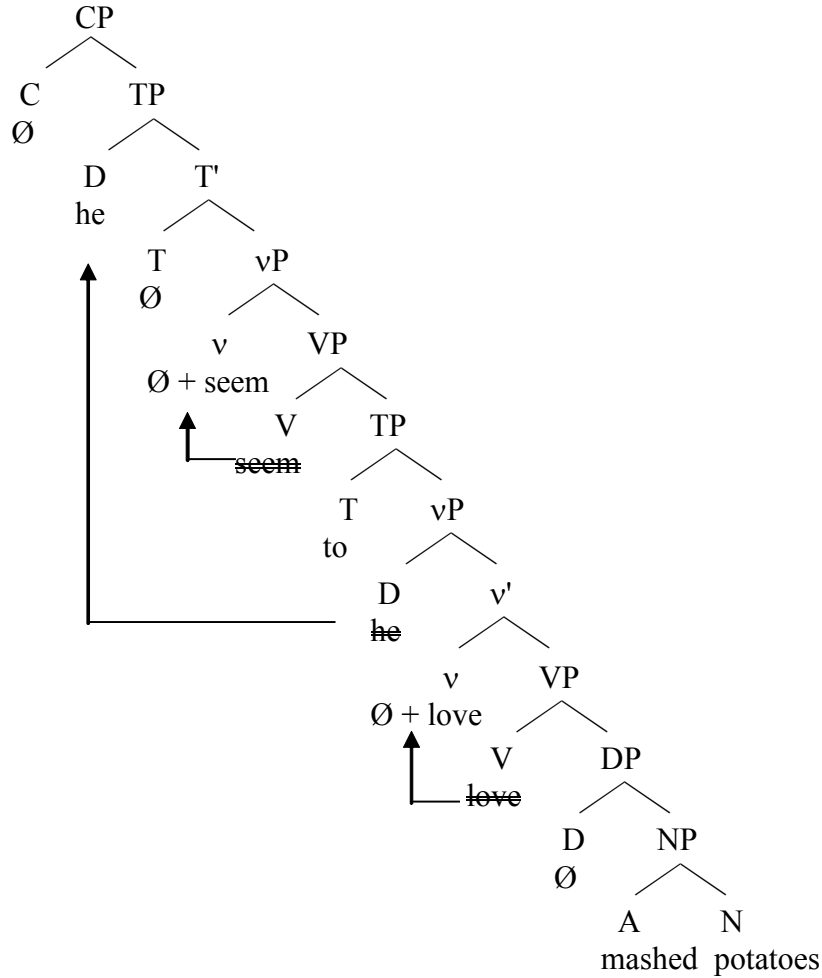

The embedded clause in (7a) is a CP. This implies that T has a complete set of grammatical features (ϕ -features and tense); therefore, the embedded subject *he* gets nominative case. Once the case feature of *he* has been valued, *he* becomes „frozen in place’ (i.e. it becomes inactive) and can no longer be involved in any syntactic operation (Chomsky 2001: 80). One distinctive feature of Raising predicates such as *seem* is that they are unaccusative and do not assign an external thematic role. For this reason, it is possible for an expletive – a semantically null element like *it* – to be inserted as the subject of a Raising predicate (as in 7a).

However, when the verb *seems* selects an infinitival complement clause in (7b), the picture changes. The thematic subject of the embedded infinitive *he* is now in the matrix subject position, which suggests that it has undergone Raising in (7b), i.e. movement to [Spec, T] of the matrix clause. However, this sort of movement, and the long-distance Agree-relation between matrix T and the embedded subject that licenses this movement, is only compatible with the PIC if it is assumed that no phase boundary intervenes between the two. This conclusion has led to the assumption in the MP that the embedded clause in (7b) is not a full CP. Rather, (8) shows that the complement of *seem* is a bare TP. In order to make concrete the exposition on Raising, I discuss the consequence of this assumption and the derivation of the sentence in (7b) shown in (8) in some detail.

The derivation of the sentence in (7b) proceeds like that in (5a) until we have reached the stage of the derivation where the embedded T has been merged with the vP to create the TP *to he love mashed potatoes*. In accordance with the assumption that vP is a phase, the embedded VP will undergo transfer at the end of the vP cycle, and only the subject DP *he* and the verb on the edge of the vP (in [Spec, v] and v respectively) remain visible and accessible in the syntax. Since by assumption, Raising infinitival complements are TPs (not CPs), there is no phase head C, which means that the infinitival TP is now directly merged with the matrix verb V. This has a first important consequence. Without a C-head from which T can inherit its features, the embedded T lacks tense and agreement features (T is defective). However, as noted above, a defective T cannot value the case feature of a DP; the infinitival T-head *to* in (7b) and (8) is unable to assign nominative case to the embedded subject-DP *he* in [Spec, v]. Without its case feature valued by the embedded defective T, the embedded thematic subject remains active.

The derivation now proceeds with TP combining directly with the Raising verb *seems* in order to derive the VP, which in turn merges with the affixal null light verb in order to derive the matrix vP. Since *seems* is unaccusative and does not have a full argument structure (there is no external argument in the matrix [Spec, v]), the matrix vP is not a phase. The vP now combines with matrix T to form the T'. Since matrix T is finite and has uninterpretable ϕ -features, it acts as a Probe and searches a Goal in its C-command

domain. Now, there is a second important consequence of the fact that embedded Raising infinitives are not CPs: there is no phase boundary intervening between the non-defective matrix T and the embedded subject DP. Therefore, matrix T can enter an agreement relation with the embedded subject and assign case to it.¹¹ The EPP feature of T subsequently causes the embedded subject to raise to the matrix subject position; the subject DP *he* then merges with the T' to derive the TP. The derived TP finally merges with a null declarative complementiser to form the CP.

From this discussion, it is apparent that Raising is only possible from bare infinitival TPs like the one in (7b). The mechanisms of agreement and case assignment postulated by the MP and the theory of phases imply that Raising should be neither necessary nor possible from embedded CPs.

Some Raising constructions in which the case of the embedded subject DP has been valued by matrix T allow for an alternative way for a matrix T to satisfy the EPP requirement to have a DP specifier. With certain types of embedded infinitives and an indefinite subject, it is possible for this embedded subject to remain in [Spec, v] of the embedded infinitive, in which case an expletive – a dummy, semantically empty element – is merged into [Spec, T] of the matrix clause. English has two expletive pronouns *it* and *there*. Because they are not referential, they do not carry any interpretable ϕ -features. Expletives are grammatical elements without semantic features. They are used in order to fulfil the EPP condition that stipulates that the subject position must be filled. In languages like English where the subject is sometimes allowed to remain in [Spec, v], the expletive *there* is required in [Spec, T] to satisfy the EPP requirement of T, see (10):

- (9) a. Someone is playing in the garden.
b. There is someone playing in the garden.
- (10) a. People seem to be playing in the garden.

¹¹ T's features are valued as 3rd person by the subject DP *he*; this is morphologically reflected by the agreement morphology on the verb (*seem-s*).

- b. There seem to be people playing in the garden.

It has been proposed that the ϕ -features of *there* are defective because the only feature carried by expletive *there* is an uninterpretable person feature (Chomsky 2001). In (9b) and (10b), T C-commands and agrees with the subject in [Spec, v]. Therefore, the expletive *there* in (9b) and (10b) is required in [Spec, T] only to value the EPP feature of T. However, in constructions with verbs which do not select an external argument, a DP cannot occupy the subject position. In such constructions, the second type of expletive *it* must be merged in [Spec, T] as in (11) below:

- (11) It is snowing.

In contrast to *there*, *it* has a complete set of ϕ -features. Since both *it* and BE^{12} are ϕ -feature complete, each can value and delete the uninterpretable feature of the other. Subsequently, BE will be spelled out as *is*.

1.4 The Standard Analysis of ECM Constructions in the MP

ECM constructions are very similar to Raising constructions, with the difference being that the matrix predicate in ECM constructions is not unaccusative, but transitive. Both ECM and Raising constructions select defective infinitival complements. Consider the ECM constructions in (12):

- (12) a. I believe her to be smart.
b. I believe that she is smart.
c. *I believe she to be smart.

In contrast to Raising constructions, where the embedded subject of a non-finite clause is assumed to be assigned nominative case by the matrix finite T-head, in the ECM

¹² I use SMALL CAPS to refer to the uninflected form of the copular verb whose agreement features still have to be valued

construction in (12a), the embedded subject *her* is assumed to have been assigned accusative case by the matrix light verb *v* because *her* is unable to get nominative case in the defective embedded non finite clause. As in the case of the Raising construction discussed above, the embedded subject in (12a) is able to have access to accusative case from the matrix light verb because the embedded complement in (12a) is assumed to be a bare TP, and not a full CP. In (12b), the embedded subject DP is assigned nominative case by the embedded finite T-head. Therefore, the embedded DP remains in the complement clause as expected, and the sentence is grammatical. In contrast, in (12c), the embedded subject of the non-finite defective complement is realised as nominative *she*. Because a defective non-finite clause lacks the features required for valuing the case feature of its subject as nominative, the sentence in (12c) is ungrammatical. The fact that the embedded subject DP in (12a) is realized as *her* instead of *she* is an indication that the embedded subject DP has been assigned accusative case by the matrix light verb. Since it is the exception rather than the rule for a matrix light verb to assign accusative case to the subject of a complement clause, the type of case assignment manifested in (12a) is referred to as Exceptional Case Marking (ECM).

ECM predicates are transitive. Therefore, while Raising predicates like *seem* do not assign case to an object DP (Raising predicates only take sentential complements) hence, the ungrammaticality of (13b), an ECM verb like *believe* can assign case to an object DP. This is evident from its ability to occur in simple transitive structures like (13a) where *believe* assigns accusative case to its object *them*:

- (13) a. I believe them.
b. *I seem them.

Furthermore, ECM predicates also select external arguments and, in contrast to Raising predicates, therefore do not take expletives as their subjects (Epstein and Seely, 2006). They do, however, allow for expletives to appear in their object position. Examples of this sort are discussed in section 1.6 below.

Notice, however, that when an ECM construction is passivised, it yields a Raising structure, because the passivised ECM-verb with its defective TP complement is now unaccusative and therefore behaves exactly like a Raising verb. Consequently, the subject of the complement of a passivised ECM predicate like *believe* becomes the subject of the matrix clause:

(14) She is believed to be smart

Generative analyses differ with respect to the question of whether the embedded subject in an ECM construction which receives accusative case from the matrix clause actually also raises to the matrix object position. In the ECM account of an earlier version of the Principles-and-Parameters-approach that underlies the MP known as Government and Binding theory (Chomsky, 1981), it was assumed that languages like English have a rule of S'-deletion (COMP deletion) peculiar to certain types of matrix verb, which allows this matrix verb to govern and assign case to the DP in the embedded subject position without the embedded DP moving out of the embedded clause.

(15) a. *I believe [_{COMP} [_S her to be smart]]
b. I believe [_S her to be smart]

It was assumed in this ECM account that a rule of COMP-deletion is applied to (15a) which then derives (15b). The COMP in (15a) is deleted so that the embedded subject can be assigned case by the matrix verb since a non-finite embedded T cannot assign nominative case. The structure in (15a) is ungrammatical because the embedded subject cannot be assigned nominative case in the non-finite embedded clause, and S' was taken to be a barrier that blocks access to accusative case from the matrix light verb. In contrast, (15b) is grammatical because it was assumed that the COMP-deletion rule had been applied. Therefore, the embedded subject DP has access to accusative case from the matrix verb without having to move out of the embedded complement.

The Raising account, first introduced by Rosenbaum (1967) and more recently re-introduced by Johnson (1991), Koizumi (1993, 1995), Radford (2004) and Hong (2005), assumes that the embedded subject DP overtly moves in the syntax and ends up in the matrix object position. Like the non-Raising account, the Raising account also assumes that in languages like English, the embedded clause is defective and is therefore a TP. The defective embedded T in (16) cannot assign nominative case to its subject, however, because the embedded complement is a TP and not a phase like CP, the embedded subject DP can get accusative case from the matrix light verb. Subsequently, it has been suggested that the EPP features of the matrix light verb trigger the movement of the embedded subject DP into the matrix [Spec, v] position (see e.g. Radford, 2004).¹³ In order to derive the correct word order then, it also needs to be assumed that the matrix ECM-verb (*believe* in (16)) moves to a location that is higher than the landing site of the embedded subject DP:

(16) [I believe her [_{VP} ~~believe~~ [_{TP} ~~her~~ to be smart]]]

Because the surface order does not show the position of the embedded subject in (15b) and (16), it is not really clear whether the embedded subject in ECM constructions remains *in situ* in the embedded clause or moves into the matrix clause. Although the theory of Agree allows for both options, there are reasons to believe that the embedded subject in ECM constructions moves to the matrix object position. Runner (2006) observes that the position of the adverb and certain particles in ECM structures such as (17a) and (17b) is one piece of evidence for the idea that ECM constructions involve Raising-to-object:

- (17) a. Mary expected him mistakenly to look out for the kids.
 b. Mary made him out to be notorious.

¹³ However, note that there is no consensus among researchers on the matter of the exact landing site of the raised DP in the matrix clause.

In (17) the adverb *mistakenly* (17a) and the particle *out* (17b), which are understood as modifying the matrix verb, are positioned after the DP *him*, which is the thematic subject of the embedded clause. For the adverb *mistakenly* and the particle *out* to have a matrix interpretation, the standard assumption is that they must be in the matrix clause in (17a) and (17b). This implies that the DPs immediately preceding the adverb and the particle must be in the matrix clause. In contrast, the word order in (16) is incompatible with the idea that the embedded subject of an ECM-construction remains *in situ* inside the embedded clause. In the light of the argument in (17), I adopt the assumption that ECM-constructions also involve Raising-to-object.

To conclude, I again discuss the derivation of an ECM construction such as (18) *I believe her to love mashed potatoes* in a step-by-step fashion below.

(18)

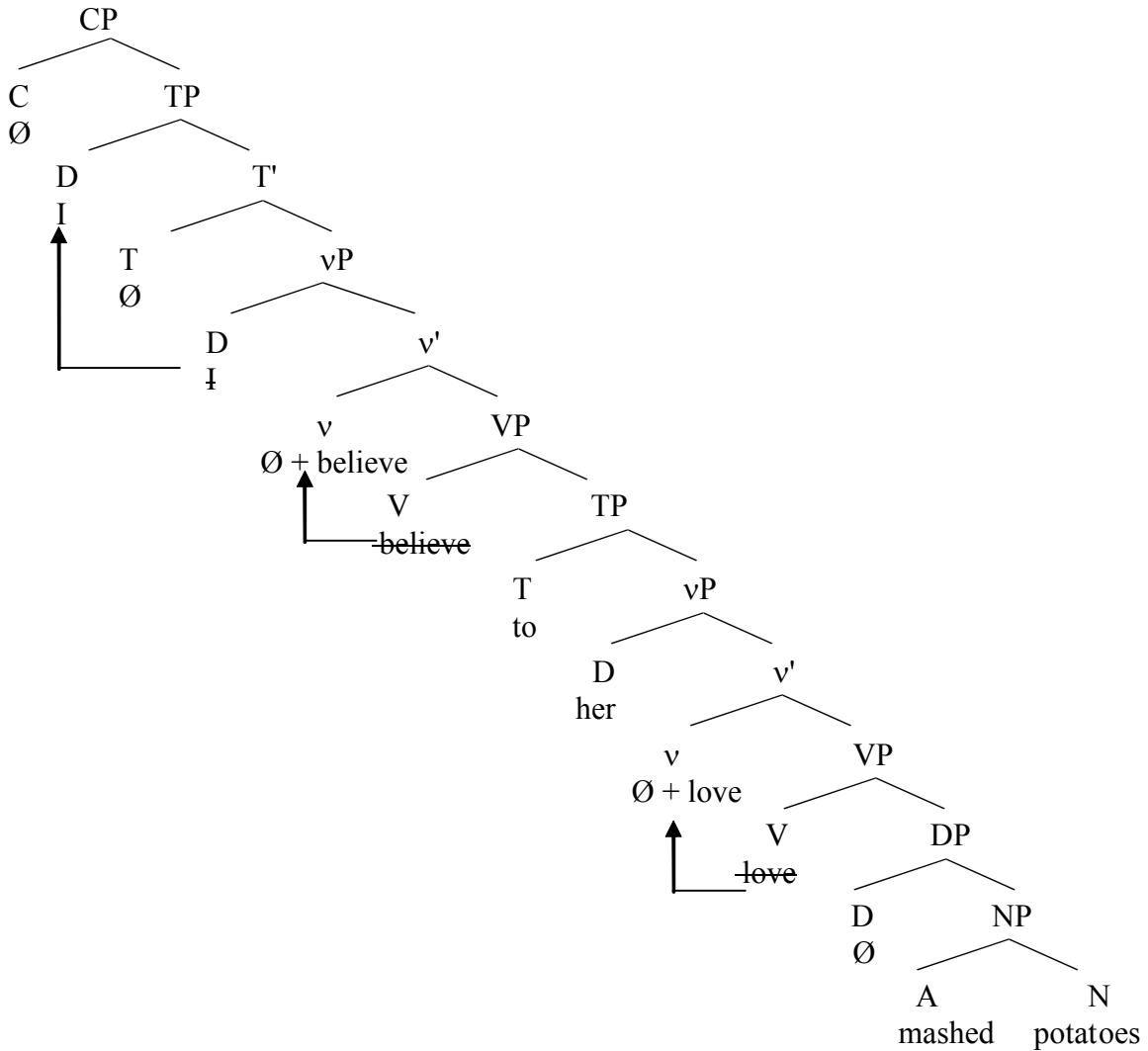

The derivation of (18) proceeds as before (see (8)) until it reaches the stage when the embedded TP is merged with the matrix V which originates as the head of the matrix VP, the complement of the matrix light verb. Since the light verb is transitive and C-commands the infinitive subject with matching person and number features, each can value and delete the uninterpretable feature of the other. As a result, the embedded subject is assigned accusative case by the matrix light verb and spelled out as *her*. The matrix light verb, being transitive, also projects an external argument *I* with interpretable first-person singular features, but an unvalued case feature. The external argument *I* merges with v' to derive the vP, which in turn merges with a null finite T which has an

interpretable present-tense feature, uninterpretable and unvalued ϕ -features, and uninterpretable EPP features. Merging T with its vP complement derives the T'. Since matrix T is finite and has uninterpretable agreement features, it can act as a Probe and agree with the Goal *I* with matching agreement features in its C-command domain. This results in the pronoun *I* valuing and deleting the person and number features of the matrix T, and conversely in the T valuing the case feature of *I* as nominative and deleting it. The EPP feature of T subsequently triggers Raising of the pronoun *I* from [Spec, v] to [Spec, T], thereby deleting the EPP feature on T. Merging of the subject DP *I* to the T' derives the TP. The derived TP finally merges with a null declarative complementiser to form the CP: *I believe her to love mashed potatoes*.

1.5 Raising versus Control

As far back as Rosenbaum (1967), it has been acknowledged that Control infinitives are different from Raising infinitives. Compare (19a) and (19b):

- (19) a. He tries to eat mashed potatoes.
b. He seems to love mashed potatoes.

(19a) is a so-called Control infinitive while (19b) is a Raising infinitive. Control and Raising constructions differ in a number of ways. First, they differ with regards to the thematic properties of their matrix verbs. While Control verbs like *try* in (19a) usually select external arguments, Raising verbs like *seem* in (19b) are unaccusative and do not select their subjects. Rather, the subject of a Raising verb originates inside the infinitive and moves to the matrix subject position.

Secondly, the embedded subject position of a Raising infinitive construction is occupied by the unpronounced copy of the moved subject. In contrast, the embedded subject position of a Control construction is filled by a *PRO*, a null subject ‚controlled’ by an obligatorily coreferential antecedent DP in the matrix subject position. Therefore in (19a), the matrix subject DP *he* is base-generated in the matrix clause as the argument of *try* and

controls *PRO* in the embedded subject position. In contrast, in (19b), *he* is base generated in the embedded clause as the argument of *love* but moves from the infinitival clause to the matrix clause. (20) and (21) below are schematic representations of the differences between Raising and Control constructions, adapted from Zeller (2006a). The *t* in the subject position of the infinitive in (21) represents the null trace/copy of the raised DP that has been given a null spell out:

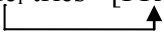
(20) He_i tries [PRO_i to eat mashed potatoes]

(21) He_i seems [*t*_i to eat mashed potatoes]

The standard assumption is that Raising and Control constructions are only possible with infinitival complements (cf. Stowell, 1982; Watanabe, 1993, Martin, 2001; Cowper, 2002). Since the T-head of infinitives lacks tense and agreement features required for nominative case assignment, no overt DP can occupy the subject position of an infinitive. Conversely, the subject position of finite clauses cannot be occupied by *PRO* or DP-trace. If a finite clause does not have an overt subject, it is generally assumed that the subject position is occupied by another type of null subject called small *pro*: the null pronominal found in the subject positions of null subject languages like Italian. The Italian example in (22) is from Zeller (2006a: 7):

(22) Maria_i dic-e [che (pro_{i/j}) abit-a in riva al mare]
 Maria say-3SG that live-3 SG on edge of sea
 ‚Maria says that s(he) lives by the sea.‘

However, Raising and Control structures do not only exist in infinitives, they are also found in subjunctive clauses. For instance in Balkan languages like Greek, Bulgarian, Romanian, Albanian, etc, which lack infinitives, subjunctive complements allow *PRO*

analysed in terms of control in their subject positions (cf. Iatridou, 1993; Watanabe, 1993; Terzi, 1997; Krapova, 1998; Landau, 2004 and references cited therein):

- (23) o Janis_i prospaθise [(PRO_{i/*j}) na figi]
the John tried-3SG SUBJ leave
'John tried to leave.'

(Greek; Roussou, 2001: 77)

- (24) Ivan uspjaja [(PRO_{i/*j}) da ostane pri nego]
Ivan managed-3SG SUBJ stay-3SG with him
'Ivan managed to stay with him.'

(Bulgarian; Krapova, 1998: 76)

In (23) and (24), the embedded null subject cannot be replaced by an overt subject and is always understood as being coreferential with the matrix subject. These attributes therefore indicate that the null subject of the subjunctive complements in (23) and (24) must be *PRO* and cannot be analysed as a *pro*. The embedded pro-subject in the Italian example (22) may refer to the matrix subject *Maria* (hence, both *Maria* and the *pro* are given the same indices). *pro* may also have another referent besides *Maria*, in which case, *pro* is given another index. In addition, the null subject may alternate freely with a lexical DP and an overt pronoun, as shown in (25) below:

- (25) Maria_i dic-e [che Francesco abit-a in riva al mare]
Maria say-3SG that Francesco live-3SG on edge of sea
'Maria says that Francesco lives by the sea.'

(Italian; Zeller, 2006a: 8)

It is important to be aware of these differences between Raising and Control constructions, because they play a crucial role in determining whether a particular construction involves Raising or Control.

1.6 Tests for Raising

Specific diagnostic tests for Raising which have been established for unquestionable cases of Raising are used as test criteria for controversial cases of Raising. These diagnostic tests are an important syntactic method because they help differentiate between Raising and Control constructions. Some of these traditional arguments for distinguishing between Raising and Control constructions, such as the possibility of an expletive subject, preservation of idiomatic meaning, preservation of truth equivalence under passivisation, scope ambiguity, etc, are discussed in this section.

An indication that Raising has occurred is that an idiomatic expression retains its idiomatic meaning under Raising, but in a Control construction, the same expression can only be given a literal interpretation (Postal, 1974; Davies and Dubinsky, 2004).

- (26) a. The cat seems to be out of the bag.
b. The cat wants to be out of the bag.

As (26a) shows, the idiomatic meaning of the expression *the cat is out of the bag* is intact because the raised DP *the cat* can be semantically linked to the embedded predicate. In contrast, the Control construction in (26b) can only be given a literal interpretation because the DP *the cat* is base-generated in the matrix clause and receives its theta role from the matrix predicate *wants*.

Another means of distinguishing Raising from Control constructions is comparing the behaviour of Raising and Control structures when the complement clause is passivised. When the embedded verb of a Raising predicate is passivised with its arguments switched, such that the embedded object becomes the matrix subject, the meaning of the passive sentence is similar to that of the active sentence. (27a) below is synonymous with (27b):

- (27) a. John seems to have loved Mary.
b. Mary seems to have been loved by John.

In contrast, the Control sentences in (28) are not synonymous:

- (28) a. John wants to kiss the girl.
b. The girl wants to be kissed by John.

Interchanging the arguments in the Control construction in (28) alters the meaning of the sentences. The reason for the similarity in meaning of the passive and active Raising constructions in (27) is that the DP *Mary* is the internal argument of the verb *love* in both examples, even though it is syntactically realised as the subject of the main clause in (27b). In contrast, the subject of a Control verb like *want* receives a theta role from the main verb in (28b) and can therefore not be interpreted as the internal argument of the embedded predicate.

Another diagnostic distinguishing Raising from Control constructions is that Raising constructions are capable of both narrow and wide scope interpretations while Control constructions can only have the wide scope reading (Williams, 1994):

- (29) a. No one_i tends [t_i to be there].
i. „It tends to be the case that no one is there.’ (Narrow scope: *tend* has scope over *no one*)
ii. „There is no one such that he/she tends to be there.’ (Wide scope: *no one* has scope over *tend*).
- b. No one_i wants [PRO_i to be there].
i. *„It is wanted that no one should be there.’ (*Narrow scope).
ii. „There is no one such that he/she wants to be there.’ (Wide scope).

(Williams, 1994: 126-127)

It is possible for the quantified subject in the Raising Construction in (29a) to have both the wide scope reading and the narrow scope reading (the natural interpretation) with

respect to the matrix verb, because the raised DP leaves a copy in its base position in the embedded clause. In contrast, the subjects of Control predicates like the one in (29b) are base generated in the matrix clause and do not have copies in the embedded clause. As a result, only the interpretation in which the quantifier has wide scope over the modal verb is available.

1.7 Tests for ECM Constructions

In this section, I provide three arguments in favour of the claim that the embedded subject in (30a) has moved from a position inside the embedded CP into the object position in the matrix clause. These arguments are based on well attested syntactic differences between ECM constructions (see Davies and Dubinsky, 2004) such as (30a) and object Control constructions such as (30b):

- (30) a. John persuaded her to leave the room.
b. John believed her to have left the room.

There are fundamental differences in the characteristics of the DPs immediately following the matrix verbs in (30). While the object Control verb *persuade* in (30a) selects an internal argument (object DP *her*), the ECM verb *believe* in (30b) selects a TP whose subject is *her*. Therefore, the object of the Raising verb *believe* originates inside the infinitive and moves to the matrix object position. In addition, the embedded subject position of the ECM construction in (30b) is occupied by the unpronounced copy of the moved subject. In contrast, the embedded subject position of the object Control construction (30a) is filled by a *PRO* which is ‚controlled‘ by the antecedent DP in the matrix object position. Therefore in (30a), the matrix object DP *her* is base generated in the matrix clause as the argument of *persuade* and controls *PRO* in the embedded subject position. In contrast, in (30b), *her* is base-generated in the embedded clause as the argument of *leave* but moves from the infinitive into the object position in the matrix clause.

On the basis of these differences, certain tests can be derived that distinguish ECM from object Control structures. Since object Control predicates assign thematic roles to their objects, but ECM predicates do not assign thematic roles to their object positions, only ECM-predicates such as *believe*, but not object Control verbs like *persuade*, allow for expletives in the object position of matrix verbs:

- (31) a. John believes it to have rained.
b. John believes there to be a UFO in the backyard.

- (32) a. *John persuaded it to rain.
b. *John persuaded there to be a UFO in the backyard.

The fact that semantically empty elements like *it* and *there* can be objects of the verb *believe* in (31) indicates that *believe* in (31) does not assign a thematic role to its object. Consequently, *believe* must be an ECM verb. The subject of the embedded infinitive has received accusative case from matrix *v*, but instead of A-movement of the embedded subject to [Spec, *v*], the infinitival subject remains *in situ*, and the EPP-feature associated with matrix *v* is satisfied by the expletive *there*.

Another test that distinguishes ECM constructions from object Control constructions is based on the behaviour of idiomatic expressions:

- (33) a. John believed the cat to be out of the bag by now.
b. John persuaded the cat to be out of the bag.

The idiomatic reading is retained when the subject part of the idiom chunk in (33a) undergoes Raising from the embedded subject position to the matrix object position. In contrast, in the object Control construction in (33b), the idiomatic interpretation is not possible. While *the cat* can be understood as a secret in (33a), in (33b), the only possible meaning of *the cat* is a specific feline (Davies and Dubinsky, 2004).

ECM and object control constructions also differ in meaning when the complement clause is passivised:

- (34) a. John believes the professor to have taught Mary.
b. John believes Mary to have been taught by the professor.
- (35) a. John persuaded the professor to teach Mary.
b. John persuaded Mary to be taught by the professor.

In the ECM construction in (34), the embedded passive construction in (34b) is the truth-functional equivalent of the active construction in (34a). In contrast, the active and passive forms of the object control construction in (35) are not synonymous.

CHAPTER 2

Long subject-to-subject raising

This chapter is concerned with raising of a DP from the embedded subject position of a finite complement to the matrix subject position, an operation that I henceforth refer to as *Hyperraising* (cf. Ura, 1994). As discussed in chapter 1, in the MP, the analysis of Raising constructions operates on the assumption that Raising infinitives are defective clauses that lack a CP. Therefore, the embedded T-head cannot assign case to its subject. Due also to the absence of a CP in a defective clause, the non-defective matrix T is able to check the case features of the embedded subject via agreement. If there is no expletive in the numeration to check the EPP features of the matrix T, a copy of the embedded subject DP is merged into [Spec T] of the matrix clause in order to satisfy the EPP feature of the matrix T. It is therefore not expected that Hyperraising would ever be possible. First, if the embedded clause is finite, why does the subject have to raise and get nominative case from the matrix T? Second, how can case be assigned to an embedded subject DP by a case assigner in the matrix clause given that a CP intervenes?

In this chapter, I show that this expectation is contradicted by a vast number of languages. I present data from many genetically diverse languages that manifest Hyperraising out of finite complements. In section 2.1, I discuss languages in which Hyperraising is possible out of *subjunctive* complements. These data have given rise to the hypothesis that these complements are still in some sense “defective” and are therefore comparable to Raising infinitives in a language such as English. For example, one may argue that Raising is possible from subjunctive complements because subjunctive clauses are presumed to be temporally deficient (see e.g. Binnick (1991); Cowper (2002); Landau (2004); Boeckx and Hornstein (2006); Polinsky and Potsdam (2006) and chapter 4). However, the data I present in section 2.2 show that there are also many languages that allow Raising out of finite *indicative* complements. In section 2.3, I turn to Copy Raising and discuss languages in which Raising out of finite indicative complements leaves a resumptive copy in the embedded clause’s subject position. I also demonstrate that these Copy Raising-constructions differ from similar constructions in English and Swedish that at

first sight resemble (and have sometimes also been labelled) Copy Raising constructions. On the basis of empirical evidence from the occurrence of expletives, interpretation of idioms, long passivisation and scope, I show for each of the languages that I discuss here that the matrix subject originates as a thematic argument of the embedded finite predicate and has indeed moved from the embedded to the matrix subject position. While some of the relevant evidence, which is based on the tests that I introduced in chapter 1, is provided in the literature from which most of my data is adopted, I have, wherever possible, added data from my own fieldwork.

2.1 Hyperraising from finite subjunctive complements

2.1.1 Hyperraising in Greek

Soames and Perlmutter (1979) show that in Greek, predicates such as *fenome* ‘seem’, or *pioano* ‘likely’ trigger Hyper-Raising of an embedded subject DP to the matrix subject position:

- (1) a. Fenete [oti i kopeles θa fevgun]
 seem-3SG COMP the girls-NOM FUT leave
 ‘It seems that the girls will be leaving.’
- b. I kopeles fenonde [na fevgun]
 the girls- NOM seem-3PL SUBJ leave
 ‘The girls seem to be leaving.’

(Greek; Soames and Perlmutter, 1979: 156)

In both examples in (1), the verb *fenome* selects a finite clausal complement. In (1a), the clause is introduced by the indicative complementiser *oti*, while the complement of *fenome* in (1b) is introduced by the subjunctive complementiser *na*. In (1a), the thematic subject of the embedded clause is in the embedded subject position, which is shown by the fact that the DP *i kopeles* appears after the complementiser. In contrast, in (1b), the

DP *i kopeles* appears in the matrix subject position and shows person and number agreement with the matrix verb *fenonde*.

Soames and Perlmutter (1979) provide evidence that the matrix subject in (1b) has indeed undergone Hyperraising. For instance, Soames and Perlmutter show that, when the embedded verb of the matrix predicate *fenome* in (2) is passivised, the active and passive constructions are synonymous. The meanings of (2a) and (2b) are similar because the DP *mas/emis* is the internal argument of the embedded verb *nikun* in both sentences.

- (2) a. Afti fenonde [na mas nikun]
they seem-3PL SUBJ us defeat-3PL
„They seem to be defeating us.’
- b. Emis fenomaste [na nikyomaste apo aftus]
we seem-1PL SUBJ be-defeated-1PL by them
„We seem to be being defeated by them.’

(Greek; Soames and Perlmutter, 1979: 157)

Also, an idiomatic reading is preserved when a sentential idiom is embedded under *fenome* with the idiomatic subject occurring as the matrix subject:

- (3) a. Fenete [oti o kombos tha ehi ftasi sto hteni]
seem-3SG COMP the knot FUT has arrive at.the comb
„It seems that the knot has arrived at the comb.’ (Literal interpretation)
„It seems that things have come to a head.’ (Idiomatic interpretation)

- b. O kombos fenete [na ehi ftasi sto hteni]
 the knot seem-3SG SUBJ has arrive at the comb
 „The knot seems to have arrived at the comb.’ (Literal)
 „Things seem to have come to a head.’ (idiomatic)

(Greek; Soames and Perlmutter, 1979: 157)

That (3b) maintains its idiomatic reading despite the fact the subject of the idiom appears in the matrix subject position while the rest of the idiom is in the embedded clause is an indication that Raising has taken place. Idioms are treated as complex lexical units, and they must appear as syntactic units at some level of representation. Since the matrix subject *o kombos* can be interpreted as part of the embedded idiom, it must have originated as part of the same syntactic constituent – the embedded clause.

Alexiadou and Anagnostopoulou (1999) show that aspectual verbs such as *arxizi* ‚start’ and *stamatao* ‚stop’ in Greek also allow for their matrix subjects to be interpreted as the thematic arguments of their subjunctive clausal complements. The example in (4) provides additional evidence that these constructions are derived by movement of the embedded subject DPs out of their finite clauses to the matrix subject positions:

- (4) O eaftos tu arxizi [na tu aresi]
 the self his-NOM start-3SG SUBJ CL-GEN appeal-3SG
 „He starts liking/ accepting himself.’

(Greek; Alexiadou and Anagnostopoulou, 1999: 6)

Following Joseph (1976), Alexiadou and Anagnostopoulou (1999) present a language-specific test for Hyperraising in Greek that involves reflexivization. Greek reflexives are subject to Condition A, that is, a reflexive can only refer to an antecedent that is a clausemate. According to Alexiadou and Anagnostopoulou (1999), Greek has nominative anaphors such as *o eaftos* that can only occur with experiencer object predicates like

aresi. However, as (4) shows, nominative anaphors are also possible in the subject position of Raising verbs like *arxizo* when the embedded verb is an experiencer object predicate like *aresi*. (4) is grammatical despite the fact that the nominative anaphor *o eaftos* and the experiencer object predicate *aresi* are not within the same clause. The grammaticality of (4) therefore indicates that at some stage during the derivation of (4), the nominative anaphor must have been in the same clause as the experiencer object predicate before moving to the matrix subject position. Crucially, the matrix verb *arxizi* in (4) selects a finite complement in the subjunctive mood, as evidenced by the occurrence of the subjunctive marker *na* and overt agreement on the embedded verb *aresi*. This means that Greek is a language which clearly allows for Hyperraising, i.e. subject-to-subject Raising out of finite complement clauses.

2.1.2 Hyperraising in Japanese

Hyperraising is also found in Japanese, as illustrated by the examples in (15), quoted in Ura (1994):

- (5) a. Kyoo-no kaigi-de [karera-ga asita kuru to]
 today-GEN meeting-at they-NOM tomorrow come COMP
 houkokus-are-ta
 report-PASS-PAST
 ‚It was reported at today’s meeting that they would come tomorrow.’
- b. Karera-ga kyoo-no kaigi-de (Mary-niyotte) [asita kuru to]
 they-NOM today- GEN meeting-at Mary-by tomorrow come COMP
 houkokus-are-ta
 Report- PASS-PAST
 (lit.) ‚They were reported by Mary at today’s meeting that they would come tomorrow.’

(Japanese; Ura, 1994: 298)

In both examples in (5), the predicate *houkokus-are-ta* ‚was reported’ selects a finite complement introduced by the indicative complementiser *to*. Ura suggests that an

expletive *pro* occupies the matrix subject position in (5a) and therefore concludes that the subject position is a non- Θ -position and that the matrix verb is unaccusative. Any proper subject in the matrix clause is not an argument of the matrix verb and must have moved there, so *karera-ga* ‚they’ in (5b) is assumed to have moved from the embedded clause to the matrix subject position.

In the same vein, Uchibori (2000, 2001) provides evidence that the predicate *nat-ta* ‚happened’ triggers Hyperraising in Japanese. The complement clause in (6) is a finite CP in the subjunctive mood; it is introduced by the subjunctive complementiser *yooni*:

(6) John-ga saikin [motto benkyoosu-ru-yooni] nat-ta
 John-NOM recently more study-NONPAST-SUBJ happen-PAST
 (lit.) ‚It recently happened as a natural result that John studied harder.’

(7) [Siraha-no ya]-ga_i kinoo yatto [t_itekisetuna koohosya-ni
 white feather-GEN arrow-NOM yesterday finally appropriate candidate-DAT
 tat-u-yooni] nat-ta
 stand-NONPAST-SUBJ happen-PAST
 ‚Yesterday, it finally happened that an arrow made of white feather hit the
 appropriate candidates.’ (Literal interpretation)
 ‚Yesterday it finally happened that appropriate candidates were nominated as a
 natural consequence from the situation’ (Idiomatic interpretation)

(Japanese; Uchibori, 2001:146, 149)

Japanese Raising subjunctive complements, like regular Raising constructions, preserve idiomatic meanings as shown in (7). Despite the fact that part of the embedded idiom in (7) is part of the matrix clause, the idiom still retains its idiosyncratic meaning. This shows that at some stage of the derivation, the moved subject DP *siraha-noya-ga* ‚an arrow made of white feather’ was part of the embedded clause. The data from Uchibori (2000, 2001) hence demonstrate that Japanese allows Raising out of subjunctive complement CPs introduced with an overt complementiser *-yooni*.

2.1.3 Hyperraising in Zulu

It has been suggested by Zeller (2006a, b) that it is possible to raise a subject DP out of a finite subjunctive complement CP to the matrix subject position in Zulu in examples such as (8).

(8) a. Ku-fanele [ukuthi amadoda a-hamb-e manje.]
EXPL-ought that man6 SM6-leave-SUBJ now
'The men ought to leave now.'

b. Amadoda a-fanele [ukuthi a-hamb-e manje.]
man6 SM6-ought that SM6-leave-SUBJ now
'The men ought to leave now.'

(Zulu; Zeller 2006b: 1)

c. U-John u-zame [uku-fika ngesikhathi]
John1 SM-try INF-arrive on time
'John tried to arrive on time.'

d. *Ku-zame [ukuthi u-John afike ngesikhathi]
it tried that John1 arrive on time
'*It tried that John arrived on time.'

In both the expletive construction in (8a) and the Raising construction in (8b), the matrix verb *fanele* selects a finite complement introduced by an overt complementiser *ukuthi*, and both complements are in the subjunctive mood. In (8a), the thematic subject of the embedded clause is in the embedded subject position shown by the fact that the DP *amadoda* appears after the complementiser in (8a). In contrast, in (8b), the DP *amadoda* appears in the matrix subject position and agrees with the matrix verb *fanele* which shows noun class agreement with the subject DP. The ungrammaticality of (8d) shows that it is not possible to have the expletive-like element *ku* in the subject position of the Control verb *zame* 'try' because it selects a thematic external argument.

Zeller (2006b) presents a number of traditional as well as language-specific arguments for a Hyperraising analysis of the Zulu predicate *fanele* based on proven syntactic distinctions between Control and Raising constructions. First, the Zulu Raising verb *fanele* in (8) can accommodate an expletive as its subject whereas a Control verb cannot. According to Zeller (2006a), the occurrence of *ku* is usually an indication that there is an expletive subject in the matrix clause (typically, this would be an expletive *pro*, which triggers default agreement expressed by *ku*, unless one analyses the prefix *ku* itself as an expletive marker¹⁴). The fact that *ku* can occur before *fanele* is an indication that *fanele* is an unaccusative Raising verb which does not select an external thematic argument. Zeller (2006b) therefore argues that the matrix subject in (8b) has moved from the embedded subject position to the matrix subject position. In contrast, while the Control construction with the matrix subject DP *u-John* in (8c) is grammatical, its counterpart with the Zulu expletive *ku* in the matrix subject position (8d) is ungrammatical. This is because the Control verb *zame*, unlike the Hyperraising verb *fanele*, assigns a thematic role to its subject. Therefore, a semantically empty element like *ku* cannot appear in the subject position of Control predicates like *zame*.

A second piece of evidence that Raising has occurred is that when part of a Zulu idiom or proverbial expression occurs in the matrix clause, the idiomatic meaning is not lost. This is in contrast to what obtains in Control constructions:

- (9) a. Izandla zi-fanele [ukuthi zi-gez-an-e]
 hand8 SM8-ought that SM8-wash-REC-SUBJ
 ‚It’s vital that one hand washes another.’ (idiomatic)
- b. Izandla zi-thembis-a [uku-gez-an-a]
 hand8 SM8-promise-FV INF-wash-REC-FV
 ‚The hands promise to wash one another.’ (not idiomatic)

(Zulu; Zeller 2006b: 1)

¹⁴ See Harford (= Perez) (1997:117), Perez (1983, 1985), Bresnan and Kanerva (1988), Demuth (1990), Harford (1990) and others on the use of locative subject markers as expletives in Bantu languages.

The fact that (9a), like the Greek and Japanese examples in (3) and (7) above, preserves its idiomatic meaning, is an indication that *fanele* is a Raising predicate. In contrast, only the literal reading is available in the Control construction in (9b).

Third, Zeller (2006) observes that when the embedded verb of the Raising *fanele* is passivised, such that the embedded object becomes the matrix subject, the meaning of the passive sentence is similar to the active one. In contrast, when arguments of Control constructions are switched, there is no meaning similarity between the active and passive constructions:

- (10) a. Udokotela u-fanele [ukuthi a-bhek-e isiguli]
 doctor1a SM1a-ought that SM1a-examine- SUBJ patient7
 „The doctor must examine the patient.’
- b. Isiguli si-fanele [ukuthi si-bhek-w-e ng- udokotela]
 patient7 SM7-ought that SM7-examine-PASS-SUBJ by-doctor1a
 „The patient must be examined by the doctor.’
- c. Udokotela u-funa [uku-bhek-a isiguli]
 doctor1a SM1a-want-FV INF-examine-FV patient7
 „The doctor wants to examine the patient.’
- d. Isiguli si-funa [uku-bhek-w-a ng-udokotela]
 patient7 SM7-want INF-examine-PASS-FV by-doctor1a
 „The patient wants to be examined by the doctor.’

(Zulu; Zeller 2006b: 5)

Examples (10a) and (10b) are synonymous, indicating that *fanele* preserves the truth-functional equivalence when passivised. However, (10c) and (10d) are not synonymous, indicating that Zulu Control clauses do not preserve the truth conditions under passivisation. The difference between the behaviour of Raising and Control structures

under passivisation is linked to the fact that Control predicates have theta-marked external arguments while Raising predicates do not.

Fourth, Zeller (2006b) observes that in Zulu Raising constructions, the embedded object can have wide scope with regards to the matrix subject:

- (11) a. Othisha aba-bili ba-fanele [ukuthi ba-bhek-e wonke umfundi]
teacher2a RC2a-two SM2a-ought that SM2a-supervise-SUBJ every1 student1
„Two teachers must supervise every student.’
- b. Othisha aba-bili ba-zama [uku-bheka wonke umfundi]
teacher2a RC2a-two SM2a-try INF-supervise every1 student1
„Two teachers are trying to supervise every student.’

(Zulu; Zeller 2006b: 5)

(11a) has two possible interpretations because the matrix subject originates in the embedded clause. It could mean that there are two specific teachers who must supervise every student (= narrow scope of the embedded object). However, (11a) can also mean that it is necessary that every student be supervised by any two teachers (wide scope of embedded object). This reading is possible, because a quantified object can take scope over a quantifier subject, as long as both quantifiers are clausemates. Therefore, in the Control construction in (11b), the embedded object is only capable of a wide scope interpretation, because the subject originates in the matrix clause. The fact that the embedded object can take scope over the matrix subject in (11a) demonstrates that the two quantifiers must have been within the same clause at some stage of the derivation, which in turns shows that *fanele* has attracted the embedded subject to move to its subject position.

A fifth argument put forward by Zeller (2006b) to distinguish between Control and Raising construction in Zulu has to do with the fact that Zulu allows V-S word order with

Control predicates which select clausal complements, (12a). This implies that the matrix subject in the Control example has remained inside the vP/VP. However, (12b) shows that in the *fanele* Raising construction, the matrix subject cannot intervene between *fanele* and the complementiser, which means that it cannot occupy the [Spec, v] position of the matrix clause. This in turn follows from the assumption that the matrix subject of *fanele* originates in the embedded clause and raises directly to the specifier of the head with which it has entered an Agree-relation, i.e. matrix [Spec, T]. Since matrix [Spec, v] is not a possible landing site for A-movement, the ungrammaticality of (12a) is expected.

- (12) a. Ku-thembis-a uJohn [ukuthi u-zo-fika namhlanje.]
 EXPL-promise-FV John1a that SM1a-FUT-arrive-FV today
 ‚John promises that he will arrive today.’
- b. *Ku - fanele abantwana [ukuthi ba-dlal-e ngaphandle.]
 LOC-ought child2 that SM2-play-SUBJ outside
 ‚The children must play outside.’

(Zulu; Zeller 2006b: 6)

In sum, the data discussed in Zeller (2006a, b) show that the modal verb *fanele* in Zulu triggers Hyperraising out of subjunctive clausal complements.

2.1.4 Hyperraising in Rumanian

According to Grosu and Horvath (1984), Rumanian also has certain predicates which trigger the movement of a subject DP from an embedded finite subjunctive complement to the matrix subject position:

- (13) a. S-a nimerit [ca toți băieții să fie bolnavi]
 REFL have.PRES.3SG happened that all the boys SUBJ PRT be sick
 ‚It happened that all the boys were sick.’

- b. Toti băieții s-au nimerit [să fie bolnavi]
 all the boys REFL.have.PRES.3PL happened SUBJ PRT be sick
 ‚All the boys happened to be sick.‘

(Rumanian; Grosu and Horvath, 1984: 351)

In (13a), the verb *nimerit* ‚happen‘ selects a finite complement clause which is introduced by the subjunctive complementiser *ca*. In (13a), the thematic subject of the complement clause is located in the embedded subject position, as is demonstrated by the fact that the DP *toți băieții* ‚all the boys‘ follows the complementiser *ca* in (13a). In contrast, in (13b), the DP *toți băieții* occurs in the matrix subject position and agrees with the matrix verb *s-au nimerit* ‚have happened‘, which now shows overt agreement with the subject DP. Consequently, a plausible assumption is that the matrix subject in (13b) has moved from the embedded subject position to the matrix subject position.

Like other Raising predicates, the Rumanian Raising predicate *a se nimerit* can take an expletive in its subject position. Rumanian, being a pro-drop language, licenses expletive *pro* in its subject position (Grosu and Horvath 1984: 349). The fact that a null expletive may appear in the matrix subject position in (13a) is an indication that the subject position of *nimerit* is a non-thematic position and *nimerit* does not assign an external theta role to its subject. This suggests that the example in (13) is indeed reminiscent of Hyperraising in Greek, Japanese and Zulu, where an embedded subject DP is raised out of a subjunctive complement to the matrix subject position.

Notice that, although the embedded verb in (13b) is still finite, the overt complementiser *ca* that introduces the subjunctive complement in (13a) does not appear. In fact, Grosu and Horvath (1984) observe that the appearance of the overt complementizer *ca* in the Raising Construction in (13b) renders the sentence ungrammatical:

- (14) *Toți băieții s-au nimerit [ca să fie bolnavi]
 all the boys REFL.have. PRES.3PL happened SUBJ SUBJ PRT be sick
 ‚All the boys happened to be sick.’

(Rumanian; Grosu and Horvath, 1984: 351)

(14) therefore shows that in Rumanian, Raising of an embedded subject DP can only occur out of a subjunctive CP in the absence of an overt complementiser. This observation will be relevant for the theoretical analysis of long A-movement constructions that I offer in chapter 6.

2.1.5 Hyperraising in Persian

Darzi (1993) observes that in Persian, verbs and adjectival predicates like *næzær* ‚seem’, *lazem budæn* ‚be necessary’, *bæ?id budæn* ‚unlikely’, and *momken budæn* ‚be possible’ cause Hyperraising as illustrated in (15):

- (15) a. (In) lazem æst [ke æli ketab-ra be hæšæn be-dæh-æd]
 (it) necessary is that Ali book-ACC to hassan SUBJ-give-3SG
 ‚It is necessary that Ali gives the book to Hassan.’
- b. æli lazem æst [ke ketab-ra be hæšæn be-dæh-æd]
 Ali necessary is that book-ACC to Hassan SUBJ-give-3SG
 ‚Ali is required to give the book to Hassan.’

(Persian; Darzi, 1993: 82)

In both examples in (15), the predicate *lazem* picks a finite clause as its complement. This clause is introduced by the (optional) complementiser *ke* and appears in the subjunctive mood. In (15a), the thematic subject of the subordinate clause is located in the embedded subject position as shown by the fact that the DP *Ali* follows the complementiser in (15a). In contrast, in (15b), the DP *Ali* appears in the matrix subject position; an indication that the subject DP *Ali* has undergone Raising out of the finite embedded clause of *lazem* into the matrix clause.

Darzi (1993) provides a number of arguments based on syntactic differences between typical Raising constructions and subject Control constructions to prove that the lexical subject in (15b) has moved into the matrix clause from a position inside the embedded CP. Note that a Control-analysis may at first sight also look plausible: since certain languages allow for Control constructions with finite subjunctive complements, it cannot *a priori* be excluded that the matrix subject *æli* in (15b) is perhaps an argument of the matrix verb and Controls a PRO-subject in the embedded subject position.

However, Darzi's arguments rule out a Control-interpretation. First, Darzi (1993) observes that while expletives may be inserted in the subject position of Persian Hyperraising predicates, as illustrated by the example in (15a), Control predicates do not allow expletives in their subject position because in contrast to Hyperraising predicates, Control predicates assign an external theta role to their subject. Compare (15a above) and (16):

- (16) *In sæ?y mi-kon-æd [un kampiyuter xeili geran ba]-æd]
 it try IND-do-3SG that computer very expensive be-3 SG
 *,„That computer tries to be very expensive.’

(Persian; Darzi, 1993: 84)

The second argument is that in Persian Hyperraising constructions involving the predicate *momken* ‚possible’, a quantifier in the matrix clause is capable of taking both narrow and wide scope interpretations with respect to the modal Raising verb, (17a). In contrast, subject main clause quantifiers in Control constructions can only have the wide scope reading, (17b):

- (17) a. Kæsi momken æst [u-ra be]-æns-æd]
 someone possible is he-ACC IND-know-3SG
 i. „It is possible that there is someone X, such that X knows him.’
 (Narrow scope)

ii. „There is someone X, such that it is possible that X knows him.’
 (Wide scope)

b. Kæsi mi-xah- æd [dær in mowred sohbæt kon-æd]
 someone IND -want-3SG about this issue talk do-3SG
 „There is someone X, such that X wants to talk about this issue.’

(Persian; Darzi, 1993: 84)

On standard assumptions, narrow scope of the subject quantifier in (17a) can only be available if the quantifier is syntactically in the scope of the modal verb at some stage of the derivation. If (17a) is derived by Hyperraising, then the possibility of this scope reading is expected, since the quantifier has indeed originated inside the embedded clause. In contrast, the quantifier in (17b) is an external argument of the modal verb and therefore (presumably) not C-commanded by it at any relevant stage of the derivation.

The third argument provided by Darzi (1993) has to do with selectional restrictions. In Persian, Hyperraising predicates like *be næzær mi-res- æd* „seem’ do not impose selectional restrictions on their subjects, because they do not theta-mark them. In contrast, Control predicates theta-mark and select the properties of their external arguments:

(18) a. Zæmin be næzær mi-res- æd [ke hærekkæt mi-kon-æd]
 earth to view IND-reach-3SG that movement IND-do-3SG
 „The earth seems to move.’

b. *Zæmin sæ?y mi-kon-æd-ø [ke hærekkæt be-kon-æd]
 earth try IND-do-3SG that movement SUBJ-do-3SG
 *„The earth tries to move.’

(Persian; Darzi, 1993: 84)

Darzi (1993) observes that the Hyperraising construction in (18a) is grammatical and semantically well-formed because the inanimacy of the subject of the Raising predicate does not matter, since Raising predicates do not impose selectional restrictions on their subjects. In contrast, the Control construction in (18b) is semantically ill-formed. The oddness in (18b) stems from the semantic requirements of ‚try‘. The verb ‚try‘ assigns an agent role to its subject which requires an entity that is capable of volition. Inserting an inanimate DP like *zæmin* in the subject position of the Control verb *sæ?y* ‚try‘ therefore violates the selectional restriction of the Control verb. The contrast in (18) clearly identifies this and the related constructions above as Hyperraising constructions.

Finally, Darzi (1993) observes that in Persian, when part of an embedded sentential idiom is moved to the subject position of a Hyperraising predicate like *be næzær mi-res-æd* ‚seem‘, the idiom retains its idiomatic interpretation as illustrated in (19):

- (19) a. *Be næzær mi-res-æd* [ke tæ]t-e-u æz bam oftad-e]
 to view IND-reach-3SG that bathtub- he from roof fall
 ‚It seems that his bathtub has fallen from the roof.‘ (Literal interpretation)
 ‚It seems that he has been scandalized.‘ (Idiomatic interpretation)
- b. Tæ]t-e-u be næzær mi-res-æd [ke æz bam oftad-e]
 bathtub-he to view IND-reach-3SG that from roof fall
 ‚He seems that his bathtub has fallen from the roof.‘ (literal interpretation)
 ‚He seems to have been scandalized‘ (idiomatic interpretation)

(Persian; Darzi, 1993: 83)

To sum up this section, a large number of typologically diverse and unrelated languages show Hyperraising out of finite subjunctive clauses. The tests provided show clearly that the subjects that appear in the matrix clauses of these complex constructions originated inside the embedded clauses and therefore must have crossed a finite CP-node when moving to their final landing site [Spec, T].

2.2 Hyperraising from finite indicative complements

2.2.1 Hyperraising in Bantu

Hyperraising is not only possible from subjunctive complements; it has also been shown to occur out of finite *indicative* CPs. To my knowledge, the first detailed study of this type of Hyperraising construction in Bantu was presented by Perez (1985) in her analysis of Shona, Kiruúndi, and Kikuyu:

(20) a. Vy-aa-menyeeekan-ye [kó inzovu z-iish-é báa-ba-antu]
SM8-PAST-be.known-PERF that elephant10 SM 10-kill- PERF DEM2-people2
,,It is well known that elephants have killed those people.’

b. Inzovu z-aa-menyeeekan-ye [ko z-iish-e báa-ba-antu]
elephant10 SM10-PAST-be.known-PERF that SM10-kill-PERF DEM2-people2
,,Elephants are renowned for having killed those people.’

(Kiruúndi; Perez 1985: 2-4)

(21) a. Zví-no-fungir-w-a [kuti mbavhá y-aka-vánd-á múbako]
SM8-PRES-suspect-PASS-FV that thief9 SM9- PAST-hide-FV in. cave
,,It is suspected that the thief is hidden in the cave.’

b. Mbavha i-no-fungir-w-a [kuti y-aka-vand-a mubako]
Thief9 SM9-PRES-suspect-PASS-FV that SM9-PAST-hide-FV in. cave
,,The thief is suspected to be hidden in the cave.’

(Shona; Perez 1985: 2-4)

(22) a. Kũ-ũĩkáíne [atĩ mũ-ndũ-mũ-rũme ũ-yũ óórág-íré mũ-ndũ]
SM17-has been known that PERS1-man1 this1 SM1-kill-PAST PERS1
,,It is known that this man killed a person.’

- b. Mũ-ndũ-mũ-rũme ũ-yũ ní óóíkáine
 PERS1-man1 this-1 FOC SM1-has been known
 [átĩ nĩ óórág-íre mũ-ndũ]
 that FOC SM1-kill-PAST PERS1
 ‚This man is known to have killed a person.‘

(Kikuyu; Perez, 1985: 2-4)

In the examples (20)-(22), all the matrix verbs select finite indicative CPs with overt complementisers. The embedded T-heads are overtly marked for both agreement and tense. In the (a)-examples, the thematic subjects of the embedded clauses (*inzovu*, *mbavha*, and *mũ-ndũ-mũ-rũme* respectively) appear in the embedded subject position, as is illustrated by the fact that these subjects follow the overt complementisers. In contrast, in the (b)-examples, these DPs appear in the matrix subject positions, and the matrix verbs show noun class agreement with these DPs. These data suggest that the matrix subjects in the (b)-examples have undergone Hyperraising.

Perez (1985) shows that the matrix subjects of the sentences in (20b), (21b), and (22b) are not arguments of the matrix verbs. The matrix verbs in the (a)-examples do not select external arguments. Rather, it is assumed that the matrix subject position is filled with an expletive *pro* which triggers default agreement with the matrix verb. Default agreement can be expressed by means of a locative noun class prefix, as in Kikuyu (compare also the Zulu data with *fanele* and class 17 *ku-* discussed in section 2.2.3), or it can be borrowed from noun class 8, as in Shona and Kiruúndi. The presence of default agreement indicates that the matrix subject position is a non- Θ -position and that the matrix verb is unaccusative. In contrast, in the examples in (20b)-(22b), the thematic subject DP of the embedded clauses appears in the matrix [Spec, T]-position and agrees with both the embedded and the matrix verbs. This suggests that the matrix subjects in (20b)-(22b) have moved into the main clause, and that (20b)-(22b) constitute examples of Hyperraising in Shona, Kikuyu, and Kiruúndi.

My own fieldwork on Shona, Kiruúndi and Kikuyu supports this conclusion. First, consider Shona. The matrix verb in the Shona example in (21) provided by Perez (1985)

is a passivised ECM-verb. But note that the unaccusative Raising verb *a-no-it-a* ‚seem’ also triggers movement of the embedded subject DP to the matrix subject position in Shona:

- (23) a. Zvi-no-it-a [sekuti Vimbai a-ka-ziya]
 SM8-PRES-seem-FV that Vimbai SM1-PRES- hungry
 ‚It seems that Vimbai is hungry.’
- b. Vimbai a-no-it-a [sekuti a-ka-ziya]
 Vimbai SM1-PRES-seem-FV that SM1-PRES-hungry
 ‚Vimbai seems to be hungry.’

In both the expletive construction in (23a) and in the Raising construction in (23b), the matrix verb *a-no-it-a* selects a finite complement introduced by the overt complementiser *sekuti*, and both complements are in the indicative mood. In (23a), the thematic subject of the embedded clause is in the embedded subject position, since the DP *Vimbai* appears after the complementiser in (23a). In contrast, in (23b), the DP *Vimbai* appears in the matrix subject position and agrees with the matrix verb *a-no-it-a* which shows noun class agreement with the subject DP.

Importantly, the idiomatic interpretation of a sentential idiom is maintained when its subject-part is raised in a Hyperraising construction involving *a-no-it-a*:

- (24) a. Zvi-no-it-a [sekuti hapwa ya-fumur-wa]
 SM8-PRES-seem-FV that armpit⁹ SM9-open-PAST
 ‚It seems that the armpit has opened.’ (Literal interpretation)
 ‚It seems that the secret has been revealed.’ (Idiomatic interpretation)
- b. Hapwa i-no-it-a [sekuti (iyo) ya-fumur-wa]
 armpit⁹ SM9-PRES-seem-FV that (it) SM9-open-PAST
 ‚The armpit seems to have been opened.’ (Literal interpretation)
 ‚The secret seems to have been revealed.’ (Idiomatic interpretation)

That (24b) maintains its idiomatic reading despite the fact the subject of the idiom appears in the matrix subject position while the rest of the idiom is in the embedded clause is an indication that Raising has taken place. Recall that idioms are treated as phrasal lexical units and at some stage of the derivation must have a representation as a syntactic unit. Since the matrix subject *hapwa* ‚armpit’ can be idiomatically linked to the embedded predicate, it must have originated as the subject of the embedded clause.

Other tests also support the conclusion that Shona has Hyperraising out of indicative clauses. When the embedded verb of the matrix predicate *a-no-it-a* is passivised, the active and passive constructions are synonymous. The active and passive constructions in (25) are similar because the DP *Mary* is the internal argument of the embedded verb *nikun* in both sentences:

- (25) a. John a-no-it-a [sekuti a-no-da Mary]
 John SM1-PRES-seem-FV that SM1-PRES-love Mary
 ‚John seems that he loves Mary.’
- b. Mary a-no-it-a [sekuti a-no-di-w-a na John]
 Mary SM1-PRES-seem-FV that SM1-PRES-love-PASS-FV by John
 ‚Mary seems that she is loved by John.’

In contrast, infinitival control constructions in Shona do not show this kind of semantic similarity between active and passive constructions, as expected:

- (26) a. John a-ka-edz-a [ku-ongoror-a mwana]
 John SM1-PAST-try-FV INF-examine-FV baby
 ‚John tried to examine the baby.’
- b. ?Mwana a-ka-edz-a [ku-ongoror-w-a na John]
 baby SM1-PAST-try-FV INF-examine-PASS-FV by John
 ‚The baby tried to be examined by John.’

The data in (25) and (26) clearly show that Shona is indeed a language which permits the thematic subjects of embedded indicative clauses to escape their CPs and undergo long A-movement into the matrix subject position.

Next, consider Kiruúndi. (27) shows Hyperraising constructions with the verb *kuboneka* ‚seem‘:

(27) a. Bi-bonek-a [ko Yohani a-ri umubeshi]
 SM8-seem-FV that John SM1-be liar
 ‚It seems that John is a liar.‘

b. Yohani a-bonek-a [ko a-ri umubeshi]
 John SM1-seem-FV that SM1-be liar
 ‚John seems to be a liar.‘

The examples in (27) mirror the Shona example in (23). In both the expletive construction in (27a) and in the Raising construction in (27b), the matrix verb *kuboneka* selects a finite complement introduced by an overt complementiser *ko*. Both complements are in the indicative mood. In (27a), the thematic subject of the embedded clause *Yohani* follows the complementiser and is hence in the embedded subject position. In contrast, in (27b), the DP *Yohani* appears in the matrix subject position and shows noun class agreement with the matrix verb *a-boneka*.

Again, I tested whether (27b) does indeed involve Hyperraising by constructing examples with embedded idioms. (28) shows that when part of a Kiruúndi idiom occurs in the matrix clause, the idiomatic meaning is maintained:

(28) a. Bi-bonek-a [ko a-a-n-ses-i-e agatabi]
 SM8-seem-FV that SM1-REC.PAST-OM-spill- PAST-FV tobacco
 ‚It seems that he spilled my tobacco.‘ (Literal interpretation)
 ‚It seems that he revealed my secret.‘ (Idiomatic interpretation)

- b. Agatabi ka-n-je ka-boneka [ko ka-a-ses-i-e]
 tobacco POSS-OM SM12-seem-FV that SM12- REC.PAST spill- PAST-FV
 ‚My tobacco seems to be spilled.‘ (Literal interpretation)
 ‚My secret seems to be revealed.‘ (Idiomatic interpretation)

Another indication that *kuboneka* triggers Hyperraising is that sentences like (29) below in which the complement has been passivised are semantically similar to those in which it has not:

- (29) a. Yohani a-bonek-a [ko a-á-fash-i-ye Maria]
 John SM1-seem-FV that SM1- PAST-help-PAST Maria
 ‚John seems to have helped Maria.‘
- b. Maria a-bonek-a [ko a-á-fash-i-u-ye na Yohani]
 Maria SM1-seem-FV that SM1-PAST-help-PASS-PAST by John
 ‚Maria seems to have been helped by John.‘

Kiruúndi behaves therefore like Shona in showing clear evidence for Hyperraising.

Finally, the same conclusion can be drawn for Kikuyu: Hyperraising is possible with Kikuyu verbs like *-onekana*:

- (30) a. Kũ-ro-nekana [atĩ mũ-ndũ-mũ-rũme ũ-yũ óórág-íré mũ-ndũ]
 SM17-ASP-appears that PERS1-man1 this1 SM1-kill-PAST PERS1
 ‚It appears that this man killed a person.‘
- b. Mũ-ndũ-mũ-rũme ũ-yũ aro-nekana [átĩ nĩ óórág-íre mũ-ndũ]
 PERS1-man1 this-1 SM1-appear that FOC SM1-kill- PAST PERS1
 ‚This man appears to have killed a person.‘

(30a) is the expletive construction while (30b) is the Hyperraising construction. In both constructions, the matrix verb *-onekana* selects a finite indicative complement introduced

by an overt complementiser *átĩ*. In (30a), the thematic subject of the embedded clause is in the embedded subject position, since *mũ-ndũ-mũ-rũme ũ-yũ* appears after the complementiser in (30a). In contrast, in (30b), the DP *mũ-ndũ-mũ-rũme ũ-yũ* occurs in the matrix subject position and agrees with the matrix verb *aro-nekana* in noun class.

Again, the idiom-test and the passivisation test both confirm that the construction (30b) in Kikuyu is an instance of long A-movement. In (31b), the subject part of the idiom in (31a) is moved from an embedded finite clause into the matrix subject position of the Raising predicate, and the idiom retains its idiomatic interpretation:

- (31) a. Kiara kimwe gi-ti-uragaga ndaa
 finger7 one SM7-NEG-kill louse
 ‚One finger cannot kill a louse.‘ (Literal interpretation)
 ‚One person cannot achieve much.‘ (Idiomatic interpretation)
- b. Kiara kimwe kiro-nekana [(ati) gi-ti-uragaga ndaa]
 finger7 one SM7-appear (that) SM7-NEG-kill louse
 ‚One finger appears to be unable to kill a louse.‘ (Literal interpretation)
 ‚One person appears to be unable to achieve much.‘ (Idiomatic interpretation)

Furthermore, when the embedded verb inside the complement clause of the Raising verb *-onekana* is passivised, such that the embedded object becomes the matrix subject, the meaning of the passive sentence is similar to the active one:

- (32) a. Mami a-ro-nekana [ati ni-a-rugire irio]
 Mother SM-PRES-appear that FOC- SM-cook-PAST meal
 ‚Mother appears to have cooked the meal.‘
- b. Irio i-ro-nekana [ati ni-i-rugir-w-o ni mami]
 meal SM-PRES-appear that FOC- SM-cook-PASS-PAST by mother
 ‚The meal appears to have been cooked by mother.‘

In sum, my own fieldwork has provided additional empirical evidence that the languages examined and discussed in Perez (1985) indeed show Hyperraising out of finite indicative clauses.

Staying with the Bantu languages, Harford (Perez) (1997) also provides evidence that Hyperraising exists in the Bantu language Kitharaka:

(33) a. í-kw-ìy-ìk-èèn-è
 PR-SM17-know-ST-REC/PERF-FV
 [àtì mù-ntù ù-yù n-áá-ìj-ìrè m-bùri]
 that 1PERS this-1 PR-SM1-steal-PAST-FV 10-goat
 ‚It is known that this person stole goats.’

b. Mù-ntù ú-yú n-áá -ìy-ìk-èèn-è
 1PERS this-1 PR-SM1-know-ST-REC/PERF-FV
 [àtì n-áá-ìj-ìrè m-bùri]
 that PR-SM1-steal-PAST-FV 10-goat
 ‚This person is known to have stolen goats.’

(Kitharaka; Harford (Perez), 1997: 113)

In (33b) again, the embedded subject seems to have raised to the matrix subject position of the passivised ECM-verb *ìyikèènè*. Harford (Perez) (1997) provides evidence in support of a Hyperraising analysis of this Kitharaka example. Again, the evidence is from idioms, such as the one in (34a). When the subject-part of this idiom in Kitharaka is raised from an embedded clause to the matrix subject position of *kũiyĩkana*, the idiomatic meaning is preserved, (34b):

- (34) a. kī-rīmo i-kĩ-a-mer-ir-i-e mu-ntũ ũ-yũ
 7-animal PR-SM.7-RPST-swallow-PAST-VS-FV 1-PERS this-1
 „The ‚kirimo’ swallowed this person.’ (Literal interpretation)
 „This person has completed the first stage of initiation.’ (Idiomatic interpretation)
- b. kī-rīmo i-kĩ-iy-ĩk-een-e
 7-animal PR-SM.7-know-ST-REC/PERF-FV
 atĩ i-kĩ-a-mer-ir-i-e mu-ntũ ũ-yũ
 that PR-SM.7-RPST-swallow-PAST-VS-FV 1-PERS this-1
 „The ‚kirimo’ is known to have swallowed this person.’ (Literal interpretation)
 „This person is known to have completed the first stage of initiation.’ (Idiomatic interpretation)

(Kitharaka; Harford (Perez), 1997: 117)

Finally, it has been noted by Zeller (2006d) that Zulu also has Raising out of embedded indicative clauses. In (35), the matrix verb is again a passivised ECM-verb, which in (35b) has attracted the thematic subject of the embedded indicative complement to move to the matrix subject position. In this position, *isela*, ‚thief’ now triggers noun class 5-agreement with the Raising predicate:

- (35) a. ku-sol-w-a [ukuthi isela li-zo-tshontsha-a imoto]
 LOC-suspect-PASS-FV that thief5 SM5-FUT-steal-FV car9
 „It is suspected that the thief will steal the car.’
- b. Isela i-sol-wa [ngokuthi li-zo-tshontsh-a imoto].
 thief5 SM5-suspect-PASS-FV that SM5-FUT-steal-FV car9
 „The thief is suspected to steal the car.’

(Zulu; Zeller 2006d, ex. (45) & (46))

Although Zeller does not provide any tests to show that (35b) is a genuine example of Hyperraising, the parallel between (35b) and the previously discussed examples from other Bantu languages is striking and suggest that we are indeed dealing with Hyperraising out of an indicative complement. It is noteworthy, however, that the form of the complementiser changes in the Hyperraising construction in (35b). I return to a discussion of those examples where Hyperraising changes the form of the embedded complementiser, or eliminates it entirely (as was found above to be the case in Rumanian), in my analysis in chapter 6. For now, it is crucial to conclude that Hyperraising out of indicative clausal complements is definitely not an isolated phenomenon, but seems to occur regularly, and in many different Bantu languages.

2.2.2 Hyperraising in Turkish

Following Aissen (1974), Pullum (1975), Kornfilt (1977), and George and Kornfilt (1981), Moore (1998) suggests that in Turkish, it is generally assumed that Hyperraising of an embedded subject DP is possible from finite indicative complements whose T-heads have tense/aspect morphology, but only if these complements lack agreement morphology:

- (36) b. Herkes [biz viski-yi iç-iyor-uz] san-iyor-Ø
 everybody-NOM we-NOM whiskey-ACC drink-PROG-1PL believe-PROG-3SG
 ‚Everybody believes we are drinking the whiskey.’
- c. *Biz [viski-yi iç-ti-k] san-il-iyor-uz
 we-NOM whiskey-ACC drink-PAST-1PL believe-PASS- PROG-1PL
 ‚We are believed to have drunk the whiskey.’

(Turkish; Moore, 1998: 153, 156)

In (36b), the embedded T-head has both tense and agreement morphology, and as expected, the embedded subject *biz* ‚we’ is assigned nominative case. In contrast, in (36c), the matrix predicate is a passivised ECM predicate that selects a complement whose T-head is overtly marked for both tense and agreement. However, contrary to

expectation, the embedded subject *biz* moves to the matrix subject position and the sentence is ungrammatical. Moore (1998), following George and Kornfilt (1981), therefore assumes that the ungrammaticality of (36b) is an indication that DP-movement out of complements with tense and agreement morphology is prohibited in at least some dialects of Turkish. (36) suggests that Hyperraising is not possible in Turkish from finite indicative complements whose T-heads are overtly marked for both tense/aspect and agreement. Consequently, it is assumed that in Turkish, agreement is what determines finiteness and by extension, case assignment and opacity/transparency of complement clauses.

However, Moore (1998:160) observes that in some dialects of Turkish, Raising of an embedded subject DP is possible from both types of finite indicative complements, as illustrated in (37):

- (37) a. san-a [biz süt-ü iç-ti-ler] gibi gel-di-Ø
 you-DAT we-NOM milk-ACC drink-PAST-3PL like seem-PAST-1PL
 „It seemed to you that we drank the milk.’
- b. Biz san-a [süt-ü iç-ti] gibi gel-di-k
 We-NOM you-DAT milk-ACC drink-PAST like seem-PAST-1PL
- c. Biz san-a [süt-ü iç-ti-k] gibi gel-di-k
 We-NOM you-DAT milk-ACC drink-PAST-1PL like seem-PAST-1PL
 „We seem to you to have drunk the milk.’

(Turkish; Moore, 1998: 162)

In the example in (37a), the embedded verb is overtly marked for both tense and agreement and the thematic subject *biz* of the embedded clause appears in the embedded subject position with its nominative case valued while the matrix subject position is occupied by a null expletive subject (Moore, 1998:154). The embedded clause in (37b) has a T-head that is overtly marked for tense but has no agreement morphology. In

contrast, the T-head of the embedded clausal complement in (37c) is overtly marked for both tense and number agreement with the matrix subject. In both (37b) and (37c), it is assumed that the matrix subject is the thematic subject of the embedded clause but has moved to the matrix subject position. Consequently, it also triggers person and number agreement on the matrix verb. (37c) is therefore another instance of Hyperraising out of an indicative complement clause.

Moore (1998) provides two pieces of evidence that predicates like *gibi gel* ‚seem‘ do indeed trigger Hyperraising from the embedded subject position. The first argument is that when the embedded predicate of the Turkish Raising verb *gibi gel* is passivised, both the active and passive constructions are synonymous as in (38) (note that in Turkish, 3rd person agreement morphology is marked by a zero-affix).:

- (38) a. Doktor ban-a [sen-i muayene et-miş-Ø] gibi gel-di-Ø
 doctor-NOM I-DAT you-ACC examination do-EVID-3SG like seem-PAST-3SG
 ‚The doctor seems to me to have examined you.‘
- b. Sen ban-a [doktor tarafından muayene ed-il-miş-sin]
 you-NOM I-DAT doctor by examination do-PASS-EVID-2SG
 gibi gel-din-n
 like seem-PAST-2SG
 ‚You seem to me to have been examined by the doctor.‘

(Turkish; Moore, 1998: 163)

The active (38a) and passive (38b) pair in (38) are synonymous. The DP *sen* ‚you‘ is the internal argument of the embedded verb *muayene* in the active and passive constructions. This is an indication that the DP *sen* already received its theta role in the embedded clause before moving to the matrix subject position. It is also an indication that the matrix predicate does not assign an external theta role.

The second piece of evidence has to do with the incompatibility of Hyperraising predicates like *gibi-gel* with passive morphology. Like unaccusative predicates in most

languages, *gibi-gel* does not select an external argument; therefore, it cannot be passivised:

- (39) a. *Dün akşam saat 10-da [çocuk süt-ün-ü iç-miş]
 yesterday evening O'clock 10-LOC child milk-3SG-ACC drink-EVID
gibi görün-ül-dü-Ø
 like appear-PASS-PAST-3SG
 ‚Yesterday evening at 10.00, it appeared that the child drank his/her milk.‘
- b. [Araba kullan-ma-k] öner-il-di-Ø
 car drive-PT.AT-1SG suggest-PASS-PAST-3SG
 ‚It was suggested that I drive a car.‘

(Turkish; Moore, 1998: 166)

Moore (1998) argues that, on the assumption that unaccusative predicates lack an external theta role and are not expected to undergo passivisation, the ungrammaticality of (39a) suggests *gibi gel* is indeed an unaccusative predicate. *gibi gel* does not assign an external theta role and can therefore not undergo passivisation. This suggests that the subject DP which occupies the matrix subject position of this verb in examples such as (37b) and (38) is not an argument of the matrix verb, which implies that it has moved to the subject position. In contrast, the matrix predicate *öner* ‚suggest‘ in (39b) selects an external argument, and consequently can undergo passivisation and is compatible with passive morphology. This shows that the ungrammaticality of (39a) is in fact caused by the unaccusativity of the matrix predicate, and not due to some independent constraint.

2.2.3 Hyperraising in Brazilian Portuguese

Rodrigues (2004) discusses the following examples from Brazilian Portuguese:

- (40) a. E parece [que a Maria está doente]
 seem-3SG that the Maria is-3SG sick
 ‚It seems that Maria is sick.‘

- b. A Maria parece [que está doente]
 the Maria seem-3SG that is-3SG -PRES sick
 „It seems that Maria is sick.”

(Brazilian Portuguese; Rodrigues, 2004: 118)

The embedded clauses in (40) are both finite indicative CPs with an overt complementiser *que* and embedded verbs with tense and agreement morphology. In the example in (40a), the thematic subject *a Maria* of the embedded clause appears in the embedded subject position as evidenced by the fact that the subject DP follows the overt complementiser *que*. In contrast, in (40b), the DP *a Maria* appears in the matrix subject position and triggers agreement with both the embedded verb and with the matrix predicate *parece* „seem’. Again, (40b) is consistent with a Hyperraising analysis, according to which the embedded subject DP *a Maria* has moved from the embedded subject position across the finite CP-node into the matrix [Spec, T] position.

Martins and Nunes (2006) provide the now familiar type of evidence that examples such as (40b) from Brazilian Portuguese are indeed derived by Hyperraising. (41b) shows that when the subject part of an embedded sentential idiom appears in a matrix clause with a predicate like *parece*, the idiomatic reading is preserved:

- (41) a. A vaca foi pro brejo
 the cow went to-the swamp
 „The cow went to the swamp.’ (Literal interpretation)
 „Things went bad.’ (Idiomatic interpretation)
- b. A vaca parece que foi pro brejo
 the cow seems that went to-the swamp
 „The cow seems to have gone to the swamp.’ (Literal interpretation)
 „It seems that things went bad.’ (Idiomatic interpretation)

(Brazilian Portuguese; Martins and Nunes, 2006:17)

Examples such as (41b) show that the constructions discussed here do indeed involve subject-to-subject Raising of an embedded DP across a CP-node.

An analysis along these lines has been suggested by Ferreira (2000). Ferreira argues that Brazilian Portuguese has two types of finite indicative clauses, one which is defective, and one which has a complete set of Agree features. According to Ferreira, the embedded complement CP in (40b) is defective. Consequently, the defective ϕ -features of the embedded T-head are unable to value and delete the case feature of the embedded subject DP. Therefore, this DP enters an Agree-relation with the matrix T and undergoes Hyperraising to the matrix subject position.

As also pointed out by Rodrigues (2004), Ferreira's (2000) argument is not well motivated, considering that the complement of the expletive variant in (40a) has the same morphological properties as the complement of the Hyperraising construction in (40b). The stipulation that the CP in (40b) is defective lacks any independent evidence; it is merely required to make the construction compatible with the standard minimalist analysis of Raising that I discussed in chapter 1. Given that the CPs in (40a) and (40b) have the same properties, I assume instead that neither CP is defective and that the embedded T-heads of both CP-complements in (40) are in principle capable of valuing the case feature of an embedded subject DP. The real question that arises from data such as (40b), which is not answered by a stipulation such as Ferreira's, is why the subject DP in (40b) has to, and why it is allowed to, move to the matrix subject position, given that the embedded predicate is otherwise capable of assigning case, as (40a) illustrates. It is this question that I try to answer in chapters 5 and 6 of this thesis.

2.2.4 Hyperraising in Kipsigis

Jake and Odden (1979) observe that in Kipsigis, a Nilotic language spoken in East Africa, predicates such as, *nyôlu* ‚necessary,‘ and *wvy* ‚hard‘ trigger Hyperraising:

- (42) a. Wvy [kò-tíl kwò:nyik pè:ndó]
 hard 3SG -cut women meat
 ‚It is hard for the women to cut the meat.‘

- b. Wvyèn kwò:nyik [kò-tíl pè:ndó]
 hard (PL) women 3SG -cut meat
 ‚It is hard for the women to cut the meat.‘
- c. Wvy [kè:-más kiplàṅàt]
 hard 1PL-beat Kiplangat
 ‚It is hard for us to beat Kiplangat.‘
- d. Ki-wvyèn [kè:-más kiplàṅàt]
 1PL -hard (PL) 1PL -beat Kiplangat
 ‚It is hard for us to beat Kiplangat.‘

(Kipsigis; Jake and Odden, 1979: 146)

In all the examples in (42), the predicate *wvy* ‚hard‘ selects a finite CP whose verb is overtly marked for agreement. Jake and Odden (1979) observe that Kipsigis is a VSO language in which predicates bear subject/object-verb agreement morphology and subject DPs bear tones that differ from non-subject DPs. In addition, Kipsigis has a scrambling operation which allows subjects and objects to appear in any word order after the verb. In (42a), the first example of the non-Raising variant, the embedded subject *kwò:nyik* appears after the embedded finite verb *kò-tíl*, hence it is assumed that it is located in the embedded clause. In (42b), the DP *kwò:nyik* appears before the embedded verb but it still bears a subject tone and triggers agreement with the matrix verb *wvyèn*. This suggests that this DP is now in the matrix subject position. Furthermore, Jake and Odden (1979) observe that in Kipsigis, whenever a DP is topicalised clause-internally, the morpheme *ko* occurs between the preposed DP and the verb. In (42b), however, the DP *kwò:nyik* is not followed by the morpheme *ko*, which indicates that *kwò:nyik* has not simply been topicalised inside the embedded clause. All these observations suggest that the embedded subject DP *kwò:nyik* has moved out of the subject position of the complement clause to the matrix subject position.

In the second example of the unraised variant in (42c), the embedded verb is overtly marked for subject agreement (first person plural) while the matrix verb has no overt marking for agreement. In contrast, in the Raising variant in (42d), both the matrix and embedded verbs are overtly inflected for first person plural agreement. This not only suggests that the matrix and embedded subjects are coreferential but that the matrix subject originated in the embedded clause where it triggered agreement morphology on the embedded verb before raising into the matrix subject position to agree with the matrix predicate. This means that, in addition to languages with SVO word order, such as Bantu, and SOV languages such as Turkish, we also find Hyperraising from indicative clausal complements in languages with VSO word order.

2.2.5 Hyperraising in Bhojpuri

Similarly, Shukla (1981) shows that in Bhojpuri, predicates like *bujha:-* ‚appear’, *lag* ‚seem’, and *ma:lum ho:* ‚appear’, trigger Hyperraising of embedded subject DPs:

- (43) a. *i: la:g-a:la* [*ki Lalit Hindi: ja:na-a:la:*]
 it seem-3SG-MASC-PRES COMP Lalit Hindi know-3SG-MASC-PRES
 ‚It seems that Lalit knows Hindi.’
- b. Lalit *la:g-a:la* [*Hindi: ja:na-a:la*]
 Lalit seem-3SG-MASC-PRES Hindi know3SG-MASC-PRES
 ‚Lalit seems to know Hindi’

(Bhojpuri; Shukla, 1981: 252-253)

The embedded complements in (43) are finite CPs whose verbs are overtly marked for tense and agreement. In (43a), the thematic subject of the embedded clause is located in the embedded subject position, as is shown by the fact that the DP *Lalit* follows the complementiser *ki* in (43a). In contrast, in (43b), the DP *Lalit* appears in the matrix subject position. Furthermore, the matrix subject *Lalit* triggers agreement with both the matrix and embedded verbs. Shukla (1981) also observes that the matrix subject *Lalit* is understood as the subject of the embedded clause, and concludes that the matrix subject

has originated in the embedded clause and moved to the matrix subject position in (43b). Her evidence for this assumption comes from the interpretation of sentential idioms:

- (44) a. Lalit par bhu:t caDh-al ba:-y
 Lalit on ghost climb- (PERF) be-3SG-MASC-PRES
 ‚A ghost has climbed on Lalit.‘ (Literal interpretation)
 ‚Lalit is acting crazy.‘ (Idiomatic interpretation)
- b. Bhu:t lalit-par lag-a:la: caDh-al ba:-y
 ghost Lalit on seem-3SG-MASC-PRES climb- PERF be-3SG-MASC-PRES
 ‚A ghost seems to have climbed on Lalit.‘ (Literal interpretation)
 ‚Lalit seems to be acting crazy.‘ (Idiomatic interpretation)

(Bhojpuri; Shukla, 1981: 260-261)

Shukla's example (44b) shows that when the subject-part of an embedded idiom appears in a matrix clause with a predicate like *lag-* ‚seem,‘ the idiomatic reading is preserved. This supports her conclusion that the moved part was originally part of the embedded idiom and that, therefore, examples such as (43b) and (44b) involve Hyperraising from indicative clauses.

2.2.6 Hyper-Raising in Mandarin Chinese

Li (1990) and Ura (1994) have suggested that verbs like *kaneng* ‚likely/possible‘, *nan/rongyi* ‚difficult/easy‘ and *kaishi* ‚begin‘ trigger Hyperraising in the variety of Mandarin, spoken in Taiwan. Ura (1994) proposes a Hyperraising analysis for Mandarin Chinese, based on constructions like (45):

- (45) a. Keneng [ta hui qu nar]
 possible he will go there
 ‚It is possible that he will go there.‘

- b. Ta keneng [hui qu nar]
 he possible will go there
 * He is possible that he will go there. (Literal interpretation)
 ‚It is possible that he will go there.‘ (Intended meaning)

(Mandarin Chinese; Ura, 1994: 302; cf. Li, 1990)

The embedded CP in (45) is marked for future tense, which is an indication that the embedded clause is finite. In (45a), the thematic subject of the embedded clause is located in the embedded subject position. In contrast, in (45b), the position of the DP *ta* ‚he‘, is consistent with the idea that this DP is in the matrix subject position. Ura (1994) observes that the DP *ta* in (45b) must be understood as the subject of the embedded clause. He suggests that the matrix verb *keneng* ‚possible‘ in (45) does not assign a thematic role to its subject and that the word order of the sentence in (45b) is derived from (45a) via Hyperraising.

Li (1990) provides a number of arguments to show that Hyperraising is involved in the derivation of structures like (45b). The first piece of evidence has to do with the distribution of the Mandarin anaphors like *taziji* ‚himself‘. Such anaphors are subject to Binding Principle A, which requires that they must be clausemates of their antecedents. Consider the following example in (46):

- (46) Ta keneng-bu- keneng [zai taziji jia zuo shi]?
 he likely-not-likely at himself home do thing
 ‚Is he likely to do things at his own home?‘

(Mandarin Chinese; Li, 1990: 125)

In the example in (46), the anaphor *taziji* ‚himself‘ appears in the embedded clause, while its antecedent *ta* ‚he‘ is in the matrix clause. However, the sentence is grammatical, which according to Li (1990) suggests that the antecedent *ta* has originated in the

embedded subject position of the complement clause where it licensed the occurrence of the anaphor *taziji*, before moving to the matrix non-thematic subject position.

The second piece of evidence has to do with the idiom chunk *you-mo* ‚humor’. Li (1990:126) explains that in Chinese, *you-mo* is a V+O idiom chunk which historically, is a transliteration from the English word ‚humour’. As an idiom chunk, *you* and *mo* must appear together within the same clause. Li (1990) observes that in constructions involving Hyperraising predicates like *keneng*, when the idiom *you-mo* is split such that a part appears in the matrix clause, while the rest remains in the embedded clause, the idiomatic interpretation of the idiom is retained.

- (47) a. *Wo bu xihuan zheige mo
 I not like this -mour
- b. *Wo bu hui you
 I not can hu-
- c. Wo you le ta yi mo
 I hu- ASP him one -mour
 ‚I humoured him.’
- d. Zheige mo_i bei ta you-huai t_i le
 this -mour by him hu-bad ASP
 ‚This -mour was hu-ed bad by him.’ (Literal interpretation)
 ‚He ruined the joke.’ (Idiomatic interpretation)
- e. Zheige mo keneng [e bei ta you-huai] ma?
 this -mour likely by him hu-bad QP
 ‚Is this -mour likely to be hu-ed bad by him?’ (Literal interpretation)
 ‚Is it possible that he will ruin the joke?’ (Idiomatic interpretation)

(Mandarin Chinese; Li, 1990: 127)

Li (1990) observes that the examples in (47a) and (47b) are ungrammatical because only a part of the idiom chunk *you-mo* ‚humour’ appears in each of the sentences. Only example (47c), in which both parts of the idiom chunk occur within the same *clause*, is grammatical. However, in the passive construction in (47d), part of the idiom *mo* ‚-mour’ has undergone A-movement to the subject position, while the other part is still in the base position. In contrast to (47a) and (47b), the sentence remains grammatical and the idiomatic interpretation is preserved. Crucially, in example (47e), when part of the embedded idiom chunk *you-mo* appears in the matrix subject position of the Hyperraising verb *keneng*, the idiomatic reading is also maintained. Li (1990) therefore suggests that the part of the idiom that appears in the matrix clause must have originated in the embedded clause, and that the construction involves Hyperraising.

Li’s third argument for a Hyperraising analysis is that when the embedded verb of the Hyperraising predicative *keneng* is passivised, the meaning of the passive sentence is similar to that of the active sentence:

- (48) a. Zhege yisheng keneng jiancha Lisi ma?
 this doctor likely examine Lisi QP
 ‚Is this doctor likely to examine Lisi?’
- b. Lisi keneng bei zhege yisheng jiancha ma
 Lisi likely by this doctor examine QP
 ‚Is Lisi likely to be examined by the doctor?’

(Mandarin Chinese; Li, 1990: 127)

The reason for the similarity in meaning of the passive and the active constructions in (48) is that the DP *Lisi* is the internal argument of the embedded verb *jiancha* ‚examine’ in both examples, even though it is syntactically realised as the subject of the main clause in (48b). This familiar argument provides further support that Mandarin Chinese also allows subject-to-subject Raising from finite sentential complement clauses.

2.2.7 Hyper-Raising in Dholuo

It has been suggested by Ura (1994; see also Creider, 1989) that in Dholuo, a Western Nilotic language spoken in Kenya, predicates like *calo* ‚seem’ trigger Raising of the embedded subject DP to the matrix subject position:

- (49) a. \emptyset -calo [ni un u-sin]
 3SG-seem COMP you-PL 2 PL-unhappy
 ‚It seems that you are unhappy.’
- b. Un u-calo [ni u-sin]
 you (PL) 2PL -seem COMP 2PL -unhappy
 *‚You seem that you are unhappy.’ (Literal interpretation)
 ‚You seem to be unhappy.’ (Intended meaning)

(Dholuo; Creider, 1989: 136-137; Ura, 1994: 300)

In both the expletive construction in (49a) and the Raising construction in (49b), the matrix verb *calo* selects a finite complement introduced by an overt complementiser *ni*. In (49a), the thematic subject of the embedded clause is in the embedded subject position shown by the fact that the DP *un* ‚you’ appears after the complementiser in (49a). In contrast, in (49b), the DP *un* appears in the matrix subject position and agrees with the matrix verb *calo* which shows noun class agreement with the subject DP. The fact that the raised DP in (49b) agrees with the embedded predicate also suggests that it has raised to the matrix subject position.

2.2.8 Hyper-Raising in Finnish

A Hyperraising analysis has also been proposed by Ura (1994; see also Sulkala & Karjalainen, 1992) for Finnish predicates like *oli* ‚be’:

- (50) a. oli mukava [että he tulivat]
 be-IMPERF-3SG nice COMP they come--IMPERF-3 PL
 ‚It was nice that they came.’

- b. He olivat mukava [että tulivat]
 they be-IMPERF -3PL nice COMP come-IMPERF-3 PL
 *,‘They were nice that they came.’ (Literal interpretation)
 ‘It was nice that they came.’ (Intended meaning)

(Finnish; Sulkala & Karjalainen, 1992: 192)

In both the expletive construction in (50a) and the Raising construction in (50b), the matrix predicate *oli* ‘be’ selects a finite complement introduced by an overt complementiser *että*. In (50a), the thematic subject of the embedded clause is in the embedded subject position shown by the presence of the DP *he* ‘they’ after the complementiser in (50a). In contrast, in (50b), the DP *he* appears in the matrix subject position and agrees with the matrix verb *oli* which shows noun class agreement with the subject DP, and the fact that the raised DP in (50b) agrees with the embedded predicate further suggests that it has raised to the matrix subject position.

2.2.9 Hyper-Raising in Moroccan Arabic

Ura (1994, cf. Harrel, 1962; Wager, 1983) also suggests that the predicate *ttshab-li* ‘seem’ triggers Hyperraising in Moroccan Arabic, a VSO-language:

- (51) a. ttshab-li [beli žat mmi]
 seemed-3SG.MASC-to-1SG COMP came-3SG.FEM mother1SG
 ‘It seemed to me that my mother came.’
- b. Ttshab-et-li mmi [beli žat t_i]
 seemed-3SG.FEM-to-1SG mother1SG COMP came-3SG.FEM
 * ‘My mother seemed to me that she came.’ (Literal interpretation)
 ‘It seemed to me that my mother came.’ (Intended meaning)

(Moroccan Arabic; Ura, 1994: 299)

In both the expletive construction in (51a) and the Raising construction in (51b), the matrix predicate *ttshab-li* selects a finite complement introduced by an overt complementiser *beli*. While the raised DP *mmi* ‚mother’ in (51b) agrees with the embedded predicate, its position preceding the complementiser clearly suggests that it has raised to the matrix subject position. Hence, (51) is a clear case of Hyperraising.

2.2.10 Hyperraising in other languages

In this final sub-section, I present data from Maithili (Yadava, 1989) and Telugu (Krishnamurti & Gwynn, 1985; Ura, 1994) which are also consistent with an analysis in terms of Hyperraising. However, the relevant sources from which I have adopted the examples below only provide very little corroborating evidence for the hypothesis that we are dealing with Hyperraising. Therefore, I consider the examples below as only tentative further support for my claim that Hyperraising is a widespread phenomenon in the languages of the world:

- (52) a. [dongalu paDu-tunna Tlu] un-di
 thieves come-DUR COMP seem-3SG-NEU-PRES
 ‚It seems that thieves are coming.’
- b. Dongalu [paDu-tunn Tlu] un-naaru
 thieves come-DUR COMP seem-3PL-MASC-PRES
 *,‚Thieves seem that they are coming.’ (Literal interpretation)
 ‚It seems that thieves are coming.’ (Intended meaning)

(Telugu; Ura, 1994: 299)

- (53) a. lagaet aich [je barsa ai nai haet]
 seems that rain today not will be
 ‚It seems that it will not rain today.’

- b. barsa lagaet aich [je ai nai haet]
rain seems that today not will be
„*Rain seems like it will not fall today.’ (Literal interpretation)
„It seems that it will not rain today. (Intended meaning)

(Maithili; Yadava, 1989: 2)

All the matrix predicates in examples (52) and (53) select finite complements with overt complementisers and embedded verbs which have overt agreement and/or tense morphology. In the (a) examples, the thematic subject of the embedded clause is located in the embedded subject position. In contrast, in the (b) examples, the thematic subject of the embedded clause appears in the matrix subject position and therefore triggers agreement with the matrix predicate. The translation of the matrix predicates in these examples suggests that we are dealing with Raising predicates. Furthermore, these matrix predicates do not select thematic subjects in the (a) examples, which suggests that they are unaccusative. As was argued in various places above, this in turn suggests that the matrix subjects in the (b) examples did not originate in the matrix subject positions, but have moved there via Hyperraising. This means that, despite the absence of additional evidence, it is probably justified to follow Ura (1994) and Yadava (1989) in assuming that the examples in (52) and (53) constitute genuine examples of Hyperraising.

In conclusion, the data discussed in sections 2.1 and 2.2 provide overwhelming evidence that many languages allow for embedded subject DPs to undergo long A-movement from their original position across a finite CP-node into the matrix subject position. In all the examples discussed above, this type of movement left behind a gap in the embedded subject position. Although it is tempting to analyse this gap as the unpronounced copy/trace of the moved subject DP, as indeed many authors have done, I argue in the chapters below that the gap is actually an unpronounced resumptive pronoun. This assumption allows me to group the Hyperraising constructions in the languages discussed above together with Hyperraising constructions in which the embedded subject position is

overtly realised by a pronoun which is obligatorily coreferential with the moved subject DP. These so-called Copy Raising constructions are discussed in the next section.

2.3 Copy Raising: Hyperraising with resumptive pronouns

In addition to examples of Raising out of finite subjunctive and indicative complements which leave a gap in the embedded clause, there are also instances where the moved subject leaves an overt pronominal copy at the point of extraction in a finite complement.

2.3.1 Copy Raising in Haitian Creole

According to Deprez (1992), in Haitian Creole, predicates like *sanble* can trigger the Raising of a subject DP in constructions that involve tensed complements. The original position of the raised subject must be realised by a pronominal “copy”, i.e. a pronoun that is obligatorily interpreted as coreferential with the raised subject DP:

- (54) a. *Sanble* [Jan pati]
 seems John left
 ‘It seems that John left.’
- b. Jan *sanble* [li pati]
 John seems he leaves
 ‘John seems he to have left.’
- c. *Jan *sanble* [pati]
 John seems leave
 ‘John seems to have left.’

(Haitian Creole; Deprez, 1992: 192)

The matrix predicate *sanble* in (54) selects a finite CP. This is illustrated by the fact that the embedded verb has past tense morphology. In (54a), the thematic subject of the embedded clause *Jan* is located in the embedded subject position. In contrast, in (54b),

the DP *Jan* appears in the matrix clause. In (54c), the pronominal DP *li* which is the subject of the embedded finite clause is absent. This renders the sentence in (54c) ungrammatical. The ungrammaticality of (54c) suggests therefore that a pronominal copy is obligatorily required at the point of extraction in the embedded clause in (54)

Deprez (1992) presents a number of arguments to show that Copy Raising takes place in constructions involving the predicate *sanble*. Deprez (1992) notes that the matrix subject and the embedded predicate form a single semantic unit: as was observed with respect to the Hyperraising constructions discussed in section 2.1 and 2.2, sentential idioms in Haitian Creole Copy Raising constructions can preserve their idiomatic interpretation when part of the idiomatic expression is raised, as shown in (55):

- (55) a. Lakay fe nwa
 the house makes black
 „We have money problems.’
- b. Lakay sanble [li fe nwa]
 the house seems makes black
 „It seems we have money troubles.’

(Haitian Creole; Deprez, 1992: 206)

According to Deprez (1992), the Copy Raising verb *sanble* also takes an expletive pronoun *li* as its subject, which suggests that it is unaccusative, (56):

- (56) li sanble [l’ap fe lanej]
 it seems it is making snow
 „It is snowing.’

(Haitian Creole; Deprez, 1992:207)

The fact that the Haitian Creole predicate *sanble* can accommodate a semantically empty element as its subject indicates that *sanble* does not assign an external theta role. This

means that the subject DP *Jan* in (54) and the subject DP *lakay* in (55b) are not arguments of the matrix verb and have rather moved into the matrix subject position:

2.3.2 Copy Raising in Igbo

Ura (1998) presents an analysis of Hyperraising in Igbo which involves DP movement out of a finite indicative complement clause. In the examples in (57), the matrix predicate *di* ‚seem’ selects a finite complement clause introduced by the complementiser *kà*. In (57a), the thematic subject of the complement clause, the subject DP *Ézè*, is located in the embedded subject position as evidenced by the fact that the DP *Ézè* follows the complementiser. In contrast, in (57b), the DP *Ézè* appears in the matrix subject position while the embedded subject position is occupied by an obligatorily coreferential pronominal copy *o* ‚he’:

- (57) a. *Ó* *di* *m* [*kà* *Ézè* *hũ-rũ* *Adá*]
 EXPL seems to me COMP Eze see-ASP Ada
 ‚It seems to me that Eze saw Ada.’
- b. *Ézè_i* *di* *m* [*kà* *o_i* *hũ-rũ* *Adá*]
 Eze seems to me COMP he see-ASP Ada
 ‚Eze seems to me that he saw Ada.’ (Literal interpretation)
 ‚It seems to me that Eze saw Ada.’ (Intended meaning)

(Igbo; Ura, 1998: 68)

Ura (1998) points out that Igbo examples such as (57) test positive to some of the traditional diagnostics for Raising. For example, the Igbo Hyperraising predicate *di* in (57a) has the expletive *ó* in its subject position. This indicates that *di* does not select an external argument. Therefore, the matrix subject DP in (57b) must have moved from the embedded subject position to the matrix subject position.

Ura (1998) also employs the classical idiom-test to show that constructions such as those in (57) involve Hyperraising. (58b) shows that an idiomatic expression in an embedded

clause in Igbo preserves its meaning even when part of the idiom appears in the matrix clause:

- (58) a. *Ihe é-kpù-ru na ñgwò a-ghá-shía la*
 thing PEF-cover LOC palm PEF -come-off PERF
 „The cover on the palm tree has come off.’ (Literal interpretation)
 „The secret has been revealed.’ (Idiomatic interpretation)
- b. *Íhe é-kpù-ru na ñgwò dí [kà ọ ghá-shía la]*
 thing PEF -cover LOC palm seems COMP it come-off PERF
 „The cover on the palm tree seems that it has come off.’ (Literal interpretation)
 „The secret seems to have been revealed.’ (Idiomatic interpretation)

(Igbo; Ura, 1998: 69)

Finally, Ura (1998) shows that the fact that the matrix subject DP *Ézè* in (59) can bind an anaphor in the matrix clause is an indication that the DP *Ézè* is now located in an A-position in the matrix clause:

- (59) *Ézé_i di onwé yá [kà ọ_i hũ-rũ Adá]*
 Eze seems to himself COMP he see-ASP Ada
 „Eze seems to himself that he saw Ada.’

(Igbo; Ura, 1998: 68-69)

The grammaticality of (59) shows that the examples in (57)-(59) are not instances of long topicalisation (A-bar movement), but do indeed involve DP-movement to an A-position in the matrix clause. This means that these constructions are derived via Hyperraising, i.e. A-movement of a DP across a finite CP-node which leaves a pronominal copy at the point of extraction.

2.3.3 Copy Raising in Yoruba

Adesola (2005) shows that in Yoruba, Raising of an embedded subject DP leaves an overt pronominal copy at the point of extraction in the finite complement clause:

- (60) a. *Ó* *jọ* [*pé Olú àti Adé ní owó lọwọ*]
 EXPL resemble that Olu and Ade have money in hand
 ‘It seems that Olu and Ade are rich.’
- b. *Olú àti Adé jọ* [*pé wón_i ní owó lọwọ*]
 Olu and Ade resemble that they have money in hand
 ‘Olu and Ade seem to be rich.’

(Yoruba; Adesola, 2005: 110-112)

In both examples in (60), the matrix predicate *jọ* ‘seem’ selects a finite complement clause introduced by the complementiser *pé* ‘that’. In (60a), the thematic subject of the complement clause is located in the embedded subject position. This is shown by the fact that the DP *Olú àti Adé* follows the complementiser in (60a). In contrast, in (60b), the DP *Olú àti Adé* appears in the matrix subject position while the embedded subject position is occupied by an obligatorily coreferential pronominal copy *wón* ‘they’.

Adesola (2005) provides one of the classical arguments in favour of a Raising analysis. Sentence (60a) is an expletive construction with the expletive pronoun *ó* merged in the [Spec, T] position of the matrix clause. That the expletive *ó* can occupy the subject position of the predicate *jọ* suggests that *jọ* does not assign an external thematic role and that the matrix subject in (60b) has moved there. Also, Yoruba Hyperraising constructions involving *jọ* can preserve the idiomatic interpretation of an embedded sentential idiom when part of the idiomatic expression appears in the matrix clause:

- (61) a. ó jo [pé omí pò ju okà lo]
 it seems that water is more yam flour SUPERL
 „It seems that the water is more than the yam flour.’ (Literal interpretation)
 „It seems that a person is living beyond his means.’ (Idiomatic
 interpretation)
- b. Omí jo [pé ó pò ju okà lo]
 water seems that it is more yam flour SUPERL
 „The water seems to be more than the yam flour.’ (Literal interpretation)
 „A person seems to be living beyond his means.’ (Idiomatic interpretation)

Yoruba, like Igbo and Haitian Creole, hence exhibits Copy Raising out of finite clauses.

2.3.4 Copy Raising in Hebrew

Finally, Lappin (1984) cites an example that suggests that there is Copy Raising out of finite indicative clauses in Hebrew:

- (62) a. Ze nireh ke-ilu she Haim sameah
 It appears as if that Haim is happy
 „It appears as if Haim is happy.’
- b. Haim nireh ke-ilu she hu sameah
 Haim appears as if that he is happy
 „Haim appears as if he is happy.’

(Hebrew; Lappin, 1984: 247)

The Hebrew Raising predicate *nireh* ‚appear’ in (62) selects a finite embedded CP with an overt complementiser *she* ‚that’. In (62a), the thematic subject of the complement clause is located in the embedded subject position. This is shown by the fact that the DP *Haim* follows the complementiser in (62a). In contrast, in (62b), the DP *Haim* appears in the matrix subject position while the embedded subject position is occupied by an

obligatorily coreferential pronominal copy *hu* ‚he‘. The fact that *ze* ‚it‘ can appear in the subject position of the matrix predicate *nireh* indicates that *nireh* does not assign an external theta role and that the matrix subject in (62b) may have moved from the embedded subject position to its present position in the matrix clause.

However, Lappin (1984) does not provide any corroborating evidence that the examples in (62) are really derived by long subject-to-subject movement. Although the example in (62) is certainly consistent with such an analysis, there are other possible treatments of this and comparable constructions. In order to make this point clearer, I will now address constructions from English and Swedish which look remarkably similar to the Copy Raising constructions discussed in the previous sections. For these constructions, however, it has been shown that they are *not* derived by long A-movement. It is the evidence for this latter point that I review in the last section of this chapter.

2.4 Arguments against a Copy Raising Analysis for English-type Languages

In this section, I discuss English and Swedish examples like (63) and (64), which at first sight seem to be similar to Copy Raising examples in Haitian Creole, Igbo and Yoruba:

- (63) a. It seems like/ as if/ as though Tina adores ice cream.
b. Tina seems like/ as if/ as though she adores ice cream.

- (64) a. Det verkar som om Tina gillar glass.
It seems as if Tina likes ice cream
‚It seems like Tina likes ice cream.‘

b. Tina verkar som om hon gillar glass.
Tina seems as if she likes ice cream
‚Tina seems like she likes ice cream.‘

(Swedish; Asudeh and Toivonen, 2007: 3)

Despite the similarity between the English/Swedish examples in (63) and (64) on the one hand, and the Haitian Creole (54), Igbo (57) and Yoruba (60) examples on the other hand, it has been argued by various authors (such as Lappin (1984), Deprez (1992), Potsdam and Runner, (2001) and Zeller (2006b)) that examples such as (63) and (64) are in fact different from the Copy Raising-examples discussed in section 2.3.

Zeller (2006b) argues that examples like (63) do not constitute a genuine instance of Copy Raising because the complement of the construction in (63) is introduced by particles such as *like*, *as if*, *as though*, while complements of Hyperraising or Copy Raising predicates are usually introduced by genuine complementisers like *that* (compare e.g. *jo* (Yoruba) or *di* (Igbo)). Matushansky (2002: 221) submits that while the *seem like/as if/as though* constructions “require direct visual perception”, standard Raising predicates “are interpreted as epistemic judgements”: whereas a sentence such as *John seems to be cooking* is appropriate in a situation in which the speaker only smells food coming from John’s kitchen, a sentence such as *John seems as if he’s cooking* would not really be appropriate in this context and would only be possible if the speaker can actually see John doing something in the kitchen. Importantly, the examples of Hyperraising and Copy Raising discussed above can all have an interpretation as epistemic statements, which shows that they are fundamentally different from the English constructions in (63) and (64).

Furthermore, Lappin (1984) and Potsdam and Runner, (2001) observe that while regular Raising constructions like (65) permit both wide and narrow scope readings of the raised subject, constructions such as (66) lack scope ambiguity and only have the wide scope reading.

- (65) Two people seem to have won the lottery =
„It seems that two people have won the lottery.’ (Narrow scope: *seem* has scope over *two people*) OR
„Two people are such that they seem to have won the lottery.’ (Wide scope: *two people* has scope over *seem*).

- (66) Two people seem like they have won the lottery =
„Two people are such that they seem like they have won the lottery.’ (Wide scope)
NOT: „It seems like two people have won the lottery.’ (*Narrow scope)

(Potsdam and Runner, 2001: 463)

Moreover, when part of an idiom chunk is raised in the „*seem as if*’ constructions it results in ungrammaticality as in (67c) and (67d):

- (67) a. Advantage seems to have been taken of John.
b. Much headway appears to have been made on the project.
c. *Advantage seems as if it had been taken of John.
d. *Much headway appears as if it had been made on the project.

(Lappin, 1984: 241)

Regular Raising constructions maintain their idiomatic interpretation when the subject-part of the idiom is raised (note that the idioms in (67a) and (67b) are VP-idioms whose direct objects have been passivised and have been promoted to subject status). This is why (67a) and (67b) are grammatical. In contrast, (67c) and (67d) show that the matrix subject of a „*seem as if*’ construction cannot be reconstructed as part of an embedded idiom.

Deprez (1992) shows that unlike regular Raising constructions, in the „*seem as if*’ constructions, the link between the matrix subject DP and the embedded pronominal DP is not restricted to the subject position:

- (68) a. John seems as if everyone likes him.
b. John seems as if his mother died.

- c. John seems as if his mother hit him.
- d. John seems as if his temper is getting the best of him again.

(Deprez, 1992: 225)

Similarly, Landau (2009) suggests that in the '*seem as if*' construction, a relation may not only exist between the matrix subject DP and a pronoun in a non-subject position in the complement (as in (68)), but can also extend to embedded events:

- (69)
- a. John looked like something terrible had happened.
 - b. John looked like he just learned that something terrible had happened.
 - c. John looked like something terrible had happened to him.

(Landau, 2009: 344)

Landau (2009) observes that in the context where an individual watching the TV in another room suddenly rushes in, looking livid and shocked, the sentence in (69a) could be expressed and interpreted as either (69b) or (69c). In contrast, in Haitian Creole, Igbo and Yoruba Hyperraising constructions, the relation is strictly between the matrix subject DP and the pronominal DP in the embedded subject position.

2.5 Conclusion

In the foregoing discussion, empirical evidence from several languages has been presented to counter the assumption that Raising can only occur out of non-finite defective embedded clauses. From the preceding sections, it is clear that an embedded subject DP can be moved to the matrix subject position, not only from finite subjunctive complements in languages like Greek, Japanese and Rumanian, but also from finite indicative clauses in languages like Turkish, Brazilian Portuguese and in many Bantu languages. In some cases, a subject DP that is moved out of a finite indicative complement leaves a pronominal copy at the point of extraction in languages like

Yoruba, Igbo, Haitian Creole and Hebrew. The Minimalist assumption is that an embedded subject DP moves out of the embedded clause only if the complement is not a CP but a defective non-finite TP whose T-head is unable to assign nominative case to its subject. Therefore, the main problems that all theoretical analyses of the data presented above have had to solve are: (1) If the embedded clause is a finite CP, why does the subject have to raise and get nominative case from the matrix T-head? (2) How can case be assigned by the matrix T-head, and how can the embedded subject raise to matrix [Spec, T], given that there is an intervening CP? In chapter 4, I discuss some of the solutions that have been proposed in the literature on Hyper- and Copy Raising, and I point out shortcomings and problems for the existing proposals. However, before I turn to these proposals, I present the second major set of empirical data that illustrate that long A-movement is attested in many of the world's languages in the following chapter 3.

CHAPTER 3

Long subject-to-object raising

In the Minimalist Program, the analysis of ECM constructions operates on the assumption that ECM predicates select defective TPs that lack a CP layer. The embedded T-head therefore cannot assign case to its subject. Due also to the absence of a CP in a defective clause, the embedded subject DP is able to engage in a long distance agreement relation with the matrix light verb *v*. Subsequently, the functional head *v* of the matrix clause assigns accusative case to the subject of the embedded TP. It is not expected that a subject DP embedded within a CP would be assigned accusative case by a matrix light verb. However, as I demonstrate in this chapter, empirical data from languages like Greek, Turkish, Korean, Japanese, etc. provide evidence that the subject of an embedded finite clause can be assigned case by *v* in the matrix clause despite the presence of an intervening CP. Furthermore, this type of case assignment can be followed by movement of the embedded subject to the matrix object position. Henceforth, I refer to DP-movement from the embedded subject position of a finite complement to the matrix object position as *Hyper-ECM*. In section 3.1, I present data from and provide a detailed discussion of languages that manifest Hyper-ECM. In 3.2, I briefly discuss the fact that I have not been able to locate data which could be interpreted as genuine cases of “Copy ECM”, i.e. constructions with subject-to-object Raising where the base position of the raised subject in the embedded clause would be marked with an obligatory overtly realised resumptive pronoun.

3.1 Hyper-ECM

3.1.1 Hyper-ECM in Balkan languages (Greek and Rumanian)

Joseph (1976) shows that in Greek, an embedded subject DP in a finite complement clause of the verb *θεωρο*, ‘consider’, can be assigned nominative case by the embedded finite T-head as in (1):

- (1) Θ eoro [pos o yanis ine eksipnos]
 consider-1SG COMP NOM-John be-SG smart
 ‚I consider John to be smart.‘

(Greek; Joseph 1976: 241)

In (1) the matrix predicate *theoro* selects a finite indicative complement with an overt complementiser, *pos*. The embedded finite T-head is overtly marked for agreement and, as expected, the case feature of the embedded subject DP *o yanis* is valued as nominative by the embedded finite T-head.

Interestingly, the subject of the embedded finite CP can also be assigned accusative case by the matrix light verb:

- (2) Θ eoro ton yani [pos ine eksipnos]
 consider-1SG ACC-John COMP be-SG smart
 ‚I consider John to be smart.‘

(Greek; Joseph 1976: 241)

Both sentences in (1) and (2) have a finite indicative complement with an overt complementiser and a T-head that is inflected for agreement. The two sentences are semantically the same. The important difference is that (1) has a nominative embedded subject that occurs after the overt complementiser *pos* while in (2), the subject of the embedded clause bears accusative case and appears before the complementiser *pos*. Joseph (1976) therefore assumes that the accusative subject of the lower clause in (2) has raised from the embedded subject position to the matrix object position, leaving a gap in the embedded subject position. This means that (2) is an example of Hyper-ECM.

In order to support this assumption, Joseph (1976) provides arguments based on the differences between object control verbs like *episa* ‚persuade‘, which select matrix object arguments, and verbs like *θeoro*, ‚consider‘, which select sentential complements. First, when the embedded complement of the predicate *θeoro* is passivised, the meaning of the active construction is synonymous with the passive construction, in contrast to what obtains when the complement of *episa* is passivised.

- (3) a. *Θeoro ton petro [pos eklepse afto ton skilo]*
 consider-1 SG ACC-Peter COMP stole-3SG this-the-dog- ACC
 ‚I consider Peter to have stolen this dog.‘
- b. *Θeoro afto ton skilo [pos ine klemenos apo ton petro]*
 consider-1SG this-the-dog- ACC COMP be-3SG stolen-NOM by Peter
 ‚I consider this dog to have been stolen by Peter.‘

(Greek; Joseph 1976: 244)

(3a) and (3b) are synonymous. This is in contrast to (4a) and (4b) below:

- (4) a. *Episa ton yatro [na eksetasi ton yani]*
 persuaded-1SG ACC-doctor SUBJ examine-3SG ACC-John
 ‚I persuaded the doctor to examine John.‘
- b. *Episa ton yani [na eksetasθi apo ton yatro]*
 persuaded-1 SG ACC -John SUBJ examine-PASS-3 SG by doctor
 ‚I persuaded John to be examined by the doctor.‘

(Greek; Joseph 1976: 244)

The passive and active constructions in (3) are similar because the DP *skilo* ‚dog‘ is the internal argument of the verb *eklepse* ‚stole‘ in both examples even though *skilo* is syntactically realized as the object of the main clause in (3b). In contrast, (4a) and (4b)

are not synonymous. In (4a), it is the doctor that is persuaded to examine John while in (4b), it is John who is persuaded of the need to be examined. This is similar to the difference that was observed between subject-to-subject Raising and subject Control constructions.

Second, Joseph (1976) observes that a sentential idiom such as *ksilo pefi (se kapyo)*, which literally means “wood falls (on someone)” preserves its idiomatic reading when its subject part is realised as the accusative object of the predicate *θeoro*. In contrast, the idiomatic reading is unavailable if the idiom is embedded under *episa*, with the subject realised as the matrix object:

- (5) a. Θ eoro ksilo na exi pesi se afton
 consider-1 SG wood SUBJ have-AUX fallen on him- ACC
 ‚I consider wood to have fallen on him’ (literal)
 ‚I consider him to have suffered in the fight.’ (idiomatic)
- b. *Episa ksilo na pesi se afton
 persuaded-1 SG wood SUBJ fall-3 SG on him- ACC
 ‚I persuaded him to get hurt (in the fight).’

(Greek; Joseph 1976: 246)

The fact that the embedded idiom in (5a) retains its idiomatic reading with a part of it in the matrix object position is an indication that the raised part originated in the embedded clause. In contrast, (5b) lacks an idiomatic reading, because the matrix predicate subcategorizes for a matrix object. The DP *ksilo* in (5b) is therefore an argument of the matrix predicate and at no stage part of the embedded idiom.

A similar idea is echoed by Rivero (1991), who suggests that in Balkan languages like Rumanian and Greek, which lack infinitives, it is possible for the subject DP of an

embedded finite subjunctive clause to be assigned accusative case by the matrix light verb:

- (6) a. Am vrut [ca cineva să citească cartea]
I-have wanted that somebody SUBJ read book.the
- b. Am vrut pe cineva [să citească cartea]
I-have wanted to somebody SUBJ read book.the
'I have wanted somebody to read the book'

(Rumanian; Rivero, 1991: 276)

In (6a), the embedded subject *cineva* gets nominative case from the embedded finite subjunctive T-head. In contrast, in (6b), the embedded subject has received accusative case from the matrix light verb. Notably, Rivero (1991) analyses the particle *pe* in (6b) as an accusative case marker.

Rivero (1991) does not provide corroborating evidence that would prove that (6b) involves Hyper-ECM. However, the parallel between the Greek examples discussed by Joseph, and her example in (6), suggests that Rumanian, like Greek, allows for subjects of finite embedded sentences to become the objects of matrix predicates such as *vrut* 'want'. (6b) is interesting for another reason as well. Whereas the non-raised subject in (6a) is realised as part of a complement clause which is introduced by an overt complementiser, this complementiser is absent in Rivero's example in (6b). Crucially, Rivero notes that it would not be possible for the embedded subject *cineva* to be assigned accusative case by the matrix light verb if the overt complementiser *ca* appeared in (6b).¹⁵

¹⁵ Not surprisingly, just as is the case with infinitival ECM-constructions, there are different views regarding the syntactic position of the embedded accusative subject. For example, while Tanaka (2002) and Hong (2004) propose that the accusative embedded subject in Japanese and Korean are base generated in the embedded clause and raise to the matrix object position, Rivero (1991) suggests in Rumanian and Greek, the accusative embedded subject remains in the embedded clause and gets accusative case from the matrix light verb because the embedded CP is transparent.

This point mirrors a similar observation that was made by Grosu & Horvath (1984) regarding Hyperraising in Rumanian (see chapter 2, section 2.1.4). It shows that in some languages, A-movement out of finite embedded clauses is not possible if the finite clause is introduced by a complementiser. I return to this important point in my analysis of long A-movement in chapter 6

3.1.2 Hyper-ECM in Korean

According to Hong (2005), Korean is another language with Hyper-ECM. First, consider the example in (7):

- (7) John-i [Mary-ka cengcikha-ess-tako] sayngkakha-n-ta
 John-NOM mary-NOM honest-PAST-COMP think-PRES
 ‚John believes that Mary was honest‘

(Korean; Hong, 2005: 59)

In (7) the matrix predicate *sayngkakha-n-ta* selects a finite indicative complement with an overt complementiser *tako*. The embedded finite T-head is overtly marked for tense (past) and, as expected, the case feature of the embedded subject DP *Mary-ka* is valued as nominative by the embedded finite T-head. But now consider (8), which shows that, as in Greek and Rumanian, a thematic subject of the embedded finite CP can also be assigned accusative case by the matrix light verb in Korean:

- (8) John-i Mary-lul [cengcikha-ess-tako] sayngkakha-n-ta
 John-NOM Mary-ACC honest-PAST-COMP think-PRES
 ‚John believes that Mary was honest‘

(Korean; Hong, 2005:59)

In (8), the finite embedded clause also has an overt complementiser *tako* and the embedded verb is overtly marked for tense (usually an indication that the T-head can

assign nominative case). Yet, the embedded subject is assigned accusative case by the matrix light verb. (7) and (8) show that Korean has some verbs that select complements in which the subject of the embedded finite indicative clause can be marked with either nominative or accusative case without any adverse effect on grammaticality. This is in contrast to what takes place in languages like English in which nominative case is available to the subject of the finite complement of the ECM predicates *believe* (see example (2a) of chapter 1), while the embedded subject gets accusative case from the matrix light verb only when the complement is a defective (and therefore non-finite) clause (see example (2b) of chapter 1).

Hong (2005) presents a number of arguments to show that the matrix object in constructions such as (9) originates in the subject position of the embedded finite indicative CP. His first argument is based on the system of honorific marking that exists in Korean. According to Hong (2005), honorific marking is an instance of agreement in Korean that is established locally via a spec-head relation between the honorific DP and the verb:

- (9) a. Mary-ka [halmeni-kkeyse apu-si-tako] sayngkakha-ess-ta
 Mary-NOM grandmother-HON.NOM sick-HON-COMP think-PAST
- b. Mary-ka halmeni-lul [apu-si- tako] sayngkakha-ess-ta
 Mary-NOM grandmother-ACC sick-HON-COMP think-PAST
 ‚Mary thought that her grandmother was sick.’

(Korean; Hong, 2005:60)

In (9a), the embedded subject marked with honorific nominative case *-kkeyse* sanctions the honorific morpheme *-si* on the embedded verb through spec-head honorific agreement. In (9b), the embedded verb *apu-* is also inflected with the honorific suffix *si-*, and the only DP that could act as a licenser for this agreement is again the DP *halmeni* ‚grandmother’. However, this DP is overtly realised in the matrix clause and is marked with accusative case. Hong (2005) concludes that honorific agreement on the embedded

verb *apu-si-* is explained by the assumption that the DP *halmeni* was in the embedded subject position in a spec-head relation with the embedded verb where it licensed the honorific suffix *si-* on the embedded verb before moving into the matrix clause to be assigned accusative case by the matrix light verb.

The second argument presented by Hong (2005) in support of the assumption that the matrix object in Korean Hyper-ECM originates in the embedded subject position has to do with quantifier stranding:

- (10) John-i haksayng-ul [sey myeng-i cengcikha-ess-tako] sayngkakha-n-ta
John-NOM student-ACC three CL-NOM honest- PAST - COMP think
,,John thinks three students were honest.’

(Korean; Hong, 2005: 85)

The noun *haksayng* ‚student’ and its quantifier *sey myeng* form a complex nominal constituent. However in (10), the quantifier and the DP appear in different positions. Hong (2005) suggests that *haksayng* originates in the embedded subject position but raises into the matrix clause while leaving behind its quantifier *sey myeng*. Consequently, *haksayng* is assigned accusative case *-ul* in the matrix clause by the matrix light verb. In contrast, the stranded quantifier is assigned nominative case *-i* in the embedded clause by the finite T-head. This example is an important illustration that the embedded finite clause in (10) is not defective – nominative case is indeed available, but crucially, it is not assigned to the raised DP, but to an embedded quantificational head. In chapter 5, I will argue that this pattern, overtly realised in (10), in fact underlies all examples of long A-movement discussed in this thesis.

The availability of two structural cases in long A-movement constructions is also illustrated by Hong’s (2005) third argument, which relates to case mismatch between a possessor DP and the possessed DP. Hong (2005) observes that in Korean, both the possessor and possessed DP must have the same case marking:

- (11) a. John-i elkwul-i/*ul tachi-ess-ta
 John-NOM face-NOM /* ACC hurt-PAST
 ‚John’s face got hurt.‘
- b. Bill-i John-ul elkwul-ul/*i ttayli-ess-ta
 Bill-NOM John-ACC face-ACC /* NOM hit-PAST
 ‚Bill hit John’s face.‘

(Korean; Hong, 2005: 89)

The examples in (11) show that the possessor DP *John* must bear the same case marking as the possessee – nominative in (11a), and accusative in (11b). However, in (12) below, there is a case mismatch between the possessor *emeni-lul* ‚mother-Acc‘ and the possessed DP *elkwul-i* ‚face-Nom‘. Yet the sentence is grammatical:

- (12) Sue-ka emeni-lul [elkwul-i kowu-si-tako] sayngkakha-n-ta
 Sue-NOM mother-ACC face-NOM pretty-HON-COMP think-PRES
 ‚Sue thinks her mother’s face is pretty.‘

(Korean; Hong, 2005: 89)

Note that the embedded predicate *kowu* ‚pretty‘ in the finite indicative complement clause bears honorific marking *-si*, which signals agreement between the predicate and its subject (Hong, 2005). Hong (2005) therefore suggests that in (12), the possessor DP *emeni* ‚mother‘, with the possessee *elkwul* ‚face‘, originated in the embedded subject position of the complement clause where the DP *emeni* licensed the honorific morphology on the embedded predicate in a spec-head configuration before moving into the matrix object position and leaving the possessed DP behind in the embedded subject position. While the raised possessor DP is assigned accusative case by the matrix light verb, the stranded possessed DP is assigned nominative case by the embedded finite T-head.

Again, (12) illustrates that in Hyper-ECM constructions, two cases are in fact available: accusative case from the matrix light verb *v*, and nominative case from the embedded

finite T. In addition, (12) has another important characteristic that will become important for my analysis of this and other long A-movement constructions: Given the standard assumption that possessors merge as the specifiers of their possesses (or possessum), the raised DP in (12) does not really undergo subject-to-object movement, but rather *specifier-of-subject-to-object* movement, thereby stranding the possessor inside the complex nominative DP.¹⁶ As will become clear later, I suggest that long A-movement always involves extraction of a DP from another DP (and that the extracted DP receives case from the matrix clause) plus it involves stranding of the complex DP from which extraction took place (and that the stranded DP will be marked with nominative case).

The fourth argument provided by Hong (2005) is that it is possible to passivise the embedded subject of the Hyper-ECM construction in Korean (see section 1.6 of chapter 1):

- (13) a. John-i Sue-lul [ttoktokha-ess-tako] mit-nun-ta
 John-NOM Sue-ACC smart-PAST-COMP believe-PRES
 ‚John believes Sue to have been smart.‘
- b. Sue-ka [ttoktokha-ess-tako (John-ey uyhay)] mit-e-ci-n-ta
 Sue-NOM smart-PAST-COMP John-by believe-PRES
 ‚Sue is believed to have been smart by John.‘

(Korean; Hong, 2005: 62)

According to Hong (2005), the possibility of passivising the accusative-bearing thematic subject of the embedded clause of the active sentence in (13a) demonstrates that this DP behaves like a regular object. This implies that the embedded subject DP must have moved to the matrix object position, making it possible for the passive rule to apply to it.¹⁷

¹⁶ In addition, (12) also shows that honorific agreement can be established between an honorific DP embedded in a larger DP and the verb. I return to this possibility in chapter 5.

¹⁷ It should be noted that Hong’s argument is only valid if it is assumed that the passive cannot apply to subjects of embedded clauses. However, analyses of ECM-constructions that do not assume subject-to-object Raising and that stipulate that accusative case is assigned to the embedded subject DP across a

Hong's (2005) final argument is based on Principle B-effects. While the embedded subject pronoun in (14a) can be interpreted as co-referential with a matrix subject DP, the same pronoun cannot be co-referential with the matrix subject when it appears with accusative case:

- (14) a. ?John- i_i [ku-ga $_i$ ttoktokha-ess-tako] mit-nun-ta
 John-NOM he-NOM smart-COMP believe-PRES
 ‚John $_i$ believes that he $_i$ is smart.‘
- b. *John- i_i ku-lul $_i$ [t $_i$ ttoktokha-ess-tako] mit-nun-ta
 John-NOM he-ACC smart-COMP believe-PRES
 ‚John $_i$ believes him $_i$ to be smart.‘

(Korean; Hong, 2005: 63)

Hong (2005) suggests that (14a), where it is assumed that the embedded subject DP *ku-ga* is assigned nominative case in the embedded clause by the embedded T is more acceptable because Principle B is not violated. In contrast, (14b), in which the embedded subject DP *ku-lul* is presumed to have raised into the matrix object position to be assigned accusative case, is outright ungrammatical because a pronoun cannot be bound by an antecedent DP that occurs in the same clause.¹⁸

3.1.3 Hyper-ECM in Japanese

Tanaka (2002), following Kuno (1976), suggests that like Greek and Korean, (15a) and (15b) constitute an example of Hyper-ECM in Japanese, and argues for a Raising-to-object analysis of examples such as (15b):

sentence boundary usually explain the “long” passivisation possibility in examples such as (13b) through the defectiveness of the intervening clausal node (a TP, not a CP).

¹⁸ As with the previous argument, Hong's Binding argument is only valid if one excludes the possibility that a matrix subject and the subject of an embedded clause can be in the same Binding domain. However, this assumption has been defended by proponents of ECM-theories which do not assume subject-to-object Raising, where the local domain relevant for Binding is assumed to be extendable if the embedded clause is “defective” and lacks a CP-layer.

- (15) a. John-ga [Bill-ga baka-da-to] omot-teiru
 John-NOM Bill-NOM fool-COP-COMP think-PROG
 ‚John thinks that Bill is a fool.‘
- b. John-ga Bill-o [baka-da-to] omot-teiru
 John-NOM Bill-ACC fool-COP-COMP think-PROG
 ‚John thinks of Bill as a fool.‘

(Japanese; Tanaka, 2002: 637-638)

In the examples in (15), the matrix predicate *omot-teiru* ‚thinks‘ selects a finite indicative complement with an overt complementiser *to* and an embedded finite T-head that is overtly marked for tense (progressive). This means that the T-head should be able to assign nominative case. But while the DP *Bill* is indeed assigned nominative case by the embedded finite T-head in (15a), in (15b), *Bill* is assigned accusative case by the matrix light verb. The examples in (15) therefore show that Japanese also has some predicates that select finite clausal complements whose subjects can be marked with either nominative or accusative case without any adverse effect on grammaticality (see also Hoji 2005 and Kawai 2006).

Tanaka (2002) summarises several arguments originally presented by Kuno (1976) to support the idea that the embedded subject in Japanese Hyper-ECM constructions indeed raises from the embedded subject position of a finite CP to a position where it is assigned accusative case by the matrix light verb.¹⁹ First, Tanaka suggests that an adverbial modifying a matrix predicate may appear after the accusative embedded subject but not after the nominative embedded subject as in (16):

- (16) a. John-ga Bill-o orokanimo [tensai-da to] omot-teiru
 John-NOM Bill-ACC stupidly genius-COP-COMP think-PROG
 ‚John thinks of Bill stupidly as a genius.‘

¹⁹ Notice that in Tanaka’s analysis, the final landing site of DP-movement is not inside the matrix clause, but on the edge of the embedded CP. However, his arguments are also consistent with an analysis according to which the DP undergoes subject-to-object Raising.

- b. *John-ga [Bill-ga orokanimo tensai-da to] omot-teiru
 John-NOM Bill-NOM stupidly genius-COP-COMP think-PROG
 ‚Stupidly, John thinks that Bill is a genius.‘

(Japanese; Tanaka, 2002: 637-638)

Since an adverb is expected to appear in the same clause as the verb it modifies, (16a), in which the adverb *orokanimo* follows the accusative subject DP in the matrix clause, is grammatical. In contrast, (16b), in which the adverb follows the nominative embedded subject, is ungrammatical. This indicates that the accusative subject DP is not in the embedded subject position in the matrix clause.

The second argument has to do with principle B. Similar to Hong’s (2005) argument for Korean Hyper-ECM, Japanese pronouns are subject to principle B; therefore, a pronoun cannot be bound by an antecedent that appears within the same clause as shown in (17):

- (17) a. ?John-ga_i [kare-ga_i baka-da-to] omot-teiru
 John-NOM he-NOM fool-COP-COMP think-PROG
 ‚John_i thinks that he_i is a fool.‘
- b. * John-ga_i kare-o_i [t_i baka-da-to] omot-teiru
 John-NOM he-ACC fool-COP-COMP think-PROG
 ‚John_i thinks of him_i as a fool.‘

(Japanese; Tanaka, 2002:638-639)

The example in (17a) is marginally acceptable because the embedded subject has nominative case, indicating that it is in a different (embedded) clause. Hence, Condition B is not violated. In contrast, (17b), in which the accusative subject of the lower clause is coindexed with the matrix subject DP, is ungrammatical. This suggests that the accusative subject pronoun *kare-o* has raised to the matrix clause.

The third piece of evidence that supports the idea that examples like (15) involve Hyperraising has to do with long-distance scrambling. It has been noted in the literature that Japanese does not allow long-distance scrambling of a subject-DP (Saito, 1985), hence the ungrammaticality of (18):

- (18) *Bill-ga_i John-ga [t_i baka-da-to] omot-teiru
 Bill-NOM John-NOM fool-COP-COMP think-PROG
 ‚Bill, John thinks that is a fool.‘

(Japanese; Tanaka, 2002: 638)

However the raised object in (15b) can undergo scrambling as shown in (19). This is an indication that the accusative subject of the embedded clause is in fact a constituent of the matrix clause:

- (19) Bill-o_i John-ga t_i [t_i baka-da-to] omot-teiru
 Bill-ACC John-NOM fool-COP-COMP think-PROG
 ‚Bill, John thinks that is a fool.‘

(Japanese; Tanaka, 2002: 638)

The fourth piece of evidence has to do with scope ambiguity:

- (20) a. Dareka-ga minna-o mihat-tei-ta
 someone-NOM all-ACC watch-PROG-PAST
 ‚Someone was watching all.‘ (Literal interpretation)
 ‚Someone was watching everybody.‘ (Intended meaning)
- b. Dareka-ga [minna-ga baka-da-to] omot-teiru
 someone-NOM all-NOM fool-COP-COMP think-PROG
 ‚Someone thinks that all are fools.‘

(Japanese; Tanaka, 2002: 638)

Tanaka notes that in (20a), the universal quantifier *minna* ‚all’ appears in the object position with accusative case and is capable of both narrow and wide scope interpretation. In contrast, (20b) in which the universal quantifier appears in the embedded subject position has only the narrow scope interpretation. (21) in which the universal quantifier *minna-o* is assumed to have raised to the object position behaves exactly like (20a) by having both the wide and narrow scope reading (see section 1.6 of chapter 1):

- (21) Dareka-ga minna-o_i [t_i baka-da-to] omot-teiru
 someone-NOM all-ACC fool-COP-COMP think-PROG
 ‚Someone thinks of all as fools.’

(Japanese; Tanaka, 2002: 638)

Tanaka assumes that in (21), the universal quantifier *minna-o* ‚all’ has raised from the embedded subject position to the edge of the embedded CP where it behaves like a matrix object by allowing both readings. Therefore, (21) has both the interpretation in which *dareka-ga* ‚someone’ has scope over *minna-o* as well as the reading in which *minna-o* has scope over *dareka-ga*.

An additional piece of evidence that suggests that the predicate *omot-teiru* triggers Hyper-ECM comes from Bruening (2001). According to Bruening (2001), when part of a Japanese idiom embedded under the predicate *omot-teiru* appears in the matrix clause, the construction still preserves its idiomatic reading:

- (22) a. Taroo-ga [sono-seejika-no kao-ga hiroi to] omotta
 Taroo-NOM that-politician-GEN face-NOM wide COMP thought
 ‚Taroo thought that that politician’s face was wide.’ (Literal interpretation)
 ‚Taroo thought that that politician was well-known.’ (Idiomatic interpretation)

- b. Taroo-ga sono-seejika-no kao-o (orokanimo) [hiroi to] omotta
 Taroo-NOM that-politician-GEN face-ACC (stupidly) wide COMP thought
 Taroo stupidly thought that that politician's face was wide.' (Literal
 interpretation)
 Taroo stupidly thought that that politician was well-known.' (Idiomatic
 interpretation)

(Japanese; Bruening, 2001:11)

Bruening (2001) explains that the fact that part of the idiom can appear before the matrix adverb *orokanimo* ‚stupidly’ when marked with accusative case in (22b) suggests that the idiom chunk has moved out of the embedded clause. And the fact that the sentence in (22b) retains its idiomatic interpretation indicates that the idiom chunk must have originated in the embedded clause.

3.1.4 Hyper-ECM in Turkish

Şener (2008) shows that there is a similar case alternation in Turkish. In certain constructions, the subject of an embedded finite clause can be assigned nominative case by the embedded finite T-head or accusative case by the matrix light verb:

- (23) a. Pelin-Ø [sen-Ø Timbuktu-ya git-ti-n] san-iyor
 Pelin-NOM you-NOM Timbuktu-DAT go-PAST-2SG believe-PRES
 ‚Pelin believes that you went to Timbuktu.’
- b. Pelin-Ø sen-i [Timbuktu-ya git-ti-n] san-iyor
 Pelin-NOM you-ACC Timbuktu-DAT go-PAST-2SG believe-PRES
 ‚Pelin believes that you went to Timbuktu.’

- (24) a. Pelin-Ø [sen-Ø Timbuktu-ya git-ti-n Øiye] bil-iyor-muş/
 Pelin-NOM you-NOM Timbuktu-DAT go-PAST-2SG COMP know-PROG-EVID
 düşün-üyor-muş/ duy-muş
 think-PROG-EVID hear-EVID
 ‚Pelin knew/ thought/ heard that you went to Timbuktu.‘
- b. Pelin-Ø sen-i [Timbuktu-ya git-ti-n Øiye] bil-iyor-muş/
 Pelin-NOM you-ACC Timbuktu-DAT go-PAST-2SG COMP know-PROG-EVID
 düşün-üyor-muş/ duy-muş
 think-PROG-EVID hear-EVID
 ‚Pelin knew/ thought/ heard that you went to Timbuktu.‘

(Turkish; Şener, 2008: 2)

In (23) and (24), the matrix predicates *san-iyor* ‚believe‘, *bil-iyor-muş* ‚know‘, *düşün-üyor-muş* ‚think‘ and *duy-muş* ‚hear‘, subcategorize finite complements which have overt Tense and Agreement with overt complementisers in (24) and without overt complementisers in (23). While the (a) examples have a nominative embedded subject, the (b) examples, whose embedded T-heads also exhibit overt agreement (see section 2.3.2), have an accusative embedded subject. Although the word order in (23) and (24) does not show whether the thematic subjects of the embedded clauses have raised to the matrix clause or remained inside the embedded subject position, the fact that they bear accusative case shows that they are case-marked from outside. At the same time, the agreement between the embedded verb and the DP *sen-i* ‚you‘ shows that at least at some stage in the derivation, this DP must have been inside the embedded subject position. The combination of both observations (case assignment from the matrix clause, and agreement with the embedded predicate) can be interpreted as evidence that (23b) and (24b) are Hyper-ECM constructions.

3.1.5 Hyper-ECM in Herero

Kavari and Marten (2005) show that in Herero, a Bantu language spoken in Namibia and Botswana, the subject of a finite embedded clause can appear before the complementiser

(that is, immediately after the matrix verb with the relevant tense), exhibit attributes of a matrix clause object and bear what Kavari and Marten call “complement case”. Example (25) illustrates:

- (25) òmì-tìrì í-váng-à òvǎ-nátjè kùtjá vé-tjáǵ-é ò-mbàpírà
 9SM-teacher SM9.HAB-want-FV 2ACC-children that SM2-write-SBV 10DC-letter
 ‚The teacher wants the children to write a letter.‘

(Herero; Kavari and Marten 2005: 10)

Kavari and Marten (2005) suggest that in Herero, tone is used to differentiate between cases. The default case on a subject noun is indicated by two low tones on the nominal prefix while the complement case of an object noun is marked by a sequence of low and high tones on the prefix. In Herero, only syntactic object nouns that immediately follow verbs in specific tenses appear with complement case. Importantly, the thematic subject of the embedded clause in (25), the DP *òvǎnátjè* ‚children‘, has complement case, which shows that it is located in an object position in the matrix clause. It also precedes the complementiser.

While the complement case shows that the DP *òvǎnátjè* ‚children‘ in (25) is a matrix object, the fact that in (25), the subject concord marker *vé* on the embedded verb *vétjáǵé* ‚want‘ also agrees with this DP is an indication that the latter must have acted as the subject of the finite embedded clause at some stage of the derivation. But if the matrix object DP originated in the embedded clause, we are again dealing with a Hyper-ECM construction.

3.1.6 Hyper-ECM in Kipsigis

As discussed in chapter 2, section 2.3.4, Jake and Odden (1979) have noted that the Nilotic language Kipsigis is a VSO language in which predicates bear subject/object-verb agreement morphology and subject DPs bear tones that differ from non-subject DPs. Jake and Odden argue that in Kipsigis, verbs such as *mac* ‚want,‘ *yay* ‚make,‘ and *ri:p* ‚watch,‘

trigger raising of a subject DP from the embedded subject position of a finite complement clause to the matrix object position.

- (26) a. Mócè Mùsá [kòlápát kiplàṅàt]
 wants Musa run Kiplangat
 ‚Musa wants Kiplangat to run.‘
- b. Mócè Mùsá kiplàṅàt [kòlápát]
 wants Musa Kiplangat run
 ‚Musa wants Kiplangat to run.‘
- c. Mócè kiplàṅàt Mùsá [kòlápát]
 wants Kiplangat Musa run
 ‚Musa wants Kiplangat to run.‘

(Kipsigis; Jake and Odden, 1979: 134)

In (26a), the embedded subject DP *kiplàṅàt* is marked with subject tone and follows the embedded verb. However, in (26b), the thematic subject of the embedded sentence bears non-subject tone and occurs before the embedded predicate *kòlápát*. Therefore, Jake and Odden (1979) assume that the embedded subject DP *kiplàṅàt* has raised to the matrix object position. In (26c), *kiplàṅàt*, the subject of the embedded clause which now bears non-subject tone can even appear in front of the matrix subject, which serves as further evidence that this DP now appears in the matrix clause.²⁰

Additional evidence provided by Jake and Odden (1979) to show that verbs like *mac* trigger Raising of embedded subject DPs to the matrix object position has to do with object agreement morphology:

²⁰ Kipsigis has a scrambling rule which allows subjects and objects to appear in any word order after the verb (Jake and Odden, 1979:132).

- (27) a. Mócè Mùsá [à- lápát]
 wants Musa 1SG.SUB run
 *,„Musa wants that I run.’ (Literal interpretation)
 „Musa wants me to run.’ (Intended meaning)
- b. Mócó:n Mùsá [à- lápát]
 wants-1SG.OBJ Musa 1SG.SUB run
 „Musa wants me to run.’

(Kipsigis; Jake and Odden, 1979:134)

Jake and Odden (1979) observe that in (27a), the embedded subject appears as a first person singular subject prefix on the embedded verb while there is no object or subject marking on the matrix predicate. But in (27b), not only does the embedded verb bear first person singular subject inflection; the matrix verb also has first person singular object inflection. The fact that the matrix verb in (27b) bears object agreement morphology whose person and number features are the same as those borne by the embedded verb with subject agreement morphology, is an indication that the subject of the embedded clause (a phonologically null pronoun *pro*) has raised to the matrix object position. Put in another way, (27b) suggests that the embedded null subject DP must have originated as the subject of the embedded clause, triggering agreement with the embedded verb, followed by Raising to the matrix object position, where it agrees with the matrix predicate. While the first agreement relation is shown as subject agreement on the embedded verb, the matrix clause agreement relation is reflected overtly by the object agreement morphology on the matrix verb. These data show that Hyper-ECM constructions are characterised by two separate agreement relations, one in which the embedded predicate participates, and one which involves the matrix predicate. My analysis in chapter 6 will correlate this observation with the fact that Hyper-ECM constructions also involve two separate case assignment configurations (as was demonstrated by the Korean data).

Kipsigis Hyper-ECM constructions also test positive for one of the traditional tests for ECM – reflexivization (see section 1.6). In Kipsigis, an object DP that is coreferential with a subject DP within the same clause is realized as *-kê* (Jake and Odden, 1979). An embedded subject that is coreferential with a matrix subject in constructions with *mac* ‘want,’ can be realized as the reflex *-kê*:

- (28) a. ó- móc-è [à- lápát]
 1SG.SUB-want-PROG 1SG.SUB-run
 ‚I want that I run.‘ (Literal interpretation)
 ‚I want to run.‘ (Intended meaning)
- b. ó- mòkcíni-kê [à- lápát]
 1SG.SUB-want-REFL 1SG.SUB-run
 ‚I want myself that I run.‘ (Literal interpretation)
 ‚I want to run.‘ (Intended meaning)

(Kipsigis; Jake and Odden, 1979: 135)

(28a) shows that the embedded subject and the matrix subject are coreferential since both matrix and embedded predicates have the same subject agreement morphology (first person singular subject). Reflexives and their antecedents have to appear within the same clause. In (28b), the fact that the understood subject of the embedded clause is realized as the reflexive suffix *kê* in the matrix clause therefore suggests that the embedded subject has moved to the matrix object position.

3.1.7 Hyper-ECM in Chamorro²¹

Gibson (1992) proposes a Hyper-ECM analysis for Chamorro, an Austronesian language spoken on Saipan and Guam. The predicate *ekspekta* ‘expect’ in (29) is one of a small class of verbs that are assumed to trigger Raising from the subject position of a finite complement clause to the object position of the matrix clause:

²¹ Although Chamorro is an ergative language, the glosses in the literature consulted do not always reflect ergative (ERG) and absolutive (ABS) cases.

- (29) a. Si Lucy ha ekspekta [na si Miguel pära u
 the Lucy 3SG expect COMP the Miguel IRREAL 3SG
 konni' i famagu'un pära eskuela]
 take the children to school
 ‚Lucy expects that Miguel will take the children to school.‘
- b. Si Lucy ha ekspekta si Miguel [pära
 the Lucy 3SG expect the Miguel IRREAL
 u konni' i famagu'un pära eskuela]
 3SG take the children to school
 ‚Lucy expects Miguel to take the children to school.‘
- c. In-ekspekta si Miguel as Lucy [pära
 PASS-expect the Miguel OBL Lucy IRREAL
 u konni' i famagu'un pära eskuela]
 3SG take the children to school
 ‚Miguel is expected by Lucy to take the children to school.‘

(Chamorro; Gibson, 1992: 101; Davies and Dubinsky, 2004: 57)

In (29a), the embedded clause has an overt complementizer *na* and the embedded verb is overtly marked for agreement. The embedded subject DP *si Miguel* appears after the complementiser *na*, which indicates that the embedded subject is in the embedded clause. Example (29b) does not show whether the embedded subject DP *Miguel* is indeed in the matrix clause (as indicated by the bracketing), or whether it is still located in the embedded subject position. However, evidence for the former assumption is provided by the example in (29c), which is the passivised form of (29b). The subject DP *Miguel*, having undergone passivisation, has become the subject of the matrix clause, which suggests that the embedded subject is in the matrix object position in (29b) (but see footnote 15). The fact that the matrix clause in (29b) can be passivised therefore provides evidence that the thematic subject of the embedded clause DP *Miguel* has undergone subject-to-object Raising from a finite clause.

Another piece of evidence that the predicate *ekspekta* triggers movement of the subject DP from the embedded subject position to the matrix object position comes from reciprocal formation in Chamorro.

- (30) *Todu i tiempu um-ä' -ekspekta hām pära bai in atrasao*
 all the time AGR-RECIP-expect 1PL IRREAL 1PL late
 „We always expect each other to be late.’

(Chamorro; Gibson, 1992: 102)

Gibson (1992) observes that since reciprocals are subject to Binding Principle A, the sentence in (30) is grammatical only if it is assumed that *hām*, „each other’ which is understood as the subject of the embedded verb *atrasao*, „late’ is also an object of the matrix verb *ekspekta*, „expect’ at some point in the derivation.

The strongest evidence presented in Davies and Dubinsky (2004) but originally provided by Gibson (1992) to show that (29b) is an example of Hyper-ECM has to do with yes/no question formation in Chamorro. In Chamorro, only intransitive constructions can be used to form yes/no questions. Transitive clauses, in contrast, cannot participate in yes/no question formation:

- (31) a. *Kao ni-li’li’ hao as Juan nigap?*
 Q PASS-see 2SG.ABS OBL Juan yesterday
 „Were you seen by Juan yesterday?’
- b. **Kao ha li’li’ hao si Juan nigap?*
 Q 3SG see 2SG.ABS the Juan yesterday
 „Did Juan see you yesterday?’

(Chamorro; Davies and Dubinsky, 2004: 57)

The structure in (31a) has been passivised, and a passivised clause yields an intransitive construction. Therefore, forming a yes/no question with the question particle *kao* in the passivised structure in (31a), yields the well-formed sentence in (31a). In contrast, adding the question particle to the transitive structure in (31b) generates an ungrammatical sentence. Importantly, forming a yes/no question with the question particle *kao* in constructions involving the transitive use of the predicate *ekspekta* ‚expect,‘ results in ungrammaticality:

(32) a. Kao in-ekspekta hao ni ma'estra pära un na'-funhayan
 Q PASS-expect 2SG.ABS OBL teacher IRREAL 2SG CAUS-finish
 esti na lebblu?
 this of book
 ‚Are you expected to finish this book by the teacher?‘

b. *Kao ha ekspekta hao i ma'estra pära un na'-funhayan
 Q 3SG expect 2SG.ABS the teacher IRREAL 2SG CAUS-finish
 esti na lebblu?
 this of book
 ‚Does the teacher expect you to finish this book?‘

(Chamorro; Davies and Dubinsky, 2004:58)

As expected, (32a) is grammatical because the matrix verb *ekspekta* has been passivised. Since a passivised structure yields an intransitive structure, adding the question particle *kao* to the passivised construction results in a grammatical yes/no question. However, (32b) is ungrammatical. This shows that the thematic subject of the embedded clause is not syntactically located in the embedded clause, since this would make the sentence intransitive and passivisable. Rather, the embedded subject is assumed to have raised to the matrix object position, making the matrix clause an active and transitive clause. Adding the question particle *kao* then produces an ungrammatical sentence. Importantly, the fact that this matrix object still triggers agreement with the embedded verb shows that at some stage of the derivation, it must have been located in the embedded subject position. This means that the data above are clear instances of Hyper-ECM constructions.

3.1.8 Hyper-ECM in Fijian

In Fijian, a VOS-language, the verb *vinakata* ‚want’ appears to trigger movement of the embedded subject *na tagane* ‚the man’ from the subject position of the finite complement to the matrix object position. While the raised DP in (33b) agrees with the embedded predicate, its position between the matrix verb and the matrix subject clearly indicates that it has raised to the matrix object position. This makes these examples clear cases of Hyper-ECM:

- (33) a. E vinakata ko Tamaima [me lako na tagane]
3SG want PROP.ART Tamaima SUBJ-3SG go ART man
‚Tamaima wants the man to go.’
- b. E vinakata na tagane ko Tamaima [me lako]
3SG want ART man PROP.ART Tamaima SUBJ-3SG go
‚Tamaima wants the man to go.’

(Fijian; Massam, 1985: 93-94)

3.1.9 Hyper-ECM in Dholuo

Hyper-ECM is also attested in Dholuo (Gu, 2009):

- (34) A-nen-i [ka i-duaro Pamba]
1SG.SUB-see-2SG.OBJ COMP 2SG.SUB-look-for Pamba
‚I saw you looking for Pamba.’

(Dholuo; Gu, 2009: 6)

In Dholuo, verbs are obligatorily marked with subject/object affixes especially when the subject or object is covert (Gu, 2009: 1). Gu (2009) observes that in (34), the subject affix on the embedded verb *duaro* ‚look’ and the object affix on the matrix verb *nen* ‚see’ mark features of the same pronoun. This suggests that the embedded subject appears first in the embedded subject position before it is attracted into the matrix object position. Therefore the example in (34) also constitutes a clear case of Hyper-ECM.

3.1.10 Hyper-ECM in other languages

There are other languages for which it is claimed that there is Hyper-ECM, because the surface configuration, choice of matrix predicate etc. are parallel to the examples discussed above. However, the relevant literature does not always apply the necessary tests and provide adequate proof to substantiate the claim that the raised DP in these constructions (i) is a genuine syntactic object of the matrix clause, and (ii) has originated as the syntactic subject of the embedded clause. Therefore, I list the data here in a separate section, noting that they potentially provide further support for my claim that Hyper-ECM constructions are abundant in the world's languages.

Jake and Odden (1979) propose a Hyper-ECM analysis for Imbabura Quechua, a highland Ecuadorian Quechua language:

- (35) a. Chai jari-ca cri -n [yachachij warmi-man
that man-TOP believe-3 teacher woman-DAT
wawa-ta cara-ju-y-ta]
baby-ACC serve-PROG-PRES-ACC
'The man believes the teacher is giving the woman the baby.'
- b. Chai jari-ca yachachij-ta crin
that man-TOP teacher-ACC believes
[warmi-man wawa-ta cara-ju-y-ta]
woman-DAT baby-ACC serve-PROG-PRES-ACC
'The man believes the teacher is giving the woman the baby.'

(Quechua; Jake and Odden, 1979: 142)

The embedded clauses in (35) are finite indicative complements with overt progressive tense morphology *-ju*. In the non-Raising variant in (35a), the thematic subject of the embedded clause *yachachij* does not have any overt case marking and is located in the complement clause. Since Quechua is an SOV language, in the Hyper-ECM variant in (24b), the DP *yachachij* is visibly in the matrix object position, because it now appears

before the matrix verb *crin* and bears the accusative suffix *-ta*. This suggests that the embedded subject DP *yachachij* has raised out of the embedded subject position to the matrix object position where it is assigned accusative case by the matrix ECM predicate *crin*. Jake and Odden (1979) suggest that the fact that the accusative embedded subject *yachachij-ta* can be passivised (see section 1.6) and become the matrix subject, is an indication that *yachachij* is no longer in the embedded clause. Rather, it has undergone Raising into the matrix clause, as shown below in (36):

- (36) *yachachij-ca jari cri -shca-mi [warmi-man wawa-ta cara-ju-y-ta]*
 teacher-TOP man believe-PASS-valid woman-DAT baby-ACC serve-PROG-PRES-ACC
 ‚The teacher is believed by the man to be giving the woman the baby.‘

(Quechua; Jake and Odden, 1979:142)

However, in (35), there is no overt agreement between the embedded predicate and the matrix object. Therefore, the data in (35) and (36) should be treated with caution.

Massam (1985) also suggests that in Niuean, the verb *toka* ‚let‘ forces the movement of the subject DP of a finite complement clause to the matrix object position in constructions such as (37) below:

- (37) a. To nākai toka e au [ke kai he pusi e ika]
 FUT not let ERG I SUBJ eat ERG cat ABS fish
 ‚I won’t let the cat eat the fish.‘
- b. To nākai toka e au e pusi [ke kai e ika]
 FUT not let ERG I ABS cat SUBJ eat ABS fish
 ‚I won’t let the cat eat the fish.‘

(Niuean; Massam, 1985: 94-95)

The example is consistent with a Hyper-ECM analysis, according to which the object DP in (37b) receives absolutive case from the matrix predicate, but originates inside the embedded clause. However, in contrast to the examples from Fijian discussed in section 3.1.8, there is no clear evidence that the object DP originates as the thematic subject of the embedded predicate (there is no agreement between the absolutive DP and the embedded predicate). Therefore, the data in (37), like those in (35) and (36) have to be treated with care.

3.2 On (the absence of) Copy ECM

In chapter 2, I have discussed data from languages where long subject-to-subject Raising leaves a gap in the embedded subject position (Hyperraising). I have also provided examples from languages where the embedded subject position in long subject-to-subject Raising has to be occupied by an overt resumptive pronoun (Copy Raising). Since this chapter is concerned with long subject-to-object Raising, and given that I have already presented data of Hyper-ECM, one would expect to find that there are also languages with Copy ECM – i.e. constructions in which the original position of a DP which has raised from an embedded subject position to the matrix object position is obligatorily filled by a pronoun. However, I have not been able to find data from any language which has such a construction.

There are languages in which long subject-to-object Raising with overt resumptive pronouns is attested. Importantly, however, all languages that allow such a construction license the overt resumptive pronoun-strategy as an *alternative to Hyper-ECM*, i.e. all these languages can also represent the base position of the raised subject DP as a simple gap. In chapter 5, I will present the relevant data from languages such as Greek, Korean, Turkish etc., and I will interpret these data as evidence for my claim that the subject “gaps” in Hyper-ECM and Hyperraising constructions are not really gaps, but that the embedded subject position in these examples is filled by unpronounced resumptive pronouns (*pros*). When a language allows resumptive *pro* in Hyper-ECM constructions to

be replaced by an overt pronoun, we are not dealing with Copy ECM constructions in the strict sense.

It is not entirely clear to me at this stage why I have not been able to find languages with genuine Copy ECM constructions. One possibility is, of course, that these constructions exist, but I have simply not been able to find the relevant literature in which these data would have been reported, or alternatively, that the data have not yet been made available in print. It certainly would be premature to deduce the absence of the construction from the absence of the data. It is perhaps not unexpected that Copy ECM constructions are much rarer than Copy Raising constructions, since ECM and subject-to-object Raising generally seems a more marked construction than an “ordinary” subject-to-subject Raising constructions. Therefore, languages which have subject-to-subject Copy Raising may simply not have ECM-constructions of any sort (neither from finite nor from non-finite complements). Yoruba, for example, does not express a sentence such as *John expected her to come* as an ECM-construction:

(38) a. Johanu reti [ki o wa]
John expect COMP 3SG come
,,John expected him/her to come.’

b. *Johanu reti re [ki o wa]
John expect her COMP 3SG come
,,John expected him/her to come.’

(39) a. Johanu gbagbo [pe o lewa]
John believe COMP 3SG beautiful
,,John believes her to be beautiful.’

b. *Johanu gbagbo re [pe o lewa]
John believe her COMP 3SG beautiful
,,John believes her to be beautiful.’

So it is perhaps expected that there are fewer cases of Copy ECM than of Copy Raising languages, and it may not be surprising to find that a language has the latter, but not the former.

The absence of examples from languages in which the embedded subject position in a long ECM construction has to be occupied by a coreferential overt pronominal copy of the raised subject DP is a curious situation. At present, I do not know if the absence of these data reflects a genuine gap in the empirical domain, or a gap in the literature, or if I have simply not been able to find the relevant literature on the relevant languages.

3.3 Conclusion

The foregoing discussion of the literature on ECM constructions shows that there can be exceptional case marking of subjects of finite subjunctive complements in languages like Greek and Rumanian as well as of subjects of finite indicative complements in languages like Korean and Turkish. Depending on the language, different proposals have been made to explain these Hyper-ECM constructions. For example, Kawai (2006) argues that in languages like Japanese, embedded subject DPs in finite indicative complements of ECM predicates are assigned accusative case by the matrix light verb because nominative case is unavailable from the embedded finite clause, which is assumed to be a predicative phrase lacking tense and aspectual inflections and therefore equivalent to a non-finite clause. In contrast to Kawai (2006) Hong (2005) suggests that in languages like Korean, finite embedded clauses are not defective, and that case valuation of an embedded subject DP in a finite indicative complement of an ECM verb can take place optionally. In other words, the case feature of the embedded subject DP may be valued as nominative by the embedded T-head, but case may also be delayed and assigned by the matrix light verb after raising of the embedded subject DP

The important conclusion is that Hyper-ECM constructions are much more common than typically assumed and the theoretical analyses proposed are divergent. On the one hand, one could assume, following Kawai (2006), that accusative case is the result of the non

finiteness of the CP. On the other hand, like Hong (2005), one could argue that the nominative/accusative alternation is entirely optional. Again, as is the case with Hyperraising, the main problems that all theoretical analyses have to solve are: (1) If the embedded clause is finite, why does the subject have to raise and get accusative case from the matrix T? (2) How can case be assigned to an embedded subject DP by a case assigner in the matrix clause given that a CP intervenes between the case assigner and the embedded subject DP?

In the following chapter 4, I discuss some of the theories that have been proposed in the literature on Hyperraising, Copy Raising and Hyper-ECM, and I point out the shortcomings and problems of these proposals.

CHAPTER 4

An overview of existing proposals

In the preceding chapters I have focused on the empirical evidence for the existence of long A-movement constructions that I have collected through an extensive study of the available literature. Before I present my own theoretical analysis of the underlying syntactic mechanisms and relations that allow for the possibility of long A-movement in chapters 5 and 6, I want to discuss and contrast some of the existing proposals that have been made in the literature to explain the relevant data. Rather than discussing each author's analysis individually, I consider it best to group similar or comparable theories together and discuss them from a more general perspective.

There are several competing analyses of Hyperraising and Hyper-ECM. Most of the proposals suggest that Hyperraising is possible because the embedded clause in Hyperraising constructions is somewhat defective despite being a finite CP. However, as I will show, there are also accounts of long A-movement which do not assume defectiveness of the embedded clause. Importantly, these theoretical approaches are mostly motivated by idiosyncratic properties of the respective language under investigation; an account which is based on an idiosyncratic property of a specific language naturally cannot be extended to a language which does not have this property. I consider this the main shortcoming of most existing analyses.

In the following sections, I discuss four main approaches to the analysis of Hyperraising and Hyper-ECM. In section 4.1, I present the analyses that are based on the idea that the embedded finite clause is somewhat defective (because of defective tense and nominal properties of the clause). In section 4.2, I discuss approaches that have to do with the idea that the complement clause is non-defective, but still accessible to elements inside the matrix clause. In section 4.3, I present analyses in support of the view that the complement clause is not a real CP, and in section 4.4, I discuss the base-generation account. Section 4.5 concludes the chapter.

4.1 Raising is possible because the embedded T is defective

In this section I review proposals that assume that, despite the presence of full agreement in the embedded clause, the embedded T-head is defective and therefore incapable of assigning nominative case.

4.1.1 Lack of Tense

In order to explain the possibility of Hyperraising in Greek, Alexiadou and Anagnostopoulou (1999) suggest that nominative case assignment in Greek is not linked to ϕ -feature agreement between T and its subject. They suggest that, although it is possible for a verb to be overtly marked for agreement, nominative case is unavailable to the subject DP if the agreeing T-head does not have the right tense features. Alexiadou and Anagnostopoulou (1999) propose that semantic tense is the feature of T that is responsible for nominative case assignment in languages like Greek.

In this respect, it is relevant that many languages, including Greek, allow Hyperraising out of subjunctive complement clauses (see chapter 2, section 2.2). One typical explanation for Hyperraising constructions with finite subjunctive complements that has been given in the literature is that the subjunctive mood is responsible for the embedded T-head being defective, despite being selected by a finite C-head. Consider the Hyperraising construction from Greek in (1):

- (1) Ta pedhia arxisan [na trexoun.]
the children-NOM started-3PL SUBJ run-3PL
„The children started to run.’

(Greek; Alexiadou and Anagnostopoulou 1999: 5)

Alexiadou and Anagnostopoulou (1999) assume that the defectiveness of the embedded T-head in (1) is due to a lack of tense features. They suggest that the embedded T-head in (1) has not inherited tense features from C. If the tense property of the T-head in the Raising subjunctive complement in (1) is defective, then the case feature of the embedded subject cannot be valued by the defective embedded T-head, and the DP remains an

active goal which can be probed by the matrix T-head. The non-defective matrix T-head values the case feature of the embedded subject, and the embedded subject DP eventually moves to [Spec, T] of the matrix clause.

The suggestion that the T-head in (1) is defective because it lacks tense features is motivated by the observation that generally, subjunctive clauses are assumed to be temporally deficient (Binnick, 1991; Cowper, 2002; Landau, 2004; Nevins, 2004; Boeckx and Hornstein, 2006; Polinsky and Potsdam, 2006). For instance, Alexiadou and Anagnostopoulou (1999) observe that the Greek Raising predicate *arxizo* in (2) selects a complement that does not have an independent tense specification:

- (2) *O eaftos tu arxizi [na ton anisixi avrio]
The self his-NOM begin-3SG SUBJ CL-ACC worry-3SG tomorrow
,,He started being worried about himself tomorrow.'

(Greek; Alexiadou and Anagnostopoulou 1999:12)

Alexiadou and Anagnostopoulou (1999) argue that the example in (2) is ungrammatical because the tense feature of the embedded clause is defective and can therefore not be modified by a temporal adverbial.

Uchibori (2000, 2001) also suggests that in Japanese, Hyperraising out of a subjunctive complement is possible because the tense feature of the embedded T-head of complements such as the one in (3b) below is defective. He suggests that it is the tense-, and not the ϕ -features, of T that are responsible for nominative case assignment in languages such as Japanese. An embedded complement whose tense feature is defective is hence unable to value the case feature of its subject. Uchibori (2000, 2001) observes that although the T-head of the Japanese Raising subjunctive complement has tense morphology, its tense interpretation is restricted in comparison to that of finite non-subjunctive clauses. For instance, non-past stative predicates in non-subjunctive complements can have both a simultaneous and a future reading relative to the matrix

event time. In contrast, the non-past tense of Japanese Raising subjunctive complements is dependent on the matrix tense interpretation. It cannot have a simultaneous or future reading. Compare (3a) and (3b):

- (3) a. Mary-ga [John-ga kyoositu-ni i-ru-to] it-ta
 Mary-NOM John-NOM classroom-in be-NONPAST-COMP say-PAST
 ‚John’s being in the classroom is simultaneous with the time of Mary’s speech in the past.’
 ‚John’s being in the classroom will take place in some future relative to the time of Mary’s speech in the past.’
- b. John-ga_i [t_i kyoositu-ni i-ru-yooni] na-ta
 John-NOM classroom-in be-NONPAST-SUBJ-COMP happen-PAST
 ‚It happened as a natural result that John was in the classroom.’
 = ‚John’s being in the classroom had obtained as a natural consequence from the situation in the past.’

(Japanese; Uchibori, 2001: 8)

While the non-past tense of the T-head embedded under the non-subjunctive clause in (3a) can have both a simultaneous and a future interpretation, the non-past stative verb *i-ru* embedded in the Japanese subjunctive complement in (4b) has neither a simultaneous nor a future reading. The tense interpretation of the Raising complement is dependent on the tense interpretation of the matrix clause. Because the matrix predicate *na-ta* ‚happened’ has a past reading, the embedded clause also gets a past interpretation, regardless of its tense form.

Uchibori (2000, 2001) suggests further that another indication that the tense feature of the Japanese Raising subjunctive complement is defective is its incompatibility with temporal adverbials as in (4):

- (4) *John-ga tuini [_i sungaku-o sakuban benkyoosu-ru-yooni] nat-ta
 John-NOM finally math-ACC last night study-NONPAST-SUBJ-COMP happen-PAST
 ‚Finally, it happened as a natural consequence that last night, John studied Math.‘

(Japanese; Uchibori, 2001: 10)

Uchibori (2000, 2001) suggests that (4) is ungrammatical because the temporal adverbial *sakuban* ‚last night‘ cannot occur in the Raising subjunctive complement because its tense feature is defective.

Contra Chomsky (2000, 2001), Uchibori (2000, 2001) argues that in languages like Japanese, C may select a T that is defective. Uchibori therefore assumes that in Japanese Hyperraising subjunctive constructions, the embedded C selects a defective T. Since a defective T cannot assign nominative case to its subject, it is inevitable that the subject will move out of the CP with defective T to the higher clause with a non-defective finite T-head. Furthermore, Uchibori (2000: 211) suggests that a C that selects a defective T cannot be considered a strong phase. Instead, he adopts the distinction between weak and strong phases introduced by Chomsky (2000) to distinguish between transitive and unaccusative *v* (see chapter 1, section 1.2). According to Uchibori, C is a strong phase head if it selects a T-head with complete ϕ - and tense features. In contrast, a C that selects a defective T-head is a weak phase head.

Alexiadou and Anagnostopoulou’s (1999) and Uchibori’s (2000, 2001) theories seem to account for languages like Greek and Japanese for which it has been argued that tense is the feature of T that is responsible for nominative case assignment. However, this view of nominative case assignment does not straightforwardly account for languages in which complement clauses that allow for Hyperraising in the subjunctive mood are not temporally deficient. For example, Zeller (2006a) shows that the subjunctive complement of the Hyperraising verb *fanele* can have an independent temporal interpretation:

- (5) UJabu u-be-fanele izolo [ukuthi a-hamb-e namhlanje]
 Jabu1a SM1a-AUX-ought yesterday that SM1a-leave- SUBJ today
 'It was vital yesterday for Jabu to leave today.'

(Zulu; Zeller 2006a: 267)

Even if the assumption that semantic tense is the feature responsible for nominative case could account for instances of Hyperraising in languages like Greek or Japanese, where Raising occurs from temporally deficient subjunctive complements, it is unable to explain Hyperraising in languages like Turkish, Hebrew, Yoruba, Igbo, etc. This is because in these languages, the embedded subject DP moves from a finite *indicative* complement whose tense always has an independent temporal interpretation. Consider the Yoruba example in (6):

- (6) òjò jo pé ó ma rò ní òla
 rain seems COMP 3SG will fall at tomorrow
 ‚Rain seems that it will fall tomorrow.’

The embedded clause in (6) is a finite indicative clause with an overt complementiser *pé*. The fact that the embedded clause bears a tense (future) that is different from the one that the matrix clause bears (present), indicates that the embedded tense is not deficient and it can be given its own temporal interpretation, independent of the superordinate clause. Alexiadou and Anagnostopoulou’s (1999) and Uchibori’s (2000, 2001) accounts therefore do not explain why there is Raising out of semantically tensed complements like (6). In chapter 2, I discussed more examples from languages in which Hyperraising occurs from indicative complement clauses with full overt marking of tense and agreement. For instance, in Turkish Hyperraising constructions, there is overt tense and ϕ -feature agreement, yet the embedded subject DP is attracted out of the embedded subject position into the matrix clause (see Moore, 1998, and the examples discussed in section 2.3.2 above)

It also should be mentioned that the idea of an embedded CP with an agreeing but nevertheless defective T-head is at odds with the standard assumption that the availability of nominative case is closely linked to the presence of the C-head, regardless of the semantic or morphological properties of T. While nominative case is assumed to be assigned to a subject DP via ϕ -feature agreement with a T-head (Chomsky, 1998, 2000, 2001), Chomsky (2005: 9) proposes that the non-defective tense and ϕ -features of T are inherited from the phase head C. According to this view, the source of the inflectional features of the clause and the ability to assign case to a subject in [Spec, T] is the C-head. The fact that many of the complements from which Hyperraising and Hyper-ECM are possible are introduced by overt finite complementisers suggests that these CPs are capable of having nominative subjects.

The idea that once a C-head selects a T, the T inherits all the features required for nominative case assignment is supported by examples such as (7a):

- (7) a. The lecturer insists that they be on time.
b. *The lecturer insists that they to be on time.

The grammatical example in (7a), which is similar to that found in Aygen (2004: 64), has a subjunctive embedded clause whose T has neither tense nor agreement morphology, but an overt complementiser *that*. Despite the lack of overt tense and agreement on the verb, the embedded subject is assigned nominative case. This clearly shows that the absence of tense and/or agreement features may not always imply that nominative case is unavailable. Rather, it is assumed that the presence of a C layer guarantees that T inherits all features required to assign nominative case to its subject. In contrast, (7b) is ungrammatical because, in principle, the infinitive *to* lacks the features required to assign nominative case to its subject.

4.1.2 [+N]-clauses

Zeller (2006a) also argues that in Zulu Hyperraising constructions involving *fanele*, the embedded subject DP is unable to have its case feature valued because the categorial

features of the embedded T-head are defective. Following Carlson (1992), Zeller (2006a) argues that there are levels of finiteness and that subjunctives are situated somewhere in the middle between indicatives and infinitives. One of the properties responsible for a decrease in finiteness is ‚noun-ness’. In other words, the more non-finite a clause, the more likely it is to possess or manifest nominal features. In order to explain Hyperraising in Zulu, Zeller (2006a) notes that the ability of a constituent to assign case depends on its category and nominal features may prevent a category from becoming a case-assigner. Hence, verbs and prepositions which are [-N] can assign case, while participles, adjectives and nouns which are [+N] cannot assign case. Zeller (2006a) therefore assumes that the nominal features of the Zulu Hyperraising subjunctive predicates like *fanele* is so strong that the T-heads of the respective subjunctive clauses are unable to value the nominative case feature of an embedded subject DP.

An argument provided by Zeller (2006a) to support the claim that Hyperraising subjunctive predicates in Zulu have strong nominal features is that Hyperraising predicates are not negated like finite indicative verbs in Zulu (which take the negative prefix *a-*; (8)). Instead, they take the negative infix *nga-* and pattern with attributive adjectives and participles when negated:

- (8) Mdu a-ka-lu-theng-i ubisi (indicative)
 Mdu1a NEG-SM1a-OM11-buy-NEG milk
 ‚Mdu is not buying milk.’
- (9) Abantwana be-be-nga-dl-i (participle)
 Child2 AUX-SM2-NEG-play-NEG
 ‚The children were not playing.’
- (10) Uthisha o-nge-m-dala (attributive adjective)
 teacher1a RC1a- NEG-BP-old
 ‚The teacher who is not old.’

- (11) Ku-fanele [ukuthi uMdu a-nga-theng-i imoto le] (subjunctive)
 LOC-ought that Mdu1a SM1a-NEG-buy-NEG car9 DEM9
 ‚Mdu should not buy this car.’

(Zulu: Zeller, 2006a: 268)

Zeller (2006a) assumes that the same property that compels subjunctives to be negated through the insertion of the affix *-nga-* is also accountable for the inability of the embedded subject to have its case feature valued inside the subjunctive complement. Consequently, Zeller (2006a) suggests that in Zulu Hyperraising *fanele* constructions, despite the fact that the embedded T-head has agreement- and tense-features, its nominal features prevent it from valuing the case feature of the embedded subject DP. Furthermore, Zeller (2006a) adopts Uchibori’s distinction between strong and weak phase CPs and argues that subjunctives in Zulu are weak phases. Therefore, the embedded subject is able to have access to nominative case from the non-defective matrix T-head. Agreement between the matrix functional T-head and the embedded subject DP is established, and the EPP subsequently triggers the movement of the embedded subject to the matrix subject position.

Again, the problem with Zeller’s account is that it cannot be extended to languages in which subjunctives do not show the nominal properties attested in Zulu subjunctives, and it has nothing to say about languages in which long A-movement is possible out of indicative clauses. Moreover, Zeller does not address the obvious link between the inability of the embedded T to assign nominative case and the possibility of the embedded subject to agree with the matrix T. Zeller explains the former property through the nominal properties of the subjunctive T, and then simply stipulates that the embedded CP is a weak phase, in order to capture the second property. However, an account of long A-movement constructions should be able to connect these two observations and explain why long Agree-relations can be established in exactly those contexts where they have to be established, namely when the raised DP cannot get case inside the embedded clause.

Finally, let me note another problem with Zeller’s approach that also applies to the other analyses discussed in this section. As was shown in chapter 2, section 2.1.3, the Hyperraising verb *fanele* in Zulu can also appear in a non-Raising construction in which the thematic subject of the embedded clause has remained inside the embedded CP and the matrix clause includes an expletive, (12a):

- (12) a. Ku-fanele [ukuthi amadoda a-hamb-e manje]
 EXPL-ought that man6 SM6-leave-SUBJ now
 „The men ought to leave now.’
- b. Amadoda a-fanele [ukuthi a-hamb-e manje]
 man6 SM6-ought that SM6-leave-SUBJ now
 „The men ought to leave now.’

(Zulu; Zeller 2006b:1)

The assumption that long A-movement is possible because the embedded CP is not a strong phase now clearly faces a challenge: on the one hand, it is assumed that in the Hyperraising construction in (12b), the CP is not a strong phase, because the thematic subject of the embedded clause appears in the matrix clause and agrees with the matrix verb. However, the same DP is licensed inside the embedded clause in (12a), which suggests that in this example, the CP *is* a strong phase and selects a non-defective T that can assign nominative case to the embedded subject. But importantly, there is no indication that the CP in (12a) is in any way different from the CP in (12b), and both CPs are selected by the same matrix verb. The assumption that the CP in (12a) is a phase, but the one in (12b) is not, seems to be a mere stipulation that restates in technical terms the observation that Raising takes place in (12b), but not in (12a).

As far as Hyperraising is concerned, it could be argued that the CP in (12a) is in fact not a strong phase, and that the embedded subject in (12a) does indeed agree with and gets case from matrix T. This would make expletive constructions such as (12a) comparable to English constructions such as *There seem to be people playing in the garden* (see chapter

1, section 1.3), in which the embedded subject DP *people* agrees with and receives nominative case from matrix T. According to this view, the derivations in (12a) and (12b) are almost identical, with the only difference that long-distance agreement and case-assignment between matrix T and the embedded subject is not followed by Hyperraising in (12a), but by expletive insertion.

However, the idea that non-Raising variants of long A-movement constructions involve this sort of “long-distance” agreement and case assignment can only be upheld with respect to the variants of Hyperraising constructions, since the embedded subject DP would be predicted to be marked as nominative in either account (either by the embedded T or by matrix T). In contrast, it can clearly be shown that case-assignment in the non-Raising variant of Hyper-ECM constructions is local. Consider again the Japanese example (15) of chapter 3, repeated in (13):

- (13) a. John-ga [Bill-ga baka-da-to] omot-teiru
 John-NOM Bill-NOM fool-COP-COMP think-PROG
 „John thinks that Bill is a fool.’
- b. John-ga Bill-o [baka-da-to] omot-teiru
 John-NOM Bill-ACC fool-COP-COMP think-PROG
 „John thinks of Bill as a fool.’

(Japanese; Tanaka, 2002: 637-638)

In the Hyper-ECM construction in (13b), the thematic subject of the embedded clause is assigned *accusative* case by the matrix *v*. In (13a), however, the subject DP *Bill* is marked for nominative case, not accusative. This clearly shows that the embedded subject is not assigned case by the matrix *v*, but by T inside the embedded clause. This in turn implies that the CP must be a phase in (13a). But if long A-movement in (13b) is argued to be possible because in this example, the CP is not a phase (as would be implied by an analysis similar to those discussed in this section), then this amounts to the stipulation

that the same CP can sometimes act as a phase, and sometimes not. Without further evidence for such a difference, I consider this a rather stipulative and inelegant solution.

4.2 Case assignment

In this section I discuss proposals which explain long A-movement in terms of a mechanism which allows the embedded subject to receive case in the matrix clause although the embedded T-position is non-defective.

4.2.1 Case delay

Rodrigues (2004) assumes that in Brazilian Portuguese, the case feature of a subject DP is valued through ϕ -feature agreement between a T-head and the subject DP in a Spec-head relation. Consider again the sentences in (40) of chapter 2, repeated here as (14):

- (14) a. E parece [que a Maria está doente]
it seem-3SG that the Maria is-3SG sick
,,It seems that Maria is sick.’
- b. A Maria_i parece [que t_i está doente]
the Maria seem-3SG that is-3SG-PRES sick
,,Maria seems that is sick.’

(Brazilian Portuguese; Rodrigues, 2004: 118)

Rodrigues (2004) suggests that in order for the ϕ -features of the embedded T-head to be valued and deleted, the T-head enters an Agree relation with the subject DP in the [Spec, V] position of the complement clause. Φ -feature agreement between the embedded T-head and the embedded subject DP results in the valuation and deletion of the ϕ -features of the embedded T-head. At this point of the derivation, the subject DP in the embedded [Spec-V] position could be moved to [Spec, T] of the embedded clause to have its case feature valued and deleted by the embedded T-head. But once the case feature of the embedded subject DP is valued and deleted, it will become inactive for any further

syntactic operation. If there is no lexical item in the numeration that can value the ϕ -features of the matrix T-head, then the derivation will not converge. Rodrigues (2004) therefore suggests²² that in order to prevent the derivation from crashing, the valuation of the case feature of the embedded subject DP is *delayed* until the matrix T-head enters the derivation. Once the matrix T-head enters the derivation, it establishes an agreement relation with the embedded subject DP. The complete ϕ -features of the embedded subject DP value the ϕ -features of the matrix T-head and subsequently, the embedded subject DP moves to the matrix subject position where its case feature is valued as nominative by the matrix T-head. The difference between the derivation of (14a) and (14b) is that in (14a), there is a lexical item in the numeration (*e* „it’) that can value and delete the ϕ -features of the matrix T-head, so there is no need to delay the valuation of the case feature on the embedded subject DP *Maria*. In contrast, in (14b), there is no lexical item in the numeration that can value the ϕ -features of the matrix T-head. Therefore, the valuation of the case feature of the embedded subject DP is delayed so that it can remain active in order for it to be able to enter into an agreement relation with the matrix T-head, value the ϕ -features of the T-head and fulfil its EPP requirement. According to Rodrigues, the two derivations in (14) are possible due to the option of delaying case valuation on an embedded subject DP.

A similar proposal is made in Hong (2005). Hong’s account assumes that in Korean, the subject of an embedded finite indicative clause can be assigned either nominative or accusative case, regardless of the presence of tense and/or agreement features on the embedded T. Hong suggests that in constructions where embedded subjects bear nominative case, the case is assigned in the embedded clause by the finite T-head. In contrast, in constructions where the embedded subjects bear accusative case, the embedded subject has to raise out of the embedded finite CP into the matrix clause in order for its case feature to be valued as accusative by the matrix light verb.

²² Rodrigues’ (2004) suggestion that the valuation of the case feature of the embedded subject DP can be delayed until the matrix T-head enters the derivation is similar to Ura’s (1998) suggestion.

Hong (2005) argues that in Korean, in contrast to languages like English, where agreement and case valuation take place simultaneously, agreement between a probe and a goal with matching features may occur without a corresponding case valuation as is illustrated by the Hyperraising-example in (15):

- (15) Halapeci-kkeyse [cengcikha-si-ess-tako [mite-ci-si-n-kes]] kathu-si-ess-ta
 Grandfather-HON.NOM honest- HON-PAST-COMP believe-PASS-HON seem- HON -PAST
 ‚It seemed that it is believed that my grandfather was honest.‘

(Korean; Hong, 2005: 104)

In (15), the subject DP *halapeci* is in agreement with all three finite T-heads. This is signaled by the presence of the honorific morpheme *-si* with all three finite predicates. Hong (2005) suggests that the parametric difference between Korean and languages like English can be captured through a parameter of case valuation that allows case valuation to *optionally* take place through Agree. This parameter allows the case feature of the goal DP *halapeci* to remain unvalued after it values the uninterpretable ϕ -feature of the lowest T-head. Because the goal DP remains active, it proceeds to value the uninterpretable ϕ -feature of the intermediate finite T-head. The goal DP’s case feature remains unvalued and active until it locates the matrix T-head and finally agrees and values the ϕ -features of the matrix finite T-head, while the T-head, in turn, values the case feature of the subject DP *halapeci* as nominative.

As far as Hyper-ECM constructions are concerned, Hong (2005: 122) argues that the matrix light verb of a Korean Hyper-ECM construction carries, in addition to all the features associated with a regular *v*, a focus feature (normally associated with an A-bar position), which makes the light verb position ambiguous between an A and an A-bar position. As a result, the embedded accusative subject is able to move out of the embedded finite clause with an overt complementizer through [Spec, C]²³ before landing

²³ Massam (1985) suggests that there are two positions in the specifier of CP. The inner [Spec, CP] is for WH-elements, while the outer one, considered to be ambiguous between A- and A-bar positions, is assumed to be the landing site of the embedded subject in Hyper-ECM constructions.

in matrix [Spec, v], thereby avoiding a violation of PIC and a ban on improper movement, which prevents an argument that moves from an A-position to an A-bar position from undergoing further A-movement into the higher clause (cf. Chomsky 1973).

The proposals put forward by Rodrigues (2004) and Hong (2005) hence assume that it is a particular characteristic of long A-movement constructions that they allow (for general, or for language-specific reasons) for a case feature not to be valued in a configuration in which nominative case is normally assigned in that language. However, this type of Raising analysis, which allows for Raising to take place optionally, as an alternative to a similar configuration in which nominative case is assigned, does not address the question of which mechanisms are responsible for this sort of optionality. Why can an embedded subject DP move out of a finite CP when it is otherwise possible for it to be assigned nominative case in the embedded clause? What determines that in the same configuration, nominative case is sometimes assigned, and sometimes not? A related problem is that their proposals do not take into account the role of the matrix verbs. Long A-movement is possible only out of CP-complements of Hyperraising or Hyper-ECM-verbs. However, in Rodrigues' and Hong's theories, the question of whether or not a finite T assigns nominative case to the embedded subject must already be decided before the Raising verb is merged. It is not clear how their proposals rule out a derivation in which nominative case is not assigned to the subject DP of an embedded clause which is not selected by a Hyperraising or Hyper-ECM-verb.

Another analysis which is based on similar assumptions is Ura's (1998) account of Copy Raising constructions in Igbo. According to Ura, the sentence in (57b) of chapter 2, repeated here as (16), is derived as follows:

- (16) Ézè_i di m [kà ø_i hũ-rũ Adá]
 Eze seems to me COMP he see-ASP Ada
 ‚lit: Eze seems to me that he saw Ada.‘

(Igbo; Ura, 1998: 68)

Ura assumes that in (16), although the embedded subject DP *Eze* moves from embedded [Spec, v] to embedded [Spec, T] in order to satisfy the EPP features of the embedded T-head, Ura (1998) argues that the embedded subject DP does not enter a checking relation with the ϕ -features of the embedded T. According to Ura, the embedded CP is merged with the matrix V and the derivation of the sentence in (16a) proceeds until it reaches the stage where the matrix T has been merged with the vP to create the matrix T'. The EPP feature of the matrix T now attracts the embedded subject DP to move to the [Spec, T] position of the matrix clause. Only at this stage is the case feature of the subject DP *Eze* valued and deleted by the matrix T. At the same time, the DP values and deletes the ϕ -features of the matrix T-head. However, the ϕ -features of the embedded T are still unchecked. Therefore, Ura (1998) suggests that in order to prevent the derivation from crashing, a language-specific rule provides the embedded [Spec, T] position with a pronominal copy that is spelt out as *o* ‚he‘. This copy values the ϕ -features of the embedded T-head.

One obvious problem of Ura’s account concerns the timing of the various operations he postulates. Ura’s (1998) analysis assumes that the main clause would have been constructed before the intermediate [Spec, T] position could be supplied with a pronominal copy of the matrix subject, which is responsible for valuing and deleting the case-assigning features of the embedded T-head, without which the derivation will crash. This suggestion is problematic because it is countercyclic, and it violates the ‚no tampering‘ condition (Chomsky, 2005, 2007)²⁴, which prohibits the addition of items in the course of the derivation. A related problem with Ura’s (1998) proposal is that the

²⁴ The ‚no tampering condition‘ used to be called ‚inclusiveness‘ under earlier versions of the MP (Chomsky, 1995:225)

embedded CP in Igbo Raising constructions must be a phase – otherwise, we would not expect the embedded T to have a complete set of ϕ -features. However as was explained in chapter 1, section 1.2, once a phase has been completed, the complement of the phase head is transferred in order to be spelt out and is no longer available in the syntax. By the time the derivation reaches the matrix clause, the TP complement of the embedded clause would have been spelt out. It is therefore impossible for the embedded [Spec, T] position to be supplied with a pronominal copy after the matrix clause has been constructed, because of the Phase Impenetrability Condition (PIC).

4.2.2 Case assignment does not inactivate DP

In this section I discuss an account which is comparable to those presented by Ura (1998), Rodrigues (2004) and Hong (2005) in that it assumes that a DP can raise from a clause in which nominative case is in principle available. However, in contrast to the accounts proposed by Ura, Rodrigues and Hong, the analysis that I discuss below assumes that nominative case is in fact assigned to the embedded DP in long A-movement constructions, but that this DP nevertheless remains accessible for further syntactic relations.

Adesola (2005) posits that in Yoruba Copy Raising constructions, the embedded subject DP moves from a potential case position in [Spec, T] of the complement clause to another potential case position in [Spec, T] of the matrix clause, while leaving behind a pronominal copy which shows ϕ -feature agreement with its antecedent. Consider the example in (60) of chapter 2 repeated here as (17):

- (17) a. Ó jọ [pé Olú àti Adé ní owó lọwọ]
 EXPL resemble COMP Olu and Ade have money in hand
 ‚It seems that Olu and Ade are rich.’
- b. [Olú àti Adé]_i jọ pé wón_i ní owó lọwọ
 Olu and Ade resemble COMP they have money in hand
 ‚Olu and Ade seem to be rich.’

(Yoruba; Adesola, 2005: 110-112)

Adesola (2005) argues that the embedded subject DPs in (17) receive case from the embedded T-heads and then raise from the embedded [Spec, *v*] to the embedded [Spec, T] position in order to satisfy the EPP features of the embedded T-heads. In (17a), the embedded subject does not raise any further since there is an expletive in the numeration that is merged in matrix [Spec, TP] to meet the EPP requirements of the matrix T. However, Adesola argues that in (17b), in contrast, where there is no expletive in the numeration, the embedded subject DP, after being assigned nominative case by the embedded T, moves to the matrix subject position to value the EPP features of the matrix T.

Unlike Ura (1998) who clearly states that the raised DP delays getting its case feature valued and deleted until it moves to the [Spec, T] position in the matrix clause, Adesola (2005) argues that in Yoruba Copy Raising Constructions, the embedded subject DP is assigned case by the finite embedded T-head, and yet the embedded DP can still move to the matrix [Spec, T] position. However, Adesola's (2005) assumption that the embedded subject DP gets its case valued in the complement clause creates a problem: according to standard assumptions, once the DP's case feature is valued, it should become inactive for further computation according to minimalist assumptions. Like Ura's proposal, Adesola's (2005) analysis also raises the question of how the embedded subject DP is able to move out of a CP complement clause, since CPs whose T-heads are capable of assigning nominative case are considered to be phases in the Minimalist Program.²⁵

4.3 The embedded clause as a Small Clause

In her analysis of Raising Constructions in Haitian Creole, Deprez (1992) argues that Haitian Creole Copy Raising involves the movement of an embedded subject DP from a finite CP to the matrix subject position. She argues that, unlike "regular" Copy Raising constructions, in which a pronominal copy is left at the point of extraction of the subject

²⁵ Although Adesola (2005: 116) suggests that the Tensed S condition, which prevents A-movement across a CP-boundary, no longer features in the Minimalist Program, the Tensed S condition has been replaced by the PIC, which should capture the same empirical phenomena (see section 1.2).

DP, the raised subject in Haitian Creole does not move from the position of the pronominal copy. In her analysis, (18) is assumed to have the structure in (19):

- (18) Jan sanble [li renmen Mari]
John seems he love Mary
,,John seems to love Mary.'

- (19) [sanble [sc Jan [_{PRED} li renmen Mari]]]

(Haitian Creole; Deprez, 1992: 212)

Deprez assumes that the DP *Jan* is base generated in the subject position of a small clause²⁶, which is the complement of the Raising verb *sanble*. The small clause, in turn, selects a finite complement clause. She explains that the pronoun *li* is unable to satisfy the theta requirement because Haitian pronouns are ambiguous between pronouns and anaphors. As a result, the external theta role of *li* is reassigned to the clausal projection, which turns the whole finite clause into a predicate. This predicate then assigns the theta role to *Jan* via predication (Williams, 1980, 1983, 1986). Subsequently, the embedded subject DP *Jan* moves out of the small clause to the matrix subject position to be assigned nominative case.

Deprez's theory is an attempt to explain data such as (18) without having to assume that long A-movement can exist. Since in principle, it is impossible for a small clause to contain a finite verb or have tense specification, the embedded clause in (18) cannot be considered a small clause because it contains a finite verb *renmen* ',love'. Although (18) seems a clear case of Copy Raising, Deprez effectively re-interprets the finite complement as a non-finite small clause (with a finite clause-like predicate). This allows her to maintain that Raising in (18) is out of a non-finite complement. However, Deprez's analysis has nothing to say about those languages discussed in chapters 2 and 3 in which the complement from which long A-movement is possible is introduced by a complementiser. Furthermore, in the light of the great number of languages which clearly exhibit long A-movement, it is not clear if Deprez's language-specific analysis is actually

²⁶ A small clause is a kind of reduced clause and usually lacks a copula. It is assumed that small clauses do not include tense and inflection (Kawai, 2006; Stowell, 1983, 1989, 1991; Runner, 2006)

needed, given that an independent analysis for Hyperraising, Hyper-ECM and Copy Raising in these languages would still be required.

Kawai (2006) also proposes a small clause analysis for Japanese Hyper-ECM constructions whose embedded subjects bear accusative case. Kawai (2006) argues that the complements of the examples in (20a) and (20b) are homophonous because Japanese has an impoverished verbal morphology. But while the embedded clause in (20a) is a finite CP complement, Kawai (2006) suggests that (20b) is a small clause:

- (20) a. kanojo-wa [sono otoko-ga sagishi da to] shinjiteiru
She-TOP the man-NOM swindler is COMP believes
'She believes that the man is a swindler.'
- b. kanojo-wa sono otoko-o [sagishi da to] shinjiteiru
She-TOP the man-ACC swindler is COMP believes
'She believes the man to be a swindler.'

(Japanese; Kawai, 2006: 329)

The main reason Kawai (2006) proposes a small clause analysis for examples like (20b) is theory-internal. In the Minimalist Program, movement is only allowed as a last resort. In (20a), where the embedded clause is a finite CP, the embedded subject *otoko-ga* is assigned nominative case by the finite T-head; therefore, there is no need for the embedded subject to move to the matrix object position. By arguing that the embedded clause in (20b) is a small clause, Kawai (2006) can maintain that the embedded clause cannot assign nominative case, and that therefore, the embedded subject DP *otoko* has to move out of the embedded clause to the matrix object position where it is assigned accusative case by the matrix light verb. Kawai (2006) suggests that movement out of the embedded clause in (20b) is only possible if it is assumed that the embedded clause in (20b) is a predicative phrase equivalent to a non-finite clause, which lacks tense and aspectual inflections but may host negation. Since non-finite T-heads do not assign

nominative case, it therefore follows that the embedded subject in (20b) would have to move out of the embedded clause in order to have its case feature valued.

Kawai's (2006) small clause analysis seems ad hoc, given that the complement of the non-raised variant in (20a) has the same morphological properties as the complement of the ECM-construction in (20b), yet there is no Raising in (20a). It is similar to the proposals discussed in section 4.1 in that it argues that the embedded clauses from which long A-movement can occur are syntactically different from those in which nominative case is available. However, there is no independent evidence for this difference. In addition, Kawai's (2006) analysis cannot be extended to all the other languages with Hyper-ECM. For instance the example of Hyper-ECM in Greek in (3) of chapter 3, cannot be analyzed as a small clause because the embedded verb is inflected for tense. It contains a copular as well as the past passive participle (Joseph 1976: 244). But if an analysis for the Greek examples is needed anyway, such an analysis can also capture the Japanese data discussed by Kawai, and the language-specific stipulation that identical complements have different syntactic structures is no longer needed.

4.4 Base Generation

In an attempt to address some of the shortcomings of the Copy Raising analysis proposed by Ura (1998) for Igbo, Potsdam and Runner (2001) suggest a base-generation analysis of Raising. Although their theory is developed for English constructions such as (21), for which I have shown above that they are not "genuine" Copy Raising constructions, an approach like theirs could in principle also be adopted for languages with Hyper- or Copy Raising, which is why I discuss it here.

Potsdam and Runner argue that the relation between the ‚raised‘ subject, occupying a non-thematic subject position of a Copy Raising predicate, and the pronominal copy in the embedded subject position does not involve movement. They assume that the copy pronoun originates in the embedded clause, and the matrix subject DP is base generated in the matrix subject position:

(21) [TP Richard_i T seems [XP like [TP he_i T [VP is in trouble]]]]

(Potsdam and Runner, 2001: 462)

According to Potsdam and Runner's (2001) analysis, it is possible to merge a DP directly into the non-thematic position of a Raising predicate. In their analysis, the matrix subject DP *Richard* and the embedded pronominal copy *he* in (21) are assigned a single theta role and form an argument chain, but they independently check the EPP, case and ϕ -features in their respective clauses.

In fact, an analysis which assumes that Hyperraising does not involve movement of the matrix subject has been suggested by Harford (Perez) (1997). Harford proposes that the matrix subject in Kitharaka Hyperraising constructions is base-generated in the matrix subject position, while an empty operator is base-generated in the embedded subject position in order to satisfy the EPP feature of the embedded T. She argues that the empty operator moves to the embedded [Spec, C] position and leaves behind a coindexed copy in the embedded subject position. The empty operator itself is also coindexed with the matrix subject, thereby linking the matrix subject to the embedded subject from which it is then able to inherit its theta role. In her analysis of Hyperraising in Bantu languages, Perez (Harford) (1985) argues that morphological and abstract cases occur together and suggests that the absence of case morphology in Shona, Kiruúndi and Kikuyu is an indication that case theory is not operative in these languages and therefore, the restriction on the occurrence of overt DPs and traces should be accounted for without applying case theory.

In contrast to Hong (2005) and Tanaka (2002), who argue for a Raising-to-object analysis for Korean and Japanese Hyper-ECM constructions with embedded subjects bearing accusative case, Hoji (2005) gives a base generation analysis of constructions with accusative subjects in Japanese:

- (22) John-wa Mary-o Itariazin da to omotteita
 John-TOP Mary-ACC Italian be that thought
 ‚John believed about Mary that she was Italian.‘

(Japanese; Hoji, 2005: 1)

The embedded clause in (22) is a finite complement clause, and the accusative DP *Mary-o* is understood as the subject of this embedded clause. In chapter 3, I have analysed these data as involving long distance agreement and long A-movement to the matrix object position. However, Hoji (2005) suggests that the accusative DP *Mary-o* is base generated in the matrix clause. According to Hoji, at the beginning of the computation, *Mary-o* originates as the object of the matrix predicate and at no stage during the derivation does *Mary-o* appear in the embedded CP.

Hoji’s (2005) main argument for why the accusative DP should be analyzed as base-generated in the matrix object position is again based on the traditional analysis of ECM-constructions, which assumes that “exceptional case marking” only takes place in contexts in which an embedded subject DP is unable to get nominative case from the defective non-finite T-head of an embedded bare TP-complement. Therefore, Hoji (2005) assumes that theoretically, it is not possible for the embedded subject in the Japanese example in (22b) to have moved from the embedded finite (non-defective) CP to a position in the matrix clause where accusative case can be assigned. Hence, Hoji (2005) suggests that the accusative embedded subject in Japanese ECM constructions like (22b) must have originated in the main clause.

These base generation accounts all rely on the unconventional and problematic assumption that it is possible for two syntactic positions to share a single theta role. However, such an assumption raises the question of why this possibility does not exist more frequently, and also in other constructions. For example, if referential argument DPs can essentially play the role of expletives, then one would predict that e.g. English allows sentences such as (23a) with the interpretation of (23b):

- (23) a. *He arrived a man in the city.
b. There arrived a man in the city.

If DPs can be merged into non-theta positions, and be interpreted as coreferential to argument DPs elsewhere in the clause, then (23a) should be possible and equivalent to (23b). However, the ungrammaticality of (23a) suggests that there is independent evidence to maintain the assumption that arguments cannot be merged into non-theta positions. Since the [Spec, T] position in Raising constructions is a non-theta position (which is evident from the possibility of having an expletive in the subject position of a Raising predicate), this implies that an argument cannot be merged directly in that position (Ura, 1994; Chomsky, 2000; Davies & Dubinsky, 2004; Radford, 2004). I therefore continue to assume that the overt subject DPs of Raising and ECM predicates cannot be base-generated in the matrix clause. In order to arrive in matrix positions, they have to have moved from the embedded subject position to their surface position in the matrix clause.

4.5 Conclusion

This chapter has discussed some of the different proposals in the literature as to why Hyperraising, Copy Raising and Hyper-ECM constructions are possible, and why they are necessary. While some authors have suggested that long A-movement occurs because certain features of the embedded T and/or C-heads that are responsible for nominative case assignment are defective, others have suggested that although the features required for assigning nominative case may be present in the embedded clause, case valuation can be delayed or take place optionally, such that the subject DP remains accessible. I have also discussed (and rejected) proposals that assume that the constructions discussed in chapters 2 and 3 do not involve A-movement at all, but are derived by base-generating argument DPs in non-theta positions.

Importantly, as pointed out above, the theoretical approaches that have been suggested are not uniform and applicable to the phenomenon of long A-movement in general.

Rather, they are mostly motivated by the idiosyncratic properties of the respective language under investigation. An account which is based on an idiosyncratic property of a specific language can naturally not be extended to a language which does not have the property. Although it is, of course, not impossible that the Hyperraising and Hyper-ECM constructions in the languages discussed in chapters 2 and 3 are caused by entirely different properties of the respective languages, I find such an assumption rather implausible. Even if it turns out that some of the observable differences between the languages discussed in chapters 2 and 3 are reflexes of the way the possibility of long A-movement is realised in the language, it is still likely that at least some of the processes which give rise to these idiosyncratic properties are also attested in other languages, even if they are not overtly manifested. Therefore, I consider it necessary to at least attempt to provide a unified approach of long A-movement constructions, which explains what is essentially the same phenomenon in terms of the same theoretical assumptions, rather than through different and unrelated theories. As far as I know, such an attempt to provide a cross-linguistically applicable theory of long A-movement has not yet been made in the literature.

In the next chapter, I will present such a theory. In contrast to what is assumed by most analyses discussed above, my proposal is based on the idea that in Hyperraising, Copy Raising and Hyper-ECM-constructions, nominative case is indeed assigned inside the embedded clause, *but not to the DP which has undergone long A-movement*. Rather, I propose, following similar suggestions made for individual languages by e.g. Joseph (1976) and Moore (1998), that in *all* these constructions, the embedded subject position is occupied by a resumptive pronoun, and it is this pronoun which “absorbs” the nominative case assigned by the embedded T. As I will suggest now, this is the reason why the thematic subject argument DP remains caseless inside the embedded clause and is forced to enter a relation with an element in the matrix clause.

CHAPTER 5

Long A-movement and resumption

The discussion in chapters 2 and 3 has shown that languages have long A-movement (understood as subject-to-subject or subject-to-object Raising out of finite clauses). Chapter 4 argued that none of the individual proposals that have been made to explain this possibility of long A-movement in a specific language can easily be carried over to other languages. In this chapter, I therefore want to propose that there is at least one aspect of the grammar of long A-movement that is shared by all languages which permit Hyperraising, Hyper-ECM or Copy Raising. This mechanism is the possibility to have A-movement constructions in which the moved DP leaves behind a resumptive pronoun.

In section 5.1, I discuss an important empirical generalisation. I show that all languages which allow Hyperraising and Hyper-ECM are also ‚null subject’ languages and allow the occurrence of small *pro* (a pronominal without phonetic content) in their subject positions (but not all null subject languages allow Hyperraising). In section 5.2, I suggest on the basis of this generalisation that Hyperraising and Hyper-ECM constructions are instances of long A-movement which leave behind a resumptive *pro*. In section 5.3, I show that the existence of null resumptive pronouns as well as the existence of resumptive pronouns in A-movement constructions has been independently motivated in relation to various constructions discussed in the literature. In section 5.4 I provide empirical evidence for the view that the subject gaps in Hyperraising and Hyper-ECM constructions are (resumptive) *pros*. Finally, section 5.5 discusses the technical implementation of the suggested theory of resumption in long A-movement constructions.

5.1 Ura’s generalisation

From the discussion of the data in chapters 2 and 3, an interesting generalisation emerges. It turns out that one thing that all the languages that allow Hyperraising and Hyper-ECM constructions have in common is that they are “null subject” or “pro drop”-languages. In terms of generative grammar, this means that they license an unpronounced pronominal

DP (small *pro*) in subject position. The following examples show this for the languages discussed in chapter 2, which allow Hyperraising (data without a reference are my own):

- (1) *pro* episa ton yani [pos i Maria vlaføike apo afton]
pro persuaded-1SG the John-ACC that the Maria-NOM hurt-pass-3 SG by him
'I persuaded John that Mary was hurt by him.'

(Greek; Soame and Perlmutter, 1979: 168; section 2.1.1)

- (2) *pro* siken-ni otita
pro exam-DAT failed
'He/she failed the exam.'

(Japanese; Neelman and Szendrői, 2008: 332; section 2.1.2)

- (3) *pro* nu cred să fii bolnav
pro not think.PRES-1SG SUBJ be-2SG sick
'I don't think you are sick.'

(Rumanian; Grosu and Horvath, 1984: 350; section 2.1.4)

- (4) *pro* mi-dun-æ [ke *pro* mi-a-d]
pro DUR-know-1SG that pro DUR-come-3 SG
'I know that he/she is coming.'

(Persian; Darzi, 2008: 111; section 2.1.5)

- (5) *pro* ngi-kath-ele
pro 1SG-tired-PERF
'I'm tired.'

(Zulu; Zeller, 2006: 2; section 2.1.3)

- (6) *pro* nd-agiye
 pro SM-going
 ‚I am going.‘
 (Kiruúndi; section 2.2.1)
- (7) *pro* a-ka-ziya
 pro SM1-PRES-hungry
 ‚He is hungry.‘
 (Shona; section 2.2.1)
- (8) *pro* á-géririe
 pro SM1-try-PAST
 ‚He /she tried.‘
 (Kikuyu; Perez, 1985: 13; section 2.2.1)
- (9) *pro* n-a-in-ir-e.
 pro F-SM-sing-PERF-FV
 ‚S/he sang.‘
 (Kitharaka; Muriungi 2008: 79; section 2.2.1)
- (10) *pro* [sen-i viski iç-ti] bil-iyor-du-m
 pro you-ACC whiskey drink-PAST know-PROG-PAST-1SG
 ‚I knew you to have drunk the whiskey.‘
 (Turkish; Moore, 1998: 169; section 2.2.2)
- (11) *pro* falei com o João ontem a noite
 pro spoke-1SG with the João yesterday at night
 ‚I spoke with João yesterday at night.‘
 (Brazilian Portuguese²⁷; Rodrigues, 2004: 2; section 2.2.3)

²⁷ Although Nevins (2004) claims that Brazilian Portuguese may have lost *pro* due to morphological change, Rodrigues (2004) categorizes Brazilian Portuguese and Finnish as partial pro-drop languages that can drop null referential subjects, but only in restricted environments.

- (12) á-tíl-é *pro*
2 SG-cut-PROG *pro*
„You are cutting.’

(Kipsigis; Jake and Odden, 1979: 131; section 2.2.4)

- (13) *pro* ja:-b:
pro 1SG.MASC/FEM.FUT
„I will go.’

(Bhojpuri; Shukla, 1981: 228; section 2.2.5)

- (14) *pro* kanjian ta le
pro see he PERF
„He/she saw him.’

(Chinese; Neelman and Szendrői, 2008: 332; section 2.2.6)

- (15) mša-t *pro*
went-3SG. FEM *pro*
„She went.’

(Moroccan Arabic; Harrell, 2004: 41; section 2.2.9)

- (16) *pro* paNDLu kon-naa-Du
pro fruit buy-PAST-3SG
„He bought fruit.’

(Telugu; Krishnamurti and Gwynn, 1985: 138; section 2.2.10)

- (17) *pro* a-somo puonj
pro 1SG-study education
„I study education.’

(Dholuo; Gu, 2009: 1; section 2.2.7)

- (18) *pro* istun siä
 pro sit-1SG here
 ‚I am sitting here.‘

(Finnish; Rodrigues, 2004: 3; section 2.2.8)

- (19) *pro* lagaet aich [je ahā gari nai pakair sakab]
 pro seem be-3PRES that you train not catch can
 ‚It seems that you cannot catch the train.‘

(Maithili; Yadava, 1989: 4; section 2.2.10)

The following data illustrate the *pro*-drop character of the languages with Hyper-ECM that were discussed in chapter 3:

- (20) John-i [*pro pro* po-əss-ta-ko] malha-əss-ta
 John-NOM *pro pro* see-PAST-DECL-COMP say-PAST-DECL
 ‚John said he saw someone.‘

(Korean; Huang, 1984: 540; section 3.1.2)

- (21) *pro* mbi-múná òzó-ngòmbè
 pro SC 1SG.HAB-see-FV 10CC-cattle
 ‚I see cattle.‘

(Herero; Kavari and Marten, 2005: 5; section 3.1.5)

- (22) hu yuti' *pro* i bola
 1SG drop *pro* the ball
 ‚I dropped the ball.‘

(Chamorro; Gibson, 1992: 71; section 3.1.7)

- (23) e a tagi *pro*
 3SG PAST cry pro
 ‚He cried.‘

(Fijian; Massam, 1985: 91; section 3.1.8)

- (24) [Juan chaya-shca-ta] yacha-ni *pro*
 Juan arrive-PAST-NOM-ACC know-1SG pro
 ‚I know that Juan has arrived.‘

(Quechua; Cole and Hermon, 1981: 5; section 3.1.10)

- (25) ne hokoko mai a *pro*
 PAST arrive.PL there ABS pro
 ‚They arrived/came there.‘

(Niuean; Haji-Abdolhosseini, Massam and Oda, 2002: 476; section 3.1.10)

As the data show, all languages that were discussed above, which permit A-movement across a CP-boundary which leaves a gap in the embedded subject position are *pro* drop languages. Although not all *pro*-drop languages allow Hyperraising or Hyper-ECM, the opposite implication seems to hold: If a language has Hyperraising or Hyper-ECM, it is also a *pro*-drop language.

This correlation has also been noted by Ura (1994) on the basis of his survey of a subset of the languages discussed in chapters 2 and 3. Ura (1994: 298) captures this correlation in the following generalisation, which I henceforth refer to as “Ura's Generalisation”:

- (26) *Ura's Generalisation* (Ura, 1994: 298)

If a language allows Hyperraising to take place, then it also allows a referential ‚null subject‘. And, if a language disallows a referential ‚null subject‘, then it disallows Hyperraising.

Ura (1994) does not discuss Hyper-ECM constructions, but my data have shown that the generalisation in (26) remains valid even if Ura's term "Hyperraising" is understood as a cover term for both subject-to-subject and subject-to-object Raising out of finite clauses. I conclude that the data discussed in chapters 2 and 3 provide firm empirical support for the idea that a language which allows Hyperraising or Hyper-ECM is always a pro drop language, and I henceforth refer to this idea as Ura's generalisation. It seems justified to postulate that Ura's generalisation is an adequate statement about how two seemingly independent properties of natural languages are correlated. It remains to be seen how this correlation can be explained.

5.2 Hyper-Raising, Hyper-ECM and Copy Raising

Ura (1994) explains the generalisation in (26) by making the following assumptions: (i) in languages which allow Hyperraising and Hyper-ECM, the subject position of finite tensed clauses is a non-case position, and (ii) in these languages, *pro* can be licensed through its ϕ -features and may therefore appear in a non-case position (see Ura, 1994: 310). This means that Ura stipulates a property of subject positions (namely that they are non-case positions) that explains both why a language with this property must have *pro* and why it can have Hyperraising. Assumption (i) provides Ura with an explanation for why an embedded subject must undergo Hyperraising or Hyper-ECM: it cannot get case inside the finite clause, hence it stays active and raises into the main clause where its case feature is valued. Furthermore, Ura argues that because of assumption (ii) only *pro* is allowed in non-case positions, which means that the subject position of a finite clause in languages which do not have *pro* must always be a case position. It follows that Hyperraising and Hyper-ECM are not possible in those languages; according to Ura (1994), the possibility of a referential *pro* which does not need case is therefore a necessary condition for a language to have Hyperraising and Hyper-ECM.

There are various problems with Ura's (1994) analysis. First, it is not clear why the subject position of finite clauses in some languages is a non-case position, despite the fact that subjects in these positions trigger full agreement. As was noted in chapter 1, the

inability of a functional head to value case on a DP is usually associated with an incomplete set of ϕ -features (the absence of person feature). However, if a T-head in a language exhibits full agreement, the assumption that it nevertheless does not value case of the goal amounts to nothing more than a stipulation.

A second problem with Ura's proposal is that it is far from clear how case on a subject can be valued through Hyperraising into the main clause. If the subject position of *all* tensed clauses is a non-case position in languages which allow Hyperraising, as Ura seems to suggest, then raising to a higher subject position does not help the subject to get case. Ura's proposal would only work if it is stipulated that only the subject position of certain embedded clauses is a non-case position. Such proposals have been made elsewhere in the literature and were discussed in Chapter 4. There I have already raised this objection regarding such proposals, which argue that T is defective because of some other property such as e.g. defective tense features, defective categorial features of the embedded T-head, etc. Ura (1994) does not even speculate what the property is that would make embedded clauses defective in the languages he discusses.

Finally, Ura's (1994) analysis does not take into account the obvious correlation between pro drop languages such as e.g. Shona, Greek and Japanese that allow Hyperraising and Hyper-ECM, and non pro drop languages like Yoruba or Igbo which have Copy Raising (see chapter 2 for discussion of these latter languages). It is curious that, although Ura's account attempts to link the pro drop character of the languages under discussion to their Hyperraising status, it does so only indirectly, via the postulation of caseless subject positions. However, Ura's generalisation could be captured more directly, namely by assuming that Hyperraising and Hyper-ECM constructions are possible only in pro drop languages because these constructions *involve the use of a pro-subject*. In other words, Hyperraising and Hyper-ECM constructions are like Copy Raising constructions, but the difference is that in the former languages, the pronominal copy is *pro*.

Based on this idea, I want to put forward an alternative analysis which avoids the problems with Ura's theory but also captures Ura's Generalisation. I suggest that

languages which allow Hyperraising and Hyper-ECM must be pro drop languages because the gap in the subject position of the embedded finite clauses from which Hyperraising and Hyper-ECM has occurred is filled by *pro*. In other words, I argue that the data discussed in chapters 2 and 3, in which an A-moved matrix subject or object is linked to the subject position of an embedded finite clause, are best captured if it is assumed that this embedded subject position is filled with a null subject pronoun which is coreferential with the moved DP. This proposal amounts to saying that A-movement of DPs out of finite clauses triggers *resumption*, i.e. the occurrence of a (null) pronoun in the embedded subject position.

Before I motivate this analysis in sections 5.3 and 5.4, let me show how my alternative proposal explains the core properties of Hyperraising and Hyper-ECM and avoids the problems raised by Ura's proposal. First, in contrast to Ura (1994) and many of the analyses of Hyperraising and Hyper-ECM discussed in Chapter 4, my proposal does not imply that the embedded T-head is defective and that the embedded subject position is a non-case position. Rather, I assume that agreement inside the embedded clause is indicative of the ability of embedded T to license nominative case on the embedded subject. In this respect, no deviation from standard Minimalist assumptions is required. More specifically, I suggest that the role of the resumptive *pro* in Hyperraising and Hyper-ECM is precisely to receive the case assigned by the probing T-head inside the embedded clause. As I will argue below and in Chapter 6, it is the existence of a resumptive pronoun which causes the coreferential subject DP to be without case, which in turn creates a context in which Hyperraising or Hyper-ECM of this DP become possible.

Second, as noted above, my proposal provides an obvious bridge between the languages which allow Hyperraising and Hyper-ECM and those languages with Copy Raising. According to what I suggest here, these constructions are identical in all crucial respects, with the main difference being that the pronominal resumptive copy is a full lexical pronoun in the latter languages, whereas it is a null pronoun in languages with Hyperraising and Hyper-ECM.

5.3 Null resumptive pronouns in A-movement

5.3.1 Null resumptive pronouns

The assumption that null resumptive pronouns exist is not new. Shlonsky (1992) observes that in Standard Arabic relative clauses, when a direct object is relativised, overt agreement in gender and number is reflected on the relative complementiser, as shown in the following examples:

- (27) a. ʔal-rajul-u llaðii raʔaytu-(hu)
 the-man-NOM that.MASC.SG (I) saw-(him)
 „The man that I saw’
- b. ʔal-marʔat-u llatii raʔaytu-(ha)
 the-woman-NOM that.FEM.SG (I) saw-(her)
 „The woman that I saw’
- c. ʔal-ʔawlaad-u llaðiina raʔaytu-(hum)
 the-boys-NOM that. MASC.PL (I) saw-(them.MASC)
 „The boys that I saw’
- b. ʔal-nisaʔ-ʔ-u llawaatii raʔaytu-(hunna)
 the-women-NOM that. FEM.PL (I) saw-(them.FEM)
 „The women that I saw’

(Standard Arabic; Shlonsky, 1992: 457)

Shlonsky (1992) suggests that there is a null resumptive pronoun (a small *pro*) in the direct object positions of the examples in (27) and that the features of this null resumptive pronoun can be recovered from the overt agreement-bearing relative complementisers. This assumption is further strengthened by the fact that overt resumptive pronouns can optionally appear in the object positions in the examples in (27) – the parentheses in the examples in (27) indicate a free alternation between a full resumptive pronoun and a

phonetically null resumptive pronoun. Shlonsky notes that although generally, *pro* is not allowed in the direct object position, this possibility in (27) is due to the fact that the complementiser in Standard Arabic has rich agreement features which makes it possible to fully recover the features of *pro*.

Similarly, Irish and Welsh have prepositions²⁸ that have synthetic forms which reflect overt agreement with relativised objects (McCloskey, 1979; Sells, 1984):

(28) a. An poll aN dtagann na coiníní as
 the hole that come the rabbits out-of-3SG
 ‚the hole that the rabbits come out of’
 (Irish; Sells, 1984:117)

b. Y marched y siaradodd y dynion amdanynt
 the girls that spoke the men about-3PL.FEM
 ‚the girls that the men spoke about’
 (Welsh; Sells, 1984:132)

Sells (1984) observes that in (28a), *an poll* ‚the hole’ is grammatically masculine and the synthetic preposition *as* ‚out-of-it’ agrees with it. Similarly, in (29b), the 3rd person plural form of the Welsh preposition *amdanynt* ‚about them’ agrees with the relativised plural DP *y marched* ‚the girls’.

Irish and Welsh also have possessive pronouns whose objects appear as pronominal clitics on them. These clitics show agreement with these possessor DPs when the latter are relativised:

²⁸ McCloskey (1979) explains that the occurrence of a resumptive pronoun in Irish examples like (28a) is concealed by the idiosyncratic nature of Irish prepositions which are known to incorporate their pronominal objects and vary in structure depending on their form and that of the pronoun.

- (29) a. An fear aN raibh a mhac san ortharlann
 the man that was 3SG.GEN son in- the hospital
 „The man whose son was in hospital’

(Irish; Sells, 1984:117)

- b. Y dyn yr oedd ei fam artref
 the man that was 3SG.GEN mother at-home
 „The man whose mother was at home’

(Welsh; Sells, 1984:132)

In both (29a) and (29b) the pronominal clitics *a* and *ei* ‚his’ agree with the relativised DPs *an fear* and *y dyn* ‚the man’ respectively. Interestingly, it has been suggested by Willis (2000; see also Sells 1984) that the overt agreement on the clitics and the synthetic preposition indicates that the possessor DPs and prepositional objects can be either null pronouns (*pro*) or overt pronouns. Consider the Welsh examples in (30) below:

- (30) a. Y dynion y prynais eu car *pro*
 the men that bought-1SG 3PL-GEN car PRO
 „the men whose car I bought’

- b. Y dynion y prynais eu car nhw
 the men that bought-1SG 3PL-GEN car them
 „the men whose car I bought’

- (31) a. Y dyn y soniais amdano *pro*
 the man that talked-1SG about-3SG.MASC PRO
 „the man that I talked about’

- b. Y dyn y soniais amdano ef
 the man that talked-1SG about-3SG.MASC him
 „the man that I talked about’

(Welsh; Willis, 2000: 538-539)

In the (30a) and (31a), the possessor DP and the prepositional object are realised as *pro* while in (30b) and (31b), they are both realised as overt pronouns. Willis (2000) suggests that the rich agreement morphology reflected by the clitics and the prepositions in Irish and Welsh is brought about as a result of the occurrence of either an overt resumptive pronoun or a null resumptive *pro*. In other words, the fact that the gaps can alternate with full pronouns suggests that the alternative gap is a *pro*.

5.3.2 Resumption in A-movement constructions

The most common cases of resumption discussed in the literature are concerned with A-bar movement. Resumptive pronouns and their distribution in Wh-movement, relative clauses, focus constructions etc. have been extensively investigated (Perlmutter 1972, Kroch, 1981; Zaenen, Engdahl and Maling, 1981; Sells 1984; Engdahl, 1985; Borer 1986; McCloskey, 1990, 2002; Shlonsky 1992; Fox 1994; Pesetsky, 1997, 1998; Sharvit, 1999; Willis 2000; Aoun, Choueri and Hornstein 2001; Ntelitheos, 2002; Boeckx, 2003; Asudeh, 2004; Alexopoulou, 2006; Adesola 2005 etc.).

However, it has also been suggested that resumption can occur in A-movement constructions in languages such as Irish (McCloskey and Sells, 1988). As noted by McCloskey and Sells (1988), while A-bar chains can terminate in either a wh-trace/copy or a null or overt pronominal copy, A-chains are generally not assumed to terminate in null or overt resumptive pronouns. However, McCloskey and Sells (1988) argue that restricting resumption to A-bar movement is an unwelcome stipulation that does not follow directly from the theory.²⁹ Following Rizzi (1986), they suggest the elimination of the asymmetry between A-bar and A-chains by considering the possibility of having A-chains which can either terminate in null or overt resumptive pronouns. They propose that Double Subject Constructions (DSC) and Subject-to-Prepositional object constructions in Irish be analysed as involving A-movement with resumptive pronouns:

²⁹ See also Boeckx (2003: 165f.), who points out that it would be a positive result to find that A-movement also triggers resumption and to extend his „resumption as stranding’ theory to the analysis of Hyperraising and Hyper-ECM constructions. I return to Boeckx’s theory in section 5.5 below.

- (32) a. Níor mhaith liom na páistí eagla a bheith orthu
 I-would-not-like the children fear be-INFIN on-them
 ‚I would not like the children to be afraid.‘

(Irish; McCloskey and Sells 198: 171)

- b. b’éigean don fhear eile gur loiteadh é
 must to-the man other COMP was-wounded him
 ‚The other man must have been wounded.‘

(Irish; McCloskey and Sells 1988:176)

The embedded clause in (32a) seems to have two subjects, the DPs *na páistí* ‚the children‘ and *eagla* ‚fear‘. McCloskey and Sells (1988) analyse this construction by assuming that in the DSC example in (32a), the embedded verb *a bheith* ‚be‘ selects a small clause complement which includes the thematic subject *eagla* ‚fear‘ and the predicate *orthu* ‚on them‘. The second subject DP *na páistí* is located in the clausal subject position ([Spec, T]). The small clause subject *eagla* is then preposed to adjoin to the embedded VP and therefore follows the second subject *na páistí*. In order to explain how the second subject DP *na páistí* is licensed, McCloskey and Sells argue that this DP forms an A-chain with a null resumptive pronoun in the prepositional object position in the small clause, whose presence is signalled by the presence of the synthetic preposition *orthu* ‚on-them‘. In other words, (32a) is analysed as involving A-movement from an object to a subject position which leaves behind a resumptive pronoun. The example in (32b) is assumed to involve another example of an A-chain created by the movement of the DP *fhear eile* ‚other man‘ from the embedded subject position to the matrix prepositional object position. In this construction, long A-movement does not leave a null copy, but an overt resumptive pronoun, in the vacated embedded subject position.

Importantly, the idea that A-movement may leave behind resumptive pronouns has also been put forward in analyses that deal with Hyperraising and Hyper-ECM constructions

and that are indeed very close to the analysis that I propose in my thesis. For example, Joseph (1976) and Soames and Perlmutter (1979: 161-162) argue that in Greek Hyperraising and Hyper-ECM constructions, when an embedded subject DP is raised into the matrix clause, a coreferential pronominal copy of the raised DP is left behind in [Spec, T] of the complement clause. Similarly, in analysing Hyperraising and Hyper-ECM constructions in a variety of Turkish, Moore (1998) suggests that these constructions involve movement of an embedded subject DP that is linked to a silent pronominal copy in the embedded [Spec, T] position, an operation that is similar to the resumptive pronoun strategies used in deriving *wh*-constructions and relative clauses. I return to these analyses in the following section.

5.4 Hyperraising and Hyper-ECM with full pronouns

I have suggested that in Hyperraising and Hyper-ECM constructions, the embedded subject position is filled by *pro*, a pronoun that is given a null spell out at the PF but whose content can be determined or recovered, either through agreement with an inflectionally rich T (in morphologically rich null subject languages like Zulu, Turkish and Greek) or through pragmatic interpretation (in null subject languages like Chinese, Japanese and Korean). Importantly, since *pro* is used as a resumptive pronoun in these constructions, and because the languages under discussion also have overt pronouns, it is expected that at least in some of the languages with Hyperraising or Hyper-ECM, the gap inside the embedded finite clause from which long A-movement has occurred can also be filled with an overt pronoun.

The following data shows that this prediction is borne out with respect to a number of languages. Let me begin with Shona. As Perez (1985) shows, it is possible for the gap in the embedded subject position in Hyperraising constructions like (33a) to be replaced by an overt pronoun, (33b):

- (33) a. Mbavha i-no-fungir-w-a [kuti *pro* y-aka-vand-a mubako]
 Thief₉ SM9-PRES-suspect-PASS-FV that *pro* SM9-PAST-hide-FV in. cave
 „The thief is suspected to be hidden in the cave.’
 (Shona; Perez 1985: 2-4)
- b. Mbavha i-no-fungir-w-a [kuti iyo y-aka-vand-a mubako]
 Thief₉ SM9-PRES-suspect-PASS-FV that (s)he SM9-PAST-hide-FV in. cave
 „The thief is suspected that (s)he is hidden in the cave.’ (Literal interpretation)
 „The thief is suspected to be hidden in the cave.’ (Intended meaning)

According to my proposal, the embedded subject position in both sentences in (33) is filled with a resumptive pronoun, a covert one in (33a) and an overt one in (33b).

Some data presented in Martins and Nunes (2006) also suggest that in Brazilian Portuguese, the embedded gap in Hyperraising constructions can be optionally realised as an overt pronominal copy of the moved subject:

- (34) a. O João parece [que *pro* comprou um carro novo]
 the João seems that PRO bought a car new
 „João seems to have bought a new car.’
- b. O João parece [que ele está doente]
 the João seems that he is sick
 „João seems to be sick.’

(Brazilian Portuguese; Martins and Nunes, 2006: 16-18)

(34b) shows that subject-to-subject Raising out of finite clauses in Brazilian Portuguese can leave behind either *pro* or an overt pronoun.

It should be mentioned that Martins and Nunes (2006) argue that (34b) is syntactically different from the Hyperraising construction in (33a), because they show that overtly realising the embedded pronoun in (34b) blocks the idiomatic interpretation of sentential idioms whose subjects have been raised. However, this difference in interpretation is not unexpected: notice that in many null subject languages, the use of overt pronouns signals an additional semantic or pragmatic interpretation, such as emphasis or contrast (see e.g. Morolong & Hyman 1979; Soames and Perlmutter 1979; Nevins 2005). The absence of an idiomatic reading in cases where *pro* in Hyperraising constructions has been replaced by a full pronoun is therefore not surprising and can be explained by the emphatic nature of overt pronouns, which is not usually compatible with an idiomatic interpretation (see also Nevins (2005: 17) for discussion of this point). In other words, the fact that not every Hyperraising or Hyper-ECM construction in a language allows for the replacement of *pro* by an overt pronoun does not contradict the idea that Hyperraising is the same as Copy Raising with a covert pronoun.

It is also possible for the embedded gap in Hyperraising constructions in Chinese to be optionally realised as an overt pronominal copy of the moved DP, as data from my own fieldwork have confirmed:

- (35) a. John kanqilai [*pro* shi yige shuohuang zhe]
 John seems pro be a liar
 ‚John seems to be a liar.’
- b. John kanqilai [ta shi yige shuohuang zhe]
 John seems he be a liar
 ‚John seems that he is a liar.’ (Literal interpretation)
 ‚John seems to be a liar.’ (Intended meaning)

Yoon (1996) observes that for many speakers of Korean, the embedded gap in Hyper-ECM constructions can be optionally realised as an overt pronominal copy of the moved

subject. My hypothesis that A-chains in Hyperraising and Hyper-ECM constructions terminate in null resumptive pronouns is therefore supported by Yoon's data:

- (36) a. John-un Bill-ul [*pro* maywu yenglihata-ko] sayngkakhanta
 John-Top Bill-ACC PRO very clever-COMP thinks
 „John thinks that Bill is very clever.’
- b. %John-un Bill-ul [ku-ka maywu yenglihata-ko] sayngkakhanta
 John-Top Bill-ACC he-NOM very clever-COMP thinks
 „John thinks that Bill is very clever.’

(Korean; Yoon, 1996: 118)

The use of the full resumptive pronoun in the example in (36b) illustrates another important fact about Hyper-ECM constructions, namely that structural case is indeed available in the embedded subject position. The resumptive overt pronoun is overtly marked for nominative case, which shows that the embedded clause in this example is clearly not defective. It also shows that accusative case assignment to the thematic subject DP and subsequent Raising to object is possible despite the presence of a nominative DP in the embedded subject position.

In light of Yoon's data, it is important to return to an example from Korean presented in Hong (2005) and discussed in chapter 4:

- (37) John-i haksayng-ul [sey myeng-i cengcikha-ess-tako] sayngkakha-n-ta
 John-NOM student-ACC three CL-NOM honest-PAST-COMP think
 „John thinks three students were honest.’

(Korean; Hong, 2005: 85)

Hong (2005) argues that (37) is an example of quantifier stranding. The raised DP *haksayng* originates within the same constituent as the numeral determiner, and strands the determiner in the embedded subject position when moving to the matrix object

position. I agree with Hong's analysis, but I take it one step further. I suggest that *all* cases of A-movement out of finite clauses involve the generation of a complex DP in the embedded subject position which consists of a pronoun and the DP that is interpreted as the thematic subject. The latter DP enters an agreement relation with and receives case from an element in the matrix clause (T, or *v*), and then undergoes A-movement, stranding the pronoun. The pronoun receives nominative case in the embedded clause. While examples such as (37) are the most obvious instances of this configuration, because the moved DP and the stranded pronoun clearly form one constituent and can occur together in other contexts, I argue that examples such as (36) are also derived in this way. While the pronoun that initially merges with the moved DP and that receives nominative case is an overt pronoun in (36b), this pronoun is *pro* in (36a).

Moore (1998) observes that some speakers of Turkish accept Hyperraising examples such as (38b), in which the raised DP is resumed by an overt coreferential pronoun:

- (38) a. siz ban-a [pro git-ti-niz] gibi gel-di-niz
 you-PL-NOM 1-DAT PRO go-PAST-2PL like seem-PAST-2PL
 „You seem to me to have left.”
- b. ?siz ban-a [siz git-ti-niz] gibi gel-di-niz
 you-PL-NOM 1-DAT you-PL-NOM go-PAST-2PL like seem-PAST-2PL
 „You seem to me to have left.”

(Turkish; Moore 1998: 180)

According to Moore (1998), examples such as (38b) are accepted only by a minority of speakers. However, he points out that there are independent reasons for why most speakers reject Hyperraising with overt resumptive pronouns. He notes that for those Turkish speakers who reject data such as (38b), overt coreferential pronouns in embedded clauses are generally prohibited, even in non-Raising contexts:

- (39) a. Asker-ler [savaş-a gönder-il-ecek-ler] san-iyor-lar
 soldier-PL war-DAT send-PASS-FUT-3PL believe-PROG-3PL
 „The soldiers_i believe [they_{i/j} will be sent to war]

- b. Asker-ler_i [onlar*_{i/j} öl-ecek-ler] san-iyor-lar
 soldier-PL they*_{i/j} die-FUT-3PL believe-PROG-3PL
 „The soldiers_i believe [they*_{i/j} will die]

(Turkish; Moore, 1998: 181, quoted from Kornfilt, 1988)

The example in (39) shows that a *pro* DP in an embedded sentence can be interpreted as being bound by a matrix DP. In contrast, an overt pronoun cannot be interpreted as coreferential to the matrix subject by most speakers. Moore (1998) notes that it is exactly those speakers who are capable of interpreting the pronoun and the subject DP in (39b) as coreferential who also accept Hyperraising data such as (38b) with overt resumptive pronouns. This shows again that the impossibility of replacing resumptive *pro* with an overt pronoun in a language may be due to independent reasons that have nothing to do with the structure of long A-movement.

Joseph (1976) also notes that in some contexts, it is possible to have an overt coreferential pronominal copy in the embedded subject position of some Greek Hyper-ECM predicates like *θεωρο* „consider’, as illustrated in (40) below:

- (40) a. Θεωρο ti Maria [pos *pro* ine ekspini]
 consider-1SG Mary-ACC COMP PRO be-3SG smart-NOM-FEM
 „I consider Mary to be smart.’
- b. ?Θεωρο ti Maria [pos afti ine ekspini]
 consider-1SG Mary-ACC COMP she-NOM be-3SG smart-NOM-FEM
 „I consider Mary to be smart.’

(Greek; Joseph, 1976:256)

Joseph (1976) explains that the sentence in (40b) would be awkward unless the overt embedded pronominal subject DP is stressed. In other words, Greek seems to have an

independent language-specific rule which demands that unstressed subject pronouns must be dropped. When an adverb like *mono* ‚only‘ is used in a Hyper-ECM construction with *θeoro* to focus the pronoun, the pronoun must be overtly realised, in order for it to be interpreted as the subject of the sentence, and the sentence with the overt pronoun is no longer marginal, as shown in (41):

- (41) *Θeoro ti Maria [pos mono afti ine ekspini]*
 Consider-1SG Mary-ACC COMP only she-NOM be-3SG smart-NOM-FEM
 ‚I consider only Mary to be smart.‘

(Greek; Joseph, 1976: 258)

Similarly, Soames and Perlmutter (1979:161-162) propose an analysis of Greek Hyperraising and Hyper-ECM constructions which assumes that, when an embedded subject DP is raised into the matrix clause, a coreferential pronominal copy of the raised DP is left behind in [Spec, T] of the complement clause. They also argue that this resumptive pronoun can usually not be overtly realised, because overt pronouns in Greek express emphasis or contrastive focus. If this interpretation is not associated with the embedded subject, *pro* must be chosen (cf. their rule of ‚Subject Pronoun Drop‘).

Similar restrictions may rule out the use of overt resumptive pronouns in other languages with Hyperraising, and produce judgments showing considerable speaker variation. For example, while many speakers of Zulu reject the use of the overt (so-called “absolute”) pronoun *wona* in the Hyperraising construction in (42), the same sentence is marginally acceptable by Ndebele speakers (Ndebele is another Nguni language which is very closely related to Zulu):

- (42) ??Amadoda a-fanele [ukuthi wona a-hamb-e manje]
 man6 SM6-ought that they SM6-leave-SUBJ now
 ‚*The men ought that they leave now.‘ (Literal interpretation)
 ‚The men ought to leave now.‘ (Intended meaning)

Furthermore, Zeller (2006d) reports the possibility of absolute pronouns in Hyperraising constructions in Zulu, on the basis of judgments from his informant:

- (43) UMdu u-fanele [ukuthi yena a-theng-e imoto]
Mdu1a SM1a-ought that he SM1a-buy-SUBJ car
'Mdu, HE must buy a car.'

(Zeller 2006d: 12)

The fact that not all Nguni speakers accept data such as (42) and (43) can again be explained by the additional interpretation associated with overt pronouns in the Southern Bantu languages. For example, as noted by Morolong and Hyman (1977), in Sesotho, absolute pronouns are usually allowed only if they are required for emphatic function. The same holds for the Nguni languages; the emphatic interpretation of the absolute pronoun in (43) is indicated by Zeller's translation. Speakers for whom the *fanele*-construction is incompatible with this emphatic interpretation will not allow the use of overt pronouns in the place of *pro*.

Finally, the fact that the use of overt pronouns in pro drop languages carries additional semantic or pragmatic force also explains an example from Japanese discussed in Ura (1994: 304). Ura presents an example in which inserting an overtly realised coreferential pronoun in embedded [Spec, TP] of a Hyperraising construction yields an ungrammatical sentence in Japanese. When I asked my Japanese informant why overt coreferential pronouns are not allowed in the embedded subject position of Japanese Hyperraising and Hyper-ECM constructions, she said it had to do with the Japanese culture of politeness. When two native speakers are talking, if speaker A thinks speaker B understands what is being talked about, speaker A must drop what is common knowledge. For speaker A (or B) to repeat what seems to be known by the two of them is considered disrespectful behaviour. Generally in pro drop languages, the use of a full pronoun carries additional meaning of contrast and emphasis which tend to blur idiomatic interpretation as opposed to pronouns in non-pro drop languages which do not carry such additional meaning.

In sum, the discussion in this section has shown that there are a number of independent reasons for why full pronouns may not be allowed in the place of *pro* in Hyperraising or Hyper-ECM constructions. At the same time, the fact that many speakers in many of the languages discussed here do allow overt resumptive pronouns in the embedded subject position supports my claim that the “gap” that otherwise appears in long A-movement constructions is not a gap (in the sense of an unpronounced trace/copy of the moved DP), but rather a covert resumptive pronoun. As I will show in chapter 6, the claim that there is a resumptive *pro* in the embedded subject position of Hyperraising constructions is still compatible with a Raising analysis.

5.5 Why resumption?

Having argued that Hyperraising and Hyper-ECM as well as Copy Raising constructions involve long A-movement of an embedded subject which leaves behind a resumptive pronoun, it is now time to consider how this proposal is technically realised.

Consider the configuration in which an unaccusative Raising verb selects a finite CP-complement. In this context, the embedded subject receives case inside the embedded clause, which leaves the ϕ -features and EPP-feature of matrix T unchecked:

(44) [TP [T_{EPP/ ϕ} [*seem* [CP *that* [TP *he*_{Nom} [... *is sick*

In order to make sure that the features of the matrix T can be checked, many languages, including English, use expletive DPs in constructions such as (44). In English, for example, the expletive *it* is merged in the matrix clause; *it* values the ϕ -features of T and checks the EPP when merged in [Spec, T]:

(45) a. [TP ***It*** [T_{EPP/ ϕ} [*seem* [CP *that* [TP *he*_{Nom} [... *is sick*
 b. It seems that he is sick.

The configuration in (45) has only one thematic DP, but two non-defective case positions. In order to maintain a 1:1-relation between DPs and case, languages resort to the use of expletives.

I now suggest that languages with long A-movement have an alternative strategy for configurations such as (45). Instead of using a separate, but semantically vacuous DP to check the features of the matrix probe, these languages allow for the formation of *recursive DPs*, i.e. DPs in which a pronominal head selects another DP:

(46)

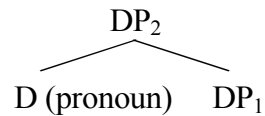

I follow Postal (1966) and Elbourne (2001) in viewing pronouns and definite determiners as the same abstract D-element. I assume that the constructions involving A-movement discussed in chapters 2 and 3 involve the formation of recursive DPs such as (46) in the subject position of embedded finite clauses like the CP in (33). I assume that the theta-role associated with the subject is assigned to the complex DP₂, which includes DP₁. DP₂ also agrees with the embedded T, its case feature is valued as nominative, and the DP moves to [Spec, T]. However, although the whole complex DP₂ counts as the argument of the embedded verb, both DPs need case. Assuming that pronominal DPs are not case assigners, this means that DP₁ still has an unvalued case feature. It therefore is still active, and its ϕ -features are available as the goal for a probe in the matrix clause. Eventually, DP₁ moves out of the embedded clause into the matrix clause, leaving behind the remnant DP₂ and stranding its pronominal head. This stranded resumptive pronoun is *pro* in languages with Hyperraising and Hyper-ECM, or a pronominal copy in Copy raising languages. The structure of this derivation is shown in (47) below:³⁰

³⁰ The structure in (47) shows that A-movement of DP₁ into the matrix clause proceeds via the [Spec, C]-position of the embedded clause. This movement step will be motivated and discussed in more detail in chapter 6.

(47)

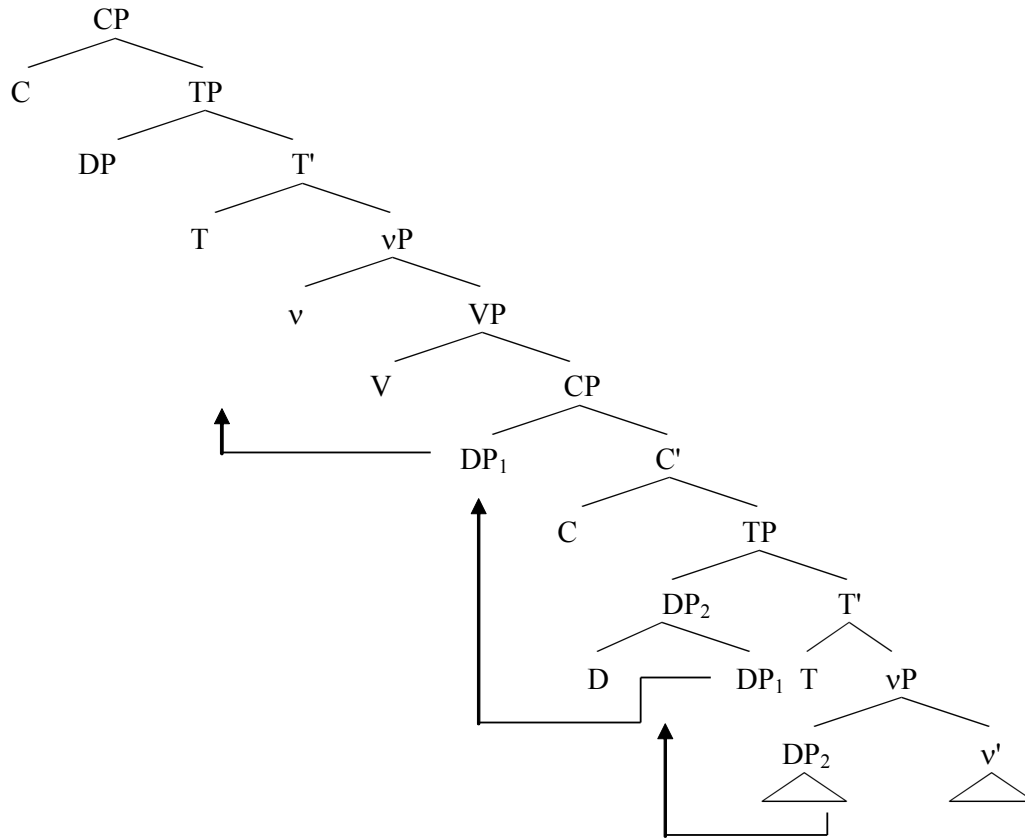

The postulation of structures such as (46) is of course not new.³¹ The idea that a pronominal D can select another full DP, which can then move out of the complex DP, stranding the pronoun, underlies various proposals found in the literature. It has been suggested by Uriagereka (1995) for clitic doubling in Western Romance languages, by Cinque (1977) and Cecchetto (1999, 2000, 2001) for clitic left and right dislocation in

³¹Notice that sub-extraction from a moved constituent is sometimes assumed to be disallowed (Chomsky and Lasnik, 1995; Rizzi, 2004). However, the idea that a material can be extracted from a moved XP has been used in some prominent syntactic theories such as the Raising analysis proposed by Kayne (1994; cf. Bianchi, 2000) for *wh*-relatives with overt relative pronoun in structures such as (i). Kayne (1994) assumes that the derivation of a *wh*-relative involves movement of the complex DP including the relative pronoun and the head noun:

- (i) [DP the [CP[DP[NP car] [DP which *t*]]_i [TP John bought *t*_i]]

In the structure in (i), the complex DP first moves from its base position (as object of the verb *bought*), to [Spec, C]. From here, the NP is sub-extracted out of the DP and further raised into [Spec, D], stranding the relative pronoun inside [Spec, C]. Following Kayne (1994) and others, I henceforth assume that sub-extraction of this sort are licensed by grammar.

Italian, by Escobar (1997) for clitic left dislocation in Spanish and also by Zeller (2009) for clitic left dislocation in Zulu. The idea of generating two DPs under one ‚Big DP’ is also the kind of structure that Boeckx (2003) proposes as the structure underlying resumption in A-bar constructions in natural language. According to this analysis, resumptives are derived from a ‚big’ DP structure in which the lexical DP is merged as the complement of a resumptive pronoun inside the complex subject DP at first merge. (In the following I refer to the DP-complement of the resumptive pronoun as DP_{COMPL}.) While the ‚big DP’ which includes its pronominal head remains in the embedded subject position, DP_{COMPL} escapes and moves to the matrix clause.³²

Notice that Boeckx’s theory of resumption, which I adopt here for A-movement, has an important advantage over other theories of resumption that use mechanisms such as “last resort pronoun insertion” or PF copy spell-out: it does not violate the No Tampering Condition (Chomsky, 2005, 2008), which prohibits the insertion of new elements once the syntactic structure has been derived.

An important point is that, because of the merger of pronominal D and DP₁, there is no lexical category inside DP₁ which could assign an independent theta-role to DP₁. DP₂ does not include a lexical theta-role assigner, in contrast to, for example, complex DPs with possessor DPs, which presumably receive their theta-roles from the noun. As a consequence, DP₁ and DP₂ share the same theta-role, are coreferential, and agree with respect to their feature content, the latter being the result of DP-internal concordial agreement.³³ This is reminiscent of what has been observed in clitic dislocation or clitic

³² It has been suggested by Svenonius (2004), Hiraiwa (2005), and Chomsky (2008), among others, that DP may also be a phase, due to the similarities between CP and DP. This means that it is possible that DP_{COMPL} escapes from the ‚big’ DP through [Spec, D]. If DP_{COMPL} escapes via [Spec, D], then this movement would have to be analysed as A-movement, since the DP will undergo subsequent A-movement to [Spec, C] and then to another A-position in the matrix clause. Note, however, that Boeckx (2003) also assumes that A-bar moved DPs move out of DP through [Spec, D], which suggests that [Spec, D] can serve as both an A- and an A-bar position. See chapter 6 for more discussion of the possibility that specifiers can function as either A- or A-bar positions.

³³ DP-internal agreement is therefore not the result of an Agree-relation, but determined by whatever principles establish concordial agreement between e.g. determiners, adjectives and nouns inside a DP in languages such as e.g. German:

doubling constructions in the Romance languages, in which clitics agree in person, gender, and number with their doubles (Uriagereka, 1995; see also Cecchetto, 1999). Quite generally, merging a ‚big‘ DP into a theta-position hence implies that there will be two DPs (‚big‘ DP, headed by a pronoun, and DP_{COMPL}) in the structures that share the same theta-role. However, since one of these DPs is left without case, it will ultimately appear in a different A-position than the ‚big‘ DP.

One may object that the ‚big‘ DP structure depicted in (46) in which a pronoun is merged with DP_{COMPL} creates binding problems. The head of the ‚big‘ DP C-commands its complement; if the head itself counted as a pronoun in terms of Binding theory, then binding Condition C would be violated. In turn, the head of the ‚big‘ DP is C-commanded by the DP_{COMPL}, which would constitute a Condition B violation. However, note that, in contrast to ordinary pronouns, the pronominal head of the ‚big‘ DP is not a maximal projection. Therefore, the referential index that counts for binding is not on the head *pro* but rather associated with the projection of the head, that is, the ‚big‘ DP. Since the ‚big‘ DP does not C-command the DP_{COMPL}, and is not C-commanded by it, neither Condition C nor Condition B of the Binding theory are violated in (46).

The schematic representation of the derivation of a Hyperraising sentence like (48) is provided in (49) below:

- (48) Amadoda a-fanele [ukuthi a-hamb-e manje]
 man6 SM6-ought that SM6-leave-SUBJ now
 ‚The men ought to leave now.‘

(Zulu; Zeller 2006b: 1)

-
- (i) ein starker Mann
 a-M strong-M man-M
 ‚a strong man‘
 (ii) eine starke Frau
 a-F strong-F woman-F
 (iii) ein starkes Kind
 a-N strong-N child-N
 ‚a strong child‘

(49)

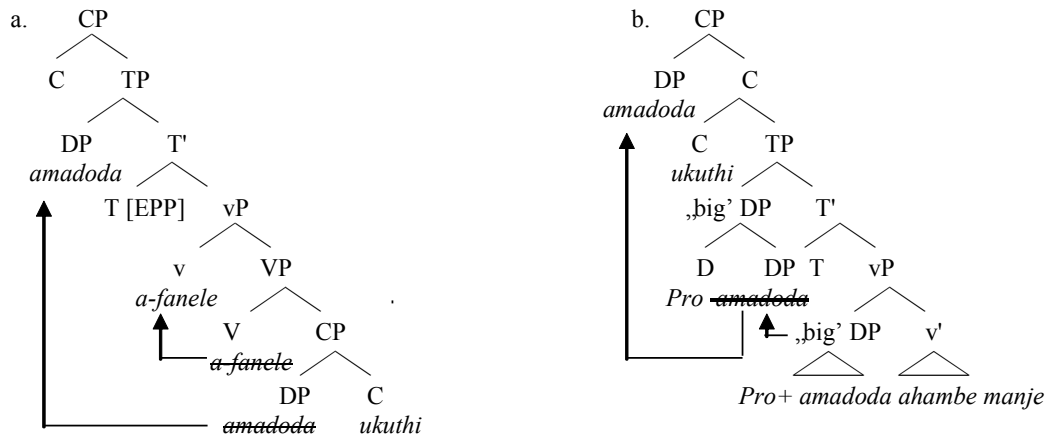

I assume that in the Hyperraising construction in (48), the null resumptive pronoun functions as the head of the „big’ DP and selects the DP_{COMPL} *amadoda* „man’. The „big’ DP itself is merged as the external argument of the embedded light verb *v*. The uninterpretable ϕ -features of the embedded T probe and agree with the „big’ DP *pro* + *amadoda* in [Spec, v]. Nominative case is then assigned to the „big’ DP, and the EPP feature of T causes the „big DP’ to move to embedded [Spec, T]. However, the DP_{COMPL} *amadoda* still has an unvalued case feature and therefore remains an active goal for further Agree-operations. In a next step, the DP_{COMPL} *amadoda* moves from inside the „big’ DP in [Spec, T] to the [Spec, C] position of the embedded clause. I will discuss the trigger for this movement step in the next chapter. For now, it suffices to say that movement of the DP_{COMPL} is motivated by the fact that the embedded CP is a phase, which means that a DP can only be moved out of the CP via the edge of the phase, i.e. [Spec, C].

(49a) shows the movement of the DP_{COMPL} from the embedded [Spec, C] position to the matrix subject position. This movement is a consequence of the Agree-relation that the DP_{COMPL} in [Spec, C] enters with the ϕ -features of matrix T; DP_{COMPL} is eventually attracted by T’s EPP-feature and moves to the matrix [Spec, T]-position.

The proposal that recursive DPs can be formed to allow the generation of "extra" DPs with independent case requirements makes an interesting prediction: Since in the languages with Hyperraising, Hyper-ECM and Copy Raising, a pronominal D can merge with a DP, it is predicted that languages with this option can also apply it recursively and merge a DP such as DP₂ in (46) above with another pronominal D:

(50)

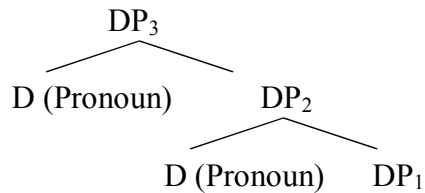

With the appropriate verbs, the possibility of (50) predicts that we also find instances of "successive-cyclic" Hyperraising. Based on my own fieldwork, this prediction seems to be borne out. For example, in the Bantu languages Shona, Kiruúndi and Kikuyu, it is possible to move a subject out of an embedded clause, *through an intermediate clause*, to the matrix subject position in Hyperraising constructions. Consider the example in (51), from Shona:

(51) Vimbai a-no-it-a [sekuti (iye) a-no-fungir-w-a
 Vimbai SM1-PRES-seem-FV that (she) SM1-PRES-thought-PASS-IND
 [kuti (iye) a-ka-ziya]]
 that (she) SM1-PRES-hungry
 ‚Vimbai seems to be thought to be hungry.‘

(Shona)

In (51), we are dealing with two verbs that trigger Hyperraising in Shona, namely the matrix verb *anoita* ‚seem‘ and the passivised verb *anofungirwa* ‚to be thought‘ in the intermediate clause. The thematic subject of the most deeply embedded clause, the DP *Vimbai*, has been moved out of this finite complement clause through the intermediate finite CP into the matrix finite clause. The analysis that I suggested in (49) above now

allows me to make this derivation more precise. I assume that the DP *Vimbai* originates as the DP₁ in a structure like (50). It is a complement of a pronoun which projects DP₂, and DP₂, in turn, acts as the complement of another pronoun which projects DP₃. It is DP₃ which receives the theta-role assigned by the lowest *v* and which moves to the subject position of the lowest clausal complement in (51). What is then extracted from DP₃ is DP₂, which is still a ‚big‘ DP headed by a resumptive pronoun. This DP₂ moves into the subject position of the intermediate clause, where it receives nominative case and triggers agreement with the finite passivised verb. Finally, DP₁ is extracted and moves to the matrix subject position, stranding another resumptive pronoun in the intermediate finite clause. As an “ordinary” successive-cyclic Hyperraising construction, the two resumptive pronouns in (51) would be unpronounced. However, (51) shows that it is also possible in Shona to use overt pronouns as the heads of DP₂ and DP₃. The occurrence of overt pronouns in both embedded subject positions provides strong evidence for the resumptive pronoun-analysis that I have presented in this chapter.

Similarly, successive-cyclic Hyperraising is possible in Kikuyu:

- (52) Mũ-ndũ-mũ-rũme ũ-yũ aro-nekana [átĩ ni óóikaíine
 PERS1-man1 this-1 SM1-appear that FOC SM1-has been known
 [nĩ óórág-íre mũ-ndũ]]
 FOC SM1-kill-PAST PERS1
 ‚This man appears to have been known to have killed a person.‘

(Kikuyu)

As in (51), the subject DP *mũndũmũrũme ũyũ*, which is the thematic subject of the lowest embedded clause, has been moved into the matrix subject position, triggering agreement with all three finite T-heads. The analysis of (51) is on a par with that given for (52). The DP_{COMPL} of the ‚big‘ DP₃ which receives the external theta-role of the most deeply embedded predicate is itself a ‚big‘ DP₂ headed by another resumptive *pro*. DP₂ moves out of the finite complement clause into the intermediate finite CP, stranding the

resumptive *pro* D₃, and then the lowest DP *mũndũmũrũme ũyũ* moves into the matrix finite clause, stranding the null pronoun D₂.

The same derivation is possible in Kiruúndi, as (53) illustrates:

- (53) Yohani a-bonek-a [ko a-a-emer-u-a [ko a-ri umubeshi]]
 John SM1-seems-FV that SM1-PRES-believe-PASS-FV that SM1-be liar
 ‚John seems to be believed to be a liar.’

(Kiruúndi)

As in (51) and (52), the matrix subject position is occupied by the DP₁ *Yohani*, which has stranded the DP₂ headed by a resumptive *pro* in the intermediate finite CP. DP₂ has itself been moved out of the most deeply embedded finite complement clause where it has stranded the ‚big’ DP₃ whose head is another resumptive *pro*. All three DPs trigger noun class agreement with the T-position in their respective finite CPs.

Successive-cyclic Hyperraising also appears to be possible in non-Bantu languages such as Chinese and Japanese:

- (54) John kanqilai [(ta) bei renwei [(ta) shi yige shuohuang zhe]]
 John seems (he) PASS believe (he) be a liar
 ‚John seems that he is believed that he is a liar.’

(Chinese)

- (55) a. John -ga [motto benkyoosu-ru -yooni [omowarete-iru]]
 John-NOM more study-NONPAST-SUBJ COMP think-PASS-be-NONPAST
 nat-ta
 happen-PAST
 ‚It happened as a natural consequence that John is thought to have studied harder.’

- b. John -ga [motto benkyoosu-ru -yooni [nat-ta -to]]
 John-NOM more study-NONPAST-SUBJ COMP happen-PAST-COMP
 omowarete-i-ru
 think-PASS-be-NONPAST
 ‚John is thought to have happened to study harder.’

(Japanese)

In the Chinese example in (54), as well as in both Japanese examples in (55), the overt matrix subject corresponds to the thematic subject of the most deeply embedded clause. The analysis presented above explains this possibility by assuming that the recursive formation of ‚big’ DPs is possible: the overt matrix subject is the DP_{COMPL} of the head of DP_2 , and DP_2 is the complement of the head of DP_3 . DP_2 moves out of the most deeply embedded clause into the intermediate CP, while stranding a pronoun in the most deeply embedded clause. From the intermediate CP, the DP_1 is then attracted into the matrix subject position, stranding another pronoun in the intermediate subject position. Furthermore, the Chinese example again illustrates that both resumptive pronominal heads of the ‚big’ DPs in this derivation can also be realised as overt pronouns.

Finally, (56) presents one example from the literature that illustrates the possibility of successive-cyclic long A-movement in Korean. (56) repeats example (15) from chapter 4:

- (56) Halapeci-kkeyse [cengcikha-si-ess-tako [mite-ci-si-n-kes]] kathu-si-ess-ta
 Grandfather-HON.NOM honest- HON-PAST-COMP believe-PASS-HON seem- HON -PAST
 ‚It seemed that it is believed that my grandfather was honest.’

(Korean; Hong, 2005: 104)

In (56), the matrix subject DP *halapeci*, ‚grandfather’ agrees with all three finite T-heads. This is signaled by the presence of the honorific morpheme *-si* on all three finite predicates. The honorific agreement with both embedded finite T-heads suggests that the

embedded subject DP *halapeci* is raised from the most deeply embedded finite CP, through the immediate finite CP and finally into the subject position of the matrix finite CP.³⁴

5.6 Conclusion

In this chapter, I have argued that long A-movement involves resumption: a DP which crosses an embedded CP-node in order to move to an A-position in a higher clause leaves behind a resumptive pronoun. Furthermore, I have suggested that the resumptive pronoun and the moved DP originate as one constituent. This claim implies that one condition for long A-movement to be possible in a language is that the language must allow the formation of a ‚big’ DP – a DP with a pronominal head that merges with another DP-complement, which is then an accessible goal for a higher probe. Furthermore, I have shown that, if the language is a pro-drop language, then the head of the ‚big’ DP is typically realised as a null pronoun, which superficially creates the impression that the raised DPs in Hyperraising and Hyper-ECM constructions leave behind unpronounced traces/copies in the embedded subject position. However, my analysis has shown that what is left behind is in fact a complex DP whose pronominal head is *pro*. This makes the structure of these languages identical to that of languages with Copy Raising, with the main difference being that the latter languages are not pro drop languages and have to realise the stranded resumptive pronoun overtly.

³⁴ The agreement pattern in (56) shows that not only the ‚biggest’ DP (DP₃) is marked as honorific, but also DP₂ and DP₁. As noted above, the ‚big’ DP structure implies that all ‚big’ DP-internal DP_{COMPLS} agree in terms of their features, as a result of concordial agreement. Each DP then enters an Agree-relation with a different T-head, establishing honorific agreement in all three finite clauses in (56).

CHAPTER 6

The PIC and A-movement to [Spec, C]

In the previous chapter I have argued that Hyperraising, Hyper-ECM and Copy Raising constructions are instances of long A-movement which leave behind a resumptive pronoun. In this chapter, I address the question of exactly how the embedded subject DP undergoes Raising from inside the ‚big‘ DP to the subject or object position in the main clause. This type of long A-movement is not expected to be possible, given that the embedded CP is a finite or tensed clause (see chapter 1).

In section 6.1, I argue against the assumption that the CP in Hyperraising and Hyper-ECM is not a phase. In section 6.2, I challenge the assumption that movement to [Spec, C] is always A-bar movement, and I argue that in Hyperraising, Hyper-ECM and Copy Raising constructions, [Spec, C] can be an A-position. In section 6.3, I suggest that the relevant property of the finite C-head that enables the subject of the finite CP to undergo long A-movement is an uninterpretable inflectional feature uF , which acts as a probe and enters an Agree-relation with an interpretable feature of the lexical subject DP inside the tensed CP. I suggest that movement triggered by an EPP-feature associated with inflectional features counts as A-movement. Raising and ECM-verbs therefore allow long A-movement out of their finite complements by selecting CPs whose heads have uF . I also discuss the nature of the uF of C. In 6.4, I combine these considerations with the conclusions reached in the previous chapter, and I offer a detailed discussion of my complete analysis of long A-movement.

6.1 The Phase Impenetrability Condition and movement to the edge

Even though the analysis of resumption presented in the previous chapter provides an answer to the question why Raising out of finite clauses is *necessary* (due to the presence of a resumptive pronoun, the raised DP lacks case) it does not yet explain why it is *possible*. The problem is of course that in all the examples discussed at length in chapters 2 and 3, DP_{COMPL} (the complement of the resumptive pronoun) undergoes A-movement

out of a finite clause and therefore crosses a finite CP-node when moving to a matrix subject or object position. This kind of movement seems to violate locality conditions on A-movement which have been formulated in various ways, for example as the *Tensed S Condition*, proposed in Chomsky (1973):

- (1) *Tensed S Condition* (Chomsky, 1973: 238)
No rule can involve X , Y in the structure
... X ...[α ... Y ...]... where α is a tensed sentence.

Simply put, A-movement is impossible from a tensed clause. Although it has been suggested that the Tensed S Condition has lost its theoretical relevance in the Minimalist Programme (Ura, 1998; Adesola, 2005), its spirit is still captured clearly by the *Phase Impenetrability Condition* (PIC), which was discussed in chapter 1:

- (2) *Phase-Impenetrability Condition* (Chomsky 2000: 108)
In phase α with head H , the domain of H is not accessible to operations outside α , only H and its edge are accessible to such operations.
- (3) Given $HP = [\alpha [H \beta]]$, take β to be the *domain* of H and α (a hierarchy of one or more Specs) to be its *edge*.

According to Chomsky (2000: 108), phases are CP and vP. Once a CP, for instance, has been completed, its contents are immediately transferred to the interfaces. Only the edge of the phase (that is, its head and its specifier) remains accessible to elements in the next higher phase. Consequently, the subject DP in [Spec, T] of a CP is not available for operations initiated by elements outside the CP. In other words, the subject of an embedded finite CP cannot agree with and receive case from, and cannot be attracted by an EPP-feature of an element in the main clause.

Obviously, despite the PIC, there must be a way for a phrase to undergo long movement out of an embedded finite clause. For example, as is well known, long A-bar movement of wh-phrases is perfectly well-formed in English as well as in many other languages:

(4) *What* do you think that John bought *t*?

The PIC offers a way for the *wh*-phrase in (4) to move from its thematic position in the embedded clause to the matrix [Spec, C]-position. According to (2), a phrase which originates inside a phase α is accessible to operations triggered by probes outside the phase if it is part of the edge of the phase. Since the specifier of the head of a phase is part of its edge, this means that a phrase from inside a CP-phase can be attracted by a higher probe if it is located in [Spec, C] at some stage in the derivation (see (3)). The *wh*-phrase in (4) can therefore be moved into the highest [Spec, C] if it moves there successive-cyclically, via the embedded [Spec, C]-position:³⁵

(5) [_{CP} *What* do you think [_{CP} ~~*what*~~ [that John bought ~~*what*~~]]

There is ample evidence from numerous languages that shows that long A-bar movement to the matrix [Spec, C]-position indeed proceeds successive cyclically, through the specifiers of embedded CPs. Cross-linguistic pieces of evidence in favour of successive-cyclicity come from V-preposing in Spanish (Torrego, 1984); *wh*-agreement in Irish (McCloskey, 2000, 2001, 2002) and Chamorro (Chung, 1982, 1994, 1998); *wh*-copying in German and Frisian (Hiemstra, 1986; Felser, 2004), Afrikaans (Du Plessis, 1977) and Romani (McDaniel, 1989); successive inversion in Belfast English (Henry, 1995); and stranded *all* in West Ulster English (McCloskey, 2000). I am not going to review this evidence here, but I refer the reader to the quoted literature for details. I consider it an established empirical fact that long *wh*-movement targets indeterminate [Spec, C]-positions.

Returning to the discussion of long A-movement, there are now (at least) two possible ways in which the possibility of subject-to-subject or subject-to-object Raising out of finite clauses can be explained, given the PIC. One option, which was already discussed in chapter 4, section 4.1, would simply be to assume that embedded CPs which license

³⁵ Since the two verbs in (4) are transitive, the embedded and matrix vPs are phases as well. The representation in (5) omits the fact that the *wh*-phrase therefore also passes through the edge positions of these two phases (the embedded and the matrix [Spec, v]s) on its way to the topmost [Spec, C].

long A-movement are not (strong) phases. According to such an approach, a Hyperraising construction such as (6) would therefore involve movement of the embedded lexical subject directly from the embedded subject position (where it is the complement of the resumptive pronoun) to the matrix [Spec, T]-position. Example (8b) of chapter 2 is repeated here as (6):

- (6) Amadoda a-fanele [ukuthi a-hamb-e manje]
 man6 SM6-ought that SM6-leave-SUBJ now
 „The men ought to leave now.’

(Zulu; Zeller 2006b: 1)

- (7) [_{CP} amadoda a-fanele [_{CP} ukuthi ~~amadoda~~ a-hamb-e manje]]

Since the matrix verb in (6) is unaccusative (see the discussion in chapter 1, section 1.3), the matrix vP does not count as a phase. By assumption, the intervening CP is not a phase either. Consequently, movement from the embedded [Spec, T] to the matrix subject position in (6)/(7) is possible in one fell swoop.

As was discussed in chapter 4, the idea that CPs which permit long A-movement are not phases has been put forward by e.g. Uchibori (2000, 2001) and Zeller (2006a,b), among others. However, as was also noted in chapter 4, there are various problems with this assumption. For example, as was shown above, many languages allow long A-movement out of indicative complements whose verbs show full agreement and tense specification. However, full agreement and tense are normally only attested with non-defective T-heads. As was noted in chapter 1, Chomsky (2005) suggests that the ϕ -features of non-defective T are inherited from the strong phase head C. Since the embedded T in most cases of Hyperraising, Hyper-ECM and Copy Raising triggers full agreement, the embedded CP must be a phase; attempts to relate the defectiveness of an agreeing embedded T to something else are often language-specific stipulations.

Furthermore, examples from languages which allow Hyper-ECM-constructions with overt resumptive pronouns provide strong evidence against the idea that the finite embedded clauses in these constructions are not phases. As was shown in various places in the preceding chapters, Korean is such a language:

- (8) a. John-un Bill-ul [*pro* maywu yenglihata-ko] sayngkakhanta
 John-Top Bill-ACC PRO very clever-COMP thinks
 ‚John thinks that Bill is very clever.’
- b. %John-un Bill-ul [ku-ka maywu yenglihata-ko] sayngkakhanta
 John-Top Bill-ACC he-NOM very clever-COMP thinks
 ‚John thinks that Bill is very clever.’

(Korean; Yoon, 1996: 118)

Importantly, in constructions in which the raised subject DP is assigned accusative case by the matrix *v*, the overt resumptive pronominal copy in the embedded subject position receives nominative case. This clearly indicates that nominative case is available in the embedded clause from which subject-to-object Raising has taken place. Again, the availability of nominative case is hard to explain if it is assumed that the CP is not a phase.

Another problem with the assumption that CPs which permit long A-movement are not phases is raised by the grammaticality of examples such as (8b):

- (9) a. Θ eoro ton yani [pos ine eksipnos]
 Consider-1SG ACC-John COMP be-SG smart
 ‚I consider John to be smart.’
- b. Θ eoro [pos o yanis ine eksipnos]
 Consider-1SG COMP NOM-John be-SG smart
 ‚I consider John to be smart.’

(Greek; Joseph 1976: 241)

(9a) is another example of a Hyper-ECM construction; (9b) is the corresponding construction without Raising, with the thematic subject inside the embedded clause, and bearing nominative case. As discussed in chapter 4, proponents of theories which postulate that long A-movement is possible because the embedded CP is not a phase now face a dilemma: on the one hand, they have to assume that in the Hyper-ECM construction in (9a), the CP is not a phase. On the other hand, they would have to stipulate that for some reason, the CP in (9b) is a phase, because the embedded subject not only agrees with the embedded T, but also visibly bears nominative case. But there is no indication that the CP in (9b) is in any way different from the CP in (9a), and both CPs are selected by the same matrix verb. The stipulation that the CP in (9b) is a phase, but the one in (9a) is not, seems *ad hoc*.

The alternative explanation for the possibility of long A-movement, and the one that I adopt, is based on the idea that finite CPs are phases, but that a phrase that undergoes Raising out of finite CP also escapes the CP by moving through the edge of the phase, i.e. to [Spec, C]. This proposal is examined in more detail in the following section.

6.2 Successive-cyclic A-movement through [Spec, C]

According to Chomsky (2005, 2006), successive-cyclic movement of a phrase through [Spec, C] is triggered by a so-called *edge-feature* (EF) associated with C, the head of the phase. Edge-features are features of lexical items that allow them to merge with other syntactic objects. In Chomsky (2005), it is assumed that only the edge-features of phase heads can trigger “internal merge” (= movement), although the heads of phrases selected by a phase head can inherit this property. The EPP-feature of T, for example, which triggers movement to [Spec, T], is argued to be derivative from C (Chomsky 2005: 10). The edge-feature of C can trigger movement of a phrase to [Spec, C], a position from which this phrase is accessible to operations in the next higher phase. Adopting this idea for the analysis of long A-movement, I now suggest that in constructions such as (6) and (9a), the embedded CP-head bears an edge feature which attracts DP_{COMPL} from the thematic ‚big’ DP subject to [Spec, C]. Further Raising (to subject or object positions in

the matrix clause) proceeds from this position. This means that I assume that long A-movement never proceeds directly from the embedded subject position to an A-position in the main clause. Rather, I suggest that it always proceeds via the embedded [Spec, C]-position (cf. Lefebvre and Muysken, 1982; Massam, 1985; Yoon, J-M, 1991; Lee, 1992; Tanaka, 2002; Hong, 2005; for similar views):

(10)

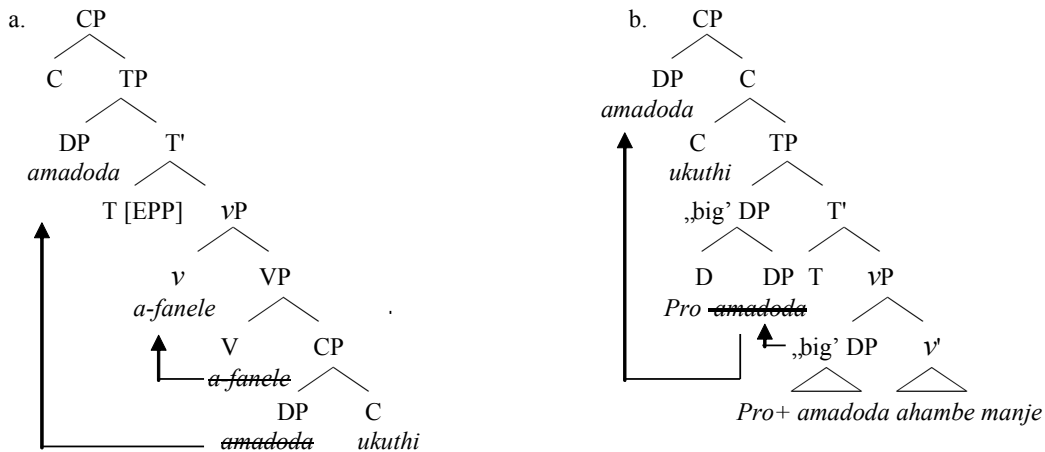

Once the embedded *vP* *amadoda ahambe manje* has been formed, it is merged with T. Since the embedded T is finite and has uninterpretable agreement features, it acts as a Probe and agrees with the „big’ DP, which includes the resumptive *pro* and the DP_{COMPL} *amadoda*. The EPP feature of the embedded T then causes the „big’ DP to raise to the embedded [Spec, T] position. The edge feature of the embedded C then attracts DP_{COMPL} , which moves to [Spec, C], stranding *pro*. Subsequently, the EPP feature of the matrix T attracts the DP_{COMPL} *amadoda* from the embedded [Spec, C] to the specifier position of the matrix T.

There is an obvious problem with the analysis depicted in (10). It has been a long-standing, although not undisputed, assumption in generative grammar that movement to [Spec, C] is always A-bar movement. This assumption is also adopted in Chomsky (2005: 16), where an A-bar position is defined as one that is created through movement of a constituent which has been attracted by the edge-feature of a phase head. If this

assumption is correct, then movement of the DP to [Spec, C] in (10) would count as A-bar movement simply because C is a phase head. The problem that arises is that if movement of a DP to [Spec, C] is A-bar movement, further A-movement of this DP to [Spec, T] or [Spec, v] in the main clause would violate the ban on *improper movement*, which states that A-bar movement cannot be followed by A-movement (see Chomsky, 1973; Müller and Sternefeld 1993; Bruening, 2001; Hong, 2005; Obata and Epstein, 2008). In principle, A'-to-A' (11), A-to-A (12), and A-to-A' (13) movement operations are allowed, but A'-to-A (14) is prohibited:

(11) [CP *Who* did he say [CP ~~*who*~~ [that he talked to ~~*who*~~]]

(12) [TP He can [vP ~~*he*~~ cook rice]]

(13) [CP What did [TP Laura buy ~~*what*~~]]

(14) *[TP Laura seems [CP ~~*Laura*~~ [CØ [TP ~~*Laura*~~ will buy the book]]]]³⁶

Therefore, if movement to [Spec, C] is A-bar movement, then movement of a DP_{COMPL} from the embedded [Spec, CP] position to the matrix subject or object position should result in improper movement.

However, there is no principled reason why movement to [Spec, C] triggered by an edge-feature of C should always count as A-bar movement and cannot be considered A-movement. As noted above, all lexical items which can be merged have edge-features; in fact, Chomsky (2006: 6) notes that "[t]he property of unbounded Merge reduces to the statement that LIs [lexical items] have EF", i.e. it is the edge-features of lexical items that allow them to combine with other lexical items or phrases to derive larger syntactic objects. This means that, in principle, any lexical item can be equipped with an edge-feature which allows other constituents (potentially an unbounded number) to be merged

³⁶ The assumption behind the structure in (14) is that in order to escape the finite clause, the DP *Laura* has to move to [Spec, C] first, but is then prevented from moving to the matrix [Spec, T]-position, because movement from an A-bar position to an A-position is prohibited.

with it. The nature of the operation that merges a constituent in [Spec, C] is therefore not different from the operation that merges a verb with, say, its internal argument. The A-bar-character of this operation also does not follow from the respective constituent undergoing internal (as opposed to external) merge: If internal merge always produced A-bar movement chains, then there could never be any A-movement. Notice that the so-called EPP-feature of T, even if "derivative from C", is the equivalent of an edge-feature, and triggers movement to [Spec, T]. Crucially, this sort of movement is A-movement. The reason that movement to [Spec, C] is typically A-bar movement therefore cannot be found in the nature of the edge-feature of phase heads but must be sought somewhere else.

As noted, Chomsky (2005) seems to try to capture the A-bar- vs. A-movement distinction by stipulating that internal merge *to a phase head* is always A-bar movement, while internal merge *to a non-phase head* is A-movement. Although this stipulation yields the desired result (viz. classifying movement to [Spec, C] as A-bar movement and movement to [Spec, T] as A-movement), I believe that the distinction between these two types of movement does not have to be captured by a stipulation, but can be derived from the feature content of the head whose edge-feature triggers movement. What I propose is that movement triggered by an edge-feature of a head H is A-movement *if the head bears an uninterpretable feature that acts as a probe in an Agree relation*.

Let me illustrate the motivation behind this assumption by comparing ordinary cases of A-bar movement to [Spec, C] with "EPP-driven" A-movement to [Spec, T]. Chomsky (2005) departs from the assumption, adopted in earlier forms of the Principles and Parameters-model (Chomsky, 1993, 1995; Rizzi, 2000), that movement into the so-called "left periphery", which has an interpretative impact in terms of scope and information structure, is triggered by features such as [wh]- or [focus]-features. Rather, Chomsky (2005) suggests that in typical cases of A-bar-movement into the left periphery, the attracting phase head is only equipped with an edge-feature. Any constituent can be attracted by this feature, and the resulting structure is then interpreted by the conceptual-intentional system as an operator-variable construction of some sort. According to this

view, optional edge-features of phase heads drive movement, and this movement serves as the input for semantic interpretation. Movement which is triggered for these reasons, and which is not based on a probe-goal relation between syntactic features of a head and the attracted XP, counts as A-bar-movement.

In contrast, A-movement to [Spec, T] does not feed the semantics, and is instead closely connected to the probe-goal relation between the ϕ -features of T and those of the attracted DP (Chomsky, 1995, 2000, 2001; Pesetsky and Torrego, 2004). Recall that T has inherited its uninterpretable ϕ -features from C; it consequently acts as a probe and enters an Agree-relation with the goal, the interpretable ϕ -features of a DP. When this goal DP is attracted to [Spec, T] by the EPP-feature of T, the result is A-movement. Note that the EPP-feature is in fact an edge-feature,³⁷ but it differs from the edge-feature of C in that it does not attract an XP to establish an operator-variable chain. Rather, T's edge-feature is parasitic on a previously established Agree-relation between a probe and a goal-DP, and if T attracts this goal-DP, the result is A-movement.

I therefore assume that the difference between A-bar-movement and A-movement depends on whether movement is simply triggered by an edge-feature and creates an operator-variable chain, or whether it is correlated with an agreement relation between the attracting head and the moved DP. In the latter case, the movement itself is also triggered by an edge-feature, but I will henceforth use the term “EPP-feature” to refer to the edge-feature of a head which also has grammatical features which act as probes.

In order to explain why movement to [Spec, C] can be A-movement in languages with long A-movement, I now suggest that in these constructions, C has an uninterpretable inflectional feature uF which acts as a probe and enters an agreement relation with the corresponding feature of a goal DP. If the C-head also has an edge-feature (= EPP-feature), movement of the respective DP to [Spec, C] which is triggered by this EPP-feature is like movement to [Spec, T]: it is parasitic on an Agree-relation that has been

³⁷ Or vice versa – the edge-feature of the phase heads C and v was called an EPP-feature in Chomsky (2000).

established between the probe in C and a DP with the respective interpretable feature. My proposal then amounts to saying that long A-movement is possible in languages in which C has uF and an edge/EPP-feature, because this allows the DP-complement of the resumptive pronoun inside the embedded finite clause to escape the phase via A-movement to the edge.

My proposal implies that movement triggered by the edge-feature of a phase head is not always A-bar movement, but may also be an instance of A-movement. Notice that this situation is not only attested with C, but can also be observed with respect to the light verb *v*, another phase head. If *v* simply has an edge feature, and triggers movement of a *wh*-phrase (not necessarily a DP) to the edge of the *v*P-phase, then this movement step may count as A-bar movement. The agreement features of *v* can also be transferred to V, in which case agreement is between V and an object, which can be followed by movement of the object to [Spec, V] (see Zeller 2006c; Chomsky 2008). However, it is possible that in some languages, some of the agreement features of *v* are not transferred onto V, but remain on *v*. The head *v* then agrees with the direct object directly, and its edge-feature may attract the DP to [Spec, *v*]. Since in this latter context, movement to [Spec, *v*] is parasitic on an agreement relation between *v* and the direct object, movement of the latter to [Spec, *v*] should also count as A-movement.

In fact, this seems to be exactly the situation that characterises object shift. It has been suggested by Broekhuis (2007; see also Lee and Cho, 2003; Lee, 2003) that object shift is triggered by the φ -features of *v* coupled with its EPP features. Broekhuis (2007) suggests that in object shift, uninterpretable φ -features of the probe *v* enters an agree relation with the matching interpretable features of the goal object DP in its base position, valuing and deleting its case feature as accusative. Subsequently, the EPP feature of *v* attracts the object DP to its specifier position. Importantly, object shift is generally assumed to be A-movement (Vikner, 1994; Holmberg and Platzack, 1995; Richards, 2004). This means that not all instances of movement to the edge of the *v*P-phase are A-bar movement. The nature of movement to [Spec, *v*] depends on whether or not the edge feature of *v* is also

associated with grammatical features which enter an Agree-relation with the moved phrase.

In sum, the assumption that C may host an uninterpretable inflectional feature which agrees with DP_{COMPL} explains why movement to [Spec, C] may be A-movement and therefore, why long A-movement out of finite clauses is possible. In the next section, I discuss the nature of the relevant inflectional feature of C, and the resulting Agree-relation, in more detail.

6.3 Resumption, the EPP, and long A-movement

6.3.1 C and inflectional features

As was discussed in chapter 1, the standard approach to Raising and ECM-constructions assumes that the clausal complement of Raising and ECM-verbs is “defective”; i.e. it lacks a CP-layer and projects only up to the level of TP. It is clear that not all verbs in a language are allowed to merge with such defective clauses; rather, it must be an exceptional property of Raising and ECM-verbs that they select bare TP-complements, and a respective selectional feature must be captured as part of the lexical entries of these verbs.

The same considerations apply to verbs in languages which allow long A-movement. The verbs which license Hyperraising, Hyper-ECM or Copy Raising in these languages must be able to select finite CPs which exceptionally allow for an embedded subject to move out of CP and to undergo further A-movement into the main clause. A head typically selects the head of its complement and its morphological properties (Grimshaw, 1979; Svenonius, 1994; Matushansky, 2006). It follows that it must be a particular morphological property of the complementiser position which makes long A-movement possible, and it is this property of the C-head that is selected by Raising and ECM-verbs. I now suggest that the relevant property of the finite C-head that enables the subject of the finite CP to undergo long A-movement is the uninterpretable inflectional feature uF

which acts as a probe and enters an Agree-relation with the corresponding interpretable feature of the lexical subject DP_{COMPL} inside the tensed CP. If the C-head also has an EPP-feature – i.e. the regular edge-feature of C, now attracting the DP which participates in an Agree-relation with the probe of C – then movement to [Spec, C] counts as A-movement. Raising and ECM-verbs therefore enable long A-movement out of their complements by selecting CPs whose heads have uF. A DP which agrees with uF and is attracted by C's EPP-feature therefore remains accessible for further agreement relations and can undergo further A-movement to the subject or object position in the matrix clause. I assume that the presence of an uninterpretable feature uF on C that corresponds to, and can enter an agreement relation with, a feature of a DP is a uniform property of all finite CPs that are selected by Hyperraising or Hyper-ECM verbs in languages which allow long A-movement.

The assumption that C bears an uninterpretable feature which acts as a probe and can agree with the lexical DP inside the ‚big’ subject DP can be motivated on both empirical and theoretical grounds. According to Chomsky (2005), the phase heads C and v are, in fact, the source of all syntactic computations, and the features that drive them are exclusively associated with these phase heads. Features which are seemingly associated with non-phase heads are only derivative from the phase heads that select them. As was noted above, Chomsky (2005) argues that the ϕ -features and the T-feature of T are *inherently* features of the phase head C, but are *transferred* to and then realised on T in most languages for independent reasons (cf. Richards (2007), who provides a minimalist motivation for this transfer operation). It would therefore not be surprising to find languages where under certain circumstances, a grammatical feature of the phase head C is *not* transferred to the T head, but remains on C. In this case, the phase head would be directly involved in the grammatical operation Agree.

There is empirical evidence from numerous languages that provide support for this view. It is well-known that many languages exhibit agreement phenomena which involve complementisers and elements in the left periphery. One particularly striking example is found in Central Bantu languages such as Kiruúndi. In Kiruúndi main clauses, subjects

agree with their verbs, but in relative clauses, the verb agrees with the extracted relative operator, not with the subject:

- (15) a. abana ba-á-somye ibitabo
 children 3PL-PAST-read.PERF 8books
 'Children read books.'
- b. ibitabo bi-á-somye abana
 8books 8AGR-PAST-read.PERF children
 ‚the books that the children read’

(Kiruúndi; Henderson 2006a: 281)

Henderson (2006a, 2006b) analyses the agreement phenomenon in (15b) by suggesting that the C-position in Kiruúndi hosts uninterpretable ϕ -features which act as a probe. Henderson suggests that these features are valued by the interpretable ϕ -features of the subject in (15a), and by those of the relative operator in [Spec, C] in (15b). Moreover, Henderson argues that, as a consequence of agreement with C, the subject DP in (15a) has also moved to [Spec, C].

Complementiser agreement due to an Agree relation between uninterpretable ϕ -features on C and the ϕ -features of the subject has also been attested in non-Bantu languages like West Flemish (Bennis and Haegeman 1984; Haegeman, 1990, 1992; Shlonsky, 1994; Carstens, 2003), Bavarian (Bayer, 1984; Weiß, 2002) and Frisian (de Haan and Weerman, 1986, Hoekstra and Marácz, 1989):

- (16) a. da-n -k ik werk-en
 that-1SG-I I work-1SG
- b. da-t -j gie werk-t
 that-2SG-you you work-2SG
- c. da-t -j ij werk-t
 that-3SG-MASC-he he work-3SG-MASC

- d. da-t (-ze) zie werk-t
 that-3SG-FEM she she work-3SG-FEM
- e. da-t (-t) tet werk-t
 that-3SG-NEUT it it work-3SG-NEUT
- f. da-n (-me) wunder werk-en
 that-1PL-we we work-1PL
- g. da-t -j gunder werk-t
 that-2PL-you-PL you-PL work-2PL
- h. da-n (-ze) zunder werk-en
 that-3PL -they they work-3PL

(West Flemish; Shlonsky, 1994: 354)

- (17) a. ob-st *pro* noch Minga kumm-st
 whether-2SG PRO to Munich come-2SG
 „...whether you come to Munich.’
- b. ob-ts *pro* noch Minga kumm-ts
 whether-2PL PRO to Munich come-2PL
 „...whether you (pl) come to Munich.’

(Bavarian; Bayer 1984: 240)

- (18) da-st (do) jÛn kom-st
 that-2SG you tonight come-2SG
 „That you come tonight.’

(Frisian; Zwart, 1993: 256)

(16) shows that West Flemish has a complete paradigm of complementiser agreement for all persons and numbers, both a clitic and a full subject can co-occur with complementiser agreement, and the form of the complementiser agreement is similar to the appropriate verbal agreement ending. (17) and (18) show that in Bavarian and Frisian, the morphology of complementiser agreement is also the same as the respective verbal

agreement suffixes. Unlike West Flemish, however, complementiser agreement is restricted to 2nd person/number sets, and the presence of agreement in C triggers referential pro-drop (cf. Fuß, 2004: 3).

Various analyses have been proposed for structures like (16)-(18). While Hoekstra and Marác (1989) argue that complementiser agreement results from moving T to C and Zwart (1993, 1997) proposes that it is a morphological manifestation of movement of the AgrS-head to C, Shlonsky (1994) suggests that complementiser agreement is a reflex of Spec-head agreement in the left clausal periphery. Fuß (2004) analyses the kind of agreement shown in (15)-(18) as a product of the post-syntactic insertion of an agreement morpheme in the morphological structure. Carstens' (2003) analysis is based on the probe/goal mechanism developed in Chomsky (2000, 2001). According to her analysis, prior to the movement of the subject DP to [Spec, T], the uninterpretable ϕ -features of T act as a probe and agree with the subject DP's interpretable features. They value and mark for deletion the case feature of the subject while it is still in its base position in [Spec, vP]. After having moved to [Spec, T], the subject again agrees with the C-head and values its uninterpretable ϕ -features. Carstens (2003: 397) suggests that this Agree-relation may subsequently be followed by the movement of the ‚agreed-with' subject DP to [Spec, C].

Agreement features are not the only type of formal feature that has been argued to be found on the C-head. Another type of grammatical feature that has been argued to be associated with C and that can enter an agreement relation with a DP is the uninterpretable tense feature (uT) discussed in Pesetsky and Torrego (2001, 2004). Pesetsky and Torrego argue that the C-position in a language such as English is lexically specified as having an uT-feature, and they suggest that this feature can be checked and deleted when it enters an agreement relation with another T-feature. For example, C can agree with the interpretable T-feature of the T-head of TP, and may subsequently attract T, which gives rise to T-to-C movement. Importantly, Pesetsky and Torrego (2001) analyse the complementiser *that* in English not as a lexical C-element, but as a T-element

which moves to C. Therefore, their representation of the embedded clause in (19a) is (19b):

- (19) a. Mary thinks that Sue bought the book.
b. $[_{CP} [_T \textit{that}] + [C, \bar{u}T]] [_{TP} \textit{Sue} \textit{that} \textit{bought the book}]]$

In (19a), the uT-feature of C agrees with and attracts T (the complementiser *that*), which then moves to C. As a result, uT on C is deleted.

Another crucial aspect of Pesetsky and Torrego's proposal is the idea that (i) uT of C can also agree with another uT, i.e., with another *uninterpretable* T-feature, and that (ii) the structural case feature of DPs is an instance of a uT-feature on D. Importantly, according to Pesetsky and Torrego's (2001, 2004) theory, this means that uT on C can agree with and be deleted by the case feature of a DP. If C also has an EPP-feature, then it will attract this DP to move to [Spec, C]. Consequently, the embedded clause in (20a), which lacks a complementiser, is given the structural representations in (20b) (cf. Pesetsky and Torrego 2001: 374):

- (20) a. Mary thinks Sue bought the book.
b. $[_{CP} [\textit{Sue}, \bar{u}T]] [C, \bar{u}T] [_{TP} \textit{Sue} \textit{bought the book}]]$

In (20), the uT-feature of C agrees with uT (= structural case) of the subject DP. The EPP-feature of C attracts the subject, and both uT-features (the probe on C, and case) are subsequently deleted.

Notice that according to Pesetsky and Torrego, the case feature of the subject DP in (20b) is *valued* as nominative by T. This follows from the standard assumption that only finite T with a full set of ϕ -features can “assign” nominative case. However, Pesetsky and Torrego (2001, 2004) assume that the *deletion* of case (= uT-feature of DP) only happens when the phase (CP) is completed. This explains why the subject DP in (20b) can be attracted by and move to [Spec, C], although its case feature has already been valued by

T. Importantly, Pesetsky and Torrego's idea that case is uT on D therefore implies that a DP whose case feature has not been deleted because it has not been valued by a case assigner can also agree with and be attracted by uT on C.³⁸ I will return to this point in section 6.4, where I combine Pesetsky and Torrego's claims with the ‚big’ DP-analysis of resumption motivated in the previous chapter.

In sum, my claim that the head of a finite CP in languages which allow long A-movement bears an uninterpretable feature uF gains support from the fact that inflectional features such as tense and agreement are inherently associated with, and sometimes overtly realised on, the phase head of CP. In the next subsection, I discuss the nature of this feature uF in more detail.

6.3.2 The operation Agree and the nature of uF

The analysis outlined in section 6.3.2 is based on the idea that in long A-movement constructions, not only T, but also C, bears (an) uninterpretable uF-feature(s) that can enter Agree-relations with and attract DP_{COMPL}, which is merged as the complement of a resumptive pronoun inside the complex ‚big’ subject DP. It is because of this feature that movement of DP_{COMPL} to [Spec, C] is A-movement, obviating the otherwise resulting improper movement configuration. But what sort of feature is uF?

A first possibility is that uF is (part of) the set of ϕ -features, i.e. it is a person, gender, or number feature. As discussed, these features are inherently properties of the phase head C, but ordinarily transferred to the T-head, and I showed in section 6.3.1 that complementiser agreement phenomena are indeed attested in some of the world’s languages. One could therefore assume that Raising- and ECM-verbs in languages with long A-movement select CPs whose heads do not trigger a complete transfer of their ϕ -

³⁸ Although I believe that this conclusion follows from Pesetsky and Torrego's (2001, 2004) analysis, it is not explicitly considered by these authors. In Pesetsky and Torrego's approach, uT on C is, in fact, always checked and deleted by a *valued* case feature, but I am not certain if they consider the valuation of case a prerequisite for the uT of a DP to check uT on C. While Pesetsky and Torrego (2001) assume that uT on DP corresponds specifically to nominative case (which suggests that a particular case valuation is relevant), Pesetsky and Torrego (2004) extend the analysis of uT as case to accusative case, which means that uT corresponds to structural case in general. Given this latter view, the uT-feature that agrees with uT on C is an undeleted case feature, no matter whether this feature already has a specific value and is “marked for deletion”, or it has not been valued at all.

features. According to this view, the φ -features of C in these languages do not constitute an indivisible set, but can individually either be transferred to T or remain on C. Now recall from the discussion in chapter 5 that in long A-movement constructions, there is always a DP in the embedded subject position which receives nominative case, namely the ‚big‘ DP (the projection of the resumptive pronoun). If one adopts the standard assumption that nominative case is assigned by T, and if one follows Chomsky (2000, 2001) in assuming that the crucial feature required for case valuation is the person feature, then the person feature must be among those features that are transferred to T in this scenario. This leaves gender and number as possible candidates of features which “survive” on C.

Another version of this idea would be the following. Suppose that the transfer of features from C to T is a two-step process. First, the features of C are *copied* onto T, and in a second step, the duplicate features on C are *deleted*. In this view, the set of φ -features is always completely transferred from C to T, but it may be that the deletion process on C is deficient, in which case some, or all, uninterpretable φ -features will survive on C. If a partial copying process is something that can be “triggered” by a Raising or ECM-verb, then we would expect that these verbs can appear with clausal complements whose C-heads also have uninterpretable φ -features.

In light of these theoretical considerations, it makes sense to investigate the hypothesis that uF on C is in fact $u\varphi$, and consider its implications. If the φ -features of DP_{COMPL} in a long-A movement construction do indeed enter an agreement relation with $u\varphi$ -features on C, then the existence of complementiser-agreement phenomena of the sort discussed in the preceding section leads one to expect that we find at least some languages in which Hyperraising, Copy Raising or Hyper-ECM is accompanied by visible φ -feature agreement between an embedded lexical subject and a complementiser.

Unfortunately, this is not what I found. Not one of the languages with long A-movement that were discussed in chapters 2 and 3 manifests overt complementiser agreement with the φ -features of a raised subject DP. Although not every instance of the syntactic

operation Agree is necessarily overtly realised by agreement morphology in a language, the absence of any “visible” morphological sign of agreement between embedded C and the A-moved subject DP in the languages that I examined casts doubt on the idea that it is ϕ -feature agreement between C and the subject-DP_{COMPL} that enables the latter to escape the CP.

Another problem with the idea that uF on C is φ is raised by the fact that in some of the languages examined in chapters 2 and 3, complementisers are based on a form of the verb “say”. This is the case, for example, in Zulu (which allows Hyperraising with the verb *fanele*), and Yoruba (which allows Copy Raising with the verb *jo*):

- (21) Amadoda a-fanele [ukuthi a-hamb-e manje]
 man6 SM6-ought that SM6-leave-SUBJ now
 „The men ought to leave now.’

(Zulu; Zeller 2006b:1)

- (22) Olú àti Adé jò [pé wón ní owó lṵwṵ]
 Olu and Ade resemble that they have money in hand
 „Olu and Ade seem to be rich.’

(Yoruba; Adesola, 2005:110-112)

According to Boeckx (2003: 88), verbal complementisers lack ϕ -features and never trigger agreement. Following Finer (1997:709), Boeckx considers verbal complementisers as part of a compound/serial verb construction with the embedded verb. Boeckx assumes that the second verb fails to show agreement, as is typical of serial verb constructions, which means that verbal complementisers never have ϕ -features.

It follows from these considerations that the hypothesis that the syntactic relation between C and DP_{COMPL} in long A-movement constructions is ϕ -feature agreement is probably incorrect. Although it is consistent with the theoretical proposal outlined above,

and although it is not directly contradicted by the data, I reject this hypothesis, due to the lack of empirical support.

An alternative hypothesis regarding uF that follows from the discussion in section 6.3.1 is to treat the feature uF of C as the equivalent of Pesetsky & Torrego's (2001, 2004) uT-feature. As discussed above, Pesetsky and Torrego argue that C might bear an uninterpretable tense feature uT, and that this feature can enter an agreement relation with the structural case feature of a DP, which is analysed as an instance of uT on D. Adopting this proposal, it could be suggested that Raising and ECM-verbs in languages with long A-movement might select a CP whose head has uT. This feature then enters an Agree-relation with the unvalued case feature of the DP-complement of the head of the ‚big’ subject DP, and C's EPP-feature attracts the DP_{COMPL} to [Spec, C]. Since C bears only an uT-feature, but no ϕ -features, the Agree-relation between C and the DP cannot value the case feature of the subject DP. Consequently, the complement DP must enter a further Agree-relation with an element in the matrix clause.

This proposal works technically, but one wonders if it can also be supported by empirical evidence. However, it is not even clear what the empirical predictions would be. Since uT on C is uninterpretable, we do not expect it to have any semantic effects, but it is also not clear that syntactic agreement between two uT-features would have any morphophonological effects. But if there is never any measurable effect of the postulated Agree-relation between uT on C and uT on DP_{COMPL}, then the postulation of uT on C is nothing more than a technical implementation of the earlier conclusion that long A-movement requires a C head with an uninterpretable grammatical feature.

Fortunately, however, there is interesting indirect evidence from some languages that supports the idea that long A-movement is linked to the presence of an uT-feature on C. This evidence is based on Pesetsky and Torrego's (2001, 2004) analysis of the so-called *that-t* effect, which is based on their theory of case as a uT-feature. Consider the contrast in (23b) (Pesetsky and Torrego 2001: 371):

- (23) a. Who did John say will buy the book?
 b. *Who did John say that will buy the book?

The example in (23) illustrates that subject extraction across a complementiser is not possible in English. (23b) is hence a typical instance of the *that-t*-effect. The ungrammaticality of (23b) follows from the standard analysis of successive-cyclic wh-movement sketched in section 6.1 in combination with the specific assumptions made by Pesetsky and Torrego. In order for the subject wh-phrase to be able to move from the embedded clause to the matrix [Spec, C]-position, it needs to move first to the embedded [Spec, C]. As discussed above, Pesetsky and Torrego assume that this movement operation is a reflex of an agreement relation between uT on C and uT on the subject DP. In this process, uT on C is deleted. Now recall that Pesetsky and Torrego (2001) analyse the complementiser *that* as a T-element that has to enter an agreement relation with uT on C in order to move to and be overtly realised in C. This means, however, that a subject DP in [Spec, C] is incompatible with a complementiser, since both elements check uT on C. Consequently, long subject extraction, which needs to proceed via the embedded [Spec, C], is only possible if the complementiser *that* is absent.

This analysis opens the possibility of finding empirical evidence for the claim that long A-movement is allowed in languages with uT on C by examining the interaction of long A-movement and complementisers. Suppose that there is a language which allows Hyperraising, but which also has a complementiser like English *that*, i.e. a T-element that moves to C. If Hyperraising is possible because of uT on C, but if uT on C can be checked and deleted by T-to-C movement of this complementiser, then we expect that in these languages, Hyperraising is possible only *in the absence of a complementiser*. Interestingly, Rumanian, Bhojpuri and Chamorro are languages which behave as predicted. Example (13b) and (14) of chapter 2 are repeated below as (24):

- (24) a. Toti băieții s-au nimerit [să fie bolnavi]
 all the boys REFL.have.PRES.3PL happened SUBJ PRT be sick
 ‚All the boys happened to be sick.‘

- b. *Toți băieții s-au nimerit [ca să fie bolnavi]
 all the boys REFL.have.PRES.3PL happened SUBJ SUBJ PRT be sick
 ‚All the boys happened to be sick.‘

(Rumanian; Grosu and Horvath, 1984: 351)

As noted by Grosu and Horvath (1984), movement of the embedded subject DP out of the finite complement clause in (24a) is rendered ungrammatical if the complement clause is introduced by an overt complementiser. A similar contrast is observed in Bhojpuri by Shukla (1981). Example (43) of chapter 2 is repeated below as (25):

- (25) a. i: la:g-a:la [ki Lalit Hindi: ja:na-a:la:]
 it seem-3SG-MASC-PRES COMP Lalit Hindi know-3SG-MASC-PRES
 ‚It seems that Lalit knows Hindi.‘

- b. Lalit la:g-a:la [Hindi: ja:na-a:la]
 Lalit seem-3SG-MASC-PRES Hindi 3SG-MASC-PRES
 ‚Lalit seems to know Hindi‘

(Bhojpuri; Shukla, 1981: 252-253)

Shukla (1981: 259) states that Hyperraising of the embedded subject shown in (25b) requires the ‚deletion‘ of the complementiser *ki* ‚that‘ which is present in the non-Raising expletive variant in (25a). In other words, the embedded subject DP cannot enter an Agree-relation with the matrix T if the embedded CP includes an overt complementiser.

Another language in which long A-movement takes place only in the absence of an overt complementiser is Chamorro. The Hyper-ECM example (29) of chapter 3 is repeated here as (26):

- (26) a. Si Lucy ha ekspekta [na si Miguel pära u
 the Lucy 3SG expect COMP the Miguel IRREAL 3SG
 konni' i famagu'un pära eskuela]
 take the children to school
 ‚Lucy expects that Miguel will take the children to school.‘
- b. Si Lucy ha ekspekta si Miguel [pära
 the Lucy 3SG expect the Miguel IRREAL
 u konni' i famagu'un pära eskuela]
 3SG take the children to school
 ‚Lucy expects Miguel to take the children to school.‘

(Chamorro; Gibson, 1992: 101; Davies and Dubinsky, 2004: 57)

The omission of the complementiser in the Hyper-ECM construction in (25b) suggests that the complementiser is not allowed.

I assume that in the Hyperraising constructions in (24a), (25b) and (26b), uT on the C-head probes and agrees with DP_{COMPL} (the complement of resumptive pro inside the ‚big‘ DP). DP_{COMPL} is then attracted by C's EPP-feature and moves to [Spec, C]. Since it still has an unvalued case feature, it remains accessible for further Agree-operations; it agrees with the ϕ -features of matrix T or v and is eventually attracted by the EPP-feature to move to the matrix [Spec, T] position/object position. In constructions such as (24b), however, the uT-feature of C is valued, and subsequently deleted, by the complementiser *ca*, which has moved from T to C. Consequently, DP_{COMPL} in (24b) cannot be moved out of the CP. As a consequence, (24b) is what could be considered a *that*-t-effect in long A-movement constructions. The existence of such effects is predicted by the theory developed here, according to which long A-movement involves an Agree-relation between an uT-feature of C and the uT-feature of an embedded DP_{COMPL}. In languages which spell out T-heads as complementisers, these complementisers check and delete the uT-feature of C and thereby prevent C from entering this Agree-relation with DP_{COMPL}. The impossibility of long A-movement in the presence of a complementiser therefore

provides evidence that this grammatical operation is triggered by an uF-feature of C, and the data in (24)-(26) support the view that this feature is uT in Rumanian, Bhojpuri and Chamorro.

Note that this analysis does not predict that complementisers and long A-movement are generally incompatible. In languages with Hyperraising, Hyper-ECM or Copy Raising constructions where complementisers are allowed inside the complement clauses, these complementisers are not T-elements, but “ordinary” realisations of the C-position. In the same way that not all languages exhibit *that*-t-effects in A-bar movement contexts, not all languages exhibit these effects in long A-movement constructions.

The uT-feature may not be the only type of feature that Raising or ECM verbs select as part of the C-heads of their complements. Another piece of evidence that suggests that there is an Agree-relation between complementisers and embedded DPs in Hyperraising and Hyper-ECM constructions comes from the appearance of a focus particle in Kikuyu Hyperraising constructions (see Perez, 1985). Example (22) from chapter 2 is repeated here as (27):

(27) a. Kũ-ũĩkáine [atĩ mũ-ndũ-mũ-rũme ũ-yũ óórág-íré mũ-ndũ]
 SM17-has been known that PERS1-man1 this1 SM1-kill-PAST PERS1
 ‚It is known that this man killed a person.’

b. Mũ-ndũ-mũ-rũme ũ-yũ ní óóíkáine
 PERS1-man1 this-1 FOC SM1-has been known
 [atĩ nĩ óórág-íre mũ-ndũ]
 that FOC SM1-kill-PAST PERS1
 ‚This man is known to have killed a person.’

(Kikuyu; Perez, 1985: 2-4)

In the expletive variant in (27a), there is no focus particle associated with the complementiser *atĩ* ‚that’. However in (27b), the focus particle *nĩ* follows both the complementiser *atĩ*- and the raised subject DP *mũndũmũrũme ũyũ* ‚this man’. I suggest

that the occurrence of this focus particle is the expression of an Agree-relation that has been established between the raised DP_{COMPL} and the complementiser of the embedded clause from which Hyperraising has taken place. I assume that in the Hyperraising construction in (27b), there is a feature $uFOC$ on the C-head that probes and agrees with DP_{COMPL} . DP_{COMPL} is then attracted by C's EPP-feature and moves to [Spec, C]. Since it still has an unvalued case feature, it remains accessible for further Agree-operations; it then agrees with the ϕ -features of matrix T and is eventually attracted by the EPP-feature to move to the matrix [Spec, T]-position. In (27a), however, the embedded C lacks the $uFOC$ -feature and the corresponding focus particle. As a result, DP_{COMPL} cannot agree with C; it cannot raise out of the CP but rather remains in the embedded [Spec, T]-position.

As noted above, I have not been able to find languages with long A-movement which show ϕ -feature agreement between the raised subject DP and the embedded complementiser. However, the Kikuyu data show that at least some languages exhibit signs of overt agreement between C and DP_{COMPL} . Furthermore, the existence of languages with *that*-t-effects in Hyper-ECM or Hyperraising constructions follows from the idea that in these languages, long A-movement is contingent on an Agree-relation between the uT -features of C and DP_{COMPL} . One could of course generalise these findings and assume that in *all* languages with long A-movement, the respective Raising and ECM-verbs select CPs whose heads have either uT or $uFOC$. The overt manifestation of these features is then attested only in languages with overt focus markers or with complementisers of category T. However, I want to consider one other possibility regarding the feature specification of C-heads that license long A-movement to their specifiers, which may be realised in some of the languages under investigation.

Recall that the feature uF on C must be able to enter an Agree-relation with a corresponding feature on the subject DP. So far, I have considered ϕ -features (which are interpretable on DP), tense features (which are equivalent to case and hence uninterpretable on DP) and focus features (which are interpretable on DP). A final possibility that I want to consider now is that the feature which acts as a goal for the

probe uF on C is DPs *categoryal feature* D. The corresponding feature of C which acts as the relevant probe would then be an uninterpretable and unvalued categoryal feature uCAT, which is valued by the D-feature of the DP. If this feature on C agrees with the D-feature of a subject DP, it inherits the value D from DP and is subsequently deleted.

I therefore propose that complementisers in some languages can have an uninterpretable categoryal feature with an unspecified value. An agreement relation with a particular syntactic category can value this feature, and it would subsequently be deleted. In this respect, the uCAT-feature is comparable to the uninterpretable ϕ -features of T, which are valued by the interpretable ϕ -feature of the DP T agrees with, and then deleted before the derivation is interpreted by the conceptual-intentional interface. Importantly, however, the valued uninterpretable ϕ -features of T have an effect at the PF-interface; they are interpreted as agreement morphology on a verb or auxiliary. The question is, can a valued uninterpretable uCAT-feature of C also have any observable morphological effect?

I suggest that a C-head whose uCAT-feature has been valued by D may in some languages be interpreted at PF as a *subjunctive*. As was discussed in chapters 2-4, many languages which allow Hyperraising, Hyper-ECM or Copy Raising do so out of subjunctive CP-complements. Examples (1), (7), (8), (13) and (15) of chapter 2 are repeated here as (28), (29), (30), (31) and (32):

- (28) i kopeles fenonde [na fevgun]
the girls-NOM seem-3PL SUBJ leave
„The girls seem to be leaving.”

(Greek; Soame and Perlmutter, 1979: 156)

- (29) John-ga saikin [motto benkyoosu-ru-yooni] nat-ta
John-NOM recently more study-NONPAST-SUBJ happen-PAST
(lit.) „It recently happened as a natural result that John studied harder.”

(Japanese; Uchibori, 2001: 146)

- (30) Amadoda a-fanele [ukuthi a-hamb-e manje.]
 man6 SM6-ought that SM6-leave-SUBJ now
 „The men ought to leave now.’

(Zulu; Zeller 2006b:1)

- (31) Toti băieții s-au nimerit să fie bolnavi
 all the boys REFL.have.PRES.3PL happened SUBJ PRT be sick
 „All the boys happened to be sick.’

(Rumanian; Grosu and Horvath, 1984:351)

- (32) æli lazem æst [ke ketab-ra be hæsaen be-dæh-æd]
 Ali necessary is that book-ACC to Hassan SUBJ -give-3SG
 „Ali is required to give the book to Hassan.’

(Persian; Darzi, 1993:82)

I assume that the uCAT is an uninterpretable feature on the C-head which is valued by the interpretable categorial feature of the DP_{COMPL}. A uCAT feature on C which is valued as D (the extended projection of nouns) derives a complement clause with nominal features – i.e. subjunctives.

The idea that subjunctives are noun-like in nature is not new. According to Carlson (1992), finiteness is scalar in nature (or gradable) and there are degrees/levels of finiteness that fall along a range of relative possibilities. While the infinitive is considered to be maximally non-finite, the subjunctive is regarded to be less finite than the declarative (Palmer, 1986:162). Carlson (1992:79) also suggests that one of the properties that determine the scale of finiteness of a sentence is nominalising morphology: the more non-finite a clause is, the more likely it is to have an overt reflex of nominalising morphology.

Zeller (2006a) adopts the idea that subjunctive clauses are nominal in his analysis of Hyperraising in Zulu. He shows that Zulu subjunctives (which allow Hyperraising of their subjects, (35)) are negated like attributive adjectives, (34) (which are [+V, +N]), and not like regular indicatives, (33) (Zeller 2006a: 17):

(33) Mdu a-ka-lu-theng-i ubisi (indicative)
 Mdu1a NEG-SM1a-OM11-buy-NEG milk
 ‚Mdu is not buying milk.’

(34) uthisha o-nge-m-dala (attributive adjective)
 teacher1a RC1a-NEG-BP-old
 ‚the teacher who is not old.’

(35) Ku-fanele [ukuthi uMdu a-nga-theng-i imoto le] (subjunctive)
 LOC-ought that Mdu1a SM1a-NEG-buy-NEG car9 DEM9
 ‚Mdu should not buy this car.’

(Zulu: Zeller, 2006a: 268)

According to the hypothesis I put forward here, the ‚nounlikeness’ of subjunctive CPs is linked to a feature value that the complementiser has inherited as a result of its agreement relation with the subject DP_{COMPL}.

Obviously, the hypothesis that C can have a uCAT-feature which can be valued by a DP creates many questions. For example, one of the questions that needs to be addressed is whether the uCAT-feature can only be valued by a DP – one would expect that it could also be valued by other categories, say, TP, in which case C would adopt a verbal categorial nature. But perhaps this is not possible, and uCAT can only Agree with an “active” goal, i.e. one with unvalued case, which would leave DPs as the only possible goals for a probing uCAT. Another alternative that would yield the same result would be

to assume that uCAT is actually uD, an uninterpretable D-feature³⁹ – this would mean that only DPs can check it. But it is not clear if this still allows the derivation of the morphological effects of the subjunctive.

To summarise: I assume that the feature uF on C, which enables the embedded subject DP_{COMPL} to undergo long A-movement, may have different realisations in different languages. Although it is impossible to provide conclusive, theory-independent, evidence for the existence of the uninterpretable feature uF on C in every language, the empirical properties of some of the languages with long A-movement provide evidence that these constructions involve an Agree-relation between formal features of C and the raised DP.

In the final section of this chapter, I show how the idea of an uninterpretable feature in C (for which I continue to use the label “uF” as a cover term), together with the big-DP analysis of resumption motivated in the preceding chapter, explains the possibility of long A-movement.

6.4 The analysis of long A-movement

6.4.1 ‘Big’ DP and multiple Agree

Consider the sentence pairs in (36) and (37):

(36) a. zvi-no-it-a [sekuti Vimbai a-ka-ziya]
 SM8-PRES-seem-FV that Vimbai SM1-PRES-hungry
 ‘It seems that Vimbai is hungry.’

b. Vimbai a-no-it-a [sekuti a-ka-ziya]
 Vimbai SM1-PRES-seem-FV that SM1-PRES-hungry
 ‘Vimbai seems to be hungry.’

(Shona)

³⁹ The EPP used to be regarded as an uninterpretable D-feature in Chomsky (1995).

- (37) a. Θ eoro [pos o yanis ine eksipnos]
 Consider-1SG COMP NOM-John be-SG smart
 ‚I consider John to be smart.
- b. Θ eoro ton yani [pos ine eksipnos]
 Consider-1SG ACC-John COMP be-SG smart
 ‚I consider John to be smart.’

(Greek; Joseph 1976: 241)

The sentence in (36b) is a Hyperraising construction; (37b) exhibits Hyper-ECM. The (a)-examples show the corresponding sentences in which no long A-movement has occurred. In both constructions, the embedded tensed CP licenses nominative case assignment on the embedded subject.

Importantly, since the matrix verb is a Raising verb in (36a) and (36b), I assume that it selects a CP with an uF-feature in *both* examples. The same holds for the embedded CPs in (37a) and (37b). My approach therefore assumes that the properties of the finite clause from which Raising has occurred are basically the same as those of a finite clause with the subject *in situ*, as long as both CPs are selected by a Raising or ECM-verb. No distinction between CPs as strong or weak phases is required to explain the contrast in (36) and (37). As I will discuss below, the only difference between the CPs in the (a)- and (b)-examples is that in the latter cases, C has an EPP-feature, which attracts the lexical subject to [Spec, C].

In the (a)-examples in (36) and (37), C has uF, T has a complete set of φ -features, presumably inherited from C.⁴⁰ Both the uninterpretable features of T (φ -features) and of C (uF) can act as probes for the respective interpretable features of the subject DP in [Spec, v]. According to Hiraiwa (2001, 2005), the assumption that in syntactic

⁴⁰ I assume, following Chomsky (2005) that all features originate in the phase head C, but that the features of C are not completely transferred to T. Therefore, uF remains on C.

connections, probe-goal relationships are always one-to-one is an unnecessary stipulation. He therefore proposes that probes enter a syntactic relation with all potential goals in their C-command domain simultaneously (cf. Henderson, 2006a). Similarly, Carstens (2001, 2003) suggests that the uninterpretable ϕ -features of a T and C can initiate an Agree-relation with a subject. Since the features are split across C and T, both heads can simultaneously enter an agreement relation with one and the same goal. I assume that in (36a) and (37a), this goal is the subject DP. The uF-feature of C probes the corresponding feature of the subject DP, and the ϕ -features of T simultaneously probe the subject DP's interpretable ϕ -features. Both Agree-relations are simultaneously established at the completion of the CP-phase, and T's EPP-feature subsequently attracts the subject to [Spec, T]. The tree diagram in (38) illustrates this situation for the embedded clause in example (36a):

(38)

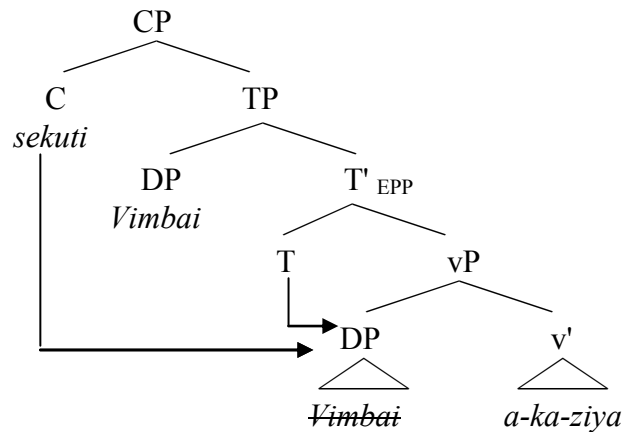

Now consider the examples with long A-movement in (36b) and (37b). The CP selected by the matrix verbs again bears uF, and T bears $u\phi$ -features, so the uninterpretable features of C are again distributed across C and T, and act as probes on both heads. However, as noted in chapter 5, languages which allow long A-movement may realise this option by generating a ‚big‘ DP inside the embedded subject position, which is theta-marked by v. The head of this DP selects the complement DP with which it shows

concordial agreement. Again, the uninterpretable ϕ -features of C and T act as probes that search for goals. Importantly, the probes in C and T do not have to choose the same goal; rather, they can also enter separate agreement relations with separate goals. In a construction such as (36b) and (37b), in which the embedded subject is a ‚big’ DP, there are now two DPs which are accessible: the big DP itself, and DP_{COMPL} . This follows from the description of closeness which is part of Chomsky’s (2000) definition of locality:

(39) *Locality* (Chomsky, 2000: 122)

$D(P)$ is the C-command domain of P, and a matching feature G is closest to P if there is no G' in $D(P)$ matching P such that G is in $D(G')$.

The crucial part of (39) is that for a goal G' to be closer to a probe P than G, G must be in the C-command domain of G' . The features that serve as a goal for the probes in C and T are associated with DP_{COMPL} and the ‚big’ DP. But crucially, the ‚big’ DP dominates and therefore does not C-command DP_{COMPL} , and obviously, DP_{COMPL} does not C-command ‚big’ DP either. Since neither the ‚big’ DP nor DP_{COMPL} C-commands the other, both count as equidistant to the higher probes and can in principle both enter agreement-relations with features of T and C respectively (see Pesetsky and Torrego (2001) for a similar interpretation of locality).⁴¹

There are now four ways in which grammar can establish Agree-relations between the probes of C and T and the features of the two DPs. A first possibility is that only the ‚big’ DP acts as a goal for both uF on C and $u\phi$ on T. As a result of the two Agree-relations, case on the big DP, uF on C and $u\phi$ on T would be valued and deleted, and the whole ‚big’ DP would move to [Spec, T]. However, this scenario would leave the DP_{COMPL} (the complement DP of the head of the ‚big’ DP) with an unvalued case feature, and the derivation would crash at the CI-interface. The same can be said about the second option,

⁴¹ If we assume instead that the features that are relevant for Agree are located on the head of the two DPs, then the head of ‚big’ DP (the resumptive pronoun) is a closer goal than the head of DP_{COMPL} , since it C-commands the DP_{COMPL} . However, DP_{COMPL} may be able to move to [Spec, D] in order to escape the C-command domain of the resumptive pronoun (see Boeckx (2003: 38-39) for the suggestion that the DP_{COMPL} moves out of the ‚big’ DP through the [Spec, D] position in a successive cyclic manner). So in principle, both goals can become accessible to either probe.

where both probes would choose the embedded lexical DP as its goal, which would leave the ‚big’ DP without case. This means that the derivation will crash if it includes a ‚big’ DP and uF and u ϕ both locate features of the same DP as their goal. It follows that with a ‚big’ DP, one of the two probes will always use the big DP as a goal, and the other the embedded complement DP.⁴²

Having ruled out the first two options, in which only one of the two available goal DPs enters an Agree-relation with both probes, let me turn to the remaining alternatives. Here, the two probes in C and T select different goals. Assume that the uninterpretable ϕ -features of T select the corresponding features of the big-DP as a goal, while the uF-feature of C agrees with the embedded complement DP:

(40)

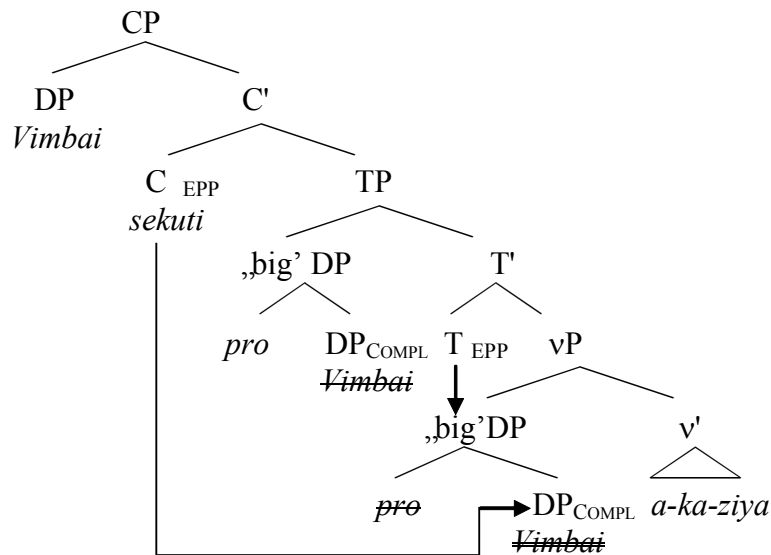

As illustrated in (40), when a complex resumptive ‚big’ DP is created, the ‚big’ DP itself may be probed by and receive case from T. T’s EPP-feature then triggers movement of the complex DP to [Spec, T]. Importantly, the DP embedded in the ‚big’ DP is simultaneously probed by C. However, although the respective feature of the complement

⁴² This is possibly due to a general tendency of grammar to avoid instances of multiple Agree whenever possible. In other words, for as long as there are active DPs, every newly merged probe chooses a different goal, in order to avoid a crash of the derivation. Only when the number of accessible goals is smaller than the number of probes will some probes share a goal, as in the derivation shown in (38).

DP now agrees with and deletes uF on C, uF (whatever its nature) is not sufficient to value case of the DP, and the lexical DP remains active.

However, recall that the phase head C can be equipped with an edge-feature, which in (40) should be called an EPP-feature, due to the Agree-relation between uF and the relevant feature on DP. I therefore assume that in (40), C has an EPP-feature, which now attracts the goal-DP. This means that when uF agrees with DP_{COMPL}, C also attracts it and moves it to [Spec, C]. Therefore, the lexical DP escapes the effects of the PIC; it remains accessible for further computations outside the phase and can enter further Agree-relations with probes in the matrix clause to value its case feature. Furthermore, as discussed in the preceding sections, movement which is triggered by an EPP-feature (i.e. an edge-feature associated with a head which enters an agreement relation), counts as A-movement. Therefore, the moved subject DP can also undergo further movement to another A-position in the matrix clause. The complete derivation of the Hyperraising construction in (36b) therefore looks like (41):⁴³

⁴³ I assume that the agreement relation with the complement DP and C is established when the big DP is still in its base position in [Spec, v]. I further assume that the lexical DP therefore also moves directly from this position to [Spec, C]. At the same time, the big DP is attracted by the EPP-feature of T and moves to [Spec, T], pied-piping the copy of the lexical DP. The structure in (40) is therefore equivalent to one in which the big DP would have moved to [Spec, T] first, followed by movement of the complement DP. However, recall that all Agree- and movement operations happen simultaneously within the phase.

(41)

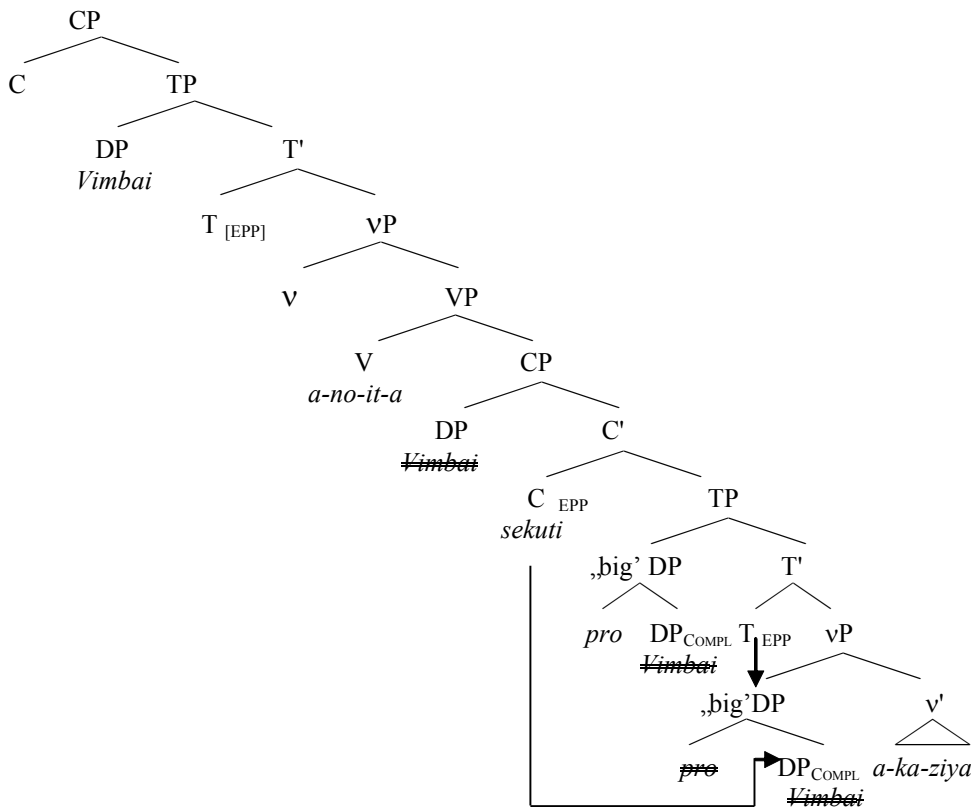

As (41) shows, the embedded clause includes a ‚big’ DP whose head is a resumptive pronoun (*pro*). While the ‚big’ DP enters an agreement relation with the embedded T and receives nominative case inside the embedded clause, the complement of the resumptive pronoun first enters an Agree-relation with uF on C and undergoes A-movement to the edge of the phase. From there, DP_{COMPL} acts as a goal for the probing u ϕ -features of the matrix T, whose EPP-feature then attracts it to matrix [Spec, T].

There is still a fourth option, namely the reverse situation from the one just described. Instead of the u ϕ on T probing the ‚big’ DP, these features could also find the interpretable ϕ -features of the complement DP as their goal, and at the same time, the uF-feature of C probes and attracts the ‚big’ DP. In this case, it would be the lexical DP that enters an agreement relation with T and moves to [Spec, T], while the whole big DP would be attracted by the EPP-feature of C:

(42)

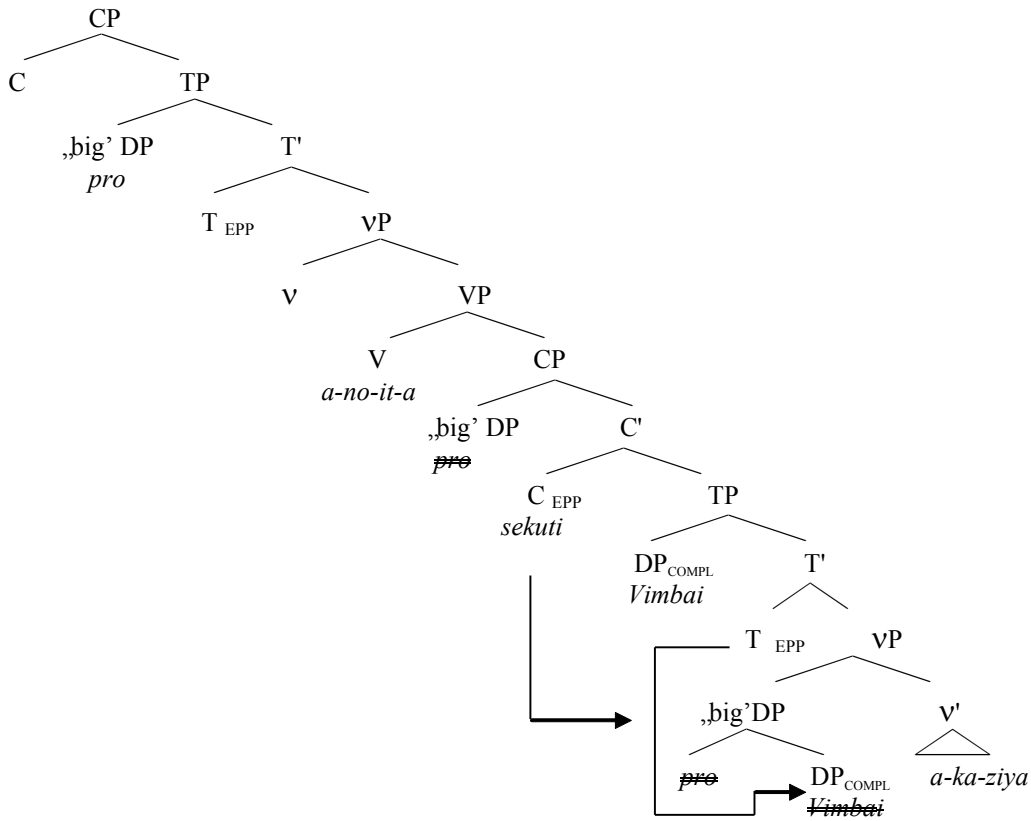

According to the derivation in (42), the ‚big’ DP has undergone remnant movement to [Spec, C]. Its head is again pronounced as a pronoun, while the complement of this pronoun has moved to the embedded [Spec, T]. The remnant ‚big’ DP (the pronoun) would now agree with the matrix T or v and raise into the matrix clause, while the DP_{COMPL} would receive nominative case in the embedded clause. In other words, (42) would give rise to a Hyperraising or Hyper-ECM construction with a raised pronoun and a stranded resumptive complement DP. However, to the best of my knowledge, such constructions are never licensed in any of the languages discussed in chapters 2 and 3. Examples such as (43) and (44) below are not possible:

- (43) *Wón jo pé Olú àti Adé ní owó lọwọ
 they resemble that Olu and Ade have money in hand
 *‚They seem that Olu and Ade are rich.’

(Yoruba)

- (44) **iyē a-no-it-a [sekuti Vimbai a-ka-ziya]*
 she SM1-PRES-seem-FV that Vimbai SM1-PRES-hungry
 *‘She seems that Vimbai is hungry.’

(Shona)

The question is, why are such constructions never produced by the grammar of the languages which otherwise allow long A-movement?

I believe that the relevant examples in (43)-(44) are ruled out by Condition C of Binding theory (cf. Chomsky 1981). Recall from chapter 5 that the ‘big’ DP analysis is based on the assumption that the big DP and DP_{COMPL} are co-referential, since they share the same theta-role. In a grammatical construction such as (41), the complement DP ends up in the matrix clause, stranding the resumptive pronoun in the embedded clause. In terms of the binding theory, the pronoun and its antecedent are therefore in different local domains, and their coreferential interpretation does not create a problem for Condition B (which requires pronouns to be free only in their local domain). In (43)-(44), however, it is the pronominal ‘big’ DP that ends up in an A-position in the matrix clause. From this position, it c-commands the stranded lexical DP. However, since the stranded complement DP is a referential expression, it is subject to Condition C of the Binding Theory, which states that a referential expression must not be bound. Clearly, this condition is now violated if the raised pronoun (the remnant ‘big’ DP) is coreferential with the stranded DP. However, this coreference is a consequence of the ‘big’ DP-analysis of resumption. This means that constructions such as (43) and (44) with stranded lexical DPs can never converge; long A-movement is only possible if the ‘full’ lexical DP_{COMPL} is raised, stranding the resumptive pronoun.⁴⁴

⁴⁴ This explanation implies that the option of stranding the DP_{COMPL} is ruled out only if the complement DP is a referential expression. In contrast, if DP_{COMPL} is also a pronoun, the derivation illustrated in (41) is permitted, since there is no condition C violation. This means that a construction with a raised pronoun which leaves behind a resumptive pronoun has two possible underlying representations: it is possible that the ‘big’ DP is in [Spec, TP] while the DP_{COMPL} has raised, but it could also be the case that the resumptive pronoun is the DP_{COMPL} which has been stranded in the embedded [Spec, TP] while the remnant ‘big DP’ has raised. As far as I can see, there is no way to tell these two derivations apart.

To conclude, the only available option for a finite clause with a ‚big‘ DP subject to converge is that T probes the ‚big‘ DP, while C probes the complement of the resumptive pronoun. In addition, this structure requires C to have an edge-feature (EPP), in order for the lexical DP to be able to escape the CP-phase via [Spec, C]. In the final subsection of this chapter, I briefly discuss the EPP-feature on C.

6.4.2 A note on the EPP- and edge-features

I have suggested that in the “winning” derivation in (41), the head of the finite CP from which long A-movement takes place is equipped with an EPP-feature that licenses movement of the subject. In contrast, in examples such as (36a) and (37a), in which no long A-movement has occurred, the C-head lacks the EPP-property, and no movement to [Spec, C] takes place. However, given that the C-head agrees with the subject DP in both examples, the question arises why the EPP-feature only appears in the former case.

My answer to this question is based on the idea that EPP- or edge-features of phase heads are optional in general, but can be freely inserted in exactly those cases where grammar requires movement in order to guarantee that the derivation converges.⁴⁵ As the discussion in section 6.2 has shown, this idea is applied in the case of the insertion of intermediate edge-features in long A-bar movement constructions. If an embedded clause includes a wh-phrase, which needs to undergo A-bar movement into the main clause, then the C-head needs to be equipped with an edge-feature that allows the wh-phrase to escape the CP. Without the edge-feature, the wh-phrase would not undergo movement, and the derivation would crash (or converge with a deviant interpretation).

The same considerations apply to the edge-feature of v. In discussing movement to the edge of vP in languages such as Icelandic and English, Chomsky (2001:34-36) suggests that the optional edge-feature of a phase head is licensed when it has ‚an effect on the output‘. Chomsky’s example is the presence of an EPP-feature on the phase head v, which is present in English in exactly those contexts where the direct object DP is a wh-

⁴⁵ See, for example, Chomsky (2000), who argues that the EPP-feature of T is universal, while the edge-features of C and v are optional.

phrase and must escape the vP in order to be able to move to [Spec, C] to take scope. While the latter movement step is triggered by the edge-feature of C, the wh-phrase can only be attracted by C if it is in the edge of vP (because of the PIC). Grammar then licenses the edge-feature on v which enables the wh-phrase to move to [Spec, v], in order to become accessible for the edge-feature of the next phase head. In contrast, languages such as Icelandic, which have object shift, allow for the EPP/edge-feature of v to appear in other contexts as well. In Icelandic, object shift is impossible when v has not raised to T (a phenomenon known as Holmberg's Generalisation (HG) (Holmberg 1986)). Consider the Icelandic examples in (45):

- (45) a. Hann las þær ekki (*þær)
 he read them not
 'He didn't read them.'

(Icelandic; Diesing, 1996: 67)

- b. *Hann hefur bókina_i [_{vP} lesið t_i]
 he has book.the read
 'He has read the book.'

(Icelandic; Bobaljik, 2002: 208)

In (45a), it is assumed that the verb in v has raised to T and that the object has also shifted to the edge of the vP, thereby yielding a grammatical sentence. In contrast, in (45b), v has not raised. Therefore, movement of the direct object DP *bókina* 'book' to the edge of the vP results in an ungrammatical sentence. Chomsky (2001:35-36) argues that in examples such as (45b), where v has not raised and object shift cannot take place, v is not required to have an EPP feature. In contrast, in (45a), where v has raised, creating the right environment for object shift, v is assigned an EPP feature in order to attract the object to the edge of the vP where it can be given a new interpretation. In other words, the EPP feature is licensed when its occurrence forces movement which has an effect on the output which here means that the object receives a particular interpretation.

Müller (2004) also discusses the possibility that grammar provides certain heads with features that trigger movement in those contexts where independent requirements make movement of a particular constituent necessary. Müller (2004) analyses verb second phenomena in Germanic languages in terms of vP-(v*P)-fronting. In his theory, the fronted vP may only include one phrase in its edge and the finite verb in v or V. This condition implies that all other material vacates the vP before the vP moves. Müller (2004: 187) therefore considers the possibility that the features of higher functional heads which trigger the necessary evacuation movement are licensed if and only if there is also vP movement to [Spec, C], i.e. ‚only if this operation has an indirect effect on outcome’.

Zeller (2006c) also proposes that EPP-features can be associated with functional heads in order to trigger movement operations that are required for convergence. In his analysis of Kinyarwanda ditransitive locative constructions, Zeller suggests that the locative DP in these constructions is generated as the complement of a preposition. However, when the preposition incorporates into the verb as an applicative marker (cf. Baker 1988), the locative DP is left without case (since incorporated lexical heads cannot assign case). The only potential case assigner is v. However, Zeller shows that the necessary Agree-relation between v and the locative DP *in situ* is blocked by the intervening Theme DP in [Spec, V] – unless the locative DP moves to a second specifier of VP on top of the theme. For this movement to be licensed, V needs to be equipped with an EPP-feature. Crucially, in Zeller’s analysis, this feature is not related to an Agree-relation between the moved DP and the attracting head V. Rather, the EPP is associated with V only to trigger a movement operation that allows the locative DP to end up in a position from where it is accessible to a higher probe and can get its case feature valued.

Based on these considerations about the availability of EPP/edge-features, I assume that an EPP-feature can be associated with C bearing an uF-feature if the respective A-movement step ‚has an effect on the outcome’, i.e. if it is a last resort operation to produce a convergent derivation. This is the case if an embedded finite CP includes a ‚big’ DP. As was shown above, such a construction can only converge if the embedded DP can leave the CP in order to establish an Agree-relation with T or v in the matrix

clause. Therefore, grammar supplies C with an EPP-feature in this context, and the DP-complement of the resumptive pronoun can move to [Spec, C] from where it is accessible to a probe in the matrix clause. In contrast, when there is no ‚big’ DP in the embedded clause, only T is associated with an EPP-feature, and even though the subject DP also agrees with uF on C, no movement of the lexical subject to [Spec, C] takes place.⁴⁶

6.5 Conclusion

I have developed a theory of long A-movement that expands and elaborates the analysis outlined in chapter 5. I have argued that a language has long A-movement if it (1.) can form a ‚big’ DP whose head does not assign case to, but which allows extraction of, its complement DP, and (2.) if it has Raising and ECM-verbs which select CPs with an uF-feature.⁴⁷ Empirical data from some of the languages under consideration, as well as the theoretical discussion provided in this chapter, support the conclusion that C in languages with long A-movement has a grammatical feature that can enter an Agree-relation with DP_{COMPL}. The existence of this feature implies that subsequent movement of DP_{COMPL} to [Spec, C], which is triggered by the edge (or EPP-) feature of C, counts as A-movement. DP_{COMPL} in [Spec, C] hence remains accessible for further Agree-relations with functional heads in the matrix clause, and can undergo further A-movement. Importantly, although the nature of the feature uF on C which enters the first Agree-relation with DP_{COMPL} may vary from language to language, all other aspects of my analysis of long A-movement constructions (the ‚big’ DP, the Agree-relation between C and DP_{COMPL}, and A-movement to [Spec, C]) can be applied to, and explain the properties of, Hyperraising, Hyper-ECM and Copy Raising constructions in all the languages I have examined here. This means that my analysis has shown that it is possible to explain the possibility of long A-movement in different languages through one and the same underlying mechanism.

An interesting implication of my account is that the main difference between a construction with and one without A-movement is not found in the nature of the CP

⁴⁶ Note that an edge-feature on C can still be licensed in constructions without ‚big’ DP if it has an effect on the outcome, e.g. in order to allow long A-bar movement of a wh-phrase.

⁴⁷ Given Pesetsky & Torrego’s (2001, 2004) analysis, English has the latter property, i.e. a uT-feature on C. The impossibility of long A-movement in English suggests that English does not have the first property, i.e. it cannot create ‚big’ DP-constructions which allow resumption in A-movement contexts.

(strong vs. weak phase; indicative vs. subjunctive etc.), but in the nature of the embedded subject. Apart from the EPP-feature on C, which is present only when movement occurs, the properties of a CP from which the subject is extracted are identical to those of the CPs whose subjects have remained *in situ*. In each case, CP is a strong phase, and if it is selected by a Raising or ECM-verb, its head bears an uF-feature which needs to enter an agreement relation with a DP acting as a goal. The difference between the variants with and those without A-movement is the structure of the thematic subject: if it is an ordinary DP, this DP can act as a goal for two probing heads, but if it is a ‚big‘ DP, the uF-probe of C targets the lexical DP-complement inside big DP, and the EPP-feature associated with C attracts this DP to [Spec, C], ultimately creating a long A-movement construction with a stranded resumptive pronoun in the embedded clause.

CHAPTER 7

Conclusion

In this chapter, I summarise the main points of the thesis. 7.1 summarises the research findings, while 7.2 highlights the outstanding problems and suggests areas of further research.

7.1 Summary of thesis

The standard treatment of Raising constructions in recent versions of Generative Grammar, such as the Minimalist Program (Chomsky, 1995, 2001, 2005) is based on the premise that Raising is only possible from defective clauses. In contrast to this assumption, which I discussed in detail in chapter 1, I have shown in my thesis that a large number of languages allow A-movement out of finite complement clauses. In chapter 2, I presented data from Shona, Kikuyu and Kiruúndi collected during my own fieldwork, as well as data from the literature that illustrate that many languages manifest long subject-to-subject Raising out of finite complements: Kipsigis (Jake & Odden, 1979); Kikuyu, Kiruúndi and Shona (Perez 1985); Kitharaka (Harford (Perez) 1997); Rumanian (Grosu & Horvath, 1984; Rivero, 1991); Hebrew (Lappin, 1984); Haitian Creole (Deprez, 1992); Turkish (Moore, 1998; Aygen, 2004); Igbo (Ura, 1998); Greek (Joseph, 1976; Soame & Perlmutter, 1979; Alexiadou & Anagnostopoulou, 1999); Japanese (Uchibori, 2000, 2001;); Brazilian Portuguese (Rodrigues, 2004; Martins & Nunes, 2006); Yoruba (Adesola, 2005); Mandarin Chinese (Li, 1990; Ura, 1994); Zulu (Zeller, 2006a, 2006b); Telugu (Ura 1994); Persian (Darzi, 1993); Finnish (Sulkala & Karjalainen, 1992 Ura, 1994); Dholuo (Creider, 1989; Ura, 1994); Moroccan Arabic (Ura, 1994); Bhojpuri (Shukla, 1981; Ura, 1994) and Maithili (Yadava, 1989). In chapter 3, I further presented data from the literature on languages that manifest long subject-to-object Raising out of finite complements: Greek (Joseph, 1976); Rumanian (Rivero, 1991); Korean (Hong 2005); Japanese (Bruening, 2001; Tanaka, 2002); Turkish (Şener, 2008); Herero (Kavari & Marten, 2005); Quechua and Kipsigis (Jake & Odden, 1979); Chamorro (Gibson, 1992; Davies and Dubinsky, 2004); Fijian and Niuean (Massam, 1985) and Dholuo (Gu, 2009). I observed that an embedded subject DP can be moved to

the matrix subject or object position, not only from finite subjunctive complements in languages such as Greek, Japanese and Rumanian, but also from finite indicative clauses in languages such as Turkish, Brazilian Portuguese and many Bantu languages. In some cases (e.g. in languages like Yoruba, Igbo, Haitian Creole and Hebrew), a subject DP that is moved out of a finite clausal complement leaves a pronominal copy at the point of extraction.

In chapter 4, I reviewed existing analyses of long A-movement that exist in the Minimalist Program. Some authors have suggested that T inside the embedded CP that allows long A-movement of its subject is defective, and that this defectiveness is the result of the lack of tense (Alexiadou & Anagnostopoulou, 1999; Uchibori, 2000, 2001), mood (Aygen, 2004) or because of the nominal nature of T (Zeller, 2006a). The proponents of the ‚case assignment’ approach argue that although case can be assigned in the embedded CP, case assignment could be delayed if there was no expletive in the numeration to satisfy the EPP feature of the matrix T (Rodrigues, 2004). Moreover, Ura (1998), argues that the case feature of the embedded subject DP and the ϕ -features of the embedded T are not checked in the embedded clause because case valuation is only required for convergence. In the small clause approach, Deprez (1992) and Kawai (2006) argue that the embedded DP moves because the embedded clause is a small clause, while the base generation analysis assumes that a copy pronoun originates in the embedded clause, and that the matrix subject DP is base generated in the matrix subject position (Harford (Perez), 1997; Potsdam and Runner, 2001; Hoji, 2005). I noted that there are various problems with these existing theories. For instance, the fact that full agreement is normally only attested in non-defective clauses poses a problem for the proposal that the embedded CP in Hyperraising and Hyper-ECM constructions is defective, since the embedded T in these constructions triggers full agreement. Also, the observation that it is possible for the base position of an extracted subject in long A-movement constructions to be overtly realised as a pronominal copy indicates that case is assigned in the embedded clause from which long A-movement has taken place, which contradicts the assumption that case assignment is delayed and does not happen in the embedded clause. Furthermore, I noted that the existing theoretical approaches are not uniform, and that

they are mostly motivated by the idiosyncratic properties of the respective language under investigation. An account which is based on an idiosyncratic property of a specific language can naturally not be extended to a language which does not have that property. Therefore, I have attempted a unified approach which explains what is essentially the same phenomenon in terms of the same theoretical assumptions, rather than using different, and often unrelated, theories.

In chapter 5, I outlined the first part of my own analysis of long A-movement constructions. I noted that what all the Hyperraising and Hyper-ECM constructions discussed in chapters 2 and 3 have in common is that they license null subjects (*pro*-DPs) – a correlation that I labelled *Ura's generalisation* (after a similar observation made in Ura 1994). I also took into account the observation that pro drop languages like Shona, Greek and Japanese allow Hyperraising and Hyper-ECM, while non pro drop languages like Yoruba and Igbo have Copy Raising. Based on this observation and Ura's generalisation, I then suggested that languages which allow Hyperraising and Hyper-ECM must be pro drop languages because the gap in the subject position of the embedded finite clauses from which Hyperraising and Hyper-ECM has occurred is filled by *pro*. In languages with Copy Raising, which do not have null pronouns, the embedded subject position is realised by an overt pronoun. In this way, my proposal provides an obvious bridge between languages which allow Hyperraising and Hyper-ECM and those languages with Copy Raising: these constructions are identical in all crucial respects, with the main difference being that the pronominal resumptive copy is a full lexical pronoun in the latter languages, whereas it is a null pronoun in languages with Hyperraising and Hyper-ECM. The main conclusion of chapter 5 is that the data discussed in chapters 2 and 3, in which an A-moved matrix subject or object is linked to the subject position of an embedded finite clause, are best captured if it is assumed that this embedded subject position is filled with a (null or overt) subject pronoun which is coreferential with the moved DP. This proposal amounts to saying that A-movement of DPs out of finite clauses triggers *resumption*, i.e. the occurrence of a (null) pronoun in the embedded subject position.

Chapter 5 also provides a technical implementation of the suggested theory of resumption in long A-movement constructions. I have argued that languages with Hyperraising, Hyper-ECM or Copy Raising allow for the formation of recursive ‚big‘ DPs, i.e. DPs in which a pronominal head selects another DP (DP_{COMPL}), in the subject position of embedded finite clauses. The theta-role associated with the subject is assigned to the complex ‚big‘ DP, which includes DP_{COMPL} . The ‚big‘ DP also agrees with the embedded T, its case feature is valued as nominative, and the DP moves to [Spec, T]. However, although the whole ‚big‘ DP counts as the argument of the embedded verb, both DPs need case. Assuming that pronominal DPs are not case assigners, this means that DP_{COMPL} still has an unvalued case feature. It therefore is still active, and its ϕ -features are available as the goal for a probe in the matrix clause. Eventually, DP_{COMPL} moves out of the embedded clause into the matrix clause, leaving behind the remnant ‚big DP‘, stranding its pronominal head (which is *pro* in languages with Hyperraising and Hyper-ECM and an overt pronoun in Copy Raising languages). As I have shown, the proposal that recursive DPs can be formed to allow the generation of “extra” DPs makes the interesting prediction that we also find instances of “successive-cyclic” long A-movement, and I presented data to demonstrate that this prediction is indeed realised in languages such as Shona, Greek, Turkish, Japanese, Chinese and Korean.

In contrast to Ura (1994) and many of the analyses of Hyperraising and Hyper-ECM discussed in Chapter 4, my proposal does not imply that long A-movement is only possible from clauses whose embedded T-head is defective, or that the embedded subject position is a non-case position. Rather, I take agreement inside the embedded clause to be indicative of the ability of embedded T to license nominative case on the embedded subject. In this respect, no deviation from standard Minimalist assumptions is required. More specifically, I suggested in chapter 5 that the role of the resumptive *pro* or overt pronoun in Hyperraising, Copy Raising or Hyper-ECM constructions is precisely to receive the case assigned by the probing T-head inside the embedded clause. It is the existence of a resumptive pronoun which causes the coreferential subject DP to be without case, which in turn creates a context in which long A-movement of this DP becomes possible.

One of the key questions that is not yet answered by the analysis presented in chapter 5 is why the embedded DP_{COMPL} is accessible for a higher functional head, despite an intervening finite CP-boundary. My explanation of this possibility, which I motivate and develop in detail in chapter 6, is based on the idea that finite CPs are phases, but that a phrase that undergoes Raising out of a finite CP escapes the CP by moving through the edge of the phase, i.e. through [Spec, C]. In other words, I assume that long A-movement never proceeds directly from the embedded subject position to an A-position in the main clause. Rather, I suggested that it always proceeds in a successive-cyclic manner via the embedded [Spec, C]-position.

In order to explain that DP_{COMPL} , once moved to [Spec, C], can undergo further A-movement into a matrix clause, I challenged the assumption that movement to [Spec, C] is always A-bar movement, and argued instead that in Hyperraising, Hyper-ECM and Copy Raising constructions, [Spec, C] can become an A-position. I proposed, following Chomsky (2006: 6), that all lexical items which can be merged have edge-features; it is the edge-features of lexical items that allow them to combine with other lexical items or phrases to derive larger syntactic objects. I argued that whether movement triggered by an edge feature counts as A- or A-bar movement depends on the feature content of the head whose edge-feature triggers movement. I suggested that movement triggered by an edge-feature on a head H is A-movement if the head bears an uninterpretable formal feature that acts as a probe in an Agree relation. This suggestion led me to the further assumption that the C-head of an embedded finite clause in long A-movement constructions must be equipped with a formal feature uF , which enters an Agree-relation with the embedded subject DP_{COMPL} . Much of the discussion in chapter 6 was devoted to the presentation of conceptual and empirical arguments in favour of this analysis.

7.2 Suggested further research

One limitation of the present study has to do with the available data. Most of the data discussed in chapters 2 and 3 were adopted from existing literature. In many cases, my analysis gave rise to certain questions or expectations that I would have liked to test by

checking more and different examples from the respective languages. However, due to obvious geographical constraints, it was not always possible to gain access to mother-tongue speakers of the relevant languages mentioned in the study to substantiate and further develop claims about Hyperraising, Copy Raising or Hyper-ECM in these languages.

As already noted at the end of chapter 6, my proposal that the feature uF on C which acts as a probe for an Agree-relation with DP_{COMPL} is an uninterpretable and unvalued *categorial feature* $uCAT$, and that the goal for this probe is the subject's categorial D-feature, should be further investigated. It is expected that such an investigation will result in finding at least some languages in which Hyperraising, Copy Raising or Hyper-ECM is accompanied by visible agreement between the categorial feature of an embedded lexical subject and the uninterpretable categorial feature of a complementiser. That is, one expects to find languages in which A-movement takes place out of finite clauses with determiner-like complementisers.

Although the analysis proposed in this study accounts for the properties of Hyperraising and Hyper-ECM across several languages, it does not account for the type of Raising found with Spanish predicates like *parece* 'seems':

- (1) a. *pro* parece que Juan y Pedro son muy listos
It seems that John and Peter are very smart
'It seems that John and Peter are very smart.'
- b. Juan y Pedro parece que son muy listos
John and Peter seems that are very smart
'John and Peter seem to be very smart.'

- (2) mala hierba parece que nunca muere
 bad herb seems that never dies
 ‚A bad herb seems never to die.‘ (literal)
 ‚A bad person seems to live for a long time.‘ (idiomatic)

(Fernández-Salgueiro:2005: 100-102)

Like Hyperraising and Hyper-ECM constructions discussed in chapters 2 and 3, *parece* ‚seems‘ also licenses an expletive *pro* and alternatively triggers what looks like Raising from a finite complement, (1). The idiomatic interpretation is also retained when the subject-part of an idiom embedded under *parece* is moved to the matrix clause, as illustrated by the example in (2). However, as observed in (1b), the raised DP *Juan y Pedro* ‚John and Peter‘ fails to trigger agreement with the matrix T: the matrix verb shows (default) singular agreement, and no plural number agreement with the extracted subject DP.

A similar example is also found with Greek predicates like *ine piθano* ‚is likely‘. The predicate *ine piθano* behaves like the Hyperraising and Hyper-ECM predicates discussed in chapters 2 and 3 in many respects, as shown in the following examples:

- (3) a. *pro* ine piθano oti i kopeles ða fevgun
 pro is likely COMP the girls-NOM FUT-leave-3PL
 ‚It is likely that the girls will leave.‘
- b. i kopeles ine piθano na fevgun
 the girls-NOM is likely SUBJ leave-3PL
 ‚The girls are likely to be leaving.‘
- (4) a. O Janis ine piθano na apoperatosi to ergo
 the-NOM.MASC John is likely SUBJ to finish/complete the-NOM.NEUT task
 ‚John is likely to finish /complete the task.‘

- b. to ergo ine piθano na apoperatoei
 the- NOM.NEUT task is likely SUBJ to finish/complete-3SING.PASS
 apo to Jani
 by the-ACC. MASC John
 „The task is likely to be finished/completed by John.’
- (5) a. *pro* ine piθano o kombos na ftasi sto xteni
 pro is likely the- NOM. MASC knot SUBJ arrive-at-the comb
 „It is likely that the knot will arrive at the comb.’
 „It is likely that things will come to a head.’
- b. o kombos ine piθano na ftasi sto xteni
 the- NOM. MASC knot is likely SUBJ arrive-at-the comb
 „The knot is likely to arrive at the comb.’ (literal)
 „Things are likely to come to a head.’ (idiomatic)

Like the Spanish predicate *parece* ‚seems’, *ine piθano* ‚is likely’ takes an expletive *pro* subject in (3a) and triggers Raising out of a finite complement in (3b). In (4), when the verb embedded under *ine piθano* is passivised, both active and passive sentences are similar in meaning, and (5) shows that when the subject-part of an idiom chunk embedded under *ine piθano* is raised to the matrix clause, the sentence still retains its idiomatic meaning. However, in contrast to the Hyperraising and Hyper-ECM constructions discussed in chapters 2 and 3, the raised subject in *ine piθano* constructions does not trigger agreement with the matrix T, as seen in (6):

- (6) *i kopeles ine piθanes na fevgun
 the girls- NOM are likely SUBJ leave-3PL
 „The girls are likely to be leaving.’

It is interesting to note that in the expletive variant of the idiomatic construction (5a), the subject of the embedded clause precedes the subjunctive complementiser *na* and bears

nominative case. My analysis predicts constructions such as (5) to be possible. A language which has the expletive construction: EXPL-V [COMPL-subj-V] and the alternative Raising variant: subject-V [COMPL- *pro*- V] should also have EXPL-V [subj-COMPL- V] structure where the subject has raised to [Spec, C] but no further. However, in general, constructions like (5) do not seem to be attested in most of the languages which have both long A-movement and the corresponding expletive constructions, as shown by the Zulu example in (7) taken from Zeller (2006b: 6):

- (7) a. *Ku-fanele abantwana ukuthi ba-dlal-e ngaphandle
 LOC-ought child2 that SM2-play-SUBJ outside
 „The children must play outside.’
- b. [CP [TP EXPL [verb [CP DP_{COMPL} [C' C [TP [DP PRON ~~DP_{COMPL}~~] [T' ...

If structural case is assigned under Agree, and if the EPP-feature of T is independent of case-assignment and can be checked by an expletive, then it is unclear why (to the best of my knowledge) examples with the word order in (7) are not attested in most of the languages examined in this thesis.

However, it is well possible that the absence of data with the word order in (7) is due to another reason. It has become part of the standard analysis of the Minimalist Program since Chomsky (2000) to assume that all that is required for case assignment is that the case-assigning head C-commands the respective DP. However this assumption has been challenged by various authors in recent years (Epstein & Seely, 2006). If these alternative proposals are on the right track, then it could indeed be possible that nominative case-assignment actually requires a Spec-Head relation between T and the DP, exactly as was assumed in earlier versions of the Principles and Parameters theory before Chomsky (2000). If this is the case, then the impossibility of examples such as (7) follows without further stipulations: although DP_{COMPL} in (7) has entered an agreement relation with uF on C and has been attracted to [Spec, C] because of C's edge (= EPP-) feature, and although it could possibly even Agree with matrix T or v from this position, DP_{COMPL}

would still not be able to have its case feature valued by T if it remained in [Spec, C]. For nominative case to be assigned, DP_{COMPL} would have to move to [Spec, T] or [Spec, v] of the matrix clause. If this movement step does not take place, the derivation will crash.

As far as I can see, the analysis of long A-movement presented in my thesis is entirely compatible with the idea that case assignment requires a Spec-Head relation. This idea would also explain that the ‚big’ DP which includes the resumptive pronoun is always located in the embedded [Spec, T]-position: the ‚big’ DP cannot be stranded in the embedded [Spec, v], since [Spec, T] is the only position in which it can receive nominative case. On the basis of the apparent absence of data with the word order in (7), I therefore tentatively conclude that my analysis, if correct, provides further evidence for the (old) idea that structural case can only be assigned if the relevant case assigner and assignee are in a Spec-Head relation.

REFERENCES

- Abney, S.P. (1987). *The English noun phrase in its sentential aspect*. Unpublished Doctoral Dissertation, MIT.
- Adesola, O. (2005). *Pronouns and null operators-A bar dependencies and relations in Yoruba*. Unpublished Ph.D, The State University of New Jersey.
- Aissen, J. (1974). Verb Raising. *Linguistic Inquiry*, 5, 325-366.
- Alexiadou, A., & Anagnostopoulou, E. (1998). Parameterizing Agr: Word order, V-movement, and EPP-checking. *Natural Language and Linguistic Theory*, 16, 491-539.
- Alexiadou, A., & Anagnostopoulou, E. (1999). Raising without infinitives and the nature of agreement. In S. Bird, A. Carnie, J. Haugen & P. Norquest (Eds.), *WCCFL 18 Proceedings* (pp. 15-25.).
- Alexopoulou, T. (2006). Resumption in relative clauses. *Natural Language and Linguistic Theory*, 24, 57-111.
- Aoun, J., Choueiri, L., & Hornstein, N. (2001). Resumption, movement, and derivational economy. *Linguistic Inquiry*, 32(3), 371-403.
- Asudeh, A. (2004). *Resumption as resource management*. Unpublished Doctoral dissertation, Stanford University.
- Asudeh, A., & Toivonen, I. (2007). *Copy Raising and Perception*. Unpublished manuscript, Carleton University, Ottawa, Ontario.
- Aygen, G. (2004). Finiteness, case and agreement. In C. Vineeta (Ed.), *WCCFL 23* (pp. 57-70): Somerville, MA: Cascadilla Press.
- Baker, M.C. (1988). *Incorporation*. Chicago: Chicago University Press.
- Baker, M.C. (2003). *Verbs, nouns, and adjectives: Their universal grammar*. Cambridge: Cambridge University Press.
- Bayer, J. (1984). COMP in Bavarian syntax. *The Linguistic Review*, 9, 209-274.
- Bennis, H., & Haegeman, L. (1984). On the status of agreement and relative clauses in West Flemish. In W. de Geest & Y. Putseys (Eds.), *Sentential complementation*. Dordrecht: Foris.
- Bianchi, V. (2000). The raising analysis of relative clauses: A reply to Borsley. *Linguistic Inquiry*, 31(1), 123-140.
- Binnick, R.I. (1991). *Time and the verb*. Oxford: Oxford University Press.

- Bobaljik, J.D. (2002). A-chains at the PF-interface: Copies and 'covert' movement. *Natural Language and Linguistic Theory*, 20(2), 197-267.
- Boeckx, C. (2003). *Islands and Chains*. Amsterdam: John Benjamins.
- Boeckx, C., & Hornstein, N. (2006). The virtues of control as movement. *Syntax*, 9(2), 118-130.
- Borer, H. (1986). *The syntax of pronominal clitics*. Orlando: Academic Press.
- Bresnan, J., & Kanerva, J. (1988). Locative inversion in Chichewa: A case study of factorization in grammar. *Linguistic Inquiry*, 20, 1-50.
- Broekhuis, H. (2007). Object shift and subject shift. *The Journal of Comparative Germanic Linguistics*, 10(2), 109-141.
- Bruening, B. (2001). *Raising to object and proper movement*. Unpublished manuscript.
- Carlson, R. (1992). Narrative, subjunctive, and finiteness. *Journal of African Languages and Linguistics*, 13, 59-85.
- Carstens, V. (2001). Multiple agreement and case deletion: Against ϕ -(in)completeness. *Syntax*, 4(3), 147-163.
- Carstens, V. (2003). Rethinking complementiser agreement: Agree with a case-checked goal. *Linguistic Inquiry*, 34(3), 393-412.
- Cecchetto, C. (1999). A comparative analysis of left and right dislocation in Romance. *Studia Linguistica*, 53, 40-67.
- Cecchetto, C. (2000). Doubling structure and reconstruction. *Probus*, 12, 93-126.
- Cecchetto, C. (2001). Syntactic or semantic reconstruction? In C. Cecchetto, G. Chierchia & M. T. Guasti (Eds.), *Semantic interfaces: Reference, anaphora and aspect*. Stanford: CSLI Publications.
- Chomsky, N. (1965). *Aspects of the theory of syntax*. Cambridge: MIT Press.
- Chomsky, N. (1970). Remarks on nominalization. In R. Jacobs & P. Rosenbaum (Eds.), *Readings in English Transformational Grammar* (pp. 184-221). Waltham, Massachusetts: Ginn and Co.
- Chomsky, N. (1973). Conditions on transformation. In S. Anderson & P. Kiparsky (Eds.), *A festschrift for Morris Halle* (pp. 232-286). New York: Holt, Rinehart and Winston.
- Chomsky, N. (1977). On wh-movement. In P. Culicover, T. Wasow & A. Akmajian (Eds.), *Formal Syntax* (pp. 71-132). New York: Academic Press.

- Chomsky, N. (1981). *Lectures on government and binding*. Dordrecht: Foris.
- Chomsky, N. (1982). *Some concepts and consequences of the theory of government and binding*. Cambridge: MIT Press.
- Chomsky, N. (1986a). *Knowledge of language: Its nature, origin and use*. New York: Praeger.
- Chomsky, N. (1986b). *Barriers*. Cambridge: MIT Press.
- Chomsky, N. (1993). A minimalist program for linguistic theory. In K. Hale & S. J. Keyser (Eds.), *The view from building 20*. Cambridge, Massachusetts: MIT Press.
- Chomsky, N. (1995). *The minimalist program*. Cambridge: MIT Press.
- Chomsky, N. (2000). Minimalist inquiries: The framework. In R. Martin, D. Michael & J. Uriagereka (Eds.), *Step by Step: Essays on Minimalist Syntax in honour of H. Lasnik* (pp. 89-155). Cambridge: MIT Press.
- Chomsky, N. (2001). Derivation by phase. In M. Kenstowicz (Ed.), *Ken Hale: A life in Language* (pp. 1-52). Cambridge: MIT Press.
- Chomsky, N. (2004). Beyond explanatory adequacy. In A. Belletti (Ed.), *The cartography of syntactic structures: Structures and beyond* (Vol. Volume 3, pp. 104-131). Oxford: Oxford University Press.
- Chomsky, N. (2005). Three factors in language design. *Linguistic Inquiry*, 36, 1-22.
- Chomsky, N. (2007). Approaching UG from below. In U. Sauerland & H. Gärtner (Eds.), *Interfaces + Recursion = Language?* (pp. 1-29). Berlin: Mouton de Gruyter.
- Chomsky, N. (2008). On phases. In R. Freidin, C. Otero & M. Zubizarreta (Eds.), *Foundational issues in linguistic theory* (pp. 133-166). Cambridge, MA: The MIT Press.
- Chomsky, N., & Lasnik, H. (1995). *The theory of principles and parameters*. Berlin: De Gruyter.
- Chung, S. (1982). Unbounded dependencies in Chamorro. *Linguistic Inquiry*, 13, 39-77.
- Chung, S. (1994). Wh-agreement and 'referentiality' in Chamorro. *Linguistic Inquiry* 25, 1-44.
- Chung, S. (1998). *The design of agreement: Evidence from Chamorro*. Chicago: University of Chicago Press.
- Cinque, G. (1977). The movement nature of left dislocation. *Linguistic Inquiry*, 8(2), 397-411.

- Cole, P., & Hermon, G. (1981). Subjecthood and islandhood: Evidence from Quechua. *Linguistic Inquiry*, 12(1), 1-30.
- Cowper, E. (2002). *Finiteness*. Unpublished manuscript, University of Toronto.
- Creider, C. (1989). *The syntax of Nilotic languages*. Berlin: Dietrich Reimer Verlag.
- Darzi, A. (1993). Raising in Persian. In *Proceedings of the Eastern States Conference* (pp. 81-92). Columbus, Ohio: Ohio State University.
- Darzi, A. (2008). On the vP analysis of Persian finite control constructions. *Linguistic Inquiry*, 39(1), 103-116.
- Davies, W.D., & Dubinsky, S. (2004). *The grammar of raising and control: A course in syntactic argumentation*. Massachusetts, Oxford, Victoria: Blackwell Publishing.
- De Haan, G., & Weerman, F. (1986). Finiteness and verb fronting in Frisian. In H. Haider & M. Prinzhorn (Eds.), *Verb second phenomena in germanic languages* (pp. 77-110). Dordrecht: Foris.
- Demuth, K. (1990). Locatives, impersonals and expletives in Sesotho. *The Linguistic Review*, 7(3), 233-249.
- Déprez, V. (1992). Raising construction in Haitian Creole. *Natural Language and Linguistic Theory* 10, 191-231.
- Diesing, M. (1996). Semantic variables and object shift. In H. Thráinsson, S. D. Epstein & S. Peters (Eds.), *Studies in comparative germanic syntax II* (pp. 66-84). Dordrecht: Kluwer.
- Du Plessis, H. (1977). Wh movement in Afrikaans. *Linguistic Inquiry*, 8, 723-726.
- Elbourne, P. (2001). Donkey anaphora as NP-ellipsis. In *Proceedings of WCCFL 19* (pp. 83-96). Somerville, Massachusetts: Cascadilla Press.
- Engdahl, E. (1985). Parasitic gaps, resumptive pronouns and subject extractions. *Linguistics*, 23, 3-44.
- Epstein, S.D. and T.D. Seely (2006). *Derivations in Minimalism*. Cambridge: Cambridge University Press.
- Escobar, L. (1997). Clitic left dislocation and other relatives. In E. Anagnostopoulou, H. Riemsdijk & F. Zwarts (Eds.), *Materials on left dislocation*. Amsterdam: John Benjamins.
- Felser, C. (2004). Wh-copying, phases, and successive cyclicity. *Lingua*, 114, 543-574.

- Gess & E. Rubin (Eds.), *Experimental and theoretical approaches to Romance linguistics* (pp. 97-107). Amsterdam: John Benjamins.
- Ferreira, M. (2000). *Argumentos Nulos em Português Brasileiro*. Unpublished MA Thesis, University of Campinas, Campinas.
- Finer, D.I. (1997). Contrasting A-bar dependencies in Selayarese. *Natural Language and Linguistic Theory*, 15, 677-728.
- Fox, D. (1994). Relative clauses and resumptive pronouns in Hebrew- An optimality theoretic approach. MIT.
- Fuß, E. (2004). *A post-syntactic approach to complementiser agreement*. Unpublished manuscript, University of Frankfurt.
- George, L.M., & Kornfilt, J. (1981). Finiteness and boundedness in Turkish. In F. Heny (Ed.), *Binding and Filtering* (pp. 105-127). Massachusetts, Cambridge: MIT Press.
- Gibson, J.D. (1992). *Clause union in Chamorro and in universal grammar*. New York: Garland Publishing, Inc.
- Grimshaw, J. (1979). Complement selection and the lexicon. *Linguistic Inquiry*, 10(2), 279-326.
- Grosu, A., & Horvath, J. (1984). The GB theory and raising in Rumanian. *Linguistic Inquiry*, 15, 348-353.
- Gu, C.C. (2009). *Subject and object affixes in Dholuo*. Unpublished manuscript.
- Haegeman, L. (1990). Subject pronouns and subject clitics in West Flemish. *The Linguistic Review*, 7, 333-363.
- Haegeman, L. (1992). *Theory and description in generative syntax: A case study in West Flemish*. Cambridge: Cambridge University Press.
- Haegeman, L. (1994). *Introduction to government and binding theory* (second ed.). Cambridge: Basil, Blackwell.
- Haji-Abdolhosseini, M., Massam, D., & Oda, K. (2002). Number and events: Verbal reduplication in Niuean. *Oceanic Linguistics*, 41.
- Hale, K., & Keyser, S.J. (1993). On argument structure and the lexical expression of syntactic relations. In K. Hale & S. J. Keyser (Eds.), *The view from building 20:*

- Essays in honor of Sylvain Bromberger* (pp. 53-109). Cambridge, Massachusetts: MIT Press.
- Harford (Perez), C. (1990). Locative inversion in Chishona. In Hutchison, J. P. & Manfredi, V. (Eds.), *Current approaches to african linguistics* (pp. 137-144).
- Harford (Perez), C. (1997). Empty operator raising in Kitharaka. *Studies in African Linguistics*, 26(2).
- Harrel, S.R. (1962). *A short reference grammar of Moroccan Arabic*. Washington, D.C.: Georgetown University Press.
- Harrel, S.R. (2004). *A short reference grammar of Moroccan Arabic*. Washington D.C.: Georgetown University Press.
- Henderson, B. (2006a). Multiple agreement and inversion in Bantu. *Syntax*, 9(3), 275-289.
- Henderson, B. (2006b). *The syntax and typology of Bantu relative clauses*. Unpublished PhD, University of Illinois Urbana-Champaign.
- Henry, A. (1995). *Belfast English and Standard English: Dialect variation and parameter setting*. Oxford: OUP.
- Hiemstra, I. (1986). Some aspects of wh-questions in Frisian. *North-Western European Language Evolution*, 8, 97-110.
- Hiraiwa, K. (2005). *Dimensions of symmetry in syntax: Agreement and Clausal architecture*. Unpublished PhD thesis, MIT.
- Hoekstra, J., & Marác, L. (1989). On the position of inflection in West Germanic. *Working Papers in Scandinavian Syntax*, 44, 75-88.
- Hoji, H. (2005). *A major object analysis of the so-called raising-to-object construction in Japanese (and Korean)*. Paper presented at the Korean/Japanese Syntax and Semantics Workshop.
- Holmberg, A. (1986). *Word order and syntactic features in the Scandinavian Languages and English*. Unpublished Ph.D, University of Stockholm, Stockholm.
- Holmberg, A. (2000). Scandinavian stylistic fronting: How any category can become an expletive. *Linguistic Inquiry*, 31(3), 445-483.
- Holmberg, A., & Platzack, C. (1995). *The role of inflection in Scandinavian syntax*. New York: Oxford University Press.

- Hong, S.-M. (2005). *Exceptional case-marking and resultative constructions*. Unpublished PhD, University of Maryland, Maryland, College Park
- Huang, C.-T.J. (1984). On the distribution and reference of empty pronouns. *Linguistic Inquiry*, 15(4), 531-574.
- Iatridou, S. (1993). On nominative case assignment and a few related things. In C. Phillips (Ed.), *Papers on case and agreement II* (pp. 175-196). Cambridge, Mass.: MIT.
- Jake, J., & Odden, D. (1979). Raising in Kipsigis. *Studies in the Linguistic Sciences*, 9(2), 131-155.
- Johnson, K. (1991). Object positions. *Natural Language and Linguistic Theory*, 9(4), 577-636.
- Joseph, B.D. (1976). Raising in modern Greek: A copying process?*. *Harvard Studies in Syntax and Semantics*, 2, 241-281.
- Kavari, J.U., & Marten, L. (2005). *Tone cases in Herero: the coding of head-complement relations, linear order, and information structure*. Unpublished manuscript.
- Kawai, M. (2006). Raising to object in Japanese. *Linguistic Inquiry*, 37(2), 329-339.
- Kayne, R. S. (1994). *The antisymmetry of syntax*. Cambridge, Mass.: MIT Press.
- Koizumi, M. (1993). Object agreement phrases and the split VP hypothesis. In *MIT working papers in linguistics 18: Papers on case and agreement I*. Cambridge, Massachusetts: MITWPL, Department of Linguistics and Philosophy, MIT.
- Koizumi, M. (1995). *Phrase structure in minimalist syntax*. Unpublished Ph.D, MIT, Cambridge, Massachusetts.
- Kornfilt, J. (1977). A note on subject raising. *Linguistic Inquiry*, 6, 494-501.
- Krapova, I. (1998). Subjunctive complements, null subjects and case checking in Bulgarian. *University of Venice Working Papers in Linguistics*, 8(2), 73-93.
- Krishnamurti, B., & Gwynn, J.P.L. (1985). *A grammar of modern Telugu*. Oxford: Oxford University Press.
- Kroch, A. (1981). On the role of resumptive pronouns in amnestying Island constraint violations. In *Papers from the 17th regional meeting of the Chicago Linguistic Society* (pp. 125-135). Chicago, Illinois: Chicago Linguistic Society.

- Kuno, S. (1976). Subject Raising. In M. Shibatani (Ed.), *Syntax & Semantics 5: Japanese generative grammar* (pp. 17-49). New York: Academic Press.
- Landau, I. (2004). The scale of finiteness and the calculus of control. *Natural Language and Linguistic Theory*, 22, 811-877.
- Landau, I. (2009). This construction looks like a copy is optional. *Linguistic Inquiry*, 4(2), 343-346.
- Lappin, S. (1984). Predication and raising. *Proceedings of North Eastern Linguistics Society (NELS) 14*, 236-352.
- Larson, R.K. (1988). On the double object construction. *Linguistic Inquiry*, 19(3), 335-391.
- Larson, R.K. (1990). Double objects revisited: Reply to Jackendoff. *Linguistic Inquiry*, 21, 589-632.
- Lee, D.-W. (2003). Two types of object and object shift. *Studies in Generative Grammar*, 13(4), 565-595.
- Lee, J.-S. (1992). *Case alternations in Korean: Case minimality*. Unpublished PhD Dissertation, University of Connecticut.
- Lee, W., & Cho, S. (2003). Argument scrambling and object shift. *Studies in Generative Grammar*, 13(1), 39-59.
- Lefebvre, C., & Muysken, P. (1982). Raising as move case. *The Linguistic Review*, 2, 161-210.
- Legate, J. A. (2003). Some interface properties of the phase. *Linguistic Inquiry*, 34(3), 506-515.
- Li, Y.A. (1990). *Order and Constituency in Mandarin Chinese*. Dordrecht, Boston, London: Kluwer Academic Publishers.
- Martin, R. (2001). Null case and the distribution of PRO. *Linguistic Inquiry*, 32(1), 141-166.
- Martins, A.M., & Nunes, J. (2006). *Raising issues in Brazilian and European Portuguese*. Unpublished manuscript.
- Massam, D. (1985). *Case theory and the projection principle*. Unpublished PhD Dissertation, MIT.
- Matushansky, O. (2002). Tipping the scales: The syntax of scalarity in the complement of SEEM. *Syntax*, 5(3), 219-276.

- Matushansky, O. (2006). Head movement in linguistic theory. *Linguistic Inquiry*, 37(1), 69-109.
- McCloskey, J. (1979). *Transformational syntax and model-theoretical semantics: A case study in modern Irish*. Dordrecht: D. Reidel.
- McCloskey, J. (1984). Raising, subcategorization and selection in modern Irish. *Natural Language and Linguistic Theory* 1, 441-485.
- McCloskey, J. (1990). Resumptive pronouns, \bar{A} -binding and levels of representation in Irish. In R. Hendrick (Ed.), *The syntax and semantics of modern Celtic languages*. San Diego: Academic Press.
- McCloskey, J. (2000). Quantifier float and wh-movement in an Irish English. *Linguistic Inquiry*, 31(1), 57-84.
- McCloskey, J. (2001). The morphosyntax of wh-extraction in Irish English. *Journal of Linguistics*, 37, 67-100.
- McCloskey, J. (2002). Resumption, successive cyclicity and the locality of operations In S. D. Epstein & T. D. Seely (Eds.), *Derivation and explanation in the minimalist program*. Oxford: Blackwell.
- McCloskey, J., & Sells, P. (1988). Control and A-chains in Modern Irish. *Natural Language and Linguistic Theory*, 6, 143-189.
- McDaniel, D. (1989). Partial and multiple wh-movement. *Natural Language and Linguistic Theory*, 7, 565-604.
- Moore, J. (1998). Turkish copy-raising and a chain locality. *Natural Language and Linguistic Theory* 16, 149-189.
- Morolong, M., & Hyman, L.M. (1977). Animacy, objects and clitics in Sesotho. *Studies in African Linguistics*, 8(3).
- Müller, G. (2004). Verb-second as vP-first. *Journal of Comparative Germanic Linguistics*, 7(3), 179-234.
- Müller, G., & Sternefeld, W. (1993). Improper movement and unambiguous binding. *Linguistic Inquiry*, 24(3), 461-507.
- Muriungi, Peter (2008). Phrasal movement inside Bantu verbs: Deriving affix scope and order in Kîîtharaka. PhD-thesis, University of Tromsø.

- Neelman, A., & Szendrői, K. (2008). Case morphology and radical pro-drop. In T. Biberauer (Ed.), *The limits of syntactic variation*. Amsterdam/Philadelphia: John Benjamins Publishing Company.
- Nevins, A. (2004). Derivations without the activity condition. In M. McGinnis & N. Richards (Eds.), *Proceedings of the EPP/Phase workshop*. Cambridge, Massachusetts: MIT, Department of Linguistics and Philosophy, MITWPL.
- Ntelitheos, D. (2002). *Possessor extraction in Greek and the left periphery of the DP*. Unpublished manuscript, University of California, Los Angeles.
- Obata, M., & Epstein, S.D. (2008). *Deducing improper movement from phase-based C-to-T phi transfer: Feature -Splitting internal merge*. Paper presented at the The 27th West Coast conference on formal linguistics, Sommerville, MA.
- Palmer, F. R. (1986). *Mood and modality*. Cambridge: Cambridge University Press.
- Perez (Harford), C. (1983). Locative pseudo-subjects in Shona. *Journal of African Languages and Linguistics*, 5, 131-155.
- Perez (Harford), C. (1985). *Aspects of complementation in three Bantu languages*. Unpublished PhD, University of Wisconsin-Madison.
- Perlmutter, D.M. (1972). Evidence for shadow pronouns in French relativization. In *The Chicago which hunt: Papers from relative clause festival*. Chicago: Chicago Linguistic Society.
- Pesetsky, D. (1997). Optimality theory and syntax: Movement and pronunciation. In D. Archangeli & D. T. Legendoen (Eds.), *Optimality theory: An overview* (pp. 134-170). Oxford: Blackwell.
- Pesetsky, D. (1998). Some optimality principles of sentence pronunciation. In P. Barbosa, D. Fox, P. Hagstrom, M. McGinnis & D. Pesetsky (Eds.), *Is the best good enough?* (pp. 337-383). Cambridge: MIT Press.
- Pesetsky, D., & Torrego, E. (2001). T-to-C movement: Causes and consequences. In M. Kenstowicz (Ed.), *Ken Hale: A life in Language*. Cambridge, Massachusetts: The MIT Press.
- Pesetsky, D., & Torrego, E. (2004). Tense, case, and the nature of syntactic categories. In J. Guéron & J. Lecarme (Eds.), *The syntax of time*. Cambridge, Massachusetts: The MIT Press.

- Polinsky, M., & Potsdam, E. (2006). Expanding the scope of control and raising. *Syntax* 9(2), 171-192.
- Postal, P. (1966). On so-called pronouns in English. In F. P. Dinneen (Ed.), *19th monograph on language and linguistics*. Washington, D.C.: Georgetown University Press.
- Postal, P.M. (1974). *On raising: One rule of English grammar and its theoretical implications*. Cambridge: MIT Press.
- Potsdam, E., & Runner, J.T. (2001). Richard returns: Copy raising and its implications. *Chicago Linguistic Society (CLS)* 37, 453-468.
- Pullum, G.k. (1975). On a non-argument for the cycle in Turkish. *Linguistic Inquiry*, 6, 494-501.
- Radford, A. (2004). *Minimalist syntax: Exploring the structure of English*. Cambridge: Cambridge University Press.
- Richards, M.C. (2007). On feature inheritance: An argument from the phase impenetrability condition. *Linguistic Inquiry*, 38(3), 563-572.
- Richards, M. D. (2004). *Object shift and scrambling in North and West Germanic: A case study in symmetrical syntax*. Unpublished Ph.D, University of Cambridge.
- Rivero, M.-L. (1991). Exceptional case marking effects in Rumanian. In D. Wanner & D. A. Kibbee (Eds.), *New analyses in Romance linguistics: selected papers from the xviii linguistic symposium on Romance languages* (pp. 273-298). Philadelphia: J. Benjamins Pub.
- Rizzi, L. (1982). *Issues in italian syntax*. Dordrecht: Foris.
- Rizzi, L. (1986). Null objects in Italian and the theory of pro. *Linguistic Inquiry*, 17, 501-557.
- Rizzi, L. (2000). *Comparative syntax and language acquisition*. London: Routledge.
- Rizzi, L. (2004). *On the form of chains: Criterial positions and ECP effects*. Unpublished manuscript, University of Siena.
- Rodrigues, C.A.N. (2004). *Impoverished morphology and A-movement out of case domains*. Unpublished Ph.D, University of Maryland, College Park.
- Rosenbaum, P. (1967). *The grammar of English predicate complement constructions*. Cambridge: MIT Press

- Roussou, A. (2001). Control and raising in and out of subjunctive complements In M.-L. Rivero & A. Ralli (Eds.), *Comparative syntax of Balkan languages* (pp. 74-104). Oxford: Oxford University Press.
- Runner, J.T. (2006). Lingering challenges to the raising-to-object and object-control constructions. *Syntax*, 9(2), 193-213.
- Saito, M. (1985). *Some asymmetries in Japanese and their theoretical implications*. Unpublished Ph.D, MIT, Cambridge, Massachusetts.
- Sells, P. (1984). *Syntax and semantics of resumptive pronouns*. Unpublished Doctoral dissertation, University of Massachusetts, Amherst.
- Şener, S. (2008). *Non-canonical case licensing is canonical: Accusative subjects of CPs in Turkish*. Unpublished manuscript, University of Connecticut.
- Sharvit, Y. (1999). Resumptive pronouns in relative clauses. *Natural Language and Linguistic Theory*, 17, 587-612.
- Shlonsky, U. R. (1992). Resumptive pronoun as a last resort. *Linguistic Inquiry*, 23, 443-468.
- Shlonsky, U.R. (1994). Agreement in COMP. *The Linguistic Review*, 11, 351-375.
- Shukla, S. (1981). *Bhojpuri grammar*. Washington, D.C.: Georgetown University Press.
- Soames, S., & Perlmutter, D.M. (1979). *Syntactic argumentation and the structure of English*. Berkeley, Los Angeles, California: University of California Press.
- Stowell, T. (1982). The tense of infinitives. *Linguistic Inquiry*, 13, 561-570.
- Stowell, T. (1983). Subjects across categories. *The Linguistic Review*, 2, 285-312.
- Stowell, T. (1989). Subjects, specifiers and X-bar theory. In M. Baltin & A. Kroch (Eds.), *Alternative concepts of phrase structure* (pp. 232-262). Chicago: University of Chicago Press.
- Stowell, T. (1991). Small clause restructuring. In R. Freidin (Ed.), *Principles and parameters in comparative grammar* (pp. 182-218). Cambridge, Mass.: MIT Press.
- Sulkala, H., & Karjalainen, M. (1992). *Finnish*. London, New York: Routledge.
- Svenonius, P. (2004). On the edge. In D. Adger, C. de Cat & G. Tsoulas (Eds.), *Peripheries: Syntactic edges and their effects* Dordrecht: Kluwer.
- Tanaka, H. (2002). Raising to object out of CP. *Linguistic Inquiry*, 33(4), 637-652.
- Terzi, A. (1997). PRO and null case in finite clauses. *The Linguistic Review*, 14, 335-360.

- Torrego, E. (1984). On inversion in Spanish and some of its effects. *Linguistic Inquiry*, 15(1), 103-129.
- Uchibori, A. (2000). *The syntax of subjunctive complements: Evidence from Japanese*. Unpublished Ph.D, University of Connecticut.
- Uchibori, A. (2001). Raising out of CP and C-T relations. In M. C. Cuervo, D. Harbour, K. Hiraiwa & S. Ishihara (Eds.), *Formal Approaches to Japanese Linguistics 3 (FAJL3): MIT Working Papers in Linguistics* (Vol. 41, pp. 145-162). Cambridge, Massachusetts: MIT Working Papers in Linguistics.
- Ura, H. (1994). Varieties of raising and their implications in the theory of case and agreement. In *MIT Occasional Papers in Linguistics* (Vol. 7). Massachusetts: MIT.
- Ura, H. (1998). Checking, economy and copy raising in Igbo. *Linguistic Analysis* 28, 67-88.
- Uriagereka, J. (1995). Aspects of the syntax of clitic placement in Western Romanian. *Linguistic Inquiry*, 26(1), 79-123.
- Vikner, S. (1994). Scandinavian object shift and West Germanic scrambling. In Corver, N. & Riemdijk, V. (Eds.), *Studies in scrambling: Movement and non-movement approaches to free word-order phenomenon* (pp. 487-517). Berlin: de Gruyter.
- Wager, J.S. (1983). *Complementation in Moroccan Arabic*. Unpublished PhD, MIT, Cambridge, Massachusetts.
- Watanabe, A. (1993). The notion of finite clauses in AGR-based case theory*. In J. D. Bobaljik & C. Phillips (Eds.), *MIT working papers in linguistics 18: Papers on case and agreement I* (Vol. 18, pp. 281-296). Cambridge, Massachusetts: MITWPL.
- Weiß, H. (2002). *Agr-in COMP and partial pro-drop*. Unpublished manuscript, Universität Regensburg.
- Williams, E. (1980). Predication. *Linguistic Inquiry*, 11, 203-308.
- Williams, E. (1983). Against small clauses. *Linguistic Inquiry*, 14, 287-308.
- Williams, E. (1986). *NP trace in theta theory*. Unpublished manuscript, University of Massachusetts, Amherst.
- Williams, E. (1994). *Thematic Structure in Syntax*. Cambridge, Massachusetts: MIT Press.

- Willis, D. (2000). On the distribution of resumptive pronouns and Wh-traces in Welsh. *Journal of Linguistics*, 36, 531-573.
- Yadava, Y.P. (1989). Raising from a tensed clause in Maithili: Its implication for binding and case theory. *Contributions to Nepalese Studies*, 16(1), 1-9.
- Yoon, J.-M. (1991). *The syntax of A-chains*. Unpublished Ph.D, Cornell University.
- Yoon, J. (1996). Ambiguity of government and the chain condition. *Natural Language and Linguistic Theory*, 14(1), 105-162.
- Zaenen, A., Engdahl, E., & Maling, J.M. (1981). Resumptive pronouns can be syntactically bound. *Linguistic Inquiry*, 12, 679-682.
- Zeller, J. (2006a). Raising out of finite clauses in Nguni: The case of *fanele* Southern African Linguistics and Applied Language Studies 24(3), 255-275.
- Zeller, J. (2006b). *Raising out of finite clauses and expletive constructions in Zulu*. Unpublished manuscript, University of KwaZulu-Natal, Durban.
- Zeller, J. (2006c). Agreement and the EPP in Kinyarwanda applicatives. In P. Brandt & E. Fuß (Eds.), *Form, structure and grammar* (pp. 275-295). Berlin: Akademie-Verlag.
- Zeller, J. (2006d). On raising out of finite clauses in Nguni. Paper presented at the Annual LSSA/SAALA-conference 2006, Durban, 6 July 2006.
- Zeller, J. (2009). 'On clitic left dislocation in Zulu'. *Frankfurt African Studies Bulletin* 18 (2006), 131-156.
- Zwart, C.J. (1993). Clues from dialect syntax: Complementiser agreement. In W. Abraham & J. Bayer (Eds.), *Dialektsyntax: Linguistische Berichte Sonderheft 5* (pp. 246-270). Opladen: Westdeutscher Verlag.
- Zwart, C.J. (1997). *Morphosyntax of verb movement*. Dordrecht: Kluwer.