

Scrambling in Afrikaans

by

F.W Louw

(205510981)

Coursework dissertation submitted in partial fulfillment of the requirements for a degree of Master of Arts in Linguistics in the school of Language Literature and Linguistics, University of KwaZulu-Natal, Durban 2012.

COLLEGE OF HUMANITIES

DECLARATION - PLAGIARISM

I, **Frederik Wilhelm Louw** declare that

1. The research reported in this thesis, except where otherwise indicated, is my original research.
2. This thesis has not been submitted for any degree or examination at any other university.
3. This thesis does not contain other persons' data, pictures, graphs or other information, unless specifically acknowledged as being sourced from other persons.
4. This thesis does not contain other persons' writing, unless specifically acknowledged as being sourced from other researchers. Where other written sources have been quoted, then:
 - a. Their words have been re-written but the general information attributed to them has been referenced
 - b. Where their exact words have been used, then their writing has been placed in italics and inside quotation marks, and referenced.
5. This thesis does not contain text, graphics or tables copied and pasted from the Internet, unless specifically acknowledged, and the source being detailed in the thesis and in the References sections.

Signed

.....

F.W Louw

Acknowledgements

I am grateful for the 2012 Postgraduate grant awarded to me by the College of Humanities in the School of Arts. I'd like to thank the Linguistics department and my supervisor Professor Jochen Zeller for their support. I am also thankful for the feedback I received presenting at the 2011 Linguistics Society of South Africa (LSSA) 'Interactions and Interfaces' conference. Thank you to the following friends and family members who had to listen to and judge many scrambled sentences: Adri, Jana, Louise, Maggi, Estelle, Lerushca. I'd also like to extend a special thanks to Daniel, and to Julia.

Abstract

'Scrambling' languages allow arguments in a given sentence to be ordered in a variety of ways while leaving the grammatical roles of these arguments unchanged. West Germanic languages like German, Dutch, Yiddish, and West Flemish exhibit, to different extents, scrambling properties (Haider, 2006; Grewendorf, 2005; De Hoop, 2003). One well established assumption is that a prerequisite for scrambling is a rich (overt) case morphology: Grammatical relations need to be overtly marked on arguments in order for them to freely permute (Haider, 2006; Mahajan, 2003). Afrikaans, like other West Germanic languages, also allows a certain degree of flexibility (Molnárfi, 2002; Biberauer & Richards 2006; Conradie, 2007 Huddleston, 2010). Generally, however, it is assumed to be much more rigid than a richly inflected language like German, in part because Afrikaans is the most morphologically 'impoverished' of all the West Germanic languages (Molnárfi, 2002; Biberauer & Richards, 2006; Huddleston, 2010). In this thesis, I draw attention to certain double object constructions in Afrikaans that allow German-like flexibility without German-like morphology. Afrikaans allows the indirect and direct object of particular verbs to optionally invert their canonical order in finite embedded sentences without V-raising. I propose an analysis within a minimalist framework that accounts for the flexibility exhibited by these constructions.

Contents

Acknowledgements	3
Abstract	4
List of abbreviations	7
Chapter 1: Introduction	8
Chapter 2: Theory	11
1. Minimalist Syntax:	11
1.1. The computational system	12
1.2. The derivation	13
1.3. Economy considerations	16
2. West Germanic.....	17
2.1. General characteristics	17
2.2. Phrase structure	23
2.3. The Middlefield	22
2.4. Afrikaans.....	24
3. Conclusion.....	27
Chapter 3: Scrambling	28
1. What is scrambling?	28
2. Types of scrambling	31
2.1. Clause-internal scrambling	31
2.1.1. Short-distance scrambling.....	31
2.1.2. Medium-distance scrambling.....	35
2.2. Clause-external scrambling	38
2.3. Summary	40
3. Grammatical effects of scrambling	41
3.1. A/A' movement	41
3.2. Binding.....	43
3.3. Scope and reconstruction	44
3.4. Discourse and semantic effects of scrambling.....	45
3.5. Grammatical prerequisites for scrambling.....	48
4. Conclusion.....	50
Chapter 4: Scrambling and Afrikaans	51
1. Double object constructions.....	52
1.1. The Dative: PP-DOCs.....	52
1.2. The Double Object Construction: DOCs	53
1.2.1. Rigid DOCs	53

1.2.2. Flexible DOCs	55
1.3. Scrambling conditions.....	58
1.3.1. Sentence format.....	58
1.3.2. Verbs.....	61
2. Analysis	63
2.1. Core-arguments.....	63
2.2. The syntax of DOCs.....	66
2.2.1. Rigid DOCs	68
2.2.2. Flexible DOCs	69
2.3. Applicatives.....	74
3. Conclusion.....	78
Chapter 5: Conclusion	80
Bibliography	85

List of abbreviations

ADV	Adverb
CI	Conceptual-Intentional System
DO	Direct Object
DOC	Double Object Construction
FL	Faculty of Language
FLB	Faculty of Language in the broad sense
FLN	Faculty of Language in the narrow sense
IO	Indirect Object
LB	Left Bracket
LF	Logical Form
MP	The Minimalist Program
MSc	Mainland-Scandinavian
NF	Nachfeld (Post-field)
OBJ	Object
OV	Object>>Verb
P&P	Principles and Parameters
PF	Phonological Form
PLD	Primary Linguistic Data
Prt	Particle
RB	Right Bracket
SM	Sensory-Motor System
SUB	Subject
UG	Universal Grammar
V	Verb
V_{AUX}	Auxiliary Verb
Vc	Verb Complex
VF	Vorfeld (Pre-field)
VO	Verb>>Object
WCO	Weak cross-over effect

Chapter 1

Introduction

'Scrambling' languages allow arguments in a given sentence to be ordered in a variety of ways while leaving the grammatical roles of these arguments unchanged. West Germanic languages like German, Dutch, Yiddish, and West Flemish exhibit, to different extents, scrambling properties (Haider, 2006; Grewendorf, 2005; De Hoop, 2003). One well established assumption is that a prerequisite for scrambling is a rich (overt) case morphology: Grammatical relations need to be overtly marked on arguments in order for them to freely permute (Haider, 2006; Mahajan, 2003).

Afrikaans, like other West Germanic languages, also allows a certain degree of flexibility (Molnárfi, 2002; Biberauer & Richards, 2006; Conradie, 2007; Huddleston, 2010). Generally, however, it is assumed to be much more rigid than a richly inflected language like German, in part because Afrikaans is the most morphologically 'impoverished' of all the West Germanic languages (Molnárfi, 2002; Biberauer & Richards, 2006; Huddleston, 2010). In this thesis, I draw attention to certain sentences in Afrikaans that allow German-like flexibility without German-like morphology (i.e. sentences that allow permutation of the canonical hierarchy of arguments). To my knowledge these Afrikaans constructions remain unstudied. The absence of an analysis of 'scrambling' in Afrikaans therefore constitutes an important gap in the literature. The aims of my project are to (1) contribute original empirical research on Afrikaans scrambling to the field, (2) place these findings in context, against a rich body of work done on other West Germanic languages, and (3) analyze these findings with the tools developed by modern syntactic theory.

In Chapter 2 I discuss the theoretical background against which the problem of scrambling is framed, and introduce the basic grammatical properties of Afrikaans. I introduce some core concepts and ideas underlying minimalist syntax, including the architecture of the human language faculty, the working of the syntactic computational system and its interfaces, and the way a derivation is assumed to proceed in this

framework. It is against this backdrop that the optionality of scrambling is seen as a puzzle for minimalist syntax which assumes that movement is associated with strong morphological features.

In Chapter 3 I discuss scrambling as a movement operation. I distinguish different types of scrambling, grammatical effects associated with scrambling, and the attested preconditions for a scrambling grammar. Chapter 3 develops descriptive categories for different instances of scrambling which I use to identify instances of scrambling in Afrikaans.

In Chapter 4 I discuss the double object construction in Afrikaans. One type of double object construction in Afrikaans requires a rigid argument hierarchy (subject >> indirect object >> direct object) in order to identify *who* did *what* to *whom* (i.e. to establish case relations). I refer to these double object constructions as 'Rigid DOCs'. Another type of double object construction in Afrikaans shows a free-ordering characteristic not expected to be possible in an Afrikaans-like grammar. I refer to these constructions as 'Flexible DOCs'. Flexible DOCs allow object arguments to optionally alter their canonical argument hierarchy of the sentence while still maintaining the grammatical relations between arguments as they apply in the canonical order. This is possible in Afrikaans despite the fact that Afrikaans has virtually no overt morphological case marking. I observe that Afrikaans scrambling is associated with, and limited to, specific types of verbs. I propose a syntactic analysis of these particular constructions by contrasting double object constructions that can scramble and double object constructions that cannot scramble. I identify these types as having distinct syntactic structures. I propose that double object constructions are always associated with a functional head 'F' that always selects VP. F has an EPP feature that requires a category in [Spec, F]. Rigid DOCs involve a non-core argument that is introduced by F in [Spec, F]. Rigid DOCs always generate the indirect object higher in the sentence than the direct object, which explains its rigid ordering restrictions. Flexible DOCs involve two VP-internal core-arguments. I propose that the VP-internal core-arguments are equidistant from F as the objects occupy the same minimal domain. I argue that either object can move to [Spec, F] to satisfy F's EPP feature at the same 'cost' and hence both the canonical order

(indirect object>>direct object) and non-canonical order (direct object>>Indirect object) are permitted.

Chapter 5 concludes, providing a brief summary of the argument, the main contributions of the thesis, and topics for future research.

Chapter 2

Theory

In this chapter I provide a brief introduction to some core ideas underlying minimalist syntax (section 1), I discuss movement in a minimalist system (section 2), and, lastly, I discuss the relevant assumptions and challenges involved in treating Afrikaans and scrambling in a minimalist system (section 3).

1. Minimalist syntax

A minimalist conception of language assumes that all healthy humans are born with an innate Faculty of Language (FL) that is highly sensitive to linguistic information (Chomsky, 1995: 14). FL includes a base of universal principles (i.e. a Universal Grammar (UG)) within which language acquisition proceeds (see Hornstein, Nunes & Grohmann, 2005: 2-7). A child is able to rapidly (re)construct a particular grammar by using the bits and pieces of linguistic data (i.e. the ‘primary linguistic data’ (PLD)) in its immediate environment as input. A particular grammar, or I(nternal)-language, is an attained state of FL (Chomsky, 1995: 14)¹. An I-language’s particular form is determined by the presence/absence of specific grammatical features in the PLD (Epstein & Thráinsson, 1996: 2-3). Cross-linguistic variation (i.e. structural/syntactic variation between different languages) is partially approached as differences in FLs grammatical “settings” (at UG). It is assumed that the forms of attainable states possible within UG are highly restricted and that these forms diverge along predictable lines. The universal principles made available by UG, in other words, may be set in a finite number of ways (perhaps only two), which give rise to the specific way a particular grammar works (Chomsky, 1995: 25). For example: The universal principle that phrases have heads can be parameterized in the phrase structure of a language as either head-first or head-

¹ It is important not to conflate ‘a language’ (in the general sense: English, Zulu, French, etc.) with an ‘I-language’ (individual/internal-grammar). The study of an I-language deals with a particular language as a state of a particular speaker’s FL, and Chomsky (1995) reminds the reader that a language community is approached “only derivatively” as a collection of similar I-languages (pg. 15).

final (i.e. a 'directionality parameter'). The heads of English VPs, for example, are set 'head-first' (1) while those of Japanese VPs are parameterized as 'head-final' (2) (Hornstein et al., 2005: 218). This approach is broadly referred to as the theory of Principles and Parameters (P&P) (Chomsky, 1981; Chomsky & Lasnik, 1993; Chomsky, 1995).

(1) *English*

John [VP ate sushi]
 V Compl

(2) *Japanese*

Jiro-ga [VP sushi-o tabeta]
 Jiro-NOM sushi-ACC ate
 Compl V
 "Jiro ate sushi"

The Minimalist Program (MP) is a generative approach to the formal study of language (Chomsky, 1993; 1995; 2000, 2001, 2008). MP embodies a set of economy/parsimony principles pertaining to, firstly, the architecture of FL and the operation of its computational system, and, secondly, the adequacy and parsimony of theoretical accounts (Epstein & Thráinsson, 1996: 4). MP explores the question of "to what extent does language approximate an optimal solution to conditions that it must satisfy to be usable at all, given extra-linguistic structural architecture?" (Chomsky, 2005: 9). I sketch some of the main 'minimalist' ideas I will adopt in this thesis below. I work within a framework drawing mostly from Chomsky (1995) and Chomsky (2000).

1.1. The computational system

Hauser, Chomsky & Fitch (2002) distinguish between FL in the broad sense (FLB) and FL in the narrow sense (FLN) (pg 1569). FLB includes all that is required for language acquisition and language use and must therefore involve a sensory-motor system (SM), and a conceptual-intentional system (CI), as well as a computational mechanism for building sentences (ibid). Hauser et al. (2002) argue that the computational mechanism for recursion (i.e. FLN) is at the core of human language's unique 'discrete infinity' (pg.

1573). Human language allows an unbounded set of sentences using a finite set of words. FLN², at a minimum, includes (1) (access to) a lexicon where lexical and functional items are stored, and (2) a computational mechanism for building syntactic objects from items in the lexicon (Chomsky, 1995: 33). FLN must involve a way of relating syntactic objects to the external performance systems, SM and CI. This is done through the interfaces 'Phonological Form' (PF) and 'Logical Form' (LF) (Chomsky, 1995: 21). PF is the interface with the mechanisms of production and perception (SM), and LF is the interface with the interpretational system of semantics (CI) (see Chomsky, 1995: 21-30). The strong minimalist thesis holds that FLN is "an optimal solution to legibility conditions", and relates information to the external performance systems in a maximally efficient way (Chomsky, 2000: 96).

1.2. The derivation

The lexicon includes substantive and functional items (Chomsky, 2000: 102). Lexical items consist of semantic- (interpretable only at LF), phonological- (interpretable only at PF), and syntactic/formal features (relevant only to the computational system) (Epstein & Thráinsson, 1996: 8). The formal features of lexical items consist of categorical features (e.g. N(oun), V(erb), A(djective), etc.), case features (nom(inative), acc(usative), etc.), and φ -features (i.e. person, number, gender) (Epstein & Thráinsson, 1996: 9). I assume that all substantive items enter the derivation with valued formal features.

Functional items (i.e. C(omplementizer), T(ense), litte v, D(eterminer)) enter the derivation with their formal features either valued or unvalued (Collins, 1997: 21). Unvalued formal features need to be valued in the course of the derivation in order to ensure that the derivation does not crash at the interfaces (Chomsky, 1995: 171).

Unvalued features on a functional item's head are valued by the operation Agree. Agree establishes a matching relation between the functional head's unvalued feature (the

² I use 'FLN' to refer to the syntactic component of FL.

‘Probe’) and the closest corresponding³ feature on a suitable element in its (c-command) domain (the ‘Goal’) and eliminates/checks the unvalued feature, if possible, in this way (Chomsky, 2000: 122). ‘Closeness’ is understood in terms of c-command (3) and (4). In (4) Y is *closer* to X than Z iff X c-commands Y and Y c-commands Z (where ‘>>’ represents c-command).

(3) C-command:

α c-commands β if α does not dominate β and every γ that dominates α dominates β

(4) $X \gg Y \gg Z$

If the head hosting the Probe has a strong syntactic feature, e.g. an EPP feature on T, the closest suitable DP (object) must also move overtly into a local structural configuration (a specifier-head relation) with the functional head where it must be phonologically realized (Chomsky, 1995: 232). If no strong feature is present, the DP does not move and is phonologically realized *in situ*. Word-order variation across languages can be elegantly accounted for in terms of the (parameterized) distribution of functional items and presence/absence of strong/weak syntactic features on these items (Chomsky, 1995: 54; 131). One example is the V2 property. In contrast to a language like English which does not have V2, Afrikaans has a strong set of features on C which forces V2 in main clause declaratives (see section 2). Another example is overt *wh*-movement in interrogatives: English has it, but a language like Hindi does not (Mahajan, 1990: 20). The strong/weak distinction (at least for phrasal movement) is now captured in terms of an EPP feature (i.e. a strong D-feature) on functional heads T, C, and v (Chomsky, 2000). Only functional elements may be associated with strong categorical features. T arguably always has an EPP feature while C and v optionally host an EPP feature (Chomsky, 2000: 102). The EPP feature is an unvalued formal feature that requires that the head hosting this feature must have a subject, i.e. a suitable element in its specifier position, forcing overt movement on a suitable (usually phrasal) element (ibid).

³ That is to say a phrase containing the relevant *valued* features.

A syntactic object is built by successively merging a set of items drawn from the lexicon. The set of items drawn from the lexicon is referred to as a 'Numeration' and the items in the Numeration are the only items the computation has access to (Collins, 1997: 2; Chomsky, 1995: 189). There are two sub-cases of the operation Merge. Given a syntactic object A, an independent element B (which may itself be complex) is merged with A (see (5), with A = XP and B = WP). Alternatively, B can be chosen from the derivation built *thus far* and Merge with A (see (6) with A = XP and B = WP). The first case is referred to as External Merge (or just 'Merge') (5) and the second case is referred to as Internal Merge (or 'Move') (6).

(5) *External Merge*

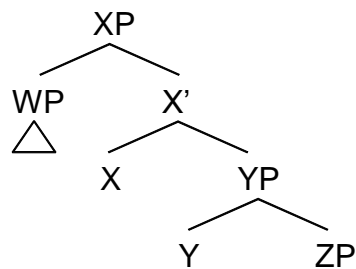

(6) *Internal Merge*

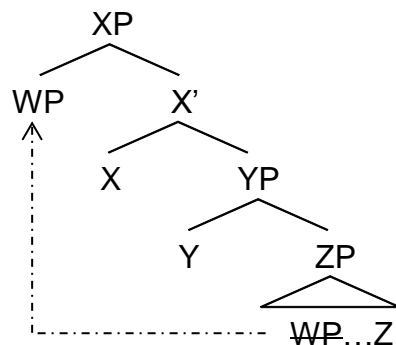

External Merge establishes base positions ('first merge'), while Internal Merge establishes derived positions. Base positions are associated with θ -role assignment which occurs in the 'internal domain' (also referred to as the 'lexical domain') of the sentence (i.e. VP for internal arguments and vP for the external argument(s))

(Chomsky, 1995: 312-313). Derived positions are strictly for feature-checking and occur outside the internal domain in the functional domain (i.e. VP-externally) (ibid). I adopt the basic functional structure represented in (7). I also adopt the VP-shell hypothesis (schematically represented in (8)) where VP contains internal arguments and the verb's external argument(s) is introduced by a phonologically null light verb (v) (Chomsky, 1995: 315). Given the presence of multiple arguments, V (or some other lexical category) assigns θ -roles to the internal argument inside VP, while v assigns a θ -role to the external argument. The vP and VP, in this way (I oversimplify) are seen as constituting a complex predicate (Hornstein et al., 2005: 98; Chomsky, 1995: 316; 352).

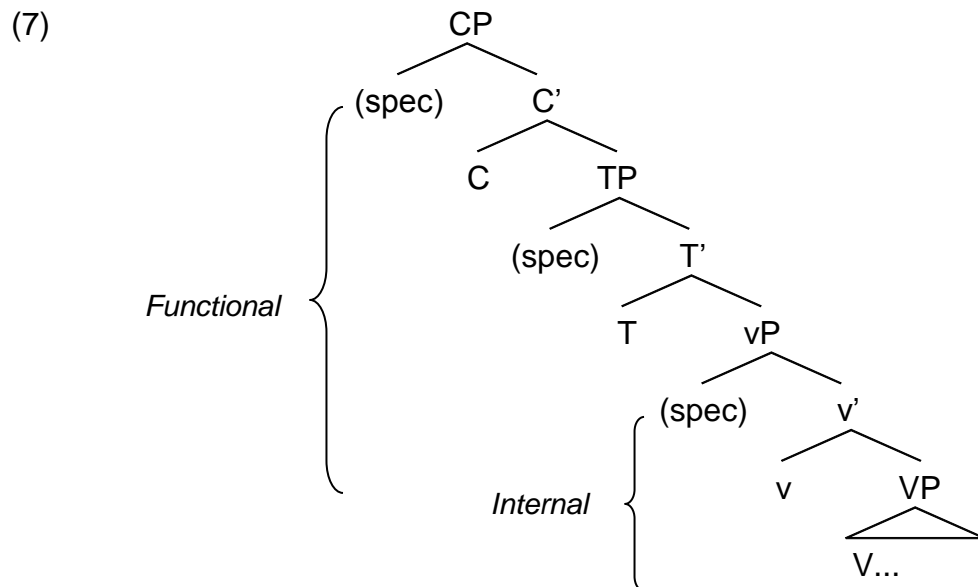

(8) $[_{VP} [_{\text{External argument}}] [_{v'} [v] [_{VP} [_{\text{Direct object}}] [_{V'} [V] [_{\text{Indirect object}}]]]]]$
 AGENT THEME GOAL

1.3. Economy conditions

The derivation in a minimalist approach is assumed to be governed by certain economy conditions. Economy conditions essentially boil down to the following: 'Cheaper' operations are preferred over more 'costly' operations, where cost is determined by (1) Complexity, (a) locally (at given points in the derivation), and (b) globally (overall), and (2) Necessity. Shorter movement (i.e. shorter movement chains) is preferred over

longer movement (Chomsky, 1995: 295). Movement does not occur when it does not have to (e.g. when Agree can resolve unvalued features without the need for movement). Movement is considered a 'costly' operation, and must only occur as a last resort (Chomsky, 1995: 253). Furthermore, Agree and Move must always select the closest suitable argument in the Probe's c-command domain. Derivations that do not select the closest available argument are ruled out (Epstein & Thráinsson, 1996: 16). The economy conditions are meant to rule out unnecessary elements and unnecessary steps in the derivation (Chomsky, 1995: 130; Chomsky, 2000: 99). If FLN approaches an optimal system and is assumed to be a 'perfect' way of relating information to the external performance systems, inefficient operations (in the sense of being unmotivated or unnecessary) should not be expected. It is assumed in this thesis that the derivation is characterized as a 'least effort' process (Chomsky, 1995: 161).

2. West Germanic

2.1. General characteristics

The context for discussion in this thesis is a set of West Germanic languages: High German (of Germany and Austria), Dutch (of the Netherlands and Belgium), and Afrikaans (of South Africa) (Zwart, 2005: 903). These languages share a set of syntactic characteristics: (1) A verb-placement asymmetry in main and embedded clauses (also referred to as the "matrix-embedded asymmetry"), (2) Sentence-final verbal clusters in embedded clauses, (3) A verb in clause second position in main clauses (referred to as 'V2'), (4) Post-verbal extraposition of complement clauses, and (4) Scrambling (Zwart, 2005: 904-905; Hinterhölzl, 2006: 6-13). Scrambling is discussed in Chapter 3 and 4.

The first four characteristics of West Germanic are illustrated by the Dutch examples in (9) (all from Zwart, 2005: 905). Examples (9a) and (9b) show that, within a main clause, the verb (V), *kust* ('kissed') in this case, is in second position (V2) with the object (OBJ) *Marie* ('Mary') following it. In the embedded clause (9b) the verb is in sentence-final position with the object preceding it (OV). Example (9c) illustrates the clause-final

position of a verbal ‘cluster’ in an embedded sentence consisting of the finite and two non-finite verbs (VVV), *zou willen kussen* (‘would want kiss’). Example (9d) illustrates V2 with a *wh*-phrase, *waarom* (‘why’), occupying sentence-initial position, and the verb, *kust* (‘kiss’), following it (I discuss V2 in greater detail shortly). Example (9e) illustrates the right-dislocated position of the complement clause *dat hije Marie kuste* (‘that he Mary kisses’).

(9) Dutch

- a. Jan kust Marie
John kisses Marie
SUB V OBJ
“John kisses Marie”

- b. dat Jan Marie kust
that John Mary kisses
C SUB OBJ V
“...that John kisses Mary”

- c. dat Jan Marie zou willen kussen
that John Mary would want kiss
C SUB OBJ V V V
“...that John would like to kiss Mary”

- d. Waarom kust Jan Marie?
Why kisses John Marie?
V SUB OBJ
“Why does John kiss Mary?”

- e. dat Jan niet wist [dat hije\ Marie kuste]
that John not know [that he Mary kissed]
V CP
“...that John does not know that he kisses Mary”

(Zwart, 2005: 905)

V2 is a requirement that the finite verb appears in the position immediately following a sentence initial topic. The topic is usually phrasal and can be a subject (10a), an adverbial (10b), an object (10c), a *wh*-element (10d), a prepositional phrase (10e), etc. (Biberauer 2001:19). In example (10a) the SUB *André* is the sentence initial phrase, in example (10b) the temporal ADV *gister* (‘yesterday’) is the sentence initial phrase, in

example (10c) the OBJ *die storie* ('the story') is the sentence initial phrase, in example (10d) the *wh*-OBJ *wat* ('what') is in sentence initial position, and in example (10e) the PP *op die stoel* ('on the chair') occupies the sentence initial position.

(10) *Afrikaans*

- a. André het gister die storie geskryf
 André has yesterday the story written
 SUB V_{AUX} ADV OBJ V
 "André wrote the story yesterday"
- b. Gister het André die storie geskryf
 Yesterday has André the story written
 ADV V_{AUX} SUB OBJ V
- c. Die storie het André gister geskryf
 The story has André yesterday written
 OBJ V_{AUX} SUB ADV V
- d. Wat lees jy vandag?
 What read you today
 OBJ V SUB ADV
 "What are you reading today"
- e. Op die stoel het hy die boek gesit
 On the chair has he the book put
 PP V_{AUX} SUB OBJ V
 "He put the book on the chair"

(Biberauer 2001:19)

V2 is limited to main clauses in West Germanic. As mentioned above the verb-placement asymmetry in West Germanic is that main clauses typically exhibit an SVO order while embedded clauses are typically SOV.

The V2 property of West Germanic languages can be accounted for straightforwardly in the following way (but see Vikner, 1995): Main clauses require a (finite) V in [Spec, C]. Let it be assumed then that C has a strong unvalued [V] feature and a [Topic/EPP] feature requiring that the C-position be filled by a V and that [Spec, C] be filled by a suitable topic (DP, PP, ADV, etc.). In main clauses the [V] on C is satisfied by adjoining V_{AUX} to C if there is a V_{AUX} in T-position by T-to-C movement, or, if there is no V_{AUX}, by

moving V to the T-position and then to the C-position. The [Topic/EPP] feature on C is checked by moving a suitable topic into [Spec, C] (overt movement is forced by the EPP). The process accounts for the word order in main clauses. In embedded clauses with an overt C, V2 is blocked and there is no requirement to fill [Spec, C].

2.2. Phrase structure

I adopt the following basic SOV structure (11) for West Germanic:

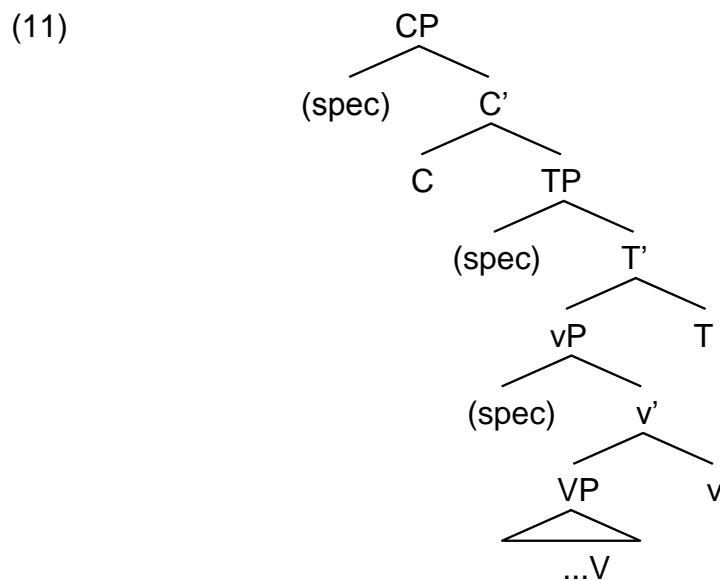

An finite declarative Afrikaans sentence like (12) proceeds as is represented in (13) with three movement operations: (1) After vP is constructed, the SUB *die man* ('the man') raises to [Spec, T] to satisfy the EPP feature on T, (2) T raises to C to satisfy the strong [V] feature on C, and (3) the ADV *gister* ('yesterday') raises to [Spec, C] to satisfy the EPP feature on C. I assume that θ -roles are assigned within VP and vP (as discussed in section 1.2). In this example the DO *die boek* ('the book') receives its θ -role from V, and the SUB *die man* ('the man') receives its θ -role in [Spec, v]. I will assume that structural case of the object can be checked (under Agree) by v ([accusative]) within vP, and the structural case of the subject can be checked by T ([nominative]) within TP.

(12) *Afrikaans*

Gister het die man die boek gelees
 yesterday has the man the book read
 “The man read the book yesterday”

(13)

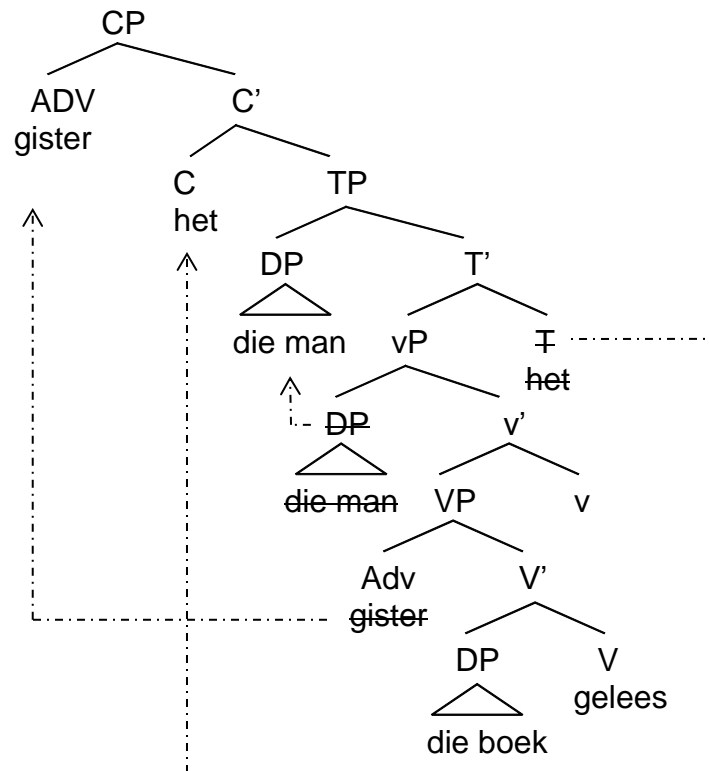

In the case of an embedded ditransitive sentence like (14) with an overt C-element, V2 is blocked. Example (15) represents the phrase structure of a ditransitive sentence like (14). In the internal domain, θ -roles are assigned by V to the internal arguments, the IO *die vrou* ('the woman'), and the DO *die boek* ('the book'). The external argument, the SUB *die man* ('the man'), receives its θ -role from v. In a sentence like (14) there is a problem that arises with the presence of three arguments and structural case checking (Stroik, 1996: 35-36). T is able to check the SUB's structural case, but I will assume that in a ditransitive sentence there are two options for object case checking: Either the IO can be assigned inherent case by the verb (Chomsky, 1995: 114), or a second light

verb is associated with double object constructions and one object argument can check structural case against this head (I explore the latter option in chapter 4) (see Anagnostopoulou, 2001: 3,4). Lastly, the external argument SUB *die man* ('the man') moves to [Spec, T] to satisfy the EPP feature on T.

- (14) ...dat die man die vrou die boek gegee het
 ...that the man the woman the book given has
 "that the man gave the book to the woman"

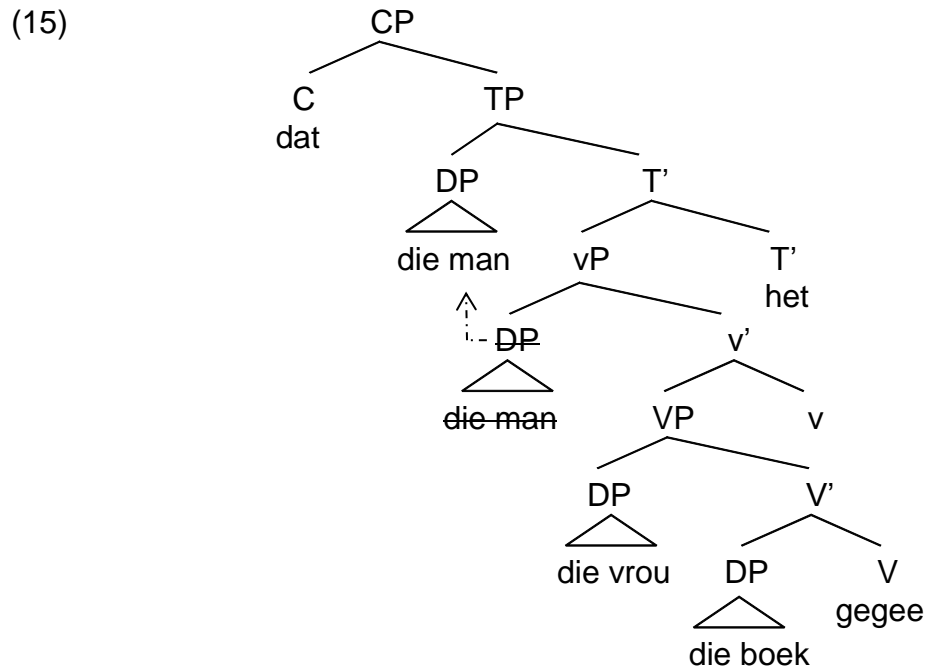

I will assume that West Germanic languages have the heads of TP, vP, and VP on the right. Minimalist syntax sometimes adopts a Universal Base Hypothesis (UBH). A UBH assumes a universal VO-base order (Kayne, 1994; for Dutch see Zwart, 1993). The OV/VO distinction, under such an assumption, can be captured as a result of movement rather than in terms of a cross-linguistic head-parameter (Mahajan: 2003: 218). An OV surface order is thus derived from a VO base order by moving the verb's inner argument leftward over the verb (for linearization purposes) (Mahajan: 2003). Cross-linguistic differences in surface order can be accounted for in terms of the presence or absence

of a triggering feature in the derivation, i.e. OV languages have it and VO languages do not. I opt for a head-parameter distinction and assume that in West Germanic (at least, in German, Afrikaans, and Dutch) the phrase structure corresponds to (8) (but for an SVO treatment of Afrikaans see Biberauer, 2001; Botha & Oosthuizen, 2009).

2.3. The Middlefield

This thesis will be interested in the word-order variation that occurs in a specific segment of West Germanic sentence structure referred to as the *Mittelfeld* (MF). I adopt a familiar (simplified) topology, in order to informally refer to segments of relevant sentences (see Drach, 1937; Höhle, 1986). The sentence is divided, roughly, into five segments: Pre-field (Vorfeld) >> left sentence bracket (LB) >> midfield (Mittelfeld) >> right sentence bracket (RB) >> post-field (Nachfeld). The MF is between the LB and the RB (Haider, 2006: 205) (16).

(16) VF... LB[...MF...]RB NF...

If it is assumed that the LB corresponds to the C-position, and that RB corresponds to the base position of the verb, then the MF constitutes the segment between these elements (Haider, 2006: 205). I illustrate the sentence segments in relation to phrase structure below in (17). Of course these segments do not correspond to exact syntactic positions. In main clauses C is occupied by V_{AUX} or V (if there is no V_{AUX}), i.e. LB is the V2 position, and V is occupied by the main verb (if there is a V_{AUX}) or the copy of V. In the embedded context C is occupied by an overt complementizer (i.e. LB is an overt C), and V represents the sentence-final Verb-complex. VF represents the sentence-initial position and is the landing site for left-dislocated elements (focused/topicalized elements) while NF represents the post verbal domain and is the landing site for right-dislocated elements.

(17)

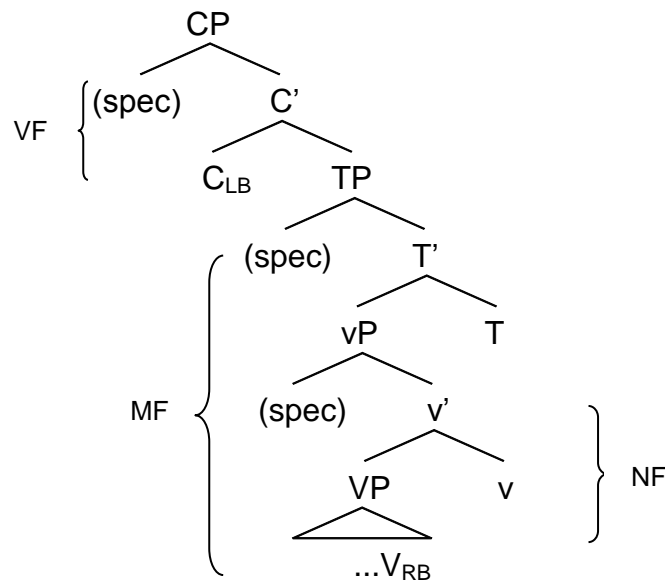

2.4. Afrikaans

The specific focus of this thesis is on Afrikaans. Afrikaans originated from 17th century Dutch but has developed into a distinct language within South Africa (Donaldson, 1993). It is spoken almost entirely in South Africa (but there are also groups of speakers in Namibia and in other areas in the Southern African region). Afrikaans is recognized as one of South Africa's 11 official languages. Afrikaans has a very limited case-morphology and has lost virtually all the inflectional morphology associated with its parent language Dutch (Ponelis, 1979: 19; Biberauer, 2001: 20-21; Huddleston, 2010: 25).

Afrikaans does not distinguish case or gender in its nominal system except for personal pronouns that inflect for case (SUB, and OBJ) and person (1st, 2nd, 3rd), as shown in the table below (taken from Huddleston, 2010: 25) (18).

(18)

	SUB	OBJ	Plural
1 st person	ek ('i')	my ('me')	ons ('us')
2 nd person	jy ('you')	jou ('you')	julle ('you')
3 rd person	hy/sy/dit ('he/she/it')	hom/haar/dit ('him/her/it')	

Direct and indirect objects can be accompanied by an (optional) prepositional marker like *vir* ('to'/'for') or *aan* ('to'). In example (19a) the DO *Piet* ('Peter') can be optionally marked by the preposition *vir* ('for'), in example (19b) the IO *die man* ('the man') can be optionally marked by the preposition *vir* ('for'). The preposition is sometimes obligatory (or strongly preferred) for grammaticality, the preposition *vir* ('for') is also generally restricted to [+animate] objects. In example (20a) IO *hom* ('him') is ungrammatical without the preposition *aan* ('to'), and in example (20b) the DO *Piet* ('Peter') requires the addition of the preposition *vir* ('for') for acceptability. The examples below illustrate how the DO and IO can be distinguished by inflection, or the addition of a preposition to the IO object. In double object sentences there is a strong preference for the prepositional marker on IO objects, specifically when the IO is in a non-canonical position. Double object constructions have a SUB>>IO>>DO canonical order. However, a prepositional marker is not always necessary. In the absence of prepositional markers there is often a strong reliance on word order to distinguish *who* did *what* to *whom* (SUB>>IO>>DO).

(19) *Afrikaans*

- a. Hulle het (vir) Piet geslaan
They have for Peter beaten
SUB DO
"They beat Peter up" (Den Besten, 2000: 950)

- b. Ek het (vir) die man die boek gelees
 I have to the man the boek read
 SUB IO DO
 "I read the book to the man"

(20) Afrikaans

- a. Ek het 'n foonkie *(aan) hom gegee
 I have a tip to him given
 SUB DO IO
 "I gave him a tip" (De Stadler, 1996: 254)

- b. Ek het nie ??(vir) Piet gesien nie
 I have not for Peter seen not
 SUB DO
 "I did not see Peter" (Den Besten, 2000: 950)

Afrikaans only inflects a limited number of verbal elements for tense (most of which I indicate in the table below (21)). Afrikaans only inflects the infinitive *hê* ('have'), some modal verbs (21c)-(21g), the copula *is* ('is') (21b). Afrikaans also inflects with the past-tense marking prefix *ge-* (21a)-(21b) which is always used with auxiliaries like *het* ('has') or *word* ('be').

(21)

	Present Tense	Past Tense	Past+ participle	Infinitive
a.	het ('has')	had ('had')	gehad	hê ('to have')
b.	is ('is')	was ('was')	gewees	wees ('to be')
c.	kan ('can')	kon ('could')		
d.	mag ('may')	mog ('might') [archaic]		
e.	moet ('must')	moes ('must')		
f.	sal ('will')	sou ('should')		

g.	wil ('want')	wou ('wanted')		
----	--------------	----------------	--	--

(Ponelis, 1979: 190)

Tense can also be indicated by employing a temporal adverb like *gister* ('yesterday') or *vandag* ('today') with an unmarked verb (22a), or by using an inflected modal verb with unmarked verb (22b) (Huddlestone, 2010: 27). Otherwise there is no overt present tense/infinitive distinction on verb forms. Afrikaans does not have person, gender or number agreement on these elements (Biberauer, 2001: 21).

- (22) a. Gister koop Jan die boek.
 Yesterday buy John the book
 "Yesterday, Jan bought the book"
- b. Jan kon die boek koop.
 Jan could the book buy
 "Jan was able to buy the book."

(Huddlestone, 2010: 27).

3. Conclusion

I have attempted to sketch some of the main ideas my analysis and presentation of scrambling and scrambling in Afrikaans will rely on. This has by no means been a comprehensive discussion– the purpose is to present a context for the following chapters.

Chapter 3

Scrambling

1. What is scrambling?

A scrambling grammar allows a set of argument ordering options deviating from what is considered the canonical argument-order of the sentence (Haider, 2006: 215). To illustrate: The embedded ditransitive German⁴ sentence below (1a) allows the subject *jemand* ('someone'), the indirect object *den Pennern* ('the bums'), and the direct object *ein paar Kippen* ('a few cigarettes'), to be freely ordered between the complementizer *dass* ('that') and the verb complex *gegeben hat* ('given has') without affecting grammaticality or eliminating the canonical interpretation, i.e. without affecting the grammatical relations between arguments as they apply in the unscrambled order. Examples (1a)-(1c) illustrate three of six possible ordering options. The canonical argument-order for the verb *geben* ('give') in (1a) is Subject (SUB)>>Indirect object (IO)>>Direct object (DO).

(1) German

- a. ...dass [jemand] [den Pennern] [ein paar Kippen] gegeben hat
 ...that someone_{NOM} the bums_{DAT} a few cigarettes_{ACC} given has
 SUB IO DO

“...that someone gave the bums a few cigarettes”

- b. ...dass [jemand] [ein paar Kippen] [den Pennern] gegeben hat
 ...that someone_{NOM} a few cigarettes_{ACC} the bums_{DAT} given has
 SUB DO IO

⁴ German examples will be used most frequently to illustrate scrambling. German exhibits a very flexible word order and allows for a useful way to distinguish different scrambling types. The flexibility exhibited by German is also used as a context in which to discuss the scrambling data I present on Afrikaans in the next chapter (Chapter 4).

- c. ...dass [den Pennern] [jemand] [ein paar Kippen] gegeben hat
 ...that the bums_{DAT} someone_{NOM} a few cigarettes_{ACC} given has
 IO SUB DO

(Putnam, 2007: 49, 50)

The canonical order (also referred to, in the literature, as the ‘base order’, ‘preferred order’, ‘natural order’, ‘default order’, or ‘neutral order’) does not require a special context to be considered *natural* (Hinterhölzl, 2006: 7). Scrambled orders (also referred to as the ‘non-canonical order’, ‘derived order’ or ‘non-standard order’) on the other hand, are marked (to varying degrees), *by definition*.

Scrambling is a displacement process that, unlike other types of syntactic movement, seems *optional*. There is no *syntactic context* in which an unscrambled order is ungrammatical, and scrambling never has to occur for grammaticality, i.e. a scrambled order is not compulsory (Haider, 2006: 213). A syntactic trigger, therefore, is not as obvious as it is for instances of *wh*-movement, focus movement, or DP-movement for (structural) case (Tada, 1993: 12; Mahajan, 1990: 7). These types of movement, if a language realizes them overtly, are obligatory if the relevant formal features are present in the derivation (Chomsky, 1995: 243). It has been tempting, for this reason, to treat scrambling as an operation occurring outside of syntax (Ross, 1967; Chomsky & Lasnik, 1977).

However, scrambling clearly interacts with syntactic processes (i.e. at LF) like anaphor binding, weak-crossover, and scope (I discuss some of these in section 3) (Haider, 2006: 208; Tada, 1993: 12; Mahajan, 1990:15). Haider (2006: 28) also notes that the existence of scrambling appears to be grammatically conditioned: Scrambling is strongly correlated with head-finalness (i.e. an OV-base order) and a rich case-morphology.

Scrambling is a challenge in a minimalist framework because scrambling is an operation that appears to be optional in the sense that, given a particular Numeration and a particular set of formal features, a derivation can converge on an unscrambled

(canonical) order, or on a (set of) scrambled (non-canonical) order(s). A particular word order is not obligatory. Assuming that the canonical word-order and the scrambled word-order proceed from the same Numeration, it appears like a strong formal feature does not need to be resolved in the standard way. This does not fit well with the minimalist assumptions made thus far. Another problem that scrambling presents is that case assignment and θ -role assignment are traditionally assumed to be local operations occurring in designated positions between a suitable functional head and a (suitable) argument (Mahajan, 1990: 7). Scrambling (the strong variety that I discuss in Section 2), suggests that arguments and their case-assigners are not (necessarily) subject to a local relation (i.e. adjacency), but are free in the clause.

Scrambling's optionality can be dealt with in a derivational account as a matter of economy: There are two (or more) ways of assembling a sentence that are equally 'costly' (Fukui, 1993). In this sense, when a strong feature associated with scrambling is present in the derivation (whatever it may be), a strong feature is able to be checked in more than one possible configuration. It is thus never the case, in this situation, that movement is optional, i.e. that movement does not have to occur. Another approach is a base-generation approach, which assumes that arguments are freely generated in a number of possible positions/configurations. A base generation approach thus assumes that there is no movement at all, and hence there is no 'scrambling' operation (Bošković & Takahashi, 1998; Fanselow, 2001).

Based on the fact that scrambling does appear to have syntactic effects relying on relations established in a canonical order (i.e. movement chains) (see section 3) and the fact that scrambling does appear to rely on certain grammatical prerequisites (see section 3.4), this thesis will assume a derivational approach (following in the tradition of Mahajan, 1990; Tada, 1993; Miyagawa, 1994; Grewendorf & Sabel, 1999; Hinterhölzl, 2006; Haider, 2006).

2. Types of Scrambling

Scrambling is not a unified phenomenon: The term is often over-applied to any instance of word order flexibility (Hinterhölzl, 2006: 5). Scrambling types, however, can be distinguished based on: (1) Scrambling distance (i.e. clause-restrictedness), (2) Permutability (i.e. whether relative argument-order is affected), and (3) Movement type (i.e. A-/A'-movement) (following Grewendorf, 1992; Tada, 1993; Haider, 2006; Hinterhölzl, 2006; Putnam, 2007). Movement referred to as 'scrambling' in the literature can, broadly, be classified as either clause-internal (see section 2.1) or clause-external (see section 2.2), based on whether a particular constituent is restricted to movement within a single clause, or is able to move to a hierarchically higher clause. This section will discuss these different instances of scrambling descriptively (i.e. in a largely theory-neutral setting). Clause-internal and clause-external scrambling may exhibit different grammatical properties, and I look at some of these in section 3. Clause-internal, i.e. Middlefield (MF-)scrambling, will be of particular interest, as this is the type of scrambling characteristic of West Germanic languages and the type of scrambling that, as I attempt to show, is attested in certain constructions in Afrikaans (see Chapter 4).

2.1. Clause-internal scrambling

Following Tada (1993: 12), I distinguish between two kinds of clause-internal scrambling, namely short-distance scrambling (section 2.1.1) and medium-distance scrambling (section 2.1.2).

2.1.1 Short-distance scrambling

Short-distance scrambling comes in two varieties: Type 1 and Type 2. Short-distance scrambling Type 1 allows for the direct object (DO) of a sentence to appear on either side of a sentential adverb (ADV) or a negator (NEG). Examples (2a) and (2b) show that the DO *den Mann* ('the man'), can appear on either side of the ADV *gestern* ('yesterday'). Example (2a) represents the base/canonical order of the verb *sehen*

(‘see’) and (2b) represents the scrambled order. Note that the canonical order of the sentence arguments is maintained in both (2a) and (2b): SUB>>DO. Example (2c) represents an instance of this type of scrambling schematically: The DO moves out of VP across ADV.

(2) *German*

- a. ...dass ich gestern den Mann gesehen habe
...that I yesterday the man seen have
SUB ADV DO
- “...that I saw the man yesterday”
- b. ...dass ich den Mann gestern gesehen habe
...that I the man yesterday seen have
SUB DO ADV
- (Molnárfi, 2002:1108)
- c. SUB DO [_{VP} ADV ~~DO~~ V]

Short-distance scrambling Type 2 concerns the double object construction. Short-distance scrambling Type 2 allows for the DO and the IO to order freely relative to each other. In example (3), with the verb *geben* (‘give’), the DO *das Buch* (‘the book’) can appear on the right (3a) or on the left (3b) of the IO *dem Jungen* (‘the boy’). Example (3a) represents the canonical order while (3b) represents the scrambled order. Note that short-distance scrambling Type 2 permutes the canonical order (SUB>>IO>>DO) of the arguments, allowing the sentence objects to invert positions: IO>>DO (3a), DO>>IO (3b). Example (3c) represents an instance of this type of scrambling schematically: The DO moves out VP across IO.

(3) *German*

- a. weil Peter dem Jungen das Buch gegeben hat
since Peter the boy the book given has
SUB IO DO
- b. weil Peter das Buch dem Jungen gegeben hat
since Peter the book the boy given has
SUB DO IO

“...since Peter gave the book to the boy”

(Grewendorf, 1992: 34)

c. SUB DO [_{VP} IO \emptyset V]

I draw a distinction between instances of scrambling that are argument-order permuting and instances of scrambling that maintain the canonical argument-order: Scrambling operations that permute the canonical argument-order of a sentence are referred to as instances of *strong scrambling*, and scrambling operations that do not permute the canonical order of arguments are referred to as instances of *weak scrambling* (following Putnam, 2007: 47-50). Short-distance scrambling Type 1 is weak scrambling, while short-distance scrambling Type 2 is an instance of strong scrambling.

Short-distance scrambling Type 1, as observed in Afrikaans, is sometimes referred to as *object shift* (see Conradie, 2007: 73). In example (4a) the DO *daardie man* (‘that man’) follows the NEG *nie* (‘not’). In (4b) the DO precedes NEG. But object shift is not a uniform operation across languages, specifically in terms of optionality. Afrikaans object shift differs from ‘true’ object shift in a number of ways.

(4) Afrikaans

a. Ek het nie daardie man geken nie
I have not that man known not
NEG DO

b. Ek het daardie man nie geken nie
I have that man not known not
DO NEG
“I did not know that man”

(Conradie, 2007:73)

Mainland Scandinavian languages (henceforth MSc), i.e. Danish, Norwegian, and Swedish (Thráinsson, 2001: 150), show a displacement property in main clauses very similar to short-distance scrambling Type 1, referred to as *object shift* (Vikner, 2006: 393, 394). A sentence object moves (leftward) across ADV and/or NEG. Example (5) illustrates this type of movement schematically: The DO moves out of VP across ADV.

(5) SUB V DO [_{VP} ADV \emptyset ψ]

MSc object shift, like Afrikaans object shift, is order-preserving (i.e. arguments do not permute their canonical hierarchy). However, there are a number of differences that set MSc object shift apart from the kind of object shift observed in Afrikaans: (1) Object shift in MSc requires V2 and cannot apply without V2 (object shift in MSc is therefore limited to main clauses), (2) Object shift applies only to pronouns, (3) Object shift is *obligatory* (given V2).

MSc object shift requires the verb to move out of VP (V-raising) to V2 position. This requirement falls under ‘Holmberg’s generalization’ which states that object shift is dependent on V-raising (Vikner, 2006: 394-395). Object shift cannot take place when there is no V2 and object shift must take place when there is V2. Examples (6a)-(6d) all require V2 for grammaticality. Object shift only applies to pronouns (Vikner, 2006: 394-395). In example (6a) moving the definite DO *bøgerne* (‘the books’) out of VP results in ungrammaticality. In example (6b) with the pronominal DO *dem* (‘them’), the DO must object shift out of VP. In example (6c) below, failure to move the pronominal DO *den* (‘it’) out of VP (over the NEG *aldrig* (‘never’) results in ungrammaticality.

(6) Danish

- a. *Peter læst bøgerne uden tvivl aldrig [_{VP} læst bøgerne]
 Peter read books-the without doubt never
 V DO ADV NEG ψ ~~DO~~
- b. Peter læst dem uden tvivl aldrig [_{VP} læst dem]
 Peter read them without doubt never
 V DO ADV NEG ψ \emptyset
- c. *Hvorfor læst Peter aldrig [_{VP} læst den]?
 Why read Peter never them
 V NEG ψ DO

(Vikner, 2006: 393)

In Afrikaans object shift is observed in main clauses (where V2 applies) (4a)(4b) and embedded clauses with an overt C-element (where V2 does not apply) (7a)(7b), object shift is also not obligatory, as the object may appear on either side of the sentence ADV, despite V2. In the embedded clause examples (7a) and (7b) the DO *daardie man* ('that man') can appear following the NEG *nie* ('not') (7a), or preceding NEG (7b). Afrikaans object shift may also apply to any DP, and is not limited to pronouns.

(7) Afrikaans

- a. ...dat ek nie daardie man geken het nie
 ...that I not that man known have not
 NEG DO
- b. ...dat ek daardie man nie geken het nie
 ...that I that man not known have not
 DO NEG
 "I did not know that man"

There are some interesting questions to be raised about these object shift constructions and their relation to V-raising. This thesis, however, will be restricted to strong scrambling constructions. There is a specifically striking contrast between Afrikaans and other object shift languages: Afrikaans strong scrambling (scrambling Type 2 that I discuss in Chapter 4) is not possible with V2. This seems to be exactly the opposite requirement for what we see in MSc languages (see Chapter 5). In light of the differences between Afrikaans object shift, and *true* object shift, I will continue to refer to Afrikaans object shift as 'weak scrambling' (or short scrambling Type 1).

2.1.2 Medium-distance scrambling

Medium-distance scrambling is another variety of strong scrambling. The DO or the IO may alter the canonical SUB>>IO>>DO order of the sentence by appearing in the pre-subject position. In example (8), with the verb *geben* ('give'), the IO *den Pennern* ('the bums') or the DO *ein paar Kippen* ('a few cigarettes) can appear in the pre-subject

position (8a) (8b). Example (8c) represents an instance of this type of scrambling schematically: The DO or IO moves out of VP to a pre-subject position.

(8) *German*

- a. dass den Pennern jemand ein paar Kippen gegeben hat
 that the bums_{DAT} someone_{NOM} a few cigarettes_{ACC} given has
 IO SUB DO
 “...that someone gave the bums a few cigarettes”
- b. dass ein paar Kippen jemand den Pennern gegeben hat
 that a few cigarettes_{ACC} someone_{NOM} the bums_{DAT} given has
 DO SUB IO
- c. DO/IO SUB [_{VP} ~~DO~~/~~IO~~ V]
- (Putnam, 2007:49, 50)

Medium-distance scrambling is not possible in Dutch and Afrikaans without an obligatory special intonation pattern. In example (9), with the verb *kopen* ('buy'), the scrambled order (9b) with the DO *den boeken* ('the books') in pre-subject position is ungrammatical.

(9) *Dutch*

- a. dat Jan den boeken niet koopt
 that John the books not buys
 SUB DO
 That John doesn't buy the books“
- b. *dat den boeken Jan niet ~~den boeken~~ koopt
 that the books John not buys
 DO SUB ~~DO~~

However, the scrambled order in (9b) becomes marginally acceptable with strong emphasis (indicated in capitalized bold lettering) on the scrambled DO, as example (10a) indicates, or, preferably, when focus-markers such as *zulke* ('such') and (contrastive) *zelfs* ('even') are added (Hinterhölzl, 2006: 35) (10b). In (10b) ' / ' indicates rising intonation on the moved (topicalized) DO, and ' \ ' indicates a fall-pitch on the focus-element and the rest of the clause.

(10) Dutch

- a. ?...dat **DEN BOEKEN** Jan niet ~~den boeken~~ koopt
 ...that these books John not buy
 DO SUB DO

“...that John did not buy the books”

- b. ...dat /ZULKE boeken \zelfs Jan niet ~~zulke boeken~~ koop
 ...that such books even John not buy
 DO SUB -DO

“...that **such** books even John did not buy” (Hinterhölzl, 2004: 36)

The same restriction applies to Afrikaans. In example (11) die DO *die boek* (‘the book’) is not allowed to move to the pre-subject position (11a) without focus intonation on the DO (11b) (indicated in bold and capitalized lettering).

(11) Afrikaans

- a. *...dat die boek Jan nie gelees het nie
 ...that the book John not read has not
 DO SUB

“...that John has not read the book”

- b. ...dat **DIE BOEK** Jan nie gelees het nie
 ...that the book John not read has not
 DO SUB

Given that (10a)-(10b) and (11b) are the only acceptable ways of placing an object in front of the subject in Dutch and Afrikaans, it appears that this word order is not an instance of medium-distance scrambling, but rather appears to be an instance of *focus fronting* (Haider, 2006: 209). Focus fronting is not considered to be movement within MF, but movement into VF (unless one assumes (recursive) Topic and Focus positions that are also able to occur in the MF (see Grewendorf, 2005: 87).

2.2. Clause-external scrambling

Clause-external, or "Long-distance", scrambling allows constituents to appear in a hierarchically higher clause. In the Russian sentence (12), the DO *Borisa* ('Boris') is able to scramble out of the subordinate CP into the main clause. In the Japanese example (13) the DO *hon-o* ('book') is scrambled out of the embedded clause to the main clause.

(12) *Russian*

Ja Borisa xotel, [CP čtoby Ira Borisa pozvonila]
 I Boris wanted, that Ira phone
 DO \emptyset
 "I wanted Ira to phone Boris." (Chocano, 2007: 9)

(13) *Japanese*

kono hon-o Bill-ga [CP John-ga Mary-ni ~~hon-o~~ ageta] –to omotteiru
 this book-acc Bill-nom John-nom Mary-dat gave -comp think
 DO \emptyset
 "This book, Bill thinks that John gave to Mary" (Tada, 1993: 15)

Extraction out of finite embedded clauses, however, is not allowed in German (Grewendorf & Sabel, 1999). In example (14), scrambling the DO *dieses Buch* ('this book') out of the embedded CP results in ungrammaticality.

(14) *German*

dass dieses Buch Hans dem Studenten gesagt hat
 that this book-ACC Hans-NOM the student-DAT said has
 DO
 [CP dass ~~dieses Buch~~ Maria dieses Buch besitzt]
 that \emptyset - Maria_{NOM} owns
 "that book, Hans said to the student that Mary has" (Grewendorf, 2005: 88)

German does, however, allow focus movement out of finite embedded clauses (Haider & Rosengren, 1998). Focus movement is associated with an (obligatory) fall-rise tone

on the element that has undergone movement (capitalized and in bold lettering in the example) and a fall-tone on the contrasted focus element (Hinterholzl, 2006: 35) (see subsection 2.1.2). In example (15) the DO *diese Frage* ('this question') can be focus fronted in a higher CP with special intonation on the DO.

(15) *German*

dass just **DI**Ese Frage alle glaubten
 that exactly this question everybody believed
 DO
 [_{CP} dass sie unbedingt just diese Frage beantworten müssten]
 that they absolutely DO answer should
 "that exactly this question, everyone believed they absolutely should answer"
 (Grewendorf, 2005: 88)

The different instances of scrambling discussed above (under 'short-distance scrambling') are all strictly clause-bound and are not associated with an obligatory intonation pattern. Hence, instances of focus movement (i.e. 'focus fronting') will be excluded from my treatment of scrambling in West Germanic.

A constituent in German can also leave an embedded finite clause when the moved element is extracted out of an infinitival non-finite subordinate-clause (16). However, this operation is restricted to a set of verbs requiring V-raising and allowing reconstruction that are referred to as 'coherent infinitives' (see Grewendorf & Sabel 1994; Hinterhölzl, 2006: 35; Haider, 2009: 209). Therefore, there is no such thing as long-distance (Russian- or Japanese-style) scrambling in German, only long distance movement under special (restructuring) circumstances and focus movement with special intonation.

(16) *German*

...dass sie der Mann [_{CP} sie zu besuchen] versprach
 ...that her the man_{NOM} to visit promised
 DO DO
 "...that the man promised to visit her."
 (Hinterhölzl, 2006: 16)

2.3. Summary

Clause-bounded (MF) scrambling includes short-distance scrambling (Type 1 and Type 2), and Medium-distance scrambling. Short-distance scrambling Type 1 concerns the placement of objects relative to a sentential ADV or NEG. Short-distance scrambling Type 2 concerns double object constructions and the placement of sentence objects relative to each other. I also mention, and set aside, MSc object shift which is different from the aforementioned operations. True object shift is forced by V-raising and is limited to pronominal arguments. Medium-distance scrambling concerns the placement of an object into a pre-subject position. Long-distance scrambling concerns the placement of an embedded object into a hierarchically higher clause. Long-distance scrambling is not possible in German, Dutch or Afrikaans. Long-distance movement is only available to German in some special cases, i.e. infinitival non-finite subordinate clauses (e.g. restructuring contexts, with clause-union and verb raising (Hinterhölzl, 2006: 5)). I have also discussed instances of focus fronting. Focus fronting concerns the placement of an object into a pre-subject position in the VF and the obligatory application of focus intonation on the moved object. Focus fronting is also not clause-bound, and may move a constituent in to a hierarchically higher clause where the object is also required to have focus intonation. Furthermore, in this thesis, I have drawn a distinction between varieties of MF scrambling that allow the arguments of the sentence to deviate from the canonical SUB>>IO>>DO order, and varieties of scrambling that require that the relative order of arguments are maintained. The former is referred to as “strong” scrambling and the latter is referred to as “weak” scrambling. The ability to permute the canonical order of arguments is strong scrambling’s defining property and the reason why strong scrambling is referred to as a ‘free-word order phenomenon’. It is this kind of strong scrambling that I attempt to identify in Afrikaans.

3. Grammatical effects of scrambling

In this section I discuss some grammatical properties exhibited by different types of scrambling in a movement-based analysis. Cross-linguistically different types of scrambling do not exhibit identical grammatical properties (Grewendorf & Sabel 1999; Tada, 1993). Scrambling interacts with syntax, and has effects on binding relations, scope, and information structure. A question that remains is: what triggers a given instance of scrambling? Is scrambling triggered by lexically related checking operations in the internal domain (e.g. case-checking), or is it motivated by topic/focus or discourse related requirements. An analysis that would address this question is outside the scope of this thesis. However, I offer some discussion of certain grammatical properties associated with German MF scrambling, which may ultimately inform the debate. Apart from being strictly clause-bound, and not associated with a special (obligatory) intonation pattern, one type of German MF scrambling “feeds-and-bleeds”⁵ binding relations, and does not allow reconstruction, while another type of German MF scrambling exhibits weak cross-over effects (WCO), and may reconstruct for scope (section 3.3). I also discuss some discourse effects associated with weak scrambling languages; Afrikaans and Dutch (section 3.5.).

3.1. A/A' movement

An instance of phrasal movement is, traditionally, either Argument-movement (A-movement), or non-Argument-movement (A-bar or A'-movement') (see e.g. Mahajan, 1990: 7). A- and A'-movement differ in terms of (1) the kind of elements that undergo movement, (2) the properties the (left-behind) copies in the movement-chain exhibit from their positions and (3) whether a moved element is subject to binding conditions (Mahajan, 1990: 16, 17; Chomsky, 1995: 210). A-movement is restricted to local domains and these domains are associated with case-licensing and θ -role assignment (Mahajan, 1990: 7; Chomsky, 1995: 63). Chomsky (1995) refers to positions that exhibit the basic properties of A-positions as ‘L-related’ positions, i.e. ‘lexically related’ positions

⁵ A phrase borrowed from Neeleman & Van De Koot (2008:1).

(pg 196). These positions are associated with the internal domain of the clause and the arguments of the predicate. Structurally, L-related positions include the specifier and complement positions of V, v, and T (Mahajan, 1986: 10; Chomsky, 1995: 196). An element in an A-position can establish new binding properties, for instance: the ability to bind anaphors and the ability to neutralize weak cross-over effects (WCO) (Tada, 1993: 16; Mahajan, 1990: 16,17).

A'-movement applies to non-arguments, scope taking elements like *wh*-phrases and other operators (Mahajan, 1990: 18). Chomsky (1995) refers to these positions as 'non L-related positions' (Chomsky, 1995: 196). Structurally these positions correspond to [Spec, C] and adjunction positions. An element in an A'-position cannot bind anaphors, and cannot neutralize WCO.

In example (17a) 'The men' is able to bind the pronominal from the position it has moved to. The same holds for the *wh*-phrase in (17b): 'Who' is able to bind 'his' in the position it has scrambled to. No WCO effect is observed even though the scrambled element has scrambled over a potential binder. These positions are thus L-related (exhibiting A-properties).

(17) *A-movement*

- a. The men_i seem to each other_i [~~the men~~ to be nice]

(Grewendorf & Sabel, 1999: 8)

- b. Who_i seems to his_i mother [~~who_i~~ to be sick]?

(Tada, 1993: 18)

Contrast these examples with example (18). In example (18a) 'the guests' is unable to bind 'each other's dance partners' from the position it has moved to. In example (18b) 'who' is unable to bind 'his mother' from the position it has moved to. Here we see a WCO effect. These positions are therefore non L-related (exhibiting A'-properties).

(18) *A'-movement*

- a. *The guests_i, [each others_i's dance partners] criticized ~~the guests~~
(cf. The guests criticized each other's dance partners)

(Grewendorf & Sabel, 1999: 8)

- b. *Who_i does his_i mother love ~~who~~_i [WCO]

(Tada, 1993: 16)

Anaphor binding supports an A'-movement analysis of medium-distance scrambling and an A-movement analysis of short-distance scrambling Type 2 (Grewendorf & Sabel, 1999: 3). German medium-distance scrambling is not uncontroversial (see Mahajan, 1990). The issue with medium-distance scrambling is whether the moved constituent is inside MF (in a [Spec, T] position) or has moved into VF (in a [Spec, C] position) (Mahajan, 1990; Grewendorf & Sabel, 1999). I discuss some binding data below.

3.2. Binding

Short-distance scrambling Type 2

Scrambling a potential binder to a higher surface position extends its c-command domain and enables new binding possibilities. In example (19), a Principle A effect is observed when the DO *die Zeugenaussagen* ('the testimonies') is (short) scrambled from its base position to a position where it c-commands the DP anaphor (IO) *einander* ('each other'). *Einander* is now interpreted as co-referential with the c-commanding phrase *die Zeugenaussagen*. Even though the DP has 'crossed-over' another potential binder, there is no crossover effect. Here it would appear that the scrambled arguments occupies an L-related position (exhibiting A-properties).

(19) *German*

daß man	die Zeugenaussagen _i	einander _i	die Zeugenaussagen_i *	anglich
that one	the testimonies	each-other		adjusted
SUB	DO	IO	ÐØ	

“...that the testimonies were adjusted to one another.”
(Haider, 2006: 215)

Permuting the word order also destroys binding relations that held in the unscrambled configuration. In example (19) the DO does not reconstruct in its base position, and the original relation is now lost.

Medium-distance scrambling

However, medium-scrambling a DO to a pre-subject position does not have the same effect. In example (20) below the DO *den Studenten* ('the student') cannot bind the SUB *sich* ('himself') from its scrambled position without a WCO. Medium-scrambling cannot create new binding possibilities. Here an A'-analysis is more suitable (Grewendorf & Sabel, 1999: 9)

(20) *...weil den Studenten_i die Lehrer von sich_i zweifellos
...since the student the teachers of himself undoubtedly
DO SUB
~~den Studenten_i~~ in guter Erinnerung behalten haben
DO in good memory kept has

“The teachers of himself have undoubtedly kept the student in good memory”

(Grewendorf & Sabel, 1999: 9)

3.3. Scope and reconstruction

In example (21a) the quantificational DO *mindestens ein Bild* ('at least one picture') has scrambled over the quantificational IO *fast jedem Experten* ('(to) almost every expert'). Scrambling in this case may or may not invert the scoping relation. One interpretation relies on the overt, derived surface DO, and the other interpretation relies on the copy of the DO (Haider, 2006: 216; 222; Hinterhölzl, 2006: 37). In the case where a scope ambiguity arises, movement would have to be analyzed as an instance of operator movement, i.e. A'-movement. When a scope ambiguity does not arise, and A-movement

analysis is appropriate. Haider (2006) notes that the ambiguity does not arise for all speakers. It should be noted here that in the base order IO>>DO (i.e. when no scrambling has occurred), there is no ambiguity (21b).

(21) *German*

- a. daß man mindestens ein Bild fast jedem Experten
that one at least one picture almost every expert
SUB DO IO
~~mindestens ein Bild~~ zeigte
showed
 $\bar{D}\bar{O}$
“at least one picture was shown to almost every expert.” (Haider, 2006:216)
- b. daß man mindestens einem Experten fast jedes Bild zeigte
that they (to) at least one expert almost every picture showed
SUB IO DO

(Haider, 2006:216)

3.5. Discourse and semantic effects

Afrikaans and Dutch are regarded as weak scrambling languages (Putnam, 2007: 50; De Hoop, 2003: 201; Haider, 2006: 239; Molnárfi: 2002; Neeleman & Van De Koot, 2008), i.e. these languages only allow weak scrambling. Weak scrambling, as discussed in Chapter 3, concerns the placement of the object(s) relative to a sentential ADV (or NEG) in the sentence.

The position of the DO relative to the sentence ADV (or NEG) does have discourse and semantic effects (Zwart, 1993: 48, 49). Regarding ADVs, for instance, given neutral intonation, a DO is interpreted as either old- or new information depending on its placement relative to ADV. A DO on the right of ADV generally represents ‘new information’ (and is usually emphasized accordingly) (22a) while a DO on the left of ADV represents ‘old information’ (and is usually defocused) (22b) (Zwart, 1993: 49). It

should be noted that the emphasis is not obligatory for grammaticality. Both orders are possible derivations.

(22) *Dutch*

- a. Jan heeft gisteren Marie gekust [new information]
 John has yesterday Mary kissed
 ADV DO
 “John kissed Mary yesterday” (Zwart, 1993: 48)
- b. Jan heeft Marie gisteren gekust [old information]
 John has Mary yesterday kissed
 DO ADV

Weak scrambling is also subject to a *definiteness effect*. Definite DPs may weak scramble freely, while weak scrambling *indefinite* DPs have a more marked effect on interpretation (Molnárfi: 2002: 1128; Zwart, 1993: 49; De Hoop, 2003: 203). In example (23) the definite DP object *de schakers* (‘the chessplayers’) may be ordered to the right (23a) or left (23b) of the ADV *gisteren* without altering the sentence’s discourse interpretation. In example (24) the indefinite DP object *schakers* (‘chess players’) cannot weak scramble across the ADV *gisteren* (‘yesterday’) without affecting the interpretation of the sentence. An indefinite DP on the right of ADV generally yields an *existential reading* (24a), while an indefinite on the left of ADV produces a *generic reading* (24b) (Molnárfi: 2002: 1112; Haider, 2006: 213).

(23) *Dutch*

- a. ...dat hij gisteren de schakers heeft gezien
 ...that he yesterday the chessplayers has seen
 ADV DO
 “...that he saw the chess players yesterday” (Molnárfi: 2002: 1112)
- b. ...dat hij de schakers gisteren heeft gezien
 ...that he the chessplayers yesterday has seen
 DO ADV

(24) *Dutch*

- a. ... dat hij gisteren schakers heeft gezien [existential]
 ...that he yesterday chessplayers has seen

ADV DO

“...that he saw chess players yesterday” (Molnárfi: 2002: 1112).

- b. ...dat hij schakers gisteren heeft gezien [generic]
 ...that chessplayers yesterday has seen
 DO ADV

Whether the discourse/interpretive effects can be considered a *trigger* for weak scrambling (or strong scrambling) rather than a correlated phenomenon/operation is another question, i.e. whether discourse features operate within the syntactic component (Neeleman & Van De Koot, 2008; Fanselow & Lenertová: 2011). Scrambling could be analyzed as ‘interpretation driven’, having to conform to information-structure/information-packaging requirements (Hoyer, 2001).

The status of ADV in weak scrambling constructions, however, is not entirely clear. According to one view, ADV marks the VP boundary and a DP's position on the left/right of ADV indicates a VP-external/VP-internal position, respectively (Haider, 2006: 240; Molnárfi, 2002: 1113). The VP-internal object is assumed to either move across the ADV to a VP-external position (DO>>ADV), or remain in situ (ADV>>DO). In Afrikaans two place predicates there appears to be a correlation between the occurrence/non-occurrence of weak scrambling (the definite DP) and the appearance/non-appearance of the prepositional particle *vir* ('to'/'for') (see Molnárfi, 2002). Another option is that ADV freely attaches to the sentence. Indeed, the placement of an ADV in Afrikaans does appear to be free. In example (25) the temporal ADV *vandag* (today) can appear in any position (except between the finite verb and its auxiliary) without affecting the propositional structure of the sentence. One option is to conclude that ADV attaches freely to various sites in MF (Neeleman & Reinhart, 1998: 311 consider a similar idea for Dutch; see also Haider & Rosengren, 1988).

(25) *Afrikaans*

- ...dat (vandag) hy (vandag) die boek (vandag) gelees (*vandag) het (vandag)
 ...that he the book read has
 “...that he read a book today.”

A closer look at the nature of ADVs and the different types of ADVs is necessary as well as a closer look at the relationship between discourse acceptability and grammaticality. This, however, falls outside the scope of this thesis. The use of employing the position of DPs relative to ADV as a diagnostic for the DPs position inside/outside VP would have been potentially helpful for my analysis of Afrikaans strong scrambling constructions, but given the unclear status of adverbs regarding their syntactic position, I leave these issues aside in the remainder of this thesis.

3.5. Grammatical prerequisites for scrambling

Two factors and their presence in a grammar have, traditionally, been associated with scrambling: (1) a rich case morphology, and (2) an OV-base order. In order to scramble, a language must possess both (1) and (2).

The restricted ordering options of non-scrambling languages is, on the one hand, assumed to be a side-effect of an 'impoverished' case system (Haider, 2006: 240, Müller, 2002:9). Arguments are more likely to be able to freely order if their grammatical relation is morphologically indicated. If arguments are not overtly marked, then the grammatical relation between arguments is positionally determined (Haider, 2006: 239).

The correlation between languages with rich case morphologies and the capacity for free argument ordering is well-observed (McFadden, 2004: 149). Languages with rich case morphologies (e.g. German, Japanese, Russian, and Hindi for instance) license scrambling while languages without rich case-morphologies (e.g. English, Dutch, and Afrikaans) have rigid word orders and do not allow (strong) scrambling. However, in chapter 4 I challenge this generalization by identifying instances of strong scrambling in certain Afrikaans double object constructions.

Head-finalness is another prerequisite for scrambling, i.e. an OV-base order (Haider, 2006: 28; Neeleman & Reinhart, 1998: 311).

The correlation between OV-base orders and free word order is also a well-observed phenomenon. Amongst the Germanic languages, virtually all languages with OV-base order allow scrambling, while virtually all those with a VO-base order do not (Neeleman & Reinhart, 1998: 311; Fukui, 1993). However, not all OV-base order languages are considered to allow *strong scrambling*. Argument permutation requires, in addition to an OV-base order, overtly case-marked DPs. Presumably this is the reason why Afrikaans and Dutch, which are traditionally analysed as having OV-base orders (in embedded clauses with an overt C-element), are not expected to license strong scrambling. I challenge this assumption in Chapter 4.

Icelandic is one example of a language which demonstrates that rich case morphology is not a sufficient condition for scrambling: Icelandic has a rich case morphology and morphological case is overtly realized on all DPs, yet Icelandic does not allow scrambling (a strict SUB>>DO>>IO order must be retained) (see Vikner, 2006: 422, 412; Collins & Thráinsson, 1996: 421). A plausible explanation for why a language like Icelandic does not allow scrambling, despite a rich case morphology, is that it has a VO base-order (before V2).

But there are complications that challenge the traditional generalizations: Polish (see Haegeman, 1995) and Russian (see Müller & Sternefeld, 1993), for instance, have rich case morphologies but are considered VO-base languages, and yet Polish and Russian *do* allow scrambling.

While weak scrambling (order-preserving leftward movement of an object) is permitted in Afrikaans and Dutch (but not in a VO-language such as English), order-permuting movement is not expected. Afrikaans, after all, only marks case on personal pronouns, has no overt person, number, or gender agreement, and has an extremely limited inflectional system (Botha & Oosthuizen, 2009; Biberauer, 2001: 21). Optional argument placement is therefore unexpected. Chapter 4, however discusses instances of strong scrambling in Afrikaans and therefore challenges the assumption that languages without rich case morphology do not allow strong scrambling.

4. Conclusion

This chapter has attempted to identify and define what is meant by 'scrambling' in West Germanic. The chapter identifies two main types of scrambling: clause-internal and clause-external scrambling. I have pointed out that West Germanic scrambling is strictly clause-internal. Clause-internal scrambling can be either A-movement to an L-related position, or A'-movement to a non L-related position. Short-distance scrambling Type 2 appears to be like A-movement, while medium-distance scrambling appears to fit an A'-analysis. Scrambling also has discourse/semantic effects, affecting information structure (old/new) and interpretation (generic/existential). The main point of this chapter was to develop a way to identify different instances of scrambling. I also attempted to show that scrambling clearly interacts with grammar. Not only are there semantic consequences to scrambling an element, but the very possibility of scrambling relies on certain grammatical prerequisites. The following chapter will examine scrambling structures I have identified in Afrikaans double object constructions.

Chapter 4

Scrambling in Afrikaans

Afrikaans allows certain double object constructions (DOCs) to undergo what looks like *strong scrambling*, i.e. short-distance scrambling Type 2. Short-distance scrambling Type 2 allows the DO to optionally invert the canonical IO>>DO word order by moving across the IO (1). In example (2) the DO *die man* ('the man') can remain in the canonical IO>>DO order (2a), or appear in the inverted DO>>IO order (2b), without affecting the grammatical relation between the object arguments.

(1) SUB DO [_{VP} IO $\bar{\Theta}$ V]

(2) a ...dat die vrou die monster die man belowe het [canonical]
 ...that the woman the monster the man promised has
 IO DO
 "...that die woman promised the man to the monster"

 b. ...dat die vrou die man die monster belowe het [scrambled]
 ...that the woman the man the monster promised has
 DO IO

These structures challenge the status of Afrikaans as a weak scrambling language. In this chapter I discuss, firstly, different types of double object constructions (section 1). I discuss the dative double object construction (PP-DOC) (section 1.1), which appears to reinforce the generalization that overt morphological case is required for scrambling. I then discuss the double-(DP)-object construction (DOC) in Afrikaans (section 1.2). I present data from Afrikaans double object constructions distinguishing what I call "Rigid DOCs" (section 1.2.1) from "Flexible DOCs" (section 1.2.2). Rigid DOCs block scrambling. Flexible DOCs behave like example (2), allowing the object arguments two alternative ordering options. Flexible DOCs appear to allow *strong scrambling* with no overt (morphological) case marking requirement. In section 1.3 I discuss the conditions Afrikaans requires for scrambling.

1. Double object constructions

1.1. The Dative: PP-DOCs

The correlation between overt case marking of an argument and its ability to scramble seems to be supported by Afrikaans PP-DOCs (at least superficially), if it is assumed that an overt P in Afrikaans can act as a morphological case marking element (see Den Besten, 2000: 950-951; Haider, 2006: 240). When an object is embedded in a PP headed by an overt preposition, for example *vir* ('to') in (3a) and (3b), free-ordering is observed: The IO *vir Piet* ('to Piet') can freely appear in a DO>>IO order or in IO>>DO order.

(3) Afrikaans

- a. ...dat Jan 'n koek vir Piet gebak het
 ...that John a cake _{DAT}Peter baked has
 SUB DO IO
- b. ...dat Jan vir Piet 'n koek ~~vir Piet~~ gebak het
 ...that John _{DAT}Piet a cake baked has
 SUB IO DO ~~IO~~
- "...that John baked Peter a cake"

PP-DOCs do have a canonical SUB>>DO>>PP order (in contrast to the canonical SUB>>IO>>DO order of DOCs) (Haider, 2006: 241; Zwart, 1993: 50). In a non-canonical order, the assumption could be that the PP-object has moved from its base position to a derived position. The placement of the PP in a PP>>DO position is thus assumed to be an instance of scrambling: The PP moves across the DO (Haider, 2006: 241). PPs can appear virtually anywhere in the clause. In example (4) the PP *vir Piet* ('to Piet') can appear in any position (except between the finite verb and its auxiliary). PPs do not appear to be limited to any positions within the clause, and freely attach to various sentence positions. As will be seen in the next section, DPs are much more restricted.

- (4) ...dat (vir Piet) Jan (vir Piet) 'n koek (vir Piet) gebak het (vir Piet)

The kind of flexibility that PPs exhibit is the only acknowledged instance of flexibility that looks like strong scrambling in Afrikaans (see Conradie, 2007: 77), otherwise Afrikaans is considered a weak scrambling language. However, I try to show that Afrikaans allows a certain strong scrambling construction without the requirement of morphological case identification or marking.

1.2. The double object construction: DOCs

A double object construction that involves two DPs is referred to as the Double Object Constructions (DOC) in this thesis. Afrikaans DOCs have no overt case marking on their DP objects and thus the prediction is that Afrikaans DOCs should be very rigid, relying on designated case positions and a strict word order in the MF: SUB>>IO>>DO (Haider, 2006: 239). In what follows, I distinguish Rigid DOCs from Flexible DOCs. DOCs follow a strict word order in *main clauses*. Rigid DOCs maintain a SUB>>IO>>DO argument ordering in main and embedded clauses. Flexible DOCs only exist within the embedded context. Flexible DOCs allow object DPs to optionally invert (i.e. they allow short scrambling Type 2). While these DP-objects are not as flexible as PPs, the fact that they can undergo strong scrambling in Afrikaans is not expected and has not been discussed in the literature, to the best of my knowledge.

1.2.1. Rigid DOCs

Afrikaans DOCs, in general, maintain a rigid SUB>>IO>>DO argument hierarchy in the MF. This also holds for the embedded context. I refer to these structures as Rigid DOCs. In example (5), with the verb *bak* ('bake'), the DO *die koek* ('the cake') cannot scramble over the IO *die skool* ('the school'). Scrambling is not possible in the main clause (5b) or the embedded clause (5d). In example (6), with the verb *verf* ('paint'), the DO *'n skildery* ('a painting') cannot scramble over the IO *die burgermeester* ('the mayor'). Scrambling is not possible in the main clause (6b) or in the embedded clause

(6d). In example (7), with the verb *bou* ('build'), the DO *die kamer* ('the room') cannot scramble over the IO *haar seun* ('her son'). Scrambling is not possible in the main clause (7b) or in the embedded clause (7d).

(5) *Bak*

- a. Hy het die skool die koek gebak
 He has the school the cake baked
 IO DO
 "He baked a cake for the school (to have)"
- b. *Hy het die koek die skool gebak
 He has the cake the school baked
 DO IO
- c. ...dat hy die skool die koek gebak het
 ...that he the school the cake baked has
 IO DO
 "...that he baked the cake for the school (to have)"
- d. *...dat hy die koek die skool gebak het
 ...that he the cake the school baked has
 DO IO

(6) *Verf*

- a. Hy het die burgermeester 'n skildery geverf
 He has the mayor a painting painted
 IO DO
 "He painted a painting for the mayor (to have)"
- b. *Hy het 'n skildery die burgermeester geverf
 He has a painting the mayor painted
 DO IO
- c. ...dat hy die burgermeester 'n skildery geverf het
 ...that he the mayor a painting painted has
 IO DO
 "...that he painted a painting for the mayor (to have)"
- d. *...dat hy 'n skildery die burgermeester geverf het
 ...that he a painting the mayor painted has
 DO IO

(7) *Bou*

- a. Sy het haar seun die kamer gebou
She has her son the room built
IO DO
“She built her son a room (to have)”
- b. *Sy het die kamer haar seun gebou
She has the room her son built
DO IO
- c. ...dat sy haar seun die kamer gebou het
...that she her son the room built has
IO DO
“...that she built her son a room (to have)”
- d. *...dat sy die kamer haar seun gebou het
...that she the room her son built has
DO IO

The only way to rescue these scrambled constructions (the (b) and (d) examples) is to emphasize (i.e. by *focus intonation*) individual arguments or combinations of arguments (see Zwart, 1993: 48, 49). For instance, in example (8) emphasizing the DO (8a), the IO (8b), or the verb (8c), enables acceptability. Intonation is obligatory for grammaticality in these constructions, unlike the optional intonation that can be added to weak scrambling constructions (see Chapter 3). The same holds for the main clause examples.

- (8) a. ...dat hy DIE KOEK die skool gebak het
b. ...dat hy die koek DIE SKOOL gebak het
c. ...dat hy die koek die skool GEBAK het

1.2.2. Flexible DOCs

Flexible DOCs, unlike Rigid DOCs, appear to allow for optional inversion of its objects, i.e. canonical IO>>DO or non-canonical DO>>IO. Flexible DOCs only exist in an embedded context, and under specific conditions (I discuss these in section 1.3).

In example (9a) and (9b), with the verb *belowe* ('promise'), the IO *die polisieman* ('the policeman') and the DO *'n medepligtige* ('an accomplice') may appear in canonical IO>>DO order (9a) or non-canonical DO>>IO order (9b), without altering the grammatical relation between arguments.

Afrikaans

- (9) a. ...dat die gevangene die polisieman 'n medepligtige belowe het
 ...that the prisoner the policeman an accomplice promised has
 SUB IO DO
 "...that the prisoner promised an accomplice to the policeman"
- b. ...dat die gevangene 'n medepligtige die polisieman belowe het
 ...that the prisoner an accomplice the policeman promised has
 SUB DO IO

In example (10), with the verb *vertel* ('tell'), the DO *'n storie* ('a story') is allowed to scramble over the IO *die man* ('the man') (10b). In example (11), with the verb *leen* ('loan'), the DO *geld* ('money') is allowed to scramble over the IO *die vrou* ('the woman') (11b). In example (12), with the verb *gee* ('give'), the DO *'n dokument* ('a document') is allowed to scramble over the IO *die vrou* ('the woman') (12b).

- (10) a. ...dat Piet die man 'n storie vertel het [canonical]
 ...that Peter the man a story told has
 IO DO
 "...that Peter told a story to the man."
- b. ...dat Piet 'n storie die man vertel het [scrambled]
 ...that Peter a story the man told has
 DO IO
- (11) a. ...dat Susan die vrou geld geleen het [canonical]
 ...that Susan the woman money loaned has
 IO DO
 "...that Susan loaned money to the woman."
- b. ...dat Susan geld the vrou geleen het [scrambled]
 ...that Susan money the woman loaned has
 DO IO

- (12) a. ...dat die man die vrou 'n dokument gegee het [canonical]
 ...that the man die woman a document given has
 IO DO
 "...that the man gave a document to the woman"
- b. ...dat die man 'n dokument die vrou gegee het [scrambled]
 ...that the man a document the woman given has
 DO IO

The inversion effect appears to be a clear instance of short-distance scrambling Type 2. Henceforth I will refer to this 'inversion phenomenon' as *scrambling*.

It should be noted that the lack of case morphology in Afrikaans means that alternative orders, when they are licensed, may also have an ambiguous interpretation in the absence of other disambiguating factors. For instance: In (13a) the types of DP involved make it obvious *who* (SUB) [+animate] did *what* (DO) [-animate] to *whom* (IO) [+animate]. *Die skeidsregter* ('the referee') deprived *die span* ('the team') of *die geleentheid* ('the opportunity'), and so the semantic context disambiguates the constituents and even in the scrambled order (13b) the relation between the IO and DO is clear.

(13) *Afrikaans*

- a. ...dat die skeidregter die span die geleentheid ontnem het
 ...that the referee the team the opportunity deprived has
 SUB IO DO
 "...that the referee deprived the team of the opportunity"
- b. ...dat die skeidsregter die geleentheid die span ontnem het
 ...that the referee the opportunity the team deprived has
 SUB DO IO

The relation becomes unclear when both the DO and IO are [+animate], and hence establish a symmetrical relation. In (14a) and (14b) disambiguating between *hul lede* ('their members') and *die polisieman* ('the policeman') becomes entirely context

dependent. But, in both orders, both a theme>goal and goal>theme interpretation is available, and both orders, given either context, are acceptable.

(14) *Afrikaans*

- a ...dat die bende hul lede die polisieman belowe het
 ...that the gang their members the policeman promised has
 IO/DO IO/DO
 “That the gang promised their members to the policeman”/
 “That the gang promised the policeman to their members”
- b. ...dat die bende die polisieman hul lede belowe het
 ...that the gang the policeman their members promised has
 IO/DO IO/DO

1.3. Scrambling conditions

In Afrikaans, the possibility for scrambling, as exemplified by Flexible DOCs, relies on two crucial factors: (1) a specific sentence format, and (2), a particular set of verbs.

1.3.1. Sentence format

Afrikaans scrambling only appears to be possible within a specific sentence format as represented by (15). Scrambling is only possible in embedded clauses with an overt C element and a sentence-final Verb cluster (or a sentence-final V in the absence of V_{AUX} (i.e. all verbs must be sentence-final)).

- (15) C SUB <IO, DO> V_c

Scrambling is not possible in main clauses, embedded clauses without an overt C-element, or any construction where the verbal elements are not sentence final.

Main clauses do not allow altering the canonical order of the sentence objects without inverting the grammatical roles. In example (16), scrambling the DO *’n medepligtige* (‘an accomplice’) over the IO *die polisieman* (‘the policeman’) is not possible (16b).

(16) Afrikaans

- | | | | | | |
|----|--|------------|--|--|--------------------|
| a. | Die gevangene
The prisoner
SUB | het
has | die polisieman
the policeman
IO | 'n medepligtige
an accomplice
DO | belowe
promised |
| | "The prisoner promised an accomplice to the policeman" | | | | |
| b. | *Die gevangene
The prisoner
SUB | het
has | 'n medepligtige
an accomplice
DO | die polisieman
die policeman
IO | belowe
promised |

In example (17), scrambling the DO *die kasteel* ('the castle') over the IO *die mense* ('the people') (17b) is not possible.

(17) Afrikaans

- | | | | |
|----|---|---------------------------------|---------------------------------|
| a. | Die man wys
The man shows | die mense
the people
IO | die kasteel
the castle
DO |
| | "The man showed the castle to the people" | | |
| b. | *Die man wys
The man shows | die kasteel
the castle
DO | die mense
the people
IO |

Embedded clauses without an overt C element are identical in this respect to main clauses. In example (18) a main clause *Ek hoor...* ('I hear...') introduces the canonical order (18a) and its (ungrammatical) scrambled order (18b). The DO *die televisie* ('the television') cannot be scrambled across the IO *die vrou* ('the woman'). In contrast, when the embedded clause is verb-final, scrambling is possible (18d).

(18) Ek hoor...
I hear (that)...

- | | | | | | | |
|----|---|------------|---------------------------------|---------------------------------------|-----------------|-------------|
| a. | ...die man
...the man
SUB | het
has | die vrou
the woman
IO | die televisie
the television
DO | gestuur
sent | [canonical] |
| | "...the man has sent the television to the woman" | | | | | |
| b. | *...die man
...the man | het
has | die televisie
the television | die vrou
the woman | gestuur
sent | [scrambled] |

- | | | | | | | | | |
|----|--|---------|----------------|----------------|---------|-----|-------------|--|
| | | SUB | | DO | | IO | | |
| c. | ...dat | die man | die vrou | die televisie | gestuur | het | [canonical] | |
| | ...that | the man | the woman | the television | sent | has | | |
| | | SUB | | IO | | DO | | |
| | “...that the man has sent the television to the woman” | | | | | | | |
| d. | ...dat | die man | die televisie | die vrou | gestuur | het | [scrambled] | |
| | ...that | the man | the television | the woman | sent | has | | |
| | | SUB | | DO | | IO | | |

All verbs must appear sentence finally. A verb in V2 position blocks scrambling. Modern Spoken Afrikaans allows V2 in embedded clauses with an overt C element (Biberauer, 2001). In example (19) the auxiliary verb *sal* ('will') appears in V2 position even though there is an overt C element.

- (19) Ek dink dat jy sal die boek baie geniet
 I think that you will the book much enjoy
 “I think that you will enjoy the book” (Biberauer, 2001:38)

A ditransitive construction of this kind, in my judgment, allows the canonical order SUB>>IO>>DO (20a), but, as with main clauses, does not allow the DO *die geld* ('the money') to appear before the IO *Piet* ('Peter'), (20b). However, when the auxiliary appears sentence-final, scrambling is possible, (20c):

(20) *Afrikaans*

- | | | | | | | | |
|----|--|----------|---------------|-----------|----------|-------------|-------------|
| a. | Ek dink | dat sy | het Piet | die geld | belowe | | |
| | I think | that she | has Peter | the money | promised | | |
| | | | IO | DO | | | |
| | “I think that she has promised the money to Peter” | | | | | | |
| b. | *Ek dink | dat sy | het die geld | Piet | belowe | [scrambled] | |
| | I think | that she | has the money | Peter | promised | | |
| | | | DO | IO | | | |
| c. | Ek dink | dat sy | die geld | Piet | belowe | het | [scrambled] |
| | I think | that she | the money | Peter | promised | has | |
| | | | DO | IO | | | |

To conclude, Afrikaans allows strong scrambling only within the sentence format (15). I refer to these structures as Flexible DOCs. Afrikaans blocks (strong) scrambling when V-raising occurs.

1.3.2. Verbs

The other crucial factor that affects the possibility of strong scrambling in Afrikaans is the type of verb: Only certain verbs allow their object arguments to scramble, i.e. the possibility of scrambling is limited to certain verbs. As I showed in section 2.2.2., strong scrambling in Afrikaans appears to be possible with lexically ditransitive verbs such as *gee* ('give'), *belowe* ('promise'), *wys* ('show'), *neem* ('take (to)'), *ontneem* ('deprive'), *vertel* ('tell/'said (to)'), *leen* ('loan'), etc., i.e. verbs whose lexical semantics licenses two internal arguments (compare examples (9)-(14) above). In contrast, the Rigid DOCs discussed in section 1.2.1., which did not allow scrambling, were based on verbs such as *bou* ('build'), *verf* ('paint'), *bak* ('bake'), *skets* ('sketch'), etc., which are lexically transitive, but which can appear in constructions where an optional (benefactive) indirect object is added to derive a DOC (compare examples (5)-(7) above).

Interestingly, however, not all DOCs derived from verbs which are lexically transitive are Rigid DOCs. The possibility of strong scrambling is also available with a class of (usually) transitive verbs with a strong (GOAL) directionality or transfer-of-possession interpretation, like *skop* ('kick'), *gooi* ('throw'), *skuif* ('shift/move'), *skiet* ('shoot (to)'). These verbs can also appear in DOCs with an optional indirect object, but in contrast to Rigid DOCs, the resulting DOCs are flexible. In the following I refer to these constructions as 'special ditransitives', as they behave just like lexically ditransitive verbs discussed in section 2.2.1.

To illustrate: In example (21), with the verb *skop* ('kick'), the DO *die bal* ('the ball') is allowed to scramble over the optional IO *die speler* ('the player') (21b). In example (22), with the verb *gooi* ('throw'), the DO *die sleutels* ('the keys') is allowed to scramble over the IO *haar man* ('her man') (22b). In example (23), with the verb *skuif* ('move/shift'), the DO *die produk* ('the product'), is allowed to scramble over the IO *die klient* ('the client')

(23b). In example (24), with the verb *rol* ('roll (to)'), the DO *die appel* ('the apple') is allowed to scramble over the IO *die gevangene* ('the prisoner') (24b).

- (21) a. ...dat hy die speler die bal gekop het [canonical]
 ...that he die player the ball kicked has
 IO DO
 "...that he kicked the ball to the player"
- b. ...dat hy die bal die speler gekop het [scrambled]
 ...that he the ball the player kicked has
 DO IO
- (22) a. ...dat sy haar man die sleutels gegooi het [canonical]
 ...that she her husband the keys thrown has
 IO DO
 "...that she threw the keys to her husband"
- b. ...dat sy die sleutels haar man gegooi het [scrambled]
 ...that she the keys her man thrown has
 DO IO
- (23) a. ...dat sy die klient die produk geskuif het [canonical]
 ...that she the client the product shifted has
 IO DO
 "...that she shifted the product to the client"
- b. ...dat sy die produk die klient geskuif het [scrambled]
 ...dat she the product the client shifted has
 DO IO
- (24) a. ...dat sy die gevangene die appel gerol het [canonical]
 ...that she the prisoner the apple rolled has
 IO DO
 "...that she rolled the apple to the prisoner"
- b. ...dat sy die appel die gevangene gerol het [scrambled]
 ...that she the apple the prisoner rolled has
 DO IO

In sum, Afrikaans allows strong scrambling Type 2 with two classes of DOCs in embedded clauses with verb-final word order: lexically ditransitive, and 'special' ditransitive verbs (= transitive verbs which appear in the syntax with an optional goal IO)

In contrast, DOCs that take an optional IO argument do not allow scrambling. In the following section I present an analysis of this empirical observation.

2. Analysis

2.1. Core-arguments

Flexible DOCs and embedded Rigid DOCs share the same sentence format, but Rigid DOCs, unlike Flexible DOCs, do not allow scrambling. I have noted that the difference appears to be related to the type of verb involved. Only a particular type of verb allows the possibility for scrambling. I therefore put forward and defend the following hypothesis for Afrikaans:

Hypothesis: Only verbs that select two 'core' internal-arguments can scramble.

An argument is a 'core' argument if the argument is *obligatory*. Obligatory arguments cannot be left out of a sentence without resulting in ungrammaticality. Helbig (1992) proposes this straight-forward "elimination test" to identify obligatory arguments (Zeller, 2001a: 3). However, I will use a slightly modified version of the elimination test to define core-arguments: Core-arguments do not always have to be overt, but core-arguments are always entailed by the lexical semantics of the verb. I illustrate this point below in examples (25) and (26).

Verbs like *belowe* ('promise'), *gee* ('give'), *leen* ('loan'), etc. select two core-arguments (whether they are overt or not). Verbs like *bou* ('build'), *verf* ('paint'), *bak* ('bake'), etc. select only one core argument. *Belowe*-type verbs allow scrambling while *bou*-type verbs do not.

Example (25a)-(25d) illustrate that the verbs *belowe/gee/leen* involve two core-arguments (indicated in square brackets): A DO – the thing that is promised/given/loaned, and an IO – to whom the thing is promised/given/loaned, whether overtly realized or not. The appropriate answer to the question "What do you

promise/give/loan?” (25cb) must be (25d) where both core-arguments are overtly realized.

- (25)
- a. Ek belowe/gee/leen [IO] [DO]
I promise/give/loan
 - b. *Wat belowe/gee/leen jy?*
“What do you promise/give/loan?”
 - c. *Ek belowe die geld/?Ek gee die geld/*Ek leen die geld
I promise the money/I give the money/I loan the money
 - d. Ek belowe/gee/leen die man die geld.
 IO DO

Example (26a)-(26c) illustrate that the verbs *bou/verf/bak* involve one core argument only (indicated in square brackets): A DO (i.e. the thing that is built/painted/baked). Any additional internal arguments are non-core. The IO *die man* (‘the man’) is not a core-argument, because it is not entailed by the verbs *bou/verf/bak*. It is not necessary that the DO is built/painted/baked to-the-possession-of the IO (26d). Hence an appropriate and sufficient answer to the question “What are you building/painting/baking?” (26b) is (26c), where the (one) core argument is overtly realized.

- (26)
- a. Ek bou/verf/bak [DO]
I build/paint/bake
 - b. *Wat bou/verf/bak jy?*
What are you building/painting/baking?
 - c. Ek bou die huis/Ek verf die doek/Ek bak die koek
I build the house/I paint the canvas/I bake the cake
 DO DO DO
 - d. Ek bou/verf/bak (die man) die huis/doek/koek
I build/paint/bake (the man) the house/canvas/cake
 (IO) DO
“I build the house (for the man)”/ “I paint the canvas (for the man)”/ “I bake the cake (for the man)”

Example (27) shows that *belowe* allows scrambling and example (28) shows that *bou* does not. In general, it appears, scrambling of the DO across an IO is not possible if the IO is not a core-argument:

(27) *Belowe*

- a. ...dat ek die man die geld belowe het [canonical]
...that I the man the money promised have
IO DO
“...that I promised the money to the man”
- b. ...dat ek die geld die man belowe het [scrambled]
...that I the money the man promised have
DO IO

(28) *Bou*

- a. ...dat ek die man die huis gebou het [canonical]
...that I the man the house built have
IO DO
“...that I built the house for the man (to have)”
- b. *...dat ek die huis die man gebou het [scrambled]
...that I the house the man built have
DO IO

The contrast between (29) and (30) further illustrates that the possibility of scrambling depends on the status of the verb's IO-argument (i.e. as core, or non-core). The verb *leen* ('loan') requires a thing-that-is-loaned (DO) and an entity-that-is-loaned-to (IO), while a verb like *braai* ('braai'/'barbeque') only requires a thing-that-is-braaiied (DO). Consequently, *leen* ('loan') allows scrambling (29b), while *braai* ('braai'/'barbeque') does not (30b):

(29) *Leen*

- a. ...dat ek die man die hammer geleen het [canonical]
...that I the man the hammer loaned have
IO DO
“...that I loaned the hammer to the man”
- b. ...dat ek die hammer die man geleen het [scrambled]
...that I the hammer the man loaned have
DO IO

(30) *Braai*

- a. ...dat ek die mans die vark gebraai het [canonical]
...that I the men the pig barbequed have
IO DO
“...that I barbequed the pig for the men”
- b. *...dat ek die vark die mans gebraai het [scrambled]
...that I the pig the men barbequed have
DO IO

Special ditransitives present a problem for this generalization. These verbs select an optional IO. In embedded DOCs, special ditransitives, like ditransitives, allow scrambling. However, special ditransitives involve transitive verbs and, by my logic, only one core argument. I assume that there is a structural similarity between ditransitive verbs and special ditransitives. I propose that special ditransitives are complex verbal predicates which also select two core (internal) arguments. I explore this option in section 2.2.1.

2.2. The syntax of DOCs

The following section proposes that the *mechanism* setting Flexible- and embedded Rigid DOCs apart. I propose that Rigid DOCs are structured like illustrated in example (31). The VP selects one internal core argument ‘DO’. A functional head ‘F’ selects VP and introduces the external non-core argument ‘IO’. Rigid DOCs are associated with transitive verbs, and I assume that transitive verbs have only one VP-internal argument.

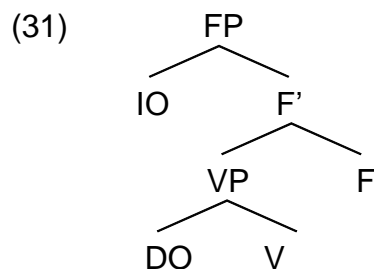

I propose that Flexible DOCs are like (32). The VP selects two internal core-arguments ‘IO’ and ‘DO’. A functional head ‘F’ selects VP. Flexible DOCs are associated with

ditransitives and special ditransitives, and I propose that these verbs have two VP-internal core-arguments.

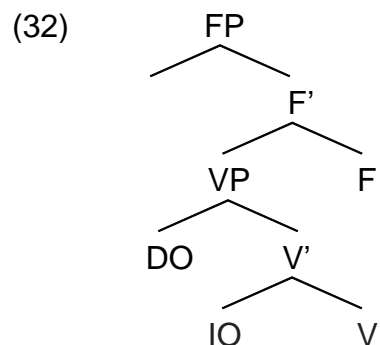

I propose that the distinction between Rigid- and Flexible DOCs can be approached as the interaction between:

- (1) An (always present) VP-external functional projection 'FP' with a head 'F' containing an [EPP] feature that requires a DP-object in [Spec, F].
- (2) The options made available to Probe F (see Chapter 2, pp. 13-14) to satisfy its strong formal feature. Option A: Merge an appropriate object DP from the Numeration in [Spec, F], or Option B: Move an appropriate VP-internal DP into [Spec, F].

The proposed structure is represented in (33).

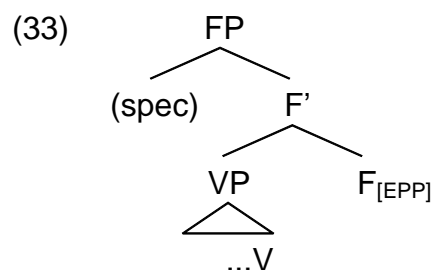

I propose that Flexible DOCs and embedded Rigid DOCs present different options to F. A Rigid DOC includes a non-core argument in the Numeration, which can be Merged in [Spec, F]. Economy rules out raising. A Flexible DOCs includes two core-arguments in VP (and no (non-core) arguments in the Numeration). Flexible DOCs require raising to [Spec, F]. I propose the nature of this raising operation can explain the optionality exhibited by Flexible DOCs.

2.2.1 Rigid DOCs

Rigid DOCs involve transitive verbs which select one core (internal) argument. The IO in these constructions is a non-core argument. VP selects one core argument 'DO'. A functional head F with an EPP feature selects VP. In a transitive sentence F requires movement of DO into [Spec, F] (34). In a DOC construction IO is introduced by F in [Spec, F] from the Numeration (35). IO is always Merged in a position higher than DO.

- (34) a.
-
- ```

graph TD
 F --> DO1[DO]
 F --> F_prime[F']
 F_prime --> VP
 F_prime --> F
 VP --> DO2[DO]
 VP --> V
 DO2 -.-> DO1

```
- b. ...dat sy [FP die koek [VP ~~die koek~~ bak]]  
 ...that she the cake bake  
 DO DO
- “that she baked the cake for the woman”

- (35) a.
- 
- ```

graph TD
    F --> IO
    F --> F_prime[F']
    F_prime --> VP
    F_prime --> F
    VP --> DO
    VP --> V
  
```
- b. ...dat sy [FP die vrou [VP die koek bak]]
 ...that she the woman the cake bake

IO DO
“that she baked the cake”

2.2.2.Flexible DOCs

Flexible DOCs allow a canonical IO>>DO ordering or a scrambled DO>>IO ordering. I deal with the problem of optionality, presented by Flexible DOCs, by relying on the idea of equidistance (36) and minimal domains (37). Optionality, in this analysis, means that, given a specific Numeration, there are two ways of building the derivation that are equally ‘costly’. In other words, assuming that scrambling structures are driven by a strong formal feature (as all (overt) movement must be in a minimalist framework), optionality does not become a problem of ‘move or do not move’, but instead arises as a result of ‘move x OR move y’ where ‘x’ and ‘y’ are two suitable elements.

(36) Equidistance:

“ γ and β are equidistant from α if γ and β are in the same Minimal Domain”
(Chomsky, 1995: 356).

According to (36), two elements are equidistant from another element if these two elements are in the same minimal domain.

(37) Minimal Domain

“The Minimal Domain of α , or $\text{MinD}(\alpha)$, is the set of categories immediately contained or immediately dominated by projections of the head α , excluding α .”
(Hornstein et al., 2005:149; Chomsky, 1995: 179)

The minimal domain of X, or $\text{MinD}(X)$, is the complement (Compl) of X and the specifier(s) of X.

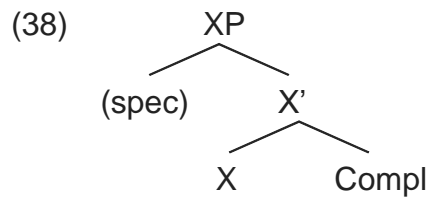

Now let it be assumed that a functional head F selects XP. XP contains two arguments OBJ₁ and OBJ₂ (39)

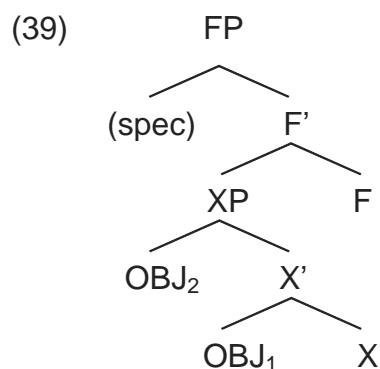

The minimal domain of X includes its complement OBJ₁ and its specifier OBJ₂. Let it be assumed that F has an EPP feature that requires movement of a suitable element to [Spec, F] (i.e. an element with a [D] feature). The arguments of XP, OBJ₁ and OBJ₂ both qualify as suitable elements and both fall within F's search-space (i.e. F's c-command domain). Economy requires, usually, that the 'closest' suitable element in F's c-command domain must move, where 'closeness' is understood in terms of c-command. Technically OBJ₂ is *closer* to F than OBJ₁ since F c-commands OBJ₂ and OBJ₂ c-commands OBJ₁. However, c-command becomes irrelevant in this instance as both OBJ₁ and OBJ₂ are in the same minimal-domain (i.e. the minimal domain of X), and hence they are equidistant from F's perspective. Either element can move to satisfy F's EPP feature, at the same 'cost'.

I am proposing that in Flexible DOCs, the XP in (39) is the VP, and that ditransitives and special ditransitives include two VP-internal objects that are both suitable as elements for the EPP feature on F (see example (40a)). When two objects are available, the functional head selecting the VP can move either one to [Spec, F] (see examples (40b) and (40c)).

- (40) a.
-
- b. ...dat sy [_{FP} die geleentheid [_{VP} die man ~~die geleentheid~~ ontnem het]]
 ...that she the opportunity the man deprived has
 DO IO ~~DO~~
- “...that she deprived the man of the opportunity”
- c. ...dat sy [_{FP} die man [_{VP} ~~die man~~ die geleentheid ontnem het]]
 ...that she the man the opportunity deprived has
 IO ~~IO~~ DO

What about the IO of special ditransitives? Special ditransitives are verbs that are lexically transitive, but which optionally add a non-core IO. As mentioned before, I propose that special ditransitives are complex verbal predicates which also select two core (internal) arguments. I will assume that the additional core argument of special ditransitives is introduced VP-internally by means of a ‘directional’ prepositional particle (‘directional’ in the sense that the proposition indicates a change of possession/location). This particle, which can be phonologically null in Afrikaans, incorporates into V and derives a complex verbal predicate with two internal core-arguments (see Zeller, 2001a, 2001b on complex predicate formation with particles; see Le Roux, 1988: 229 on particle verbs in Afrikaans):

(41)

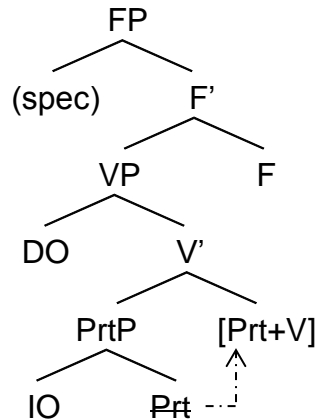

According to the complex-predicate analysis illustrated in (41), special ditransitives are similar to lexical ditransitives in that both internal arguments are introduced as core-arguments inside the VP. As was shown in section 1.3.2., special ditransitives also pattern with lexical ditransitives in allowing scrambling of the DP across the IO. This correlation between scrambling and 'core argument status' is correctly captured by the hypothesis put forward above.

There is some evidence from Dutch for a particle analysis. Zwart (1993: 132) discusses the freer placement flexibility of weak pronouns and points out that a sentence like (42) can be ordered IO>>DO (42a) or DO>>IO (42b), if (and only if) the verb contains a particle:

(42) *Dutch*

- a. dat Jan Marie het boek terug gegeven heeft
that John Mary the book back given has
IO DO
“...that John gave Mary the book back”

- b. dat Jan het boek Marie terug gegeven heeft.
that John the book Mary back given has
DO IO

(Zwart, 1993: 132)

Special ditransitives in Afrikaans can combine with a ‘directional’ prepositional particle. In example (43), the Prt *terug* (‘back (to)’) combines with the transitive verbs *skop*

(‘kick’) or *gooi* (‘throw’), to form the complex *terug gegooi* (‘threw back (to)’). The DO *die bal* (‘the ball’) and IO *Marie* (‘Mary’) are free to scramble (43b). The same is possible in example (44), where the Prt *nader* (‘closer (to)’ has combined with the verbs *skuif* (‘move(to)’) or *stoot* (‘push(to)’), and the DO *die sleutels* (‘the keys’) and IO *die vrou* (‘the woman’) are free to scramble (44b).

(43) *Afrikaans*

a. ...dat Jan Marie die bal terug geskop/gegooi het
 ...that John Mary the ball back kicked/threw has
 IO DO Prt
 “...that John kicked/threw the ball back to Mary”

b. ...dat Jan die bal Marie terug geskop/gegooi het
 ...that John the ball Marie back kicked/threw has
 DO IO Prt

(44) a. ...dat die man die vrou die sleutels nader geskuif/gestoot het
 ...that the man the woman the keys closer moved/pushed has
 IO DO Prt
 “...that the man moved/pushed the keys closer to the woman”

b. ...dat die man die sleutels die vrou nader geskuif/gestoot het
 ...that the man the keys the woman closer moved/pushed has
 DO IO Prt

In Afrikaans embedded clauses it is not possible to separate Prt from V without resulting in ungrammaticality. In example (45), with the Prt *nader* (‘closer(to)’), it is not possible to intervene between the Prt and the verb-complex *geskuif het* (‘moved has’) with the DO *die koppie* (‘the cup’) (45b).

(45) a. ...dat ek die man die koppie nader geskuif het
 ...that I the man the cup closer moved have
 IO DO Prt V V_{AUX}
 “I pushed the cup closer to the man”

b. *...dat ek die man nader die koppie geskuif het
 ...that I the man closer the cup moved have
 IO Prt DO V V_{AUX}

In the case of special ditransitives, both object arguments do not strictly fall within the same minimal domain, as I am proposing that a Prt head introduces IO into VP (40)⁶. However, I have assumed that Prt incorporates with V forming a complex predicate (in the sense of Chomsky 1995). Within this complex both objects fall within the same minimal domain, and Prt does not present an obstacle to movement. In this way special ditransitives are allowed the same flexibility as ditransitives.

2.3. Applicatives

What is the nature of FP? In this section I propose that FP might be an Applicative Phrase.

“Applicative” generally refers to specific morphemes that license an extra non-core argument as part of a verb’s argument structure (Jeong, 2007: 2-3). In example (46) below from Chaga, the applicative marker *í* licenses the non-core argument *m-kà* (‘wife’).

Chaga

(46) N-ä-í-lyì-í-à m-kà k-élyá
 FOC-1SG-PRES-eat-APPL-FV 1-wife 7-food

“He is eating food for his wife” (Pylkkänen, 2008:12).

A transitive (base) verb, thus, can be ‘transformed’ into a ditransitive verb by an applicative marker. However, applicatives do not have to be overt (cross-linguistically) and may also be used to refer to IO in ditransitive sentences (Jeong, 2007: 2-3).

One possibility is to treat FP as an Applicative phrase (AppIP) headed by a (silent) head (AppI). FP resembles Pylkkänen’s ‘high’ applicative construction (see Pylkkänen, 2008:12). The distinction between Rigid and Flexible DOCs, in this sense, can be made in terms of Marantz’ (1993) ‘thematic’ and ‘raising’ (or ‘expletive’) applicatives (Marantz,

⁶ The difference between PPs and special ditransitives, is that the particle in special ditransitives combines with the verb to form a complex verbal predicate.

1993; Georgala, Waltraud & Whitman, 2008: 181). Thematic applicatives correspond to embedded Rigid DOCs- they generate a VP-external non-core argument in [Spec, Appl] (47). In contrast, Raising applicatives correspond to Flexible DOCs- they move an object out of VP to [Spec, Appl] (48). Thematic applicatives introduce an extra argument to the structure, while Raising Applicatives license a DP inside the VP (Georgala, Waltraud & Whitman, 2008: 181).

(47) [_{APPLP} DP_{IO} [_{APPL'} APPL [_{VP} V DP_{DO}]]]

(48) [_{APPLP} DP_{IO} [_{APPL'} APPL [_{VP} DP_{IO} [_{V'} V DP_{DO}]]]

I illustrate how the derivation of, firstly, a Rigid DOC proceeds, and secondly, how a Flexible DOC is derived in Afrikaans.

Rigid DOC

(49) ...dat die vrou die man die koek gebak het
 ...that the woman the man the cake baked has
 C SUB IO DO V V_{AUX}
 "...that she baked the man the cake"

According to my analysis sketched above, a Rigid DOC like (49), with the verb *bak* ('bake'), DO *die koek* ('the cake'), IO *die man* ('the man'), SUB *die vrou* ('the woman'), overt C *dat* ('that'), and V_{AUX} *het* ('has'), is derived in the following way:

1. The lexical (transitive) V selects one internal core argument DP_{DO} to form VP
2. A phonologically null Applicative head (Appl) selects VP
3. Appl has an EPP feature that requires a suitable element in [Spec, Appl]
4. Appl introduces DP_{IO} in [Spec, Appl], and eliminates the EPP feature to form ApplP.
5. A phonologically null light verb v selects ApplP and introduces DP_{SUB} to form vP
6. T selects vP. T has an EPP feature that requires a suitable element in [Spec, T]
7. DP_{SUB} is moved into [Spec, T]

8. A phonologically realized C selects TP to form CP

The diagram in (50) represents the structure corresponding to this derivation.

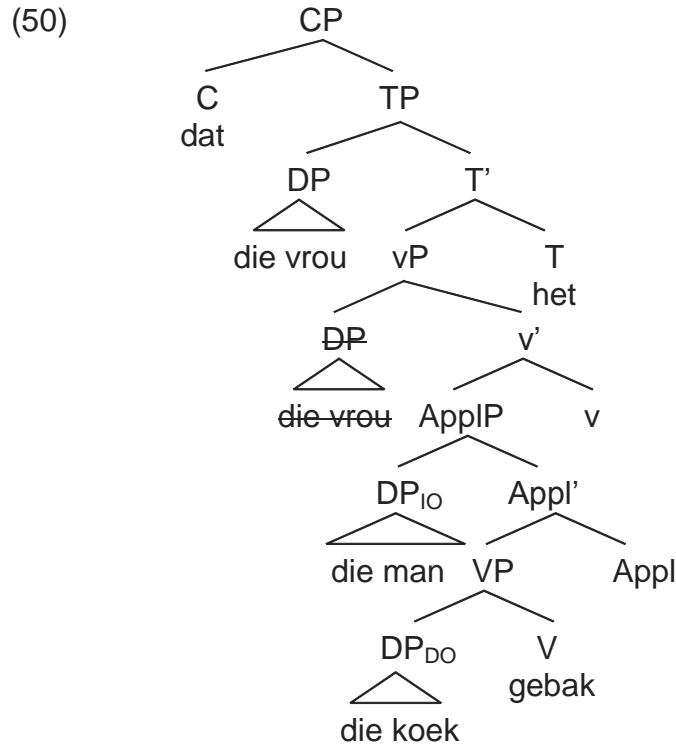

I assume that structural case can be checked (under Agree) by Appl (dative), v (accusative), and T (nominative). Appl checks structural case on the IO *die man* ('the man') [dative], v checks structural case on the DO *die koek* ('the cake') [accusative], and T checks structural case on the SUB *die vrou* ('the woman') [nominative].

Flexible DOC

- (51) a. ...dat die vrou die man die huis gewys het [canonical]
 ...that the woman the man the house showed has
 C SUB IO DO V V_{AUX}
 "...that the woman showed the man the house"
- b. ...dat die vrou die huis die man gewys het [scrambled]
 ...that the woman the house the man showed has

C SUB DO IO V V_{AUX}

In example (51), with the verb *wys* ('show'), DO *die huis* ('the house'), IO *die man* ('the man'), SUB *die vrou* ('the woman'), overt C *dat* ('that'), and V_{AUX} *het* ('has'), the sentence can have two equally costly outcomes, which is determined in step 4. Either (51a) results or (51b) results.

1. The lexical (transitive) V selects two internal arguments, DP_{DO} and DP_{IO}, to form VP
2. A phonologically Applicative head (Appl) selects VP
3. Appl has an EPP feature that requires a suitable element in [Spec, Appl]
4. At this point Appl can select either DP_{IO} or DP_{DO} to eliminate its EPP feature. In the case of (51a), Appl selects DP_{IO} and moves it to [Spec, Appl] to form ApplP. In the scrambled example (51b), Appl has attracted DP_{DO}.
5. A phonologically null light verb v selects ApplP and introduces DP_{SUB} to form vP
6. T selects vP. T has an EPP feature that requires a suitable element in [Spec, T]
7. DP_{SUB} is moved into [Spec, T]
8. A phonologically realized C selects TP to form CP

Example (52) represents the structure, where the DP in [Spec, Appl] could be either the IO or the DO.

(52)

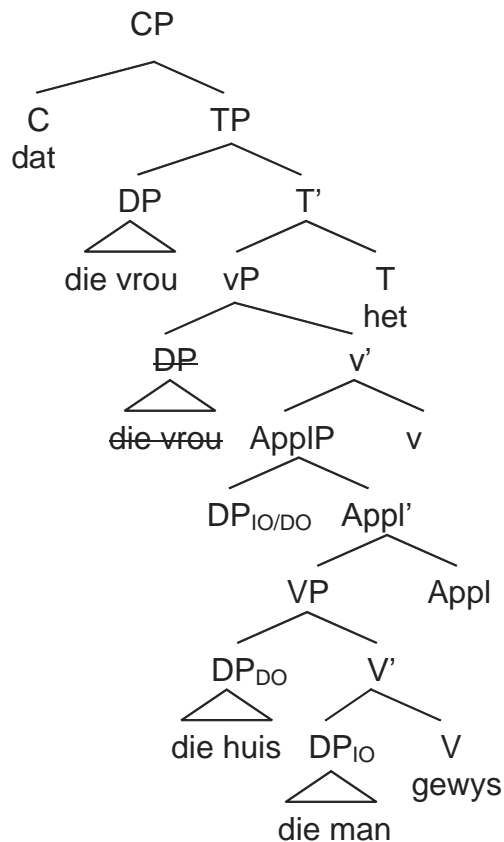

3. Conclusion

The existence of strong scrambling in Afrikaans has not received any attention. However, there appear to be constructions in Afrikaans that do allow what I have termed short-distance scrambling Type 2, which falls under the definition of strong scrambling I have developed in Chapter 3. Given the assumption thus far, strong scrambling should not be an option for a language that does not mark morphological case on its object DPs. These structures and their analysis require much more work. But it is clear that there are two types of embedded DOCs in Afrikaans. One type allows scrambling (Flexible DOCs) and the other blocks scrambling (Rigid DOCs). The possibility to scramble, in one regard, is dependent on whether the sentence involves a verb that falls under a set of specific ditransitive (and special ditransitive) verbs. But I have also demonstrated that, apart from the type of verb, another restriction on scrambling is V-raising. Scrambling in Afrikaans is blocked if all verbal elements are not sentence final. This particular property of Afrikaans scrambling constructions is

particularly puzzling, given that V-raising is traditionally associated with greater argument flexibility (at least this is the case in MSc and Icelandic (Holmberg's generalization)).

Chapter 5

Conclusion

In this chapter I reiterate the most important points discussed in this thesis about Afrikaans and briefly examine an interesting contrast between Afrikaans and Icelandic.

I have distinguished different types of scrambling, broadly (1) Clause-internal scrambling, and (2) Clause-external scrambling. Clause-internal scrambling, or ‘MF scrambling’, includes short-distance scrambling (Type 1 and Type 2), and medium-distance scrambling. Clause-external scrambling refers to long-distance movement operations not available in German, Dutch, or Afrikaans.

German-type MF (i.e. clause-internal) scrambling has been associated with two grammatical prerequisites: (1) A rich overt case morphology, and (2) an OV base-order.

Afrikaans and Dutch are typically known as weak scrambling languages, allowing only argument-order preserving operations in the MF. Dutch and Afrikaans only allow argument permutation when arguments can be identified by overt case marking, which in the case of full DPs, seems to require the use of prepositions. This observation seems to reinforce the idea that a rich overt case morphology is a necessary condition for argument-permuting scrambling (i.e. ‘strong’ scrambling).

However, in Chapter 4, I identify certain double object constructions in Afrikaans that challenge this requirement: Flexible DOCs. Certain verbs in Afrikaans allow strong scrambling of their objects in finite embedded clauses with an overt C element. These objects are not marked for case, and yet are able to (optionally) appear in a non-canonical order.

I have also pointed out that this type of construction is only available in a certain sentence format with certain verbs. Strong scrambling in Afrikaans requires a lexically-

ditransitive or special ditransitive verb (and is not possible with a class of derived ditransitive verbs with non-core IOs). Strong scrambling also requires that all verbal elements in the clause are sentence-final. Only Afrikaans embedded clauses with an overt C element constitute the required sentence format for scrambling. Scrambling is not possible in main clauses, and scrambling is not possible in embedded clauses without an overt C element. Afrikaans blocks (strong) scrambling when V-raising (V2) applies, i.e. in main clauses, and in embedded clauses that allow V2. Afrikaans contrasts with Mainland-Scandinavian (MSc) object shift languages that can only scramble when V-raising occurs (and must do so obligatorily if V2 applies). This topic requires further attention, and I will leave it for future research.

I have proposed that, given the appropriate sentence format, the types of verbs that are associated with strong scrambling, and those that are not, can be distinguished in terms of argument selection. The verbs that I have correlated with scrambling (i.e. ditransitive verbs and special ditransitives) select two internal core-arguments, and verbs that do not allow scrambling select only one internal core-argument. I have proposed the following structural representations for DOCs that allow scrambling (i.e. 'Flexible DOCs') (1a); and DOCs that do not allow scrambling (i.e. 'Rigid DOCs') (1b):

- (1) a. Flexible DOCs
 $[_{VP} [SUB] [_V [V]_{FP} [IO/DO] [_F [F] [_{VP} <IO DO> V]]]]]$

- b. Rigid DOCs
 $[_{VP} [SUB] [_V [V]_{FP} [IO] [_F [F] [_{VP} DO V]]]]]$

I have proposed that in Afrikaans DOCs F always selects VP. F has an EPP feature that requires a suitable argument in its specifier position. The EPP feature of F can be checked either by merging an appropriate argument from the Numeration, or by raising an appropriate argument to [Spec, F]. In a DOC construction based on a transitive verb, VP contains only one argument, and F is able to merge the extra non-core argument from the Numeration. In a DOC with a ditransitive verb, both object arguments are generated VP-internally, and Probe F selects one argument from VP. I have argued that

both object arguments are in the minimal domain of the verb and hence either argument can be attracted by F to check its EPP feature. I have attempted to show that the contrast between Rigid and Flexible DOCs can be explained by assuming that different types of ditransitive constructions are associated with different structural realizations. As noted before, some ditransitive verb constructions allow strong scrambling, something which is not expected in a weak scrambling language, especially in a language like Afrikaans that has a very lean case-morphology.

There is some room for future research regarding the interaction between argument placement flexibility and V-raising. As mentioned before, Afrikaans contrasts with the MSc object shift languages in not allowing scrambling when V-raising applies. There is some interesting common ground between Afrikaans and Icelandic regarding the role of overt case marking, type of verb, and verb placement. Icelandic has a rich case morphology (unlike Afrikaans), but Icelandic is not considered a strong scrambling language (presumably because it is associated with a VO base-order (and not the required OV base-order). However, Icelandic does allow object shift. The object shift that Icelandic exhibits does not look like the kind of object shift usually attributed to MSc languages (see Chapter 3): Icelandic allows full definite DPs (and not only pronouns) to *optionally* (not obligatorily) undergo object shift. In example (2), the DO *þessa bók* (this book') may stay inside VP (NEG>>DO) (2a), but it may also exit the VP, giving rise to the word order DO>>NEG (2b) (assuming that NEG marks the VP boundary). In this respect, Icelandic object shift looks a lot like Afrikaans weak scrambling (Diesing 1997; Thráinsson, 2001):

(2) *Icelandic*

- | | | | | | | |
|----|------------------|------------------|----------------|------------------------------|---------------------------------|---------------------------------|
| a. | Af hverju
Why | las
read
V | Pétur
Peter | aldrei
never
NEG | [_{VP} las þessa bók]? | this book
DO |
| b. | Af hverju
Why | las
read
V | Pétur
Peter | þessa bók
this book
DO | aldrei
never
NEG | [_{VP} las þessa bók]? |

(Vikner 2006: 394)

Unlike languages traditionally classified as weak scrambling languages, such as Afrikaans and Dutch, Icelandic has a rich case morphology, marking morphological case on all DPs (Vikner, 2006: 413). However, unlike Afrikaans and Dutch, but like other MSc languages, Icelandic requires V2 in order to allow object shift.

The interesting parallel between Icelandic and Afrikaans that I would like to highlight at this point concerns 'exceptional order' (Vikner, 2005: 396; Collins & Thráinsson, 1996) that is found in certain ditransitive constructions in Icelandic. The exceptional order has been called an 'inversion phenomenon' (Dehé, 2004: 85-86). This refers to the fact that, with certain verbs, object arguments can be ordered IO>>DO or DO>>IO. In example (3) with the ditransitive verbs *gaf/sýndi/sendir* ('give/showed/sent'), the arguments can appear in the canonical order IO>>DO (3a) or in an inverted order DO>IO (3b):

(3) *Icelandic*

- | | | | | | |
|----|----|------------------|----------|-----------|----------------------------|
| a. | Ég | gaf/sýndi/sendir | honum | bókina. | (unmarked order) |
| | I | gave/showed/sent | him | the-book | |
| | | V | IO | DO | |
| b. | Ég | gaf/sýndi/sendir | bókina | einhverju | bókasafni (inverted order) |
| | I | gave/showed/sent | the-book | some | library |
| | | V | DO | IO | |

(Dehé, 2004: 85-86)

It should be noted here that this does not look like scrambling *per se* (i.e. that the inverted order is derived from the canonical order), but, rather like certain verbs in Icelandic have more than one base-order. This requires further research, and at this point I am only making an observation. Although Afrikaans and Icelandic are under very different restrictions, there are some parallels that merit further research, specifically the type of verb involved, and the placement of the verb. Afrikaans seems much more flexible than Icelandic (despite a leaner case morphology), and unlike Icelandic Afrikaans does not (seemingly) require V-raising to allow weak scrambling (i.e. object shift) operations. However, Afrikaans cannot strongly scramble when V-raising has

applied. The contrast is noteworthy as Afrikaans and Icelandic require, exactly the opposite condition for object inversion. Icelandic must have V-raising, whereas Afrikaans requires that V does not raise.

There is a lot of room for further research on Afrikaans scrambling, and Afrikaans in general within a minimalist framework. This thesis has provided a largely descriptive account of Afrikaans scrambling constructions, and a mechanism that requires independent support. However, Afrikaans does appear to allow exactly the kind of flexibility one would not expect it to have, given the fact that Afrikaans has such a limited case morphology.

Bibliography

Anagnostopoulou, E. (2001). 'Two classes of double object verbs: the role of zero-morphology'. In: M. van Oostendorp & E. Anagnostopoulou (eds), *Progress in Grammar. Articles at the 20th Anniversary of the Comparison of Grammatical Models Group in Tilburg*. Dutch Royal Academy Publications: Electronic book.

Biberauer, T. (2001). *Verb Second in Afrikaans: Is this a Unitary Phenomenon?* Ms Dissertation: University of Cambridge.

Biberauer, T. & Richards, M. (2006). 'True optionality: When the grammar doesn't mind'. In: C. Boeckx (ed), *Minimalist Essays* (pp. 35-67). Amsterdam: John Benjamins Publishing Company.

Bošković, Z. & Takahashi, D. (1998). 'Scrambling and Last Resort'. *Linguistic Inquiry* 29: 3 (pp. 347-366).

Botha, M. & Oosthuizen, J. (2009). 'Die struktuur van die linker-sinsgrens in Afrikaans'. *Stellenbosch Papers in Linguistics, PLUS* 37 (pp. 1-68).

Chocano, G. (2007). *Narrow Syntax and Phonological Form*. Amsterdam: John Benjamins Publishing Company.

Chomsky, N. (1981). *Lectures on Government and Binding*. Dordrecht: Foris.

Chomsky, N., and H. Lasnik. (1993). 'The theory of principles and parameters'. In J. Jacobs, A. von Stechow, W. Sternefeld, & T. Vennemann (eds), *Syntax: An International Handbook of Contemporary Research*, Vol. 1 (pp. 506-569). Berlin: Walter de Gruyter.

Chomsky, N. & Lasnik, H. (1977). 'Filters and Control'. *Linguistic Inquiry* 8 (pp. 425-504).

Chomsky, N. (1993). 'A minimalist program for linguistic theory'. In: K. Hale & S. J. Keyser (eds), *The View from Building 20* (pp. 1-52). Cambridge, MA.: MIT Press.

Chomsky, N. (1995). *The Minimalist Program*. Cambridge, MA.: MIT Press.

Chomsky, N. (2000). 'Minimalist inquiries: The framework'. In: R. Martin, D. Michaels, & J. Uriagereka (eds), *Step by Step: Essays on Minimalist Syntax in Honor of Howard Lasnik*. Cambridge, MA.: MIT Press.

Chomsky, N. (2001). 'Derivation by phase'. In: M. Kenstowicz (ed), *Ken Hale: A Life in Language* (pp. 1-52). Cambridge, MA.: MIT Press.

Chomsky, N. (2005). 'Three factors in language design'. *Linguistic Inquiry* 104 (pp.1–61).

Chomsky, N. (2008). 'On Phases'. In: R. Freidin, P. Carlos & M. Otero (eds), *Foundational Issues in Linguistic Theory: Essays in Honor of Jean-Roger Vergnaud*. Cambridge, MA.: London.

Collins, C. & Höskuldur, T. (1993). 'Object shift in double object constructions and the theory of Case'. In: C. Phillips (ed), *Papers on Case and Agreement II* (pp. 131-174). Cambridge, MA.: *MIT Working Papers in Linguistics* 19.

Collins, C. & H. Thráinsson (1996). 'VP internal structure and object shift in Icelandic'. *Linguistic Inquiry* 27 (pp. 391-444).

Collins, C. (1997). *Local Economy*. Cambridge, MA.: MIT Press.

Conradie, S. (2007). 'The setting of the split-IP parameter in Afrikaans: Evidence from transitive expletive constructions and object shift constructions.' *Stellenbosch Papers in Linguistics PLUS*, Vol 35. (pp. 53-86).

Dehé, N. (2004). 'On the order of objects in Icelandic double object constructions'. *UCL Working Papers in Linguistics* 16 (pp. 85-108).

De Hoop, H. (2003). 'Optionality in Dutch'. In: S. Karimi (ed), *Word Order and Scrambling* (pp. 201-216). Oxford: Blackwell Publishing.

Den Besten, H. (2000). 'The slaves' languages in the Dutch Cape Colony and Afrikaans *vir*'. *Linguistics* 38: 5 (pp. 949-971).

De Stadler, L. (1996). 'The indirect object in Afrikaans'. In W. van Belle (ed), *The Dative* (volume 1) (pp. 251–288). Amsterdam: John Benjamins.

Donaldson, B. (1993). *A Grammar of Afrikaans*. Berlin: Mouton de Gruyter.

Drach, E. (1937). *Grundgedanken der deutschen Satzlehre*. Frankfurt: Diesterweg.

Epstein, S. & Thráinsson, H. (1996). 'Introduction'. In: W. Abraham, S. Epstein, H. Thráinsson, & J.W. Zwart (eds), *Minimal Ideas: Syntactic Studies in the Minimalist Framework*. Amsterdam: John Benjamins Publishing Company.

Fanselow, G. (2001). 'Features, θ -roles, and free constituent order'. *Linguistic Inquiry* 32:3 (pp. 405-437).

Fanselow, G. & Lenertová, D. (2011). 'Left peripheral focus: mismatches between syntax and information structure'. *Natural Language and Linguistic Theory* 29 (pp. 169-209).

- Fukui, N. (1993). 'Parameters and optionality'. *Linguistic Inquiry* 24 (pp. 399-420).
- Georgala, E., Waltraud, P. & Whitman, J. (2008). 'Expletive and Thematic Applicatives'. In: C.B. Chang & H. J. Haynie (eds), *Proceedings of the 26th West Coast Conference on Formal Linguistics (WCCFL 26)* (pp.181-189). Somerville, MA: Cascadilla Proceedings Project.
- Grewendorf, G. (1992). 'German — A Grammatical Sketch'. *Sprachwissenschaft in Frankfurt*, Arbeitspapier 8. Frankfurt: Johan Wolfgang Goethe Universität.
- Grewendorf, G. & Sabel, J. (1999). 'Scrambling in German and Japanese: Adjunction versus multiple specifiers'. *Natural Language and Linguistic Theory* 17 (pp.1-65).
- Grewendorf, G. (2005). 'The discourse configurationality of scrambling'. In: J. Sabel, & M. Saito (eds) *The Free Word Order Phenomenon: Its Syntactic Sources and Diversity*. New York: Mouton De Gruyter.
- Haegeman, L. (1995). *The syntax of negation*. Cambridge: Cambridge University Press
- Haider, H. & Rosengren, I. (1998). 'Scrambling'. *Sprache und Pragmatik* 49 (pp.1-104). Lund: University of Lund.
- Haider, H. (2006). 'Middlefield phenomena (scrambling in Germanic)'. In: M. Everaert & H. van Riemsdijk (eds), *The Blackwell Companion to Syntax Volume III* (pp. 205-274). Oxford: Blackwell Publishing.
- Hauser, M., Chomsky, N. & Fitch, T. (2002). 'The faculty of language: what is it, who has it, and how did it evolve'. *Science* 198 (pp.1569-79).
- Helbig, G. (1992). *Probleme der Valenz- und Kasustheorie*. Tübingen: Niemeyer.
- Hinterhölzl, R. (2006). *Scrambling, Remnant Movement, and Restructuring in West Germanic*. Oxford: Oxford University Press.
- Höhle, T. (1986). 'Der Begriff 'Mittelfeld''. Anmerkungen über die Theorie der topologischen Felder. In: A. Schöne & I. Stephan (eds), *Kontroversen, alte und neue. Akten des VII. Kongresses der Internationalen Vereinigung für germanische Sprach- und Literaturwissenschaft* (pp.329–340). Tübingen: Niemeyer.
- Hornstein, N., Nunes, J. & Grohmann, K. (2005). *Understanding Minimalism*. Cambridge: Cambridge University Press.
- Hoyer, C. (2001). 'On the information structural effects of scrambling in German'. In: M Liakata, B. Jensen & D. Maillat (eds), *Oxford University Papers in Linguistics, Philology & Phonetics* 6 (pp. 91-114).

Huddleston, K. (2010). *Negative Indefinites in Afrikaans*. PhD Dissertation: Utrecht University.

Jeong, Y. (2007). *Applicatives: Structure and Interpretation from a Minimalist Perspective*. Philadelphia: John Benjamins.

Kayne, R. S. (1994). *The antisymmetry of syntax*. Cambridge, MA: MIT Press.

Le Roux, C. (1988). *On the Interface of Morphology and Syntax: Evidence from Verb-particle Combinations in Afrikaans*. PhD. Dissertation, Stellenbosch Papers in Linguistics18: University of Stellenbosch.

Mahajan, A. (1990). *The A/A-bar Distinction and Movement Theory*. PhD Dissertation, Cambridge, MA: MIT

Mahajan, A. (1994). 'Towards a unified theory of scrambling'. In: N. Corver & H. van Riemsdijk (eds), *Studies on Scrambling: Movement and Non-Movement Approaches to Free-Word-Order Phenomena* (pp. 301-330). Berlin: Mouton de Gruyter.

Mahajan, A. (2003). 'Word order and (remnant) VP movement'. In: S. Karimi (ed.), *Word Order and Scrambling..* Oxford: Blackwell Publishers.

Marantz, A. (1993). 'Implications of asymmetries in double object constructions'. In: S. Mchombo (ed), *Theoretical Aspects of Bantu Grammar* (pp.113–151). Stanford: CSLI Publications.

McFadden, T. (2004). *The Position of Morphological Case in the Derivation: A Study on the Syntax-Morphology Interface*. PhD Dissertation: University of Pennsylvania.

Miyagawa, S. (1994). 'Scrambling as an obligatory movement'. In: A. Yasuaki , T. Sakamoto & M. Soga (eds), *Proceedings of the Nanzan Conference on Japanese Language Education and Linguistics* (pp. 81-92). Nagoya: Nanzan University.

Molnárfi, L. (2002). 'Focus and antifocus in modern Afrikaans and West Germanic'. *Linguistics* 40:6 (pp. 1107–1160).

Müller, G. & Sternefeld, W. (1993). 'Improper movement and unambiguous binding'. *Linguistic Inquiry* 24 (pp. 461-507).

Müller, G. (2002). 'Free word order, morphological case, and Sympathy Theory'. In: G. Fanselow & C. Féry (eds), *Resolving Conflicts in Grammars, Linguistische Berichte Sonderheft 11* (pp. 9-48). Hamburg: Helmut Buske Verlag.

Neeleman, A. & Reinhart, T. (1998). 'Scrambling at the PF-interface'. In: M. Butt & W. Geuder (eds), *The Projection of Arguments* (pp. 309-353). Stanford, CA: CSLI Publications,

- Neeleman, A. & Van De Koot, H. (2008). 'Dutch scrambling and the nature of discourse templates'. *The Journal of Comparative Germanic Linguistics* 11:2 (pp.137-189).
- Pesetsky, D. & Torrego, E. (2011). 'Case'. In: C. Boeckx (ed), *The Oxford Handbook of Linguistic Minimalism* (pp. 52-72). New York: Oxford University Press.
- Ponelis, F.A. (1979). *Afrikaanse sintaksis*. Pretoria: Van Schaik.
- Putnam, M. (2007). *Scrambling and the Survive Principle*. Amsterdam: John Benjamins Publishing Company.
- Pylkkänen, L. (2008). 'Introducing Arguments'. *Linguistic Inquiry Monograph* 49. Cambridge: MIT Press
- Ross, J. R. (1967) *Constraints on Variables in Syntax*, PhD Dissertation, Cambridge, MA.: MIT
- Ruys, E.G. (2001). 'Dutch scrambling and the strong-weak distinction'. *Journal of Comparative Germanic Linguistics* 4 (pp. 39-67).
- Stroik, T. (1996). *Minimalism, Scope, and VP Structure*. London: SAGE Publications.
- Tada, H. (1993). *A/A-bar partition in derivation*. PhD Dissertation, Cambridge, MA.: MIT.
- Thráinsson, H. (2001). 'Object shift and scrambling'. In: M. Baltin & C. Collins (eds), *The Handbook of Contemporary Syntactic Theory* (pp. 148-202). Oxford: Blackwell.
- Vikner, S. (1994) 'Scandinavian Object Shift and West Germanic Scrambling'. In: M. Everaert & H. van Riemsdijk (eds), *The Blackwell Companion to Syntax Volume III* (pp. 393-436). Oxford: Blackwell..
- Vikner, S. (1995). *Verb Movement and Expletive Subjects in the Germanic Languages*. Oxford: Oxford University Press.
- Vikner, S. (2006). 'Object Shift'. In: H. van Riemsdijk & M. Everaert (eds), *The Blackwell Companion to Syntax Volume III* (pp. 392-436). Oxford: Blackwell
- Zeller, Jochen (2001a). 'How syntax restricts the lexicon: Particle verbs and internal arguments'. *Linguistische Berichte* 188 (pp. 461-494).
- Zeller, Jochen (2001b). *Particle Verbs and Local Domains*. Amsterdam: Benjamins.
- Zwart, C.J.W. (1993) *Dutch Syntax. A Minimalist Approach*. PhD Dissertation: University of Groningen: Universiteitsdrukkerij Groningen.

Zwart, J. (2005). 'Continental West-Germanic Languages'. In: G. Cinque & R. Kayne (eds), *The Oxford Handbook of Comparative Syntax* (pp. 903-946). Oxford: Oxford University Press.