

**PERFORMANCE OF STUDENTS IN THREE KWAZULU-NATAL COLLEGES OF
EDUCATION ON THE OPEN UNIVERSITY PREPARATORY COURSE 'INTO
SCIENCE'.**

DAVID ANDREW BAILEY

(B.Sc., B.Ed.)

Submitted in partial fulfilment of the requirements for the degree of Master of Education in the
School of Education, University of Natal, Pietermaritzburg.

January 2000.

ACKNOWLEDGEMENTS

I would like to thank my supervisor Mr. David Knox, for all his advice and assistance during this research. The interest that he always displayed was most appreciated.

I would also like to thank the Foundation for Research Development (FRD) for financial support towards this research.

Also, I would like to express my thanks to the contributions made by the college students and college staff involved in this research. Their enthusiasm and the efforts that they made throughout the year were much appreciated.

Finally, to my family and friends, my sincere thanks for your interest and patience expressed throughout the period of this research. Your support was most encouraging.

This entire dissertation, unless specifically indicated to the contrary in the text, is my own work.

All sources used have been indicated in the references listed.

ABSTRACT

The aim of this research was to contribute towards the evaluation of a trialled preparatory science programme called 'Into Science', by investigating to what extent there was an improvement in the participating students' understanding of scientific concepts and their command of science skills.

The sample group involved in the trialling of the 'Into Science' course was students from three interested KwaZulu-Natal Colleges of Education. The research instruments used to determine whether there was an improvement in scientific understanding were largely two sets of pre- and post-tests. The first set was designed around concepts and skills specifically taught by the 'Into Science' course whilst the second set attempted to assess whether there had been any development of the recognised science process skills, using questions which had been designed by the Assessment of Performance Unit (APU) in the United Kingdom. In addition to these pre- and post-tests, a qualitative dimension in the research was also included since it was felt that the impressions of the sample group involved in the trialling of these materials was also important.

The results from this research indicate that the 'Into Science' programme could be successfully used in South Africa, despite some minor reservations discussed in this dissertation. Findings included the following.

- Although almost all the students showed an improvement between the pre- and the post-test on the questions testing 'Into Science' concepts and skills, in the post-test many were still scoring poorly on fairly simple questions. Noticeable improvements were made in areas such as the understanding and application of scientific topics such as area, volume,

density, concepts and terminology associated with basic chemistry, and the plotting and understanding of graphical representations.

- Although it became apparent during the research that certain of the questions used in the ‘APU’ derived pre- and post-tests were problematic in various ways, answers from the students to the questions did complement some of the results obtained from the ‘Into Science’ pre- and post-tests. For example, responses to ‘APU’ derived questions also showed an improvement with respect to the interpretation of graphical representations and the plotting of graphs. In addition however, their answers also provided for some other interesting feedback such as the following.
 - Many of the students experienced problems in answering questions where the data was presented less sequentially or the question was posed in a format which they were not used to.
 - Problems were experienced with the application of conceptual knowledge to experimental situations.
- During interviews conducted at the three colleges, it was found that the majority of the students involved in the trial were most enthusiastic and positive about the ‘Into Science’ materials and the type of teaching and learning format that they had been introduced to during the ‘Into Science’ course. Indeed, the students indicated their interest in pursuing further studies along similar lines, should the opportunity present itself to them at a later date.

If the ‘Into Science’ programme is to be successfully used in South Africa, the recommendation

is that a variety of support structures will also need to be made available in order to ensure the success of the programme. These support structures include the following.

- Weekly tutorial sessions.
- Additional explanation inserts, exercises and assignments in areas of perceived difficulty.
- The establishment of greater confidence with respect to experimental work through the use of frequent laboratory sessions.
- Telephonic and e-mail help lines, fax facilities etc.

TABLE OF CONTENTS

CHAPTER ONE **DEFINING THE RESEARCH QUESTION**

1.1.	Introduction	1
1.2.	Present state of science education in South Africa	4
1.3.	The need to improve the quality of science educators	5
1.3.1.	Role of INSET	5
1.3.2.	Role of distance education	6
1.4.	Open University materials	7
1.4.1.	Necessity for trialling the Open University materials	8
1.4.2.	The 'Into Science' materials	9
1.4.2.1.	Trialling of the 'Into Science' materials	10
1.5.	Aims of this research	12

CHAPTER TWO **LITERATURE REVIEW**

2.1.	Introduction	14
2.2.	School science educators: the South African context	15
2.2.1.	The role of PRESET	15
2.2.2.	Future economic requirements	17
2.2.3.	Proposed curriculum changes	18
2.3.	The concept of distance education	19
2.3.1.	Distance education and teacher education	20
2.3.2.	Distance education and the Open University	23
2.3.3.	A more detailed examination of the 'Into Science' materials	25
2.3.3.1.	Adaptations of the 'Into Science' materials	26
2.3.3.2.	Previous trialling of 'Into Science'	27

2.4.	The science process skills	30
2.4.1.	The Assessment of Performance Unit	32
2.4.2.	Other short term interventions which have promoted the development of science process skills	34

CHAPTER THREE **RESEARCH METHODOLOGY**

3.1.	Introduction	37
3.1.	The research setting	39
3.2.1.	Identification of a suitable sample group	39
3.2.2.	Preparatory visits to the colleges	40
3.2.3.	The final sample group	42
3.2.4.	Conducting the trialled course	43
3.2.4.1.	Factors which resulted in a change in time schedule	45
3.3.	The research instruments	48
3.3.1.	The 'Into Science' pre- and post-test	48
3.3.2.	The 'APU' pre- and post-test	49
3.4.	Precautions taken to ensure test validity	50
3.4.1.	'History'	50
3.4.2.	Instrumentation (instrument decay)	51
3.5.	Qualitative methodologies employed	52
3.6.	Analysis of data	54

CHAPTER FOUR **ANALYSIS OF DATA AND DISCUSSION**

4.1.	Introduction	55
4.2.	The 'Into Science' pre- and post-tests	56
4.2.1.	Mean total scores	56

4.2.2.	Frequency distributions	57
4.2.3.	Scatter diagrams and discussion	57
4.2.4.	'Non scientists' involved in the trial	70
4.2.5.	Mean scores for different topic areas	73
4.3.	The 'APU' pre- and post-tests	77
4.3.1.	Mean total scores and scatter diagram for the combined colleges	77
4.3.2.	Analysis of the individual questions used in the 'APU' pre- and post-tests	81
4.3.2.1.	Rationale for analysis	81
4.3.2.2.	Analysis of the questions	82
4.3.2.3.	General comments as to what was shown by the 'APU' questions	101
4.4.	Qualitative data	103

CHAPTER FIVE SUMMARY AND CONCLUSIONS

5.1.	Introduction	106
5.2.	Summary of the major findings that emerged	106
5.3.	Some concluding remarks	112

<u>REFERENCES</u>	116
--------------------------	-----

LIST OF TABLES

Table 1:	Robertshaw's findings from an evaluation of the 'Into Science' and 'S102' courses	27
Table 2:	APU categories of science performance	33
Table 3:	Envisaged duration of the trialled 'Into Science' course	44

Table 4:	Mean pre- and post-test scores (percentage) on the ‘Into Science’ tests	56
Table 5:	Matched pre- and post-test scores for ‘non science’ students who completed the ‘Into Science’ course	71
Table 6:	Mean pre- and post-test scores by question topic	73
Table 7:	Mean ‘APU’ pre- and post-test scores for students completing the ‘Into Science’ course	77

LIST OF FIGURES

Figure 1:	Frequency distribution of scores obtained on the ‘Into Science’ pre- and post-test for college A	58
Figure 2:	Frequency distribution of scores obtained on the ‘Into Science’ pre- and post-test for college B	59
Figure 3:	Frequency distribution of scores obtained on the ‘Into Science’ pre- and post-test for college C	60
Figure 4:	Frequency distribution of scores obtained on the ‘Into Science’ pre- and post-test for the combined colleges	61
Figure 5:	Scatter diagram of the ‘Into Science’ pre- and post-test scores for college A	62
Figure 6:	Scatter diagram of the ‘Into Science’ pre- and post-test scores for college B	63
Figure 7:	Scatter diagram of the ‘Into Science’ pre- and post-test scores for college C	64
Figure 8:	Scatter diagram of the ‘Into Science’ pre- and post-test scores for the combined colleges	65
Figure 9:	Scatter diagram of the ‘APU’ pre- and post-test scores for the combined colleges	79

APPENDICES

	122
Appendix 1: Information given to the students on the 'Into Science' course	123
Appendix 2: Registration form for the 'Into Science' course	124
Appendix 3: Reduced copy of the advertising poster	125
Appendix 4: The 'Into Science' and 'APU' pre- and post-tests.	126

CHAPTER ONE

DEFINING THE RESEARCH QUESTION

1.1. INTRODUCTION

In the Zuckerman Lecture: “Science and Technology in South Africa: Future Directions”, in London on 31 October 1995, Ben Ngubane, then Minister of Arts, Culture, Science and Technology, made the following points with regards to the imperative for reconstruction and development.

- Acceptance of the need for a growth rate of between 5% and 8% in the South African economy, in order to meet the needs for wealth and job creation in our country.
- Acceptance of the fact that South Africa can only meet these demands provided a high level of adequate numbers of technological manpower can become available.
- Acceptance of the fact that in the new world order, competitiveness is less determined by natural resources, low-cost labour, and other classical advantages of the past, than by abilities to generate and access rapidly new knowledge and technical insights, and to convert them into quality products, processes and services.
- Acceptance of the fact that wealth distribution can be achieved most effectively by skills distribution among all parts of the population, and especially among those who were prevented from making a contribution in this regard in the past (Ngubane, 1996).

Whilst all educators have a ‘crucial role to play’ in the alleviation of the educational crisis that was inherited by the new democratic government, there is almost universal agreement that if South Africa is to become internationally competitive and meet the needs for reconstruction and

development as outlined by Ben Ngubane, then access to science education has to be broadened. As Khan and Rollnick (1993) point out, "...there is agreement that the technological future of the country depends *inter alia* on developing all its citizens into a scientifically literate community" (pp. 261-262).

If one examines the educational policy alternatives that began to emerge from the early 1990's as South Africa moved towards increasing democratisation, it is apparent that the subject area of science was especially focussed upon; a focus which accelerated with the creation of the Reconstruction and Development Programme (RDP) whose goals of growth and development, "acknowledged dependence upon the development of human resources, especially in the fields of science and technology" (Khan, 1995:445). Possibly the greatest contributions which have been made in science education since restructuring began are the following.

- The recommendations of the National Educational Policy Investigation (NEPI) that approaches towards the teaching of science, as well as the necessity of promoting the professional development of science teachers, need to be addressed (Khan, 1995).
- The recommendations for the area of science, mathematics and technology education and training (STM) of the ANC's Policy Framework for Education and Training, that in order to provide quality science and mathematics education, there needs to be reconstruction of the entire science curriculum and a concentration upon the development of in-service educational opportunities for teachers (Khan, 1995).
- The work of the National Curriculum Development Committee (NCDC) which was responsible for the development of the 'Lifelong Learning Framework', a policy document which makes a firm commitment towards outcomes-based learning and which was responsible for informing the 'Curriculum 2005' proposals. The Natural Sciences

Learning Area report of these proposals is firmly committed towards the idea of a scientifically literate community, which can be seen in its rationale which states that the Natural Sciences should “contribute to the development of responsible, sensitive and scientifically literate citizens who can critically debate scientific issues and participate in an informed way in democratic decision making processes” (policy document of the Natural Sciences: National Department of Education, 1997). In recognition of this pivotal role that will need to be played by science teachers in ensuring that the curriculum proposals are relatively successfully implemented, the Natural Sciences Learning Area committee was extensively informing, consulting and workshopping these proposals throughout 1997.

What has been evident in these emerging policies, is that all the proposals have been characterised by the recognition of the fundamental role that will need to be played by teachers, if science education is to be even partially successful as South African education moves into the next millennium. The new curriculum proposals depend upon committed, innovative and ‘professional’ teachers who possess a high quality scientific understanding and who have confidence in their ability to transmit this understanding to their charges. At present however, these characteristics of a competent scientific educator workforce are not even remotely apparent. Many commentators acknowledge that science education in South Africa is in a state of extreme crisis: as Khan and Rollnick (1993) state, “...in total chaos, approximating the aftermath of a war” (p. 266).

1.2. PRESENT STATE OF SCIENCE EDUCATION IN SOUTH AFRICA

Research indicates that many secondary schools lack qualified science teachers. Some of this research shows.

- Ziervogel found that in some circuits in 1994 near Empangeni in KwaZulu-Natal, only 40% of the teachers teaching biology were qualified to do so (Cited in University of Natal, Pietermaritzburg, 1996: Discussion Document).
- In the Pietermaritzburg region of KwaZulu-Natal, one of the subject advisors for Biology, Mrs G. Khumalo, found that only 39% of a sample of teachers teaching Biology in Pietermaritzburg secondary schools, possessed a tertiary Biology qualification (Sokhela, 1998).
- In Physical Science, only 15% of black matriculants wrote the Physical Science papers in 1992, and only 7% passed (Gray, 1995). Although many factors contribute to this appalling pass rate (eg: inadequate facilities for science teaching, localised political unrest etc) there can certainly be no doubt that the chronic lack of understanding and skills possessed by many science teachers is a major contributing factor. Indeed in a survey conducted by Moller (1987) of 3500 black matriculation students, teachers were identified by the students as the most important factor which hindered their development and progress.

This lack in knowledge and qualifications has an important 'knock on' effect. Not only does it result in fewer school pupils being willing to take science subjects but it also restricts the pool of potential candidates willing to embark upon tertiary education programmes which are of a scientific nature. Sadly, the end result is that fewer and fewer science teachers are being

generated by tertiary institutions, at a time when a drastic increase in the production of science teachers is required.

Certainly for the next few decades the situation has the potential to remain very bleak. Whilst not ignoring the vital role of pre-service training (PRESET), the immediate focus of attention has to be on the underqualified and unskilled science teachers who are already in the profession. If the 'cycle of mediocrity' is to be broken quickly, the rapid improvement in the abilities of these teachers is imperative. But how can this be achieved? The answer it is felt by many commentators, is to be found within the key area of in-service training (INSET).

1.3. THE NEED TO IMPROVE THE QUALITY OF SCIENCE EDUCATORS

1.3.1. ROLE OF INSET

It cannot be denied that the backbone for improvement lies with INSET. As Brian Gray (1995) points out, "INSET is grossly under-prioritised and the educational authorities need to embark on a major reassessment of their attitude towards it" (p. 47). Lately, it would appear to me that perhaps this 'reassessment' has been occurring. My impression, which has been reinforced through casual contact with other science teachers, is that a degree of success has been attained during the last few years with provincial education department INSET courses, especially in the biological sciences. The amount of work-shopping has been impressive and certainly as the implementation date for the new 'Curriculum 2005' proposals approached, a very concerted effort was being made to consult and inform all stake-holders by the educational authorities.

Unfortunately, there are problems associated with many of these INSET courses. In a workshop conducted by Michael Kahn with a range of organisations, policy makers and funding agencies associated with science education, the following problems with regards to INSET courses were raised (Khan, 1996).

- “The returns from INSET over the years were somewhat intangible...INSET is regarded almost as a first aid measure, like Saturday schools, where an artificial environment is created....they go back to their schools and it doesn’t make any difference...there is a reality gap” (p. 515).
- “...teachers are reaching saturation point of attending courses for courses’ sake” (p. 515).
- Possibly one of the most severe problems that was raised by this workshop concerning INSET courses, both in the relevancy of the courses and the actual physical attendance of these courses, were the difficulties experienced by teachers from rural areas. For rural teachers, the attendance of such courses often involves travelling considerable distances, which can become extremely counter-productive in terms of valuable classroom time being lost.

1.3.2. ROLE OF DISTANCE EDUCATION

The obvious solution to these difficulties experienced by rural teachers, lies in the utilisation of high quality distance education materials. This necessity for distance learning in order to improve the competency and confidence of science teachers, especially in KwaZulu-Natal which possesses a high number of rural schools, began to be explored by the University of Natal, Pietermaritzburg, in 1994. Co-ordinated by Mr David Knox, a senior lecturer in education on the campus, the feasibility of providing a new Further Diploma in Education (FDE) programme,

aimed at improving the understanding of secondary school science and how to teach it, began to be examined.

1.4. OPEN UNIVERSITY MATERIALS

The production of high quality distance education materials is an extremely time consuming and expensive undertaking. Such an undertaking also relies upon the availability of suitably skilled science educators, of which there is a limited supply in the Pietermaritzburg area, that would be able to involve themselves to the extent that would be required of them. One answer therefore would be to use existing high quality distance education materials which have a proven 'track record' in terms of science education and which would enable the learning programme to be implemented as rapidly as possible. The Education Department of the University identified some such materials, used by the Open University (OU) in the United Kingdom. These materials have been extensively developed over a number of years, and place a great emphasis on providing substantial student support in the form of tutorials, regular sessions and frequent assignments with rapid feedback.

At present there are a number of FDE courses which are offered by various institutions in KwaZulu-Natal. Questions have therefore been raised with regards to the feasibility of offering another FDE course aimed at secondary school science teachers, especially when there is a limited potential market for such a course. An examination of these other FDE and related courses however, indicates that many of these courses are aimed more at the content and associated methodologies required for the teaching of specific sections of the present school syllabi, or are not aimed at the university level. The OU materials however have the following

strengths.

- The materials require constant thinking and reflection. They are orientated more towards an ‘in depth’ understanding of science, attempting to not only equip learners with the necessary knowledge, but also attempting to develop the higher order thinking skills as well. This ‘in-depth’ understanding of science will certainly help to ‘empower’ our teachers, especially as they begin to face the demands required from Outcomes Based Education (OBE) in the years to come.
- The OU materials also have the advantage in that they are an ‘open access’ course which demands no previous knowledge of science. The materials will therefore allow access to not only incumbent science teachers, but also those teachers who are not science trained but through various circumstances might be involved in the teaching of one or more of the sciences, or may wish to move into the domain of science teaching. This access is seen as very important if the whole ‘cycle of mediocrity’ previously discussed is to be addressed. Clearly a very rapid increase in the number and quality of science teachers needs to be attained. If this is not done, our potential to become a productive nation may never become a reality.

1.4.1. NECESSITY OF TRIALLING THE OPEN UNIVERSITY MATERIALS

Having had the justification for such a course successfully motivated by the Education Department to the Academic Affairs Board, the University then applied to the Committee on Teacher Education Policy (COTEP) for approval, which was subsequently granted. However, in further formal and informal discussions held with interested parties, some doubts were raised concerning the proposed FDE course and the use of the OU materials. Some of these included:

1. Will the students, considering that most of them would be in full time employment, be able to proceed through the course at the speed envisaged by the OU?
2. The materials rely upon a considerable amount of reading; would the students be able to cope with this amount?
3. Were the knowledge and skills that the course hoped to develop, possibly not too advanced for the type of students that would undertake the course in this country?
4. Was the material too British orientated in context? Would this orientation not hamper the understanding of South African students?
5. Will an OU based course, with content not particularly linked to teaching, not provide an avenue to actually take science teachers out of the classroom?
6. Will the students be prepared to pay the fees for this course, particularly if other courses are cheaper and less demanding?

Partly because of these doubts, it was decided not to implement the FDE in January 1997 as was originally envisaged. Instead, the decision was made to trial what was intended to be the first part of the course; preparatory materials called 'Into Science'.

1.4.2. THE 'INTO SCIENCE' MATERIALS

'Into Science' is a skills-based introduction to the learning of science. It consists of 12 self-study modules supplemented by an assignment booklet and workbook. The modules are organised in such a way that the skills and concepts that are covered become progressively more difficult. Each of the modules also requires a progressively longer study time, in order to provide learners with the important skills associated with distance learning, of managing increasing quantities

of written material, accelerating the pace of study and organising and managing their study time.

(In Chapter Two, the ‘Into Science’ course will be discussed in far more detail.)

The ‘Into Science’ course team saw their aims as being to produce material that:

- had a straightforward design so that it could be adapted for multiple use;
- would develop scientific, mathematical and study skills;
- would introduce all major scientific disciplines;
- was relevant to the learners’ experience and began from their understanding and knowledge of science (Metcalf and Halstead, 1989).

Of particular relevance for the proposed trialling of the ‘Into Science’ course are the following points made by Halstead and Metcalfe (1989).

“Into Science modules have been written to be easily understood by people from all backgrounds, regardless of previous study experience or existing scientific skills or knowledge.

The material is ideal for adults taking up study for the first time, wanting a refresher, considering science as a change of career direction, or preparing themselves for studying at a degree or diploma level in science subjects” (p. 261).

1.4.2.1. TRIALLING OF THE ‘INTO SCIENCE’ MATERIALS

Clearly therefore, the trialling of ‘Into Science’ would provide valuable indications in terms of whether this type of course and format of learning would be likely to succeed in the South African context. Particularly useful would be to check the statements of the UK ‘Into Science’ team as to whether the degree of pre-requisites is indeed very low, and whether this type of

course is accessible to students who possess a variety of backgrounds in terms of their initial science training that they had received.

At this stage, it must be mentioned that the 'Into Science' course has been previously trialled in South Africa. The South African Institute for Distance Education (SAIDE) set up a research project in 1994 to investigate the use of imported distance education courses for its proposed Access Programme. Mike Robertshaw, an external consultant from the Open Learning Institute of Hong Kong, was appointed to evaluate the trial, which was conducted at the University of Orange Free State. The trial however deviated from the normal 'Into Science' course in the following ways.

- Only the first six modules of the course were studied, which precluded important aspects of the programme such as the assessment tasks.
- The course was accelerated due to time constraints.
- The students were not involved in their normal full - time daily activities as the course was conducted during their summer holidays.

The SAIDE trial therefore, whilst providing insights and recommendations (which will be examined in more detail in Chapter Two), is felt not to be a true reflection of normal study conditions. The trial reported here it is hoped, will provide a more detailed and relevant analysis.

The sample group involved in the trialling of the 'Into Science' course were students from three interested KwaZulu-Natal Colleges of Education. The group consisted of 68 students of mixed courses from one college (college A), 36 year 3 Primary students from a second college (college

B) and 23 first year students from a third college (college C). The students from college A and B were participating in the trialled course as a voluntary extra activity whilst at college C, the trialled course was incorporated into the college curriculum.

A rigorous evaluation of a course such as 'Into Science' is fairly large in scope. The evaluation was therefore conducted jointly with Kitty Sokhela, a fellow full time M.Ed. student, although the aspects examined and the evaluation techniques employed did differ considerably. Kitty Sokhela concentrated more upon the perceptions of the students who underwent the trial, in terms of the suitability of the 'Into Science' course materials, whilst my research was orientated more towards what the students actually learnt from the course. Both of these aspects are considered to be very important in an evaluation of a course such as 'Into Science', in terms of the future implementation of the proposed FDE.

1.5. AIMS OF THIS RESEARCH

The aim of this research therefore, was to contribute in the evaluation of a trialled preparatory science programme called 'Into Science', by investigating to what extent there has been an improvement in the participating students' understanding of scientific concepts and their command of science skills.

The research instruments used to determine whether there had been any improvement in understanding, were largely two sets of pre-and post-tests. The first set was based on the concepts dealt with by the 'Into Science' course, whilst the second set was designed around questions mainly used by the Assessment of Performance Unit (APU) in the United Kingdom,

questions mainly used by the Assessment of Performance Unit (APU) in the United Kingdom, and was concerned more with whether there had been any development in the recognised science process skills. Following the administration and marking of these tests, a statistical analysis was then performed on the results and conclusions derived.

Although the research is basically quantitatively orientated, a qualitative dimension has been included, in that the impressions of both the students and the college staff as to whether they feel that any improvement has occurred, have also been explored. This took place through informal discussions, participant observation in tutorials and semi-structured interviews conducted with the students.

CHAPTER TWO

LITERATURE REVIEW

2.1. INTRODUCTION

The review of literature in this chapter will focus upon the following aspects.

1. Secondary school science in South Africa will be placed in context, through a brief examination of the reasons as to why school science education in this country is currently experiencing considerable difficulties: difficulties which have to be overcome if South Africa is to meet the economic challenges of the future.
2. The role that distance education could play in supporting and improving the skills of underqualified or poorly qualified science teachers. Examples of success in distance education in this respect, and in particular the success of the OU materials, will be mentioned.
3. The 'Into Science' materials will be examined in far more detail. Examples of how these preparatory materials have been adapted to different contexts, as well as the recommendations arising through a trial conducted by SAIDE, will be focused upon.
4. Since one of the pre- and post-tests is directly concerned with science process skills, these skills will be addressed in more detail. The work of the APU, as well as examples of short term interventions which have directly led to an improvement in the process skills of the participants, will also be discussed.

2.2. SCHOOL SCIENCE EDUCATORS: THE SOUTH AFRICAN CONTEXT

Although many countries in the world face a serious shortage of science and mathematics teachers, the situation in South Africa is especially desperate and as pointed out by Khan, Volmink, and Kibi (1995), “is unique, arising through deliberate government policy, traceable back to the days of ‘grand apartheid’ ” (p. 421). By unashamedly using education in order to legitimise its ideological claims, the apartheid government not only denied quality education to the majority of its nation’s citizens, but also “stifled the development of critical, creative, innovative teachers who are capable of taking initiative” (Gray, 1995:48). The consequence of this was particularly devastating in the field of science and mathematics education, which is evident by the large number of underqualified teachers which presently abound in the system: teachers who are not only inadequately versed with respect to basic scientific content, but who also “lack the confidence and necessary organisational and teaching skills for practically-based science lessons” (Gray, 1995:48).

2.2.1. THE ROLE OF PRESET

One of the important consequences of such inadequately prepared teachers, which has been frequently noted by many commentators, concerns the establishment of a highly developed ‘cycle of mediocrity’, responsible for perpetuating and reproducing a poorly trained and ill-equipped teaching force. New students entering into tertiary institutions, will often base their future perceived role on the experiences that they encountered at their schools, unless the training institutions that they attend, manages to negate the powerful effects of these school based experiences. As Gray (1995) points out, “teacher education programmes present an

opportunity to break into the vicious cycle in which teachers are trapped with respect to teaching models and professionalism” (p. 48).

Unfortunately however, PRESET institutions, in particular the colleges of education, have historically been “bureaucratic institutions not known for innovative work and thinking, and possess a large amount of inertia when it comes to change” (Salmon and Woods, 1991:48). Much of this inertia, as Cross and Schoole (1997) in a paper aimed at examining the findings of the National Teacher Education Audit found, are due to the almost insurmountable problems that these institutions face, in that there is “duplication of programmes across institutions, neglect of training of teachers in specialised education, questionable programmes, methods and practices which still prevail in most of these institutions, poor training facilities that also militate against quality and too old-fashioned philosophies which underpin prevailing practices” (pp. 48-49).

Cross and Schoole (1997) argue for the “need for a systematic reconstruction of the teacher education sector based on a national policy framework” (p. 51). They believe that such reconstruction needs to take place “within a framework of a well-synchronised and co-ordinated inter-institutional articulation and collaboration” (p. 55). It would appear that this reconstruction will be an exceedingly complex process. It is far beyond the scope of this discussion to examine the process and the suggestions that have been put forward in any great detail, except to comment upon the time framework envisaged. Cross and Schoole believe that the complexity of the process infers that the reconstruction will be a lengthy process, due to the range of re-organisations and re-definitions required.

Of far greater relevance to this research however, are the measures that are needed to address the chronic problem of the underqualified teachers that already exist in the system. Many of these teachers are only in their early and mid careers and will remain in the field of education for decades to come. An urgent upgrading of their skills and knowledge requires attention now. To delay, will ensure that South Africa remains at the “bottom in terms of development of its human resources among the newly industrialising countries” (Khan, 1995:446).

2.2.2. FUTURE ECONOMIC REQUIREMENTS

In an article entitled: “The writing on the wall of South African science: a scientometric assessment”, Anastassios Pouris (1996) asserts that: “South African science is losing ground in a world in which science appears to be growing ever more competitive”(p. 270). He maintains that South Africa over the last two decades, from a position of relative strength in the sciences, has begun to steadily lose ground “as the world moves into an era where the winning economies and industries are becoming increasingly dependent on science” (1996:270).

As the new millennium approaches, innovations and technological transformations are taking place with breath-taking rapidity. Clearly the parameters which used to determine whether a nation was economically successful or not have changed considerably, particularly during the 1990's amidst “one of the most significant technological revolutions in human history” (Sellschop, 1995:551). Past yard-sticks that were used by nations as indicators of economic stability and influence (many of which South Africa possessed) no longer apply. As Sellschop states: “Success in the new system is based less on the location of natural resources, cheap and abundant labour, or even capital stock, and more on the capacity to create new knowledge and

apply it rapidly through information processing and telecommunications to a wide range of human activities in ever-broadening space and time” (p. 551).

2.2.3. PROPOSED CURRICULUM CHANGES

Apart from the need for upgrading skills and knowledge due to economic necessities, on a more practical level, the introduction of Outcomes-Based Education (OBE) in this country means that teachers need to be empowered in terms of equipping their learners with the necessary knowledge and skills, in order to be able to demonstrate the outcomes required by OBE. As was mentioned in Chapter One, an ‘in-depth’ understanding of science, particularly at the senior school level, is very important if this is to be attained.

This lack of ‘in-depth’ understanding, became apparent during a B.Ed. course conducted in June/July 1997 at the University of Natal, Pietermaritzburg, by Mr David Knox, senior lecturer in the Education Department. The course was a one week full-time course, which was designed to help teachers implement OBE. An analysis by David Knox of the assignments done by the students, revealed many areas of common weaknesses. One of them was: “Descriptions of assessments were often very vague. Where they were specific, they often tended to reveal a preoccupation with learning names and words, rather than anything resembling higher order thinking skills” (Discussion Document on B.Ed. Course, 1997:1). Knox states that he has “a very strong suspicion that many or most of the teachers hold a ‘product-centred’ view of knowledge - education is learning names and facts and how to learn simple routines such as multiplying - rather than a ‘process-centred’ view, in which education is learning how to solve problems and use higher-order thinking skills” (p. 1-2). He believes that in order to change from

apply it rapidly through information processing and telecommunications to a wide range of human activities in ever-broadening space and time” (p. 551).

2.2.3. PROPOSED CURRICULUM CHANGES

Apart from the need for upgrading skills and knowledge due to economic necessities, on a more practical level, the introduction of Outcomes-Based Education (OBE) in this country means that teachers need to be empowered in terms of equipping their learners with the necessary knowledge and skills, in order to be able to demonstrate the outcomes required by OBE. As was mentioned in Chapter One, an ‘in-depth’ understanding of science, particularly at the senior school level, is very important if this is to be attained.

This lack of ‘in-depth’ understanding, became apparent during a B.Ed. course conducted in June/July 1997 at the University of Natal, Pietermaritzburg, by Mr David Knox, senior lecturer in the Education Department. The course was a one week full-time course, which was designed to help teachers implement OBE. An analysis by David Knox of the assignments done by the students, revealed many areas of common weaknesses. One of them was: “Descriptions of assessments were often very vague. Where they were specific, they often tended to reveal a preoccupation with learning names and words, rather than anything resembling higher order thinking skills” (Discussion Document on B.Ed. Course, 1997:1). Knox states that he has “a very strong suspicion that many or most of the teachers hold a ‘product-centred’ view of knowledge - education is learning names and facts and how to learn simple routines such as multiplying - rather than a ‘process-centred’ view, in which education is learning how to solve problems and use higher-order thinking skills” (p. 1-2). He believes that in order to change from

this 'product-centred' to a 'process-centred' view of knowledge, it is imperative that: "A greater understanding of the subject matter - 'concepts and skills in-depth' - by the teacher", has to be attained. He continues by stating that "this is time-consuming and expensive to achieve, and I think that most INSET programmes world-wide, tend to duck this fundamental issue" (p.2).

It is clear therefore that future economic requirements, as well as the proposed education curriculum changes, impose a need to rapidly improve upon the quality of science education which is presently taught in this country to the majority of learners. It is in this respect, that many commentators are beginning to increasingly look towards distance education as a possible means of facilitating this rapid improvement.

2.3. THE CONCEPT OF DISTANCE EDUCATION

For many years, distance education programmes have had a major role to play in many countries, in supplying newly qualified teachers and in supporting and improving the skills of underqualified or poorly qualified teachers already in the field. As Perraton (1993) states, "they have been used in rich and poor countries, for experienced and unexperienced teachers, at primary, secondary and tertiary levels, to provide a general education and to improve pedagogical skills, to overcome what was seen as a short term crisis and to serve as part of a regular system of continuing education" (p. 8).

To pinpoint a definition for distance education is not particularly easy. As Johnston (1997) points out: "Much has been written to define distance learning and to distinguish it from, or associate it with, similar titles such as 'open', 'flexible', or 'independent learning' " (p. 107).

This has led to various classification systems being postulated, none of which satisfactorily “define an increasingly diverse variety of learning systems” (ibid., p. 107). Yusef Waghid (1996) however, argues that distance education “like any other concept, has a distinctive meaning grounded in a historical context” (p. 205), and draws on Steward’s (1981) description of distance education which is: “It denotes the forms of study not led by teachers in the classroom but supported by tutors and an organisation at a distance from the student” (p. 1). According to this definition therefore, distance between the teacher and the student is the distinguishing characteristic which separates distance education from other forms of education. Reading through other literature sources [Keegan (1990), Torres (1996), Kaye and Rumble (1991)], it does appear that most definitions reflect this distinguishing feature.

2.3.1. DISTANCE EDUCATION AND TEACHER EDUCATION

Quoting from a World Bank review, Torres (1996) examines the potential role that distance education can play in promoting teacher qualifications: “The specific comparative advantages of distance modalities are the possibility of learning in situ (without taking teachers away from their classrooms) and its potential for addressing hard-to-reach populations” (p. 457). These advantages have already been discussed in Chapter One when motivating the need for a course such as ‘Into Science’.

In a paper entitled “Can distance education engender effective teacher education in South Africa”?, Yusef Waghid (1996) not only elaborates on the above two points, but also extends the discussion into a number of other crucial areas that are specific to the South African context. Some of the points that he makes are the following.

- “Facilitating the development of competent, flexible and resilient teachers, capable of revitalising schools and responding to the changing demands of educational practice” (p. 208). As previously mentioned, this is now particularly pertinent with respect to the proposed OBE curricula.
- He also establishes a linkage between distance education and the democratic rights of teachers by arguing that distance education can provide the necessary “conditions for the free and full development of their essential human capacities” (p. 206).

With regard to teachers therefore, Waghid believes that a democratic form of distance education will allow for effective teacher development in the following ways.

1. “Fostering wider consultation and interaction between participants in the distance education programme for teacher development. This process may involve networking between all stakeholders (which may include academics, trained tutors, mentors, material writers, learners/teachers, peer or support groups and educational institutions) in the distance education design” (p. 209).
2. “Facilitating the acquisition of skills on the part of learners/teachers (through innovative distance education materials) which may cause them to choose, develop and utilise learning material akin to their contexts, adopt the appropriate techniques of teaching when planning learning situations; draw up a systematic teaching - learning process in keeping with the versatile needs of the pupils; plan and evaluate methods and tests to assess the students’ progress in learning; maintain successful classroom management by organising a conducive environment which would motivate pupils to learn; and, maintain good inter-personal relationships with the broader school community” (p. 209).
3. “Preparing their pupils to become self-assured, skilled and educated individuals who are

ready to play contributory roles socially, economically and politically” (p. 209).

In his article, Waghid also specifically refers to science teachers, stating that distance education can have a significant role in: “Redressing the chronic inadequacy of mathematics and science teachers in schools, which as a consequence results in a dearth of students with those subjects who may (if in possession of science and mathematics) qualify for access to higher education” (p. 208).

Cilliers, Kirschner, and Basson (1997) are also positive in this regard, in their examination of distance education and physics, stating that: “Higher distance education can play an increasingly important role in South Africa’s educational system.....serve primary and secondary education by increasing the level and competence of primary and secondary education teachers through in-service teacher training” (p. 120).

There is little doubt therefore, that there is certainly room for distance education in terms of in-service training and the professional up-grading of teachers. Many countries, particularly developing countries, have realised this potential and there are many successful examples of teacher distance education programmes. Some of these are listed below.

- The Zimbabwe Integrated Teacher Education Course.
- Logos 2 in Brazil.
- Teacher upgrading in Sri Lanka and Indonesia.
- The Primary Teachers’ Orientation Course; Allama Iqbal Open University, in Pakistan.
- Tanzania’s distance teaching programme.

- The external degree programme at the University of Nairobi.

(Examples quoted from Perraton, 1993:12-15)

2.3.2. DISTANCE EDUCATION AND THE OPEN UNIVERSITY

One of the largest and most complex of the distance teaching organisations is the United Kingdom Open University. Since the presentation of its first courses in 1971, the OU has grown rapidly, and today can boast of an extremely impressive range of courses, which rely upon high quality learning materials and which are delivered very effectively.

Part of the range of courses offered, are exclusively teacher education courses. Prescott and Robinson (from Perraton, 1993) quote a number of features and statistics concerning the OU teacher education materials, which ably demonstrate how successful the OU approach has been.

- “In a study of the influence of the OU on teacher education in Scotland, Marker (1991) suggests that its contribution to the post-experience education of Scottish teachers in the last 20 years has been very considerable” (p. 279).
- “There are also large sales of individual course units (3,500 in all subjects) to 70 UK higher education institutions and a number of adjacent bookshops” (p. 300).
- “From its introduction (between 1973 and 1978) it had provided the full-time equivalent of some 600 teacher-study years, the equivalent of just over 13% of the total annual provision by all other means. Similarly, the taught MA in Education with around 2,200 students in 1991, accounted for approximately 40% of all part time MA’s in Education registrations at universities in England and Wales” (p. 293).

And more generally:

- “The quality of OU materials is generally high and tends to be widely recognised as such. This quality is probably due in large part to the level of resources (far exceeding that to be found in other institutions) which goes into the production of the courses, and to the experiences the OU has accumulated in designing and producing them. Significant levels of expertise (academic, professional, editorial, design and media) can be brought to bear, together with the involvement of real teachers and real schools in the construction of the materials. Course materials are generally well-researched and up-to-date, and include examples of recent practice and innovation” (p. 300-301).
- “The OU’s involvement in INSET has been broadly based and has become a visible and accepted part of INSET provision. Some of its courses have recruited thousands of students over the course’s lifetime, and have demonstrated the economies of scale important for distance-teaching institutions” (p. 313).

An example of one of these high quality successful OU courses, is their level one science course called ‘S102’ on which the proposed FDE envisages basing its first year. The main features of the course are as follows.

1. The preparatory course ‘Into Science’, which is non - compulsory.
2. Course units which include the ‘Home Experiment Kit’. This kit will allow the students to perform an average of one experiment per week, at home.
3. Weekly TV programmes (about 32 altogether).
4. Regular tutorials.
5. Assignments - The assignments consist of computer marked multiple choice assignments and more ‘open-ended’ tutor marked assignments. The assignments are designed to allow for rapid feedback on performance.

6. A one week 'summer school', where the students perform practical activities and observe demonstrations.

2.3.3. A MORE DETAILED EXAMINATION OF THE 'INTO SCIENCE' MATERIALS

The 'Into Science' materials mentioned in Chapter One, will now be examined in more detail. The examination will focus on the materials themselves, how these materials have been adapted by other institutions and the findings and recommendations of a previous trial of 'Into Science' conducted in South Africa.

As mentioned in Chapter One, 'Into Science' is a skills based introduction to the learning of science. Each one of the 12 modules focuses on a particular topic, which was chosen for its everyday relevance, in an attempt to establish an enthusiasm with respect to science. The skills and concepts taught by the modules, become progressively more difficult as the student proceeds through the course. These skills and concepts are not found exclusively in any one module however, since throughout the course, what is learnt is constantly revisited, thus allowing for continuous reinforcement.

Apart from the modules, the course pack also consists of a workbook and an assignment booklet. The workbook is directly based around the 12 modules, and consists of numerous exercises, which provide the students with ample opportunity for an extensive revision of these skills and concepts learnt, as well as extending the student with more difficult examples. The assignment booklet consists of two multiple choice assignments and two tutor marked assignments. These assignments form the basis of the assessment for the course.

Metcalf and Halstead (1989) believe that “ ‘Into Science’ is designed as a coherent course with a logical progression” (p. 262). They make the following points, which are important in terms of our research rationale: “..... there is flexibility for individual modules to be used in courses with different emphases. The modules can be adapted for use as access material to any subject area which includes elements of physical or life sciences. So, although the modules are interlinked and cross-referenced, a number of alternative routes through the material are possible in order to meet the needs of different groups of students” (p. 262).

2.3.3.1. ADAPTATIONS OF THE ‘INTO SCIENCE’ MATERIALS

The ‘Into Science’ materials have been adapted by a number of institutions. Some of these adaptations are illustrated by the following examples.

- The Leicester Open College Network, on behalf of the National Open College Network in the UK, recognised the ‘Into Science’ programme for accreditation. Centres are using the ‘Into Science’ programme “in a diversity of ways: as part of an Access programme and as part of a return to learn course” (Hoadley-Maidment, 1992:95).
- A programme based on ‘Into Science’, “has also been formally recognised as satisfying an equivalence to GCSE in General Science at grade C, for entry to Initial Teacher Training” (Metcalf and Halstead, 1994:262).
- Of particular relevance to the University’s proposed FDE, were the following findings of Metcalf and Servant (1996) illustrated in a paper entitled: “Alternative Uses of an Open University Pack.” In their investigation, Metcalf and Servant found that: “One college used the pack as the basis for a pre-foundation science course for adults. It served a dual purpose in that it helped the tutors assess the mature learners and it

provided an opportunity for the students to measure their mathematical abilities before going on to study a foundation science course” (p. 175).

The above examples indicate the extent to which the OU science materials are recognised as high quality, and the extent to which the adaptability of the materials can easily be achieved through flexibility of approach.

2.3.3.2. PREVIOUS TRIALLING OF ‘INTO SCIENCE’

As mentioned in Chapter One, the ‘Into Science’ course has been previously trialled in South Africa. SAIDE appointed an external consultant, Mike Robertshaw, to assist in the evaluation of five different courses, in order to determine whether these courses were suitable for SAIDE’s planned Access Programme. ‘Into Science’ was one of the courses; one of the other courses of direct relevance to this research being the ‘S102: A Science Foundation Course’. The following are Robertshaw’s impressions of the materials and his findings (Robertshaw, 1995:12-20).

Table 1: Robertshaw’s findings from an evaluation of the ‘Into Science’ and ‘S102’ courses

INTO SCIENCE	S102
<p>A. IMPRESSION OF COURSE MATERIALS</p> <p>1. A well planned and organised introduction to science at the OU’s foundation level.</p>	<p>1. A very well structured course which provides excellent support for the students.</p>

<p>2. A useful course for those needing a more structured preparation for the S102 course.</p> <p>3. Prior to the trial, concern was expressed by some commentators with regards to the cultural and social content. Eg. Module 3 discusses geology, which is exclusively UK in orientation. It was found however that the students were not concerned. They felt that they could apply the UK principles to the South African context. Robertshaw however, feels that a local tutor would have to be appointed to explain the British references. In this regard, he feels that the introduction and guide will need to be re-written.</p>	<p>2. The course has an ambitious foundation course, which introduces students to general scientific concepts, but in great detail.</p> <p>3. Reservations were expressed concerning the size and coverage of the course. An estimated 600 hours of study would require considerable dedication.</p> <p>The course makes use of home experiment kits which Robertshaw feels, for a number of reasons, would not be an option in South Africa. 'Summer School' laboratory work therefore, he feels would have to be arranged.</p> <p>Some of the course material, as well as some of the assessment questions, would require minor adaptations to the South African context.</p>
<p>B. REACTION FROM THE PARTICIPANTS</p>	
<p>1. Robertshaw's discussions with the students, showed that there was a tremendous amount of enthusiasm for the course and this type of teaching.</p> <p>2. The students found the course fairly easy. The amount of time spent on the course varied from 4-15 hours per week, which was a reflection of their different academic backgrounds.</p> <p>3. The students found that one module per week was a realistic pace to work at.</p>	<p>1. The students were also extremely enthusiastic about this particular course.</p> <p>2. The course stimulated them initially, although by Unit Two, it was clear that many of the students were battling with the mathematics.</p> <p>3. Although the tutor felt that the students were capable of working through the material at a faster pace, the difficulties experienced by many with regards to the mathematics might possibly prevent this.</p>

<p>4. The tutorials were too tutor centred, although the students clearly expected and wanted this type of tutorial.</p>	<p>4. Again, the tutorials tended to be too tutor centred.</p>
<p>C. ASSESSMENT</p>	
<p>1. A test at the end of the trial, showed that most students were performing at an acceptable level.</p>	<p>1. At the end of the trial, a test revealed that 9 of the 16 students would have been performing at a test standard.</p>
<p>2. The following areas of strength and weaknesses were noted:</p> <ul style="list-style-type: none"> • Considerable difficulty with interpreting mathematical word problems. • Those mathematical problems that were easily identified, for example, the straight forward calculation of density and volume, were done extremely well. • Accuracy in calculations was very good, which indicated competent use of the calculator. • The Earth Science questions were answered well, but the chemical questions were very poorly answered. 	<p>2. Although specific areas of strength and weaknesses were not commented upon, it was noted that the complex calculations required were well handled by those students, who had throughout the course demonstrated competence with respect to mathematics. This reinforced Robertshaw's impression that there were two distinct sub-groups present in the trial; the groups being determined by the level of mathematical understanding.</p>

In summary therefore, Robertshaw concluded the following with regards to the 'Into Science' and 'S102' course.

'Into Science'

With minor adaptations to the material content, Robertshaw sees no reason as to why this course could not be used in South Africa, especially as a preparation for the 'science foundation'

courses. Given the wide academic backgrounds of the possible students who would take such a course, he does suggest that more support would need to be provided. His suggestions include a greater number and variety of assignment tasks and the planning of structured tutorial sessions revolving around each module.

S102

Robertshaw feels that this course is an excellent course in terms of its comprehensive coverage of science. He does have concerns however about the size of the course and feels that many students could be 'overwhelmed' by the amount of material covered. He suggests that the course could be split into two and that the 'Into Science' course could then be incorporated into the beginning of the 'S102' course; the advantages here, would be that the pre-requisite mathematics would then be covered and that those students new to distance education, would then be introduced to the range of science and study skills that such a course demands.

2.4. THE SCIENCE PROCESS SKILLS

One of the aims of this research was to determine whether the 'Into Science' course had promoted the development of the recognised science process skills. This is regarded as being important since many regard the learning and application of science process skills as being one of the most fundamental objectives of science education. Interest in the development of these skills has been apparent since the early 1960's, where "a major emphasis in science curriculum development has been on the process-orientated problem-solving skills" (Shaw, 1983:615).

Although there has been and there still is considerable debate as to what exactly constitutes a

process skill, possibly one of the best classification of process skills which has stood the test of time is that of ‘The Commission on Science Education of the American Association for the Advancement of Science’ (AAAS), which in the early 1960's identified 11 processes considered to be the best representation of problem solving activities. These are:

a) The basic processes:

- observing
- measuring
- inferring
- predicting
- classifying
- collecting and recording data

b) The integrated processes:

- interpreting data
- controlling variables
- defining operationally
- formulating hypothesis
- experimenting

(Gagne, 1970, cited in Shaw, 1983:615)

Gagne saw the above process as being hierarchical in nature, in that the effective use of these integrated processes first requires a thorough mastery of the basic processes. In constructivist terminology, which presently dominates much of the literature concerning science learning today, this is seen as a process of “scaffolding to support the metacognitive demands of scientific inquiry” (Germann and Aram, 1996:775).

Ever since science process skills were identified as being integral to the very nature of science learning, there have been many attempts to develop assessment frameworks which are able to thoroughly and competently evaluate student performance in these scientific processes. These include the following.

- The First International Science Study (FISS).
- The National Assessment of Educational Progress (NAEP).
- The Second International Science Study (SISS).
- The NAEP 1985-1986 Pilot Study. (Germann and Aram, 1996:776)

Another of these assessment frameworks, was that which was developed by the Assessment of Performance Unit (APU) in the United Kingdom.

2.4.1. THE ASSESSMENT OF PERFORMANCE UNIT

The Department of Education and Science in the United Kingdom set up the APU following numerous concerns expressed in the early 1970's with respect to science education standards. The aim of the APU was to “promote the development of methods of assessing and monitoring the achievement of children in school, and to identify the incidence of under achievement” (Damonse, 1996:42).

The APU commissioned a series of surveys of science performance in skills at the ages 11, 13 and 15 from 1980 to 1984. These surveys were based upon an assessment framework which was agreed upon by the team involved, “following a period of consultation with individuals and groups concerned with science education” (APU - Age 15 Research Report No.2, 1984:1). The framework consisted of six categories of scientific activity, given in Table 2 which follows.

Table Two: APU categories of science performance

CATEGORY	SUB - CATEGORY
1. Use of graphical and symbolic representation.	(a) Reading information from graphs, tables and charts. (b) Representing information as graphs, tables and charts.
2. Use of apparatus and measuring instruments.	(a) Using measuring instruments. (b) Estimating physical quantities. (c) Following instructions for practical work.
3. Observation	Making and interpreting observations.
4. Interpretation	(a) Interpreting presented information. (b) Applying: biology concepts. physics concepts. chemistry concepts.
5. Planning of investigations	(a) Planning parts of investigations. (b) Planning entire investigations.
6. Performance of investigations	Performing entire investigations

(Cited in Taylor, 1990)

Examination of this table and the list of the AAAS discussed earlier, reveals a close similarity of the skills that are recognised to be important in investigations and problem solving. Clearly, there is considerable agreement amongst science education experts over what constitute important process skills.

In an article entitled, "APU Science - the past and the future", Paul Black (1990:13-29) examines in length the achievements which have been generated by the APU. These include the following.

- To help establish the process approach in school science.
- To help establish a starting point for other developments in science education such as

a programme similar to the ‘Open Ended Work in Science’ programme.

And importantly for the purposes of this research:

- “Through the establishment of an international reputation, the work of the APU has formed the basis for development programmes in science education in many countries” (p. 14).

This third point is of relevance to this research, since the majority of the questions used in one of the pre-and post-tests, were derived from the APU questions. It was decided to use these questions to determine whether the ‘Into Science’ course could possibly have promoted a development in the students’ process skills, for mainly two reasons. These were as follows.

1. Most of the of questions established by the APU have already been thoroughly validated. As the APU (1984) points out, “every question undergoes four vetting procedures (shredding, small-scale trials, large-scale trials and validation) during which it can be rejected as unsuitable. If considered suitable however, a number of descriptive labels are attached to the question and then it is incorporated into the appropriate sub-category pool” (p. 220).
2. Research conducted on each question, has yielded a considerable amount of statistical information with respect to the answers given. It is hoped that this information will form a basis for comparison to the data that is derived from this research.

2.4.2. SHORT TERM INTERVENTIONS WHICH HAVE PROMOTED THE DEVELOPMENT OF SCIENCE PROCESS SKILLS

When first conceptualising the research design, I was a little sceptical as to the likelihood of a

short term intervention process such as 'Into Science', promoting any significant measurable development. Those studies that I was aware of, such as the "Cognitive Acceleration Studies" of Adey et al. (1989), had taken a number of years before any noticeable changes in the subjects had been observed. Surely therefore, a course conducted over only 12 weeks was not likely to have a considerable effect!

Examination of the relevant literature however, does provide numerous examples of short term intervention processes which have indeed proven to be successful. These include the following.

1. "Teaching and Learning About Human Nutrition: A Constructivist Approach." - This was a constructivism based teaching programme implemented by Banet and Nunez (1997) with 13- and 14- year olds. The programme was conducted over 3 months and the results indicated that the intervention "contributed favourably to the modification of the students initial conceptions" (p. 1178).
2. "Teaching Science Process Skills." - A 28 week intervention programme was used in order to evaluate the effects of teaching science, with a special emphasis on process skill development. The research was conducted by Brotherton and Preece (1996) and the intervention "proved to be particularly effective in promoting science process skills and in raising the Piagetian development level in Year 8 males" (p. 65).
3. "The Processes of Biological Interventions Test", by Germann (1989). Although the main aim of the research discussed in this paper was the development of a measuring tool designed to assess science process skill attainment, the research did make use of a lab strategy known as the "Directed Inquiry Approach to Learning Science Process Skills and Scientific Problem Solving"; the so called "Dial (SPS) 2 Programme"(p. 612). Although no time period is discussed, the strategy is designed to provide rapid feedback

in order to rectify misconceptions and therefore one presumes that the intervention time period is a relatively short one. In this research, comparison of pre- and post-tests did indicate that significant gains had been made.

4. “The Effect of a Process-Orientated Science Curriculum upon Problem-Solving Ability.” In this research conducted over a period of 24 weeks, Shaw (1983) administered 11 modules from the “Science.....A Process Approach 2” curriculum. The results of his research showed that “ the students who had the process-orientated science curriculum scored significantly higher than those students who received a science program emphasising primarily content” (p. 622).

From the examples discussed above therefore, clearly short term intervention programmes are able to lead to a development in process skills. It will consequently be of interest in the conclusions generated by this research, to note whether the ‘Into Science’ course did in fact promote any process skill development over the intervention period.

CHAPTER THREE
RESEARCH METHODOLOGY

3.1. INTRODUCTION

My evaluation as to whether the 'Into Science' course was successful in promoting an improvement in scientific knowledge and skills is an example of research conducted within a positivistic framework since the research is attempting to discover relationships between phenomena, in order to reach a conclusion as to whether or not the intervention being studied is having an effect or not.

The main research instrument that was employed in this evaluation, uses what is referred to as the 'single group pre- and post-test approach' (Scott and Usher, 1996:52). In this approach, the dependent variable is measured before the independent variable (the intervention) is applied. Following the application of the independent variable, the dependent variable is again measured and the amount of change that has taken place, if any, is then determined.

Such an approach to educational research has been criticised by a number of commentators, since many believe that the strong social dimensions associated with education, essentially negate a research approach which is basically empirical in orientation. As Giddens (1984) states: "...the Social Sciences operate within a double hermeneutic, involving two way ties with the actions and institutions of those they study. Sociological observers depend upon lay concepts to generate accurate descriptions of social processes; and agents regularly appropriate theories and concepts of social science within their behaviour, thus potentially changing its character.

This.....inevitably takes it some distance from the ‘cumulative and uncontested’ model that naturalistically - inclined sociologists have in mind” (p. 31, cited in Scott and Usher 1996:54).

More specifically, Campbell and Stanley (1963) discuss a number of criticisms which have been levelled at the ‘single group pre- and post-test approach’. These criticisms include the following.

- **History:** Between the pre- and the post-test, additional change producing events, other than the intervention, may have an influence on any differences attained.
- **Maturation:** This refers to any biological or psychological processes which may have changed over time and also possibly have influenced the difference. For example; growing older, losing enthusiasm etc.
- **Testing:** The pre-test itself could have an effect on the difference. For example, during the intervention, the subject may concentrate excessively on certain topics, since they recall that this particular aspect was asked in the pre-test. This excessive concentration will consequently affect the legitimacy of the results obtained for these areas in the post-test.
- **Instrumentation
(or instrument decay):**

This refers to changes in the measuring instrument which might account for any differences. For example; a subtle shift in grading standards.

Whilst it is acknowledged that these criticisms do pose a very real threat to the validity of the results obtained through such a pre- and post-test approach, it is felt that the research procedures

which were adopted during this particular evaluation, to a large extent reduced the effect of these influences. This will be discussed in more detail during the conclusion to this chapter.

This evaluation also attempts to address the qualitative aspects of research, deemed to be so important by Giddens. During the course of this research, the impressions of the students and their tutors with regard to whether they believed that there indeed had been an improvement in their knowledge and skills, irrespective of what any measuring tool showed, was gauged through tutorial observations, informal discussions and interviews with the students and tutors. These impressions will be commented upon, although to a far lesser extent than the quantitative data obtained, since it is felt that these impressions form an integral component of the evaluation of a course such as 'Into Science'.

3.2. THE RESEARCH SETTING

3.2.1. IDENTIFICATION OF A SUITABLE SAMPLE GROUP

Having decided on the necessity for trialling the OU materials, the team responsible for trialling met very early in the year to formalise plans for the implementation of the trial. It was decided to approach several colleges of education with regard to participation in the evaluation. The reason for identifying education college students as being a 'suitable' sample group for such a trial, rather than incumbent school teachers, was that school teachers had not yet returned from their summer vacation and that even if teachers interested in participating in the trial could be identified, the logistic problems of establishing a suitable sample group in relative close proximity to each other for data collection purposes, would prove problematic. The college students however, would

be able to provide relatively large sample groups with easy access and the students would possibly be more interested than teachers in such an evaluation, as they would benefit directly from the trial by being granted a certificate upon successful completion of the course. This certificate could then be included in their curricula vitae and could also be used as a credit towards the proposed FDE, should they wish to proceed with the FDE at some future date.

Apart from the 'easy access' and 'direct benefit' aspects, it was felt that the diversity of the students at the colleges with regards to the courses that they were taking and their chosen areas of specialisation, would also provide valuable information as to who would be able to 'cope' with the future proposed FDE course. In all likelihood, a sample group of school teachers might be a relatively 'closed' sample group, consisting of those orientated more towards the sciences, whereas a sample group of college students might include those who are less science orientated, and would therefore provide information as to how effective the proposed FDE might be in attracting teachers to the critical field of science education.

3.2.2. PREPARATORY VISITS TO THE COLLEGES

Three colleges of education indicated their interest in participating in such a trial. The characteristic features of each college are outlined in the following paragraphs.

College A

This is a large college situated within a 'township' in northern KwaZulu-Natal and trains teachers for junior and senior primary school education. All the students are African and are of mixed gender. The college staff is predominately African with about 20% of the staff being 'white'.

During the research period, the college was undergoing extensive renovations and therefore the facilities for science education were limited. The college did seem to be fairly well equipped however, possessing adequate scientific apparatus, biological models, charts etc.

College B

College B is located approximately 60 km from Pietermaritzburg in a very rural area. The college trains teachers for junior and senior primary school education. All the students at the college are African and are female. Like College A, the college staff are predominately African with about 20% of the lecturers being 'white'. The college does not appear to be particularly well resourced, although the science equipment and facilities are adequate.

College C

College C is situated in the Durban region and trains both primary and secondary school teachers. The students are from mixed ethnic groups and are of mixed gender. The college staff is predominately 'white' and well qualified. The college is extremely well resourced, possessing impressive science laboratories, equipment, laboratory assistants etc.

Initial visits were made to these colleges where the rationale behind the trial was explained to them and where an outline of the 'Into Science' course was given. A large number of students arrived at these initial briefing sessions (171 at college A, 63 at college B and 23 at college C), and it was at this session that the 'Into Science' pre-test was written. At these sessions, information sheets and registration forms were also given to the students (see appendices 1 & 2), reminders in the form of posters (see appendix 3) were placed on the college notice-boards and the students were given a week to decide whether they wished to voluntarily commit themselves to the course.

The university team then made a second visit to the colleges, where the materials were distributed in return for a R25 deposit (it was felt that this was necessary in order to ensure that the trialled materials were returned in a reasonable condition) and where the procedures for the following twelve weeks were finalised. At this second session, the 'APU' pre-test was written.

3.2.3. THE FINAL SAMPLE GROUP

The final sample group that was involved in the trialling of the 'Into Science' course consisted of the following.

- Sixty eight students from college A. The students were of mixed gender, were mostly in their third year of study and were taking mixed classes with a primary school orientation. Twenty four of the students had biology as one of their two majors, fourteen had physical science and fifteen had biology and physical science as their majors. The rest of the students consisted of nine who were Junior Primary in orientation and six who were Senior Primary, but with history as their main major.
- Thirty six students from college B. The students were all female, were in their third year of study and were specialising in senior primary education. It was compulsory for the students at this college to take the General Science course which was spread over their three year diploma course.
- Twenty three students from college C. The students were in their first year of study, were of mixed gender and were specialising in secondary school education with the intention of majoring either in biology, physical science or both. These students participated in the trial as part of a new college programme which had been incorporated into their

curriculum.

As can be seen from the above information, the sample group did indeed prove to be fairly diverse in orientation and at this early stage it was felt that the data provided by the students, should prove useful in identifying the key characteristics required in order to ensure the successful implementation of the proposed FDE.

3.2.4. CONDUCTING THE TRIALLED COURSE

On the same day that the materials were distributed to the students, the 'Into Science' course at the three colleges began. This meant that the final module would be completed 12 weeks later, where-upon the post-tests would then be administered. At the OU those students who choose to study the 'Into Science' course are given the opportunity to meet a study group and a tutor at least two or three times during the duration of the course (Metcalf and Servant, 1996). The University of Natal however, envisages that in their proposed FDE, tutorials will be held once a week on each respective module in order to provide the necessary support, not only with respect to problems experienced with content and skills, but also to aid the student in a type of learning which will be new to the majority of them. The necessity for these weekly tutorials was also raised by Robertshaw (1995) who stated in his conclusions that he believed that "each module should be supported by a one hour tutorial" (p. 15). Therefore, it was felt that it was important to hold these weekly tutorial sessions in order to gauge their efficacy in this type of learning process and consequently, weekly tutorials were incorporated into the trial. These weekly tutorials as will be discussed later, were also useful in providing myself and fellow M.Ed. student Kitty Sokhela, with a greater opportunity for participant observation.

Since one of the essential questions of this evaluation was whether the students would be able to proceed through the materials at the speed used by the OU, it was deemed important to maintain a time schedule as close as possible to that which is used by the OU. Our original plans therefore, were to conduct the course over the time periods indicated by Table 3 below.

Table 3: Envisaged duration of the trialled ‘Into Science’ course

	College A	College B	College C
Visit 1	13 February	29 January	18 February
Visit 2	25 February	25 February	20 February
Module 1 tutorial	11 March	3 March	27 February
Module 2 tutorial	18 March	10 March	6 March
Module 3 tutorial	25 March	17 March	13 March
Module 4 tutorial	1 April	24 March	20 March
Module 5 tutorial	8 April	31 March	27 March
Module 6 tutorial	15 April	7 April	3 April
Module 7 tutorial	22 April	14 April	10 April
Module 8 tutorial	29 April	21 April	17 April
Module 9 tutorial	6 May	28 April	24 April
Module 10 tutorial	13 May	5 May	1 May
Module 11 tutorial	20 May	12 May	8 May
Module 12 tutorial	27 May	19 May	15 May

Attempts were also made to follow the normal assessment programme of the OU’s ‘Into Science’ course discussed earlier in Chapter Two, except that all four assignments were tutor marked instead of only two being tutor marked and the other two being computer marked. Since the assessment programme is an integral component of the ‘Into Science’ course as it provides a valuable indicator

to the student with respect to their extent of understanding, completion of all four assignments with a mean mark of 50% (this was decided at a joint meeting of all the tutors involved in the trial) would form the basis for the successful 'passing' of the trialled course and for the award of the end of course certificate to the students.

3.2.4.1. FACTORS WHICH RESULTED IN A CHANGE IN TIME SCHEDULE

Unfortunately, the dates indicated in Table 3 became very difficult to adhere to. It soon became apparent that the different dynamics that operated at the three colleges necessitated a readjustment of the schedules and the approaches which had initially been planned. The reasons for these readjustments are outlined in the following paragraphs.

College B

After the fourth module tutorial at college B, the students were involved in protest action against perceived irregularities in the college administration. These protests stretched over a period of two weeks. Immediately after these protests, the students went on their Easter vacations (all were residential). Since each set of 'Into Science' materials was being shared by three individuals who often had no contact during their vacation, it was decided not to continue with the course over this period. Upon their return and with their agreement, modules 5 and 6 were completed over one week and modules 7 and 8 over the following week.

College A

A similar situation was experienced at college A. This time however the staff at the college were protesting and these protests impacted upon the tutorials due to be held for modules 2,3 and 4,

since the suspension of the normal college curriculum meant that many students would not be attending the course over this period. Having anticipated this problem, the college A tutor suggested to the students that the first 4 modules be accelerated, which would result in these modules and tutorials being held over two weeks, rather than the four weeks originally planned. Since the students were involved with very little other college work during this period, they agreed to these suggestions. In addition, as in college B, the students felt that they would experience difficulty doing the course over their vacations, as each set of materials was being shared between three students. Consequently, no work was therefore conducted during this period.

College C

Although there was no interruption of the official college time-table at college C, the course period was still extended for an additional four weeks. The reasons for this extension were;

- (a) during their vacation each set of materials was shared between two students and;
- (b) the course co-incided with their college exams, and it was strongly felt by the students that it was not fair for the 'Into Science' course to impose unduly upon their time needed to prepare for these exams.

Role of college tutors

An additional alteration with regards to our original plans concerned the tutors involved in this trialled course. Initially, it had been decided that the college staff would be responsible for the tutoring and that occasional visits would be made by the university team to these sessions, in order to make observations and collect data. At college A, due to the distance involved, these original plans were adhered to. During our initial visits to the other two colleges however, it was decided that the tutoring sessions would be conducted by the university team, with support being provided

by the college staff. This it was felt would not only provide valuable information with regards to the how the tutorial sessions were proceeding, but would also allow for the two masters students involved in the trial to become thoroughly acquainted with the course materials. Consequently, Dave Bailey became the tutor at college B, whilst Kitty Sokhela was the tutor at college C.

As a newcomer to educational research, these deviations from our original plans concerned me. After reading Scott and Usher (1996) however, my apprehensions were placed into their correct context, with the realisation that educational research, by its very nature, demands flexibility of approach. As Scott and Usher state: “Education as a field of research and theorising is not firmly rooted in any single disciplinary matrix” (p. 34). They argue that the generation of any type of knowledge in educational research has to take place within a knowledge producing community, and that such communities “will display a great variation in their cohesiveness, the strength of their ‘disciplinary matrix’, and the flexibility of the procedures by which they validate knowledge claims”. They continue by stating that: “.....research is not a matter of applying a set of transcendental methods or of following an algorithmic procedure.....One consequence of this is that some activities will be considered appropriate and will function as criteria for validating knowledge outcomes, others will be ‘ruled out of order’ and excluded” (p. 34).

It would appear to me therefore, that whilst wholesale changes to original planned methodologies are clearly inappropriate, one has to be flexible during the course of the research in order to accommodate the necessary changes which will evolve in educational communities as the research proceeds. A failure to recognise such change and a failure to adopt a reflective methodological approach, may ultimately influence the validity of the findings.

3.3. THE RESEARCH INSTRUMENTS

In order to determine whether the 'Into Science' course had promoted a development of concepts and skills, a decision was made to administer two different types of 'pencil and paper' pre- and post-tests.

3.3.1. THE 'INTO SCIENCE' PRE- AND POST-TEST

The first pre- and post-test designed, was totally based upon the 'Into Science' course materials. All 12 modules of the course, including the workbook and the assignment questions, were carefully examined by myself and fellow M.Ed. student, Kitty Sokhela. During this examination, a list of the major concepts and skills that it was thought that the course developed, was compiled. From this list, I then developed a set of questions which it was felt were representative of these concepts and skills taught by the course. These questions were then shown to the research supervisor David Knox, for his considered opinion.

In any study which uses pre- and post-tests as the main research instruments, the need to identify and minimise potential errors and mistakes when designing the research tools is of extreme importance. Under normal conditions, such an identification process takes place by means of piloting the research tools, prior to commencing the research with the final sample group.

Unfortunately in this research, the piloting of the research instruments (both these 'Into Science' pre- and post-tests as well as the 'APU' pre- and post-tests , which will be discussed later) could not take place. As mentioned earlier, during the conceptualisation phase of the research, the

identification of education college students as being a 'suitable' sample group for the study, meant that the research needed to be implemented as rapidly as possible. This was because the college staff felt that from an organisational and planning perspective (particularly college C where it was intended to incorporate the course as part of their curriculum), that any delay in implementation would disrupt their normal college curriculum and therefore they were not willing to accommodate the conduction of the trial at a later date. Under the guidance of the research supervisor therefore, it was decided that to enable the research to go ahead, the trial should be implemented as soon as possible after the official college year had begun. At this stage, the design of the 'Into Science' and 'APU' pre- and post-tests had only just been completed, which therefore prevented any type of piloting from taking place. As the supervisor commented at the time, in some important aspects of the evaluation methods, both the M.Ed. students were having to rely on his judgement, rather than being able to develop methods more thoroughly for themselves.

3.3.2. THE 'APU' PRE- AND POST-TEST

The second set of tests designed were based upon the APU assessment framework, already discussed in Chapter Two, section 2.4.1. The particular aim here was to determine whether there had been an improvement in the recognised science process skills or not. Most of the questions used in this test consisted of questions used by the APU.

Initially, it was felt that there was a good spread of questions across the categories identified by the APU as being representative of the science process skills. All the categories were present in the tests, except for category 6 (performing entire investigations), which was not possible to include because the tests were 'pencil and paper' tests . All but two of the questions were chosen

from the APU question bank. The APU reports outlined the main type of answer given by their sample of British schoolchildren, with the frequencies of response given for each type of answer. It was hoped to compare the information derived from our trial with these British results. The two questions not selected from the APU question bank were questions 1 and 4 of both the pre- and the post-test. These questions were concerned with the categories of observation and symbolic representation, which in our opinion were not suitably represented by any question from the APU questions we had access to.

[The 'Into Science' and 'APU' pre- and post-tests are presented in appendix 4.]

3.4. PRECAUTIONS TAKEN TO ENSURE TEST VALIDITY

As was discussed in the introduction to this chapter, criticisms have been directed at this 'single group pre- and post-test design'. Of these criticisms, possibly the two that may have had the greatest effect in this research, are those of history and instrument decay.

3.4.1. HISTORY

As far as 'history' is concerned, between the pre- and the post-tests the normal college curriculum could also have been teaching the skills and concepts taught by 'Into Science'. Any differences between the two tests therefore could possibly have been attributed to the college-work, rather than to the 'Into Science' course.

Interviews conducted with the students and the staff of colleges A and B towards the end of the course however, indicated that there had been no such substantial overlap of material coverage.

As one of the tutors at college B remarked: “ Yes, I suppose that we could have been dealing with the same things over the last four months, but as far as I can see, the students should have come into contact with this information right from their Standard 5 General Science year, all the way through their college career, anyway. I think it’s safe for you to assume, that if there are any big differences between the two tests, it has be due to ‘Into Science’ ”.

3.4.2. INSTRUMENTATION (INSTRUMENT DECAY)

Particular attention was addressed to this possible effect on the research validity. Exceptional care was taken in matching the post-test to the pre-test. The order of the questions, in terms of what knowledge and skills were asked, remained identical between the two tests and attempts were made to ensure that the actual questions remained virtually identical in context between the two tests as well. All that was changed, were the figures themselves and occasionally, non obtrusive re-arrangements were made in the data presentations, although only to the extent where it was felt that these re-arrangements would not impact to any significant extent on the validity of the tests. (As will be discussed in the following chapter however, as I gained experience with data analysis during the course of the study year, I did begin to realise that some of the ‘APU’ pre- and post-test questions were indeed problematic in several ways.)

Extreme care was also taken in the marking of the tests. Both tests were only marked after the post-tests had been written, in order to ensure that there had been no shift in grading standard between the pre- and the post-test, and further precautions were also taken, in that before the pre- and the post-tests were marked, the scripts from all three colleges were thoroughly mixed up together so that the ‘college labelling’ of any particular script could be prevented.

3.4. QUALITATIVE METHODOLOGIES EMPLOYED

Although the pre-and the post-test results form the bulk of the data analysis and discussion, it was also regarded as important to take cognizance of the impressions of the course formed by the students, and to a lesser extent the college staff. Even if there is not a significant difference between a student's pre- and post-test scores, the student might still feel that they had benefitted positively from the course by developing a greater degree of confidence with respect to their conceptual and procedural understanding of certain aspects of science.

Although a major qualitative analysis and discussion will not be presented in this research report, the following techniques were employed in order to gauge the impressions of the students and staff of the 'Into Science' course.

- (a) Informal discussions with the college staff over the telephone and at the various colleges.
- (b) Informal discussions with the students at the different colleges.
- (c) Participant observation in college B where I was the tutor, and non-participant observation at the other two colleges.
- (d) In addition, at the end of the 6th module at all three colleges, the following semi-structured interview schedule was used with the students:

INTERVIEW QUESTIONS

1. Do you think that the 'Into Science' course has been effective in teaching you new concepts and skills or perhaps reinforcing concepts and skills previously taught to you?

2. How have you found the degree of complexity of the course? Has it perhaps been easier than you expected or have you found the course to be too challenging, in terms of its aims as being that of a general introduction to science?
3. Do you think that this type of learning is an effective method of teaching you science?
4. Your college lecturers have indicated that some of the students have dropped out of the course. Why do you think that this is so?
5. How have you found the weekly tutorials? Have they helped you and do you think that it is necessary to hold them every week?
6. How did you find the assignments?
7. As you proceeded through the course, have you found that you have had to constantly refer back to earlier modules or have you remembered the scientific aspects covered by this course well?
8. Would you consider taking an FDE in science if it was presented in this format? (Bearing in mind that it would be more difficult than the 'Into Science' course and that you would be teaching full time whilst doing this FDE).
9. Do you think that the 'Into Science' course could be accelerated? For example, completing two modules every week instead of one module a week.
10. Do you have any other comments to make?

The above interview schedule was conducted with 7 groups of 4 students at College A, 3 groups of 4 students at College B and 2 groups of 4 students at College C. Although the questions were kept the same at all three colleges, much latitude was given to freedom of response. With their permission, tape-recordings of the interviews were made.

Although the answers to these questions provided me with a more complete sense of how the students actually felt about the course, only their answers to Question One will be reported on in any great detail, since this question has the most direct relevance with respect to my particular research question being investigated.

3.5. DATA ANALYSIS

Following the marking of the tests, the scores for each question and sub-question were entered into a computer spreadsheet file created by the application Quattro-Pro.4.1. The data were sorted and statistically analysed using the statistical functions of the Quattro-Pro programme.

CHAPTER FOUR
ANALYSIS OF DATA AND DISCUSSION

4.1. INTRODUCTION

The data that is presented in this chapter is organised around the following.

- (1) The 'Into Science' pre- and post-test.
- (2) The 'APU' based pre- and post-test.
- (3) The qualitative data obtained.

In order to present a more coherent analysis of the data, each one of the above points will be discussed separately. In each case the data will first be presented, followed by an analysis and discussion of the results obtained. A final summary of these results and the conclusions derived from this research will be dealt with in Chapter Five.

Since the basic aim of this research is to evaluate the 'Into Science' course in terms of concept and skills development, most of the attention in this chapter will consequently be focussed upon the 'Into Science' pre- and post-tests because these addressed directly the concepts and skills in the course. The results obtained from the 'APU' pre- and post-tests and the qualitative data derived, will be used to supplement the 'Into Science' pre- and post-test results and to extend the lines of reasoning and conclusions generated by these results.

4.2. THE 'INTO SCIENCE' PRE- AND POST-TESTS

4.2.1. MEAN TOTAL SCORES

The mean total scores for each college were calculated for those students who had completed the 'Into Science' course. These means and the standard deviations (which are shown in brackets) are indicated by Table 4 below.

Table 4: Mean pre- and post-test scores (percentage) on the 'Into Science' tests (standard deviations are shown in brackets).

	Mean pre-test score(%)	Mean post-test score (%)	Significance of difference
College A (n = 54)	39.3 (14.2)	50.1 (15.1)	p < .01
College B (n = 26)	32.3 (11.8)	46.7 (14.3)	p < .01
College C (n = 22)	43.8 (22.3)	48.4 (20.3)	p < .1
Combined Colleges (n=102)	38.7 (16.3)	49.0 (16.2)	p < .01

An examination of the pre-test results in Table 4 for all three colleges, indicates that the level of scientific understanding before the course commenced was initially weak, particularly so for colleges A and B. Again, as mentioned in previous chapters, this is a damning indictment with respect to the quality of mathematics and science education previously received by the students during their school and college careers, especially when one considers that the questions asked in the 'Into Science' tests (see Appendix 4) cover a level of scientific understanding normally associated with grade six and seven General Science.

At the end of the course, Table 4 does indicate that there was a mean gain at all three colleges, with college B exhibiting the greatest gain. A 't' test for paired scores conducted on these results shows that the differences between the mean pre- and post-test scores were significant at the 0.01 level for colleges A and B and the combined college scores, but only significant at the 0.1 level for the smaller sample at college C.

4.2.2. FREQUENCY DISTRIBUTIONS

Figures 1 to 3 show the individual college pre- and post-test score frequency distributions, whilst Figure 4 shows the combined colleges frequency distributions.

These frequency distributions clearly illustrate the gains that were made between the pre- and the post-test total scores that are indicated by Table 4. The post-test distributions also show a tendency for a bimodal distribution. This seems to suggest that a gap is developing between a minority of students of 'undergraduate ability' who are able to do reasonably well when working on science at a rate which is more highly paced than what they were previously used to, and others who don't seem likely to be able to work and achieve at this more rapid pace. In order to examine this more closely and to determine who exhibited these patterns of improvement or lack of improvement, scatter diagrams of the pre- and post-test scores for each college were plotted.

4.2.3. SCATTER DIAGRAMS AND DISCUSSION

The scatter diagrams of the pre- and post-test scores for each college and for the combined colleges, are shown by Figures 5 to 8 together with the associated Pearson's product moment correlation coefficient.

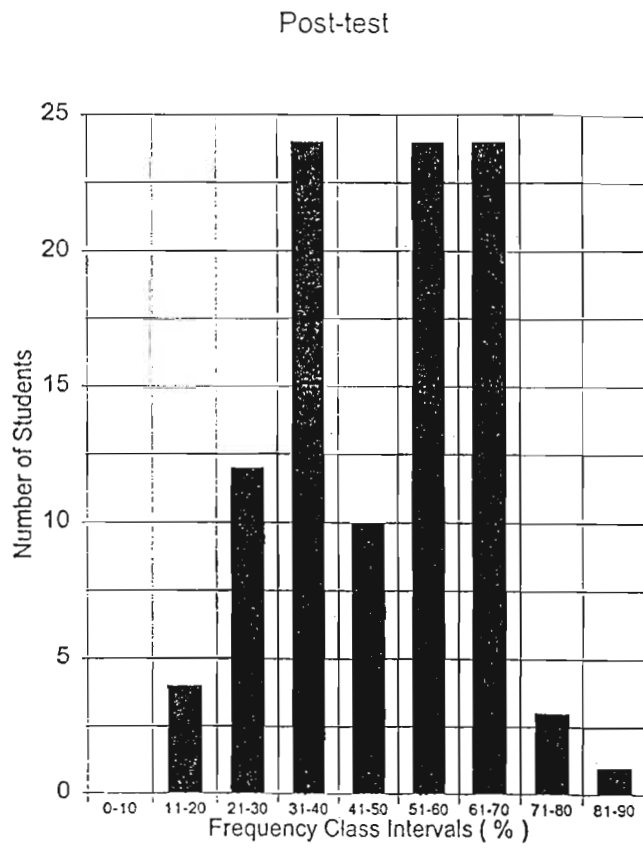
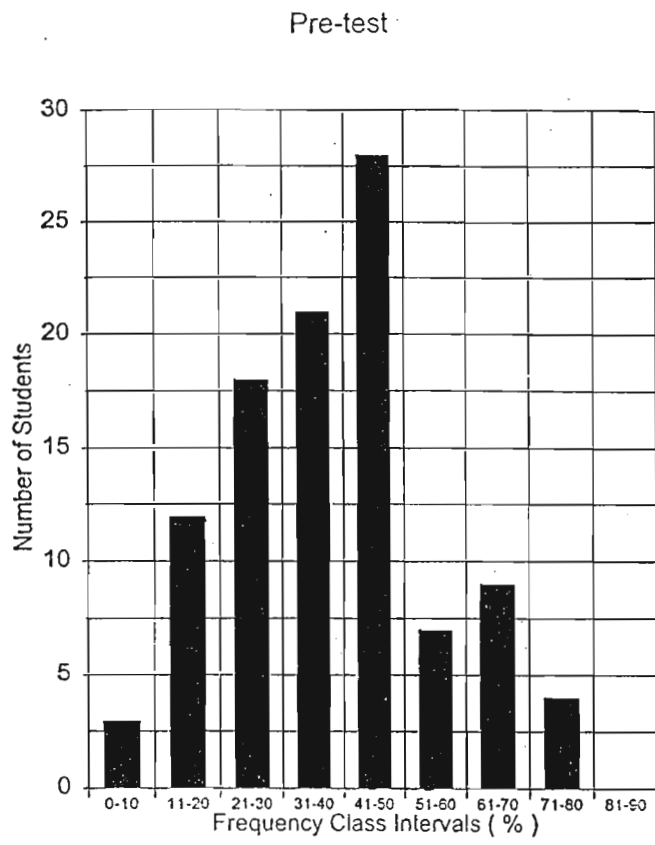
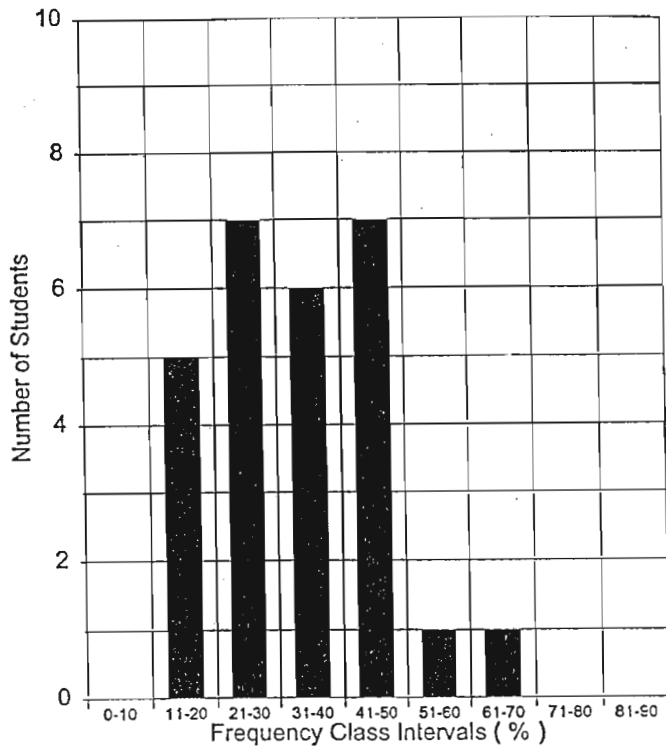

Figure 1: Frequency distribution of scores obtained on the 'Into Science' pre- and post-test for college A.



Post-test

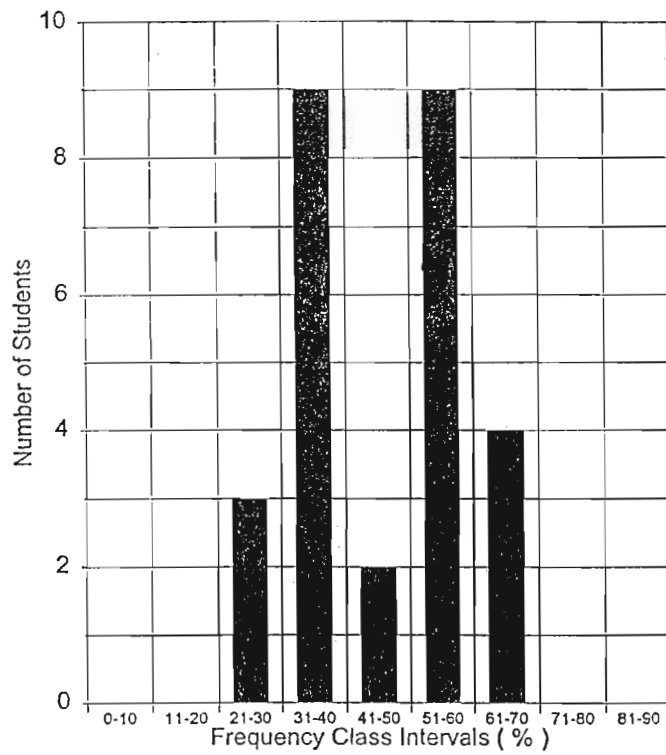
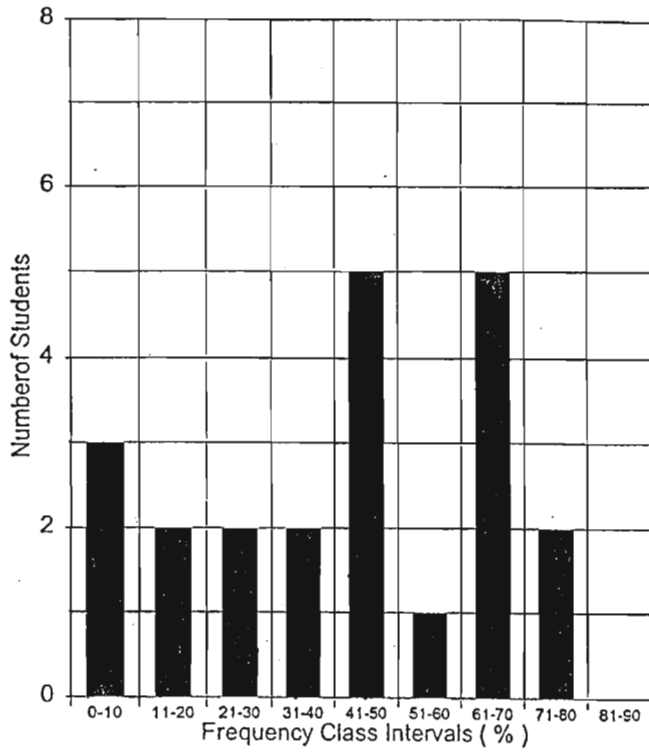

Figure 2: Frequency distribution of scores obtained on the 'Into Science' pre- and post-test for college B.



Post-test

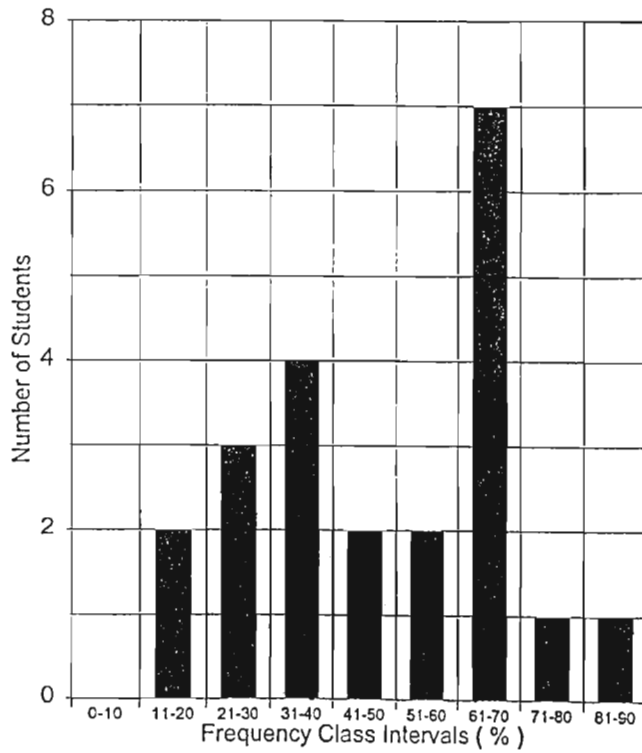
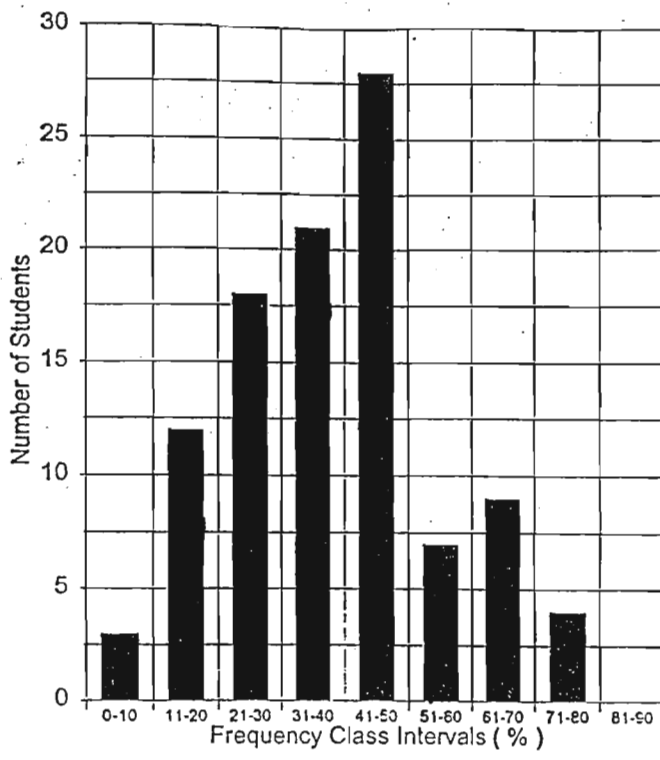

Figure 3: Frequency distribution of scores obtained on the 'Into Science' pre- and post-test for college C.



Post-test

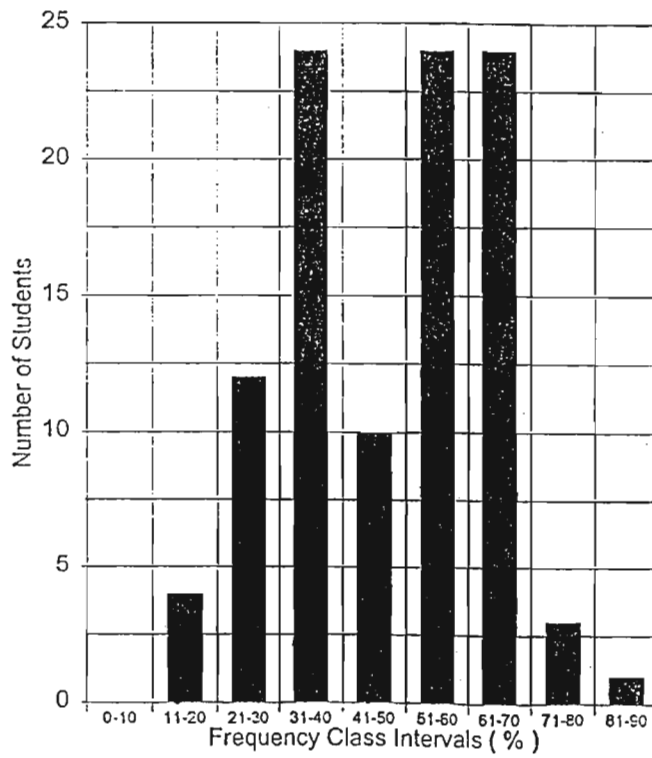

Figure 4: Frequency distribution of scores obtained on the 'Into Science' pre- and post-test for the combined colleges.

College A

$r = 0.72$

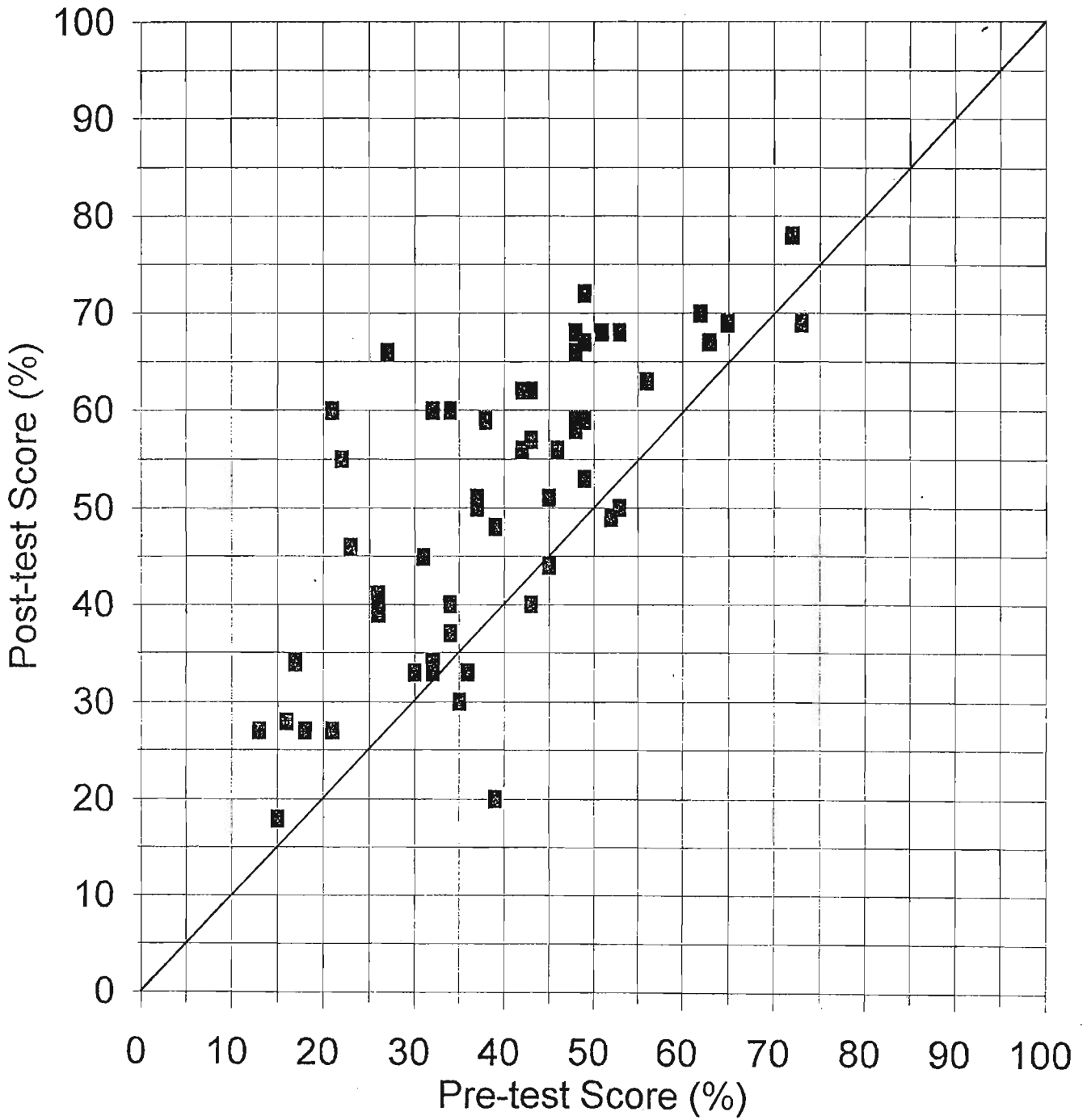

Figure 5: Scatter diagram of the 'Into Science' pre- and post-test scores for college A.

College B

$r = 0.70$

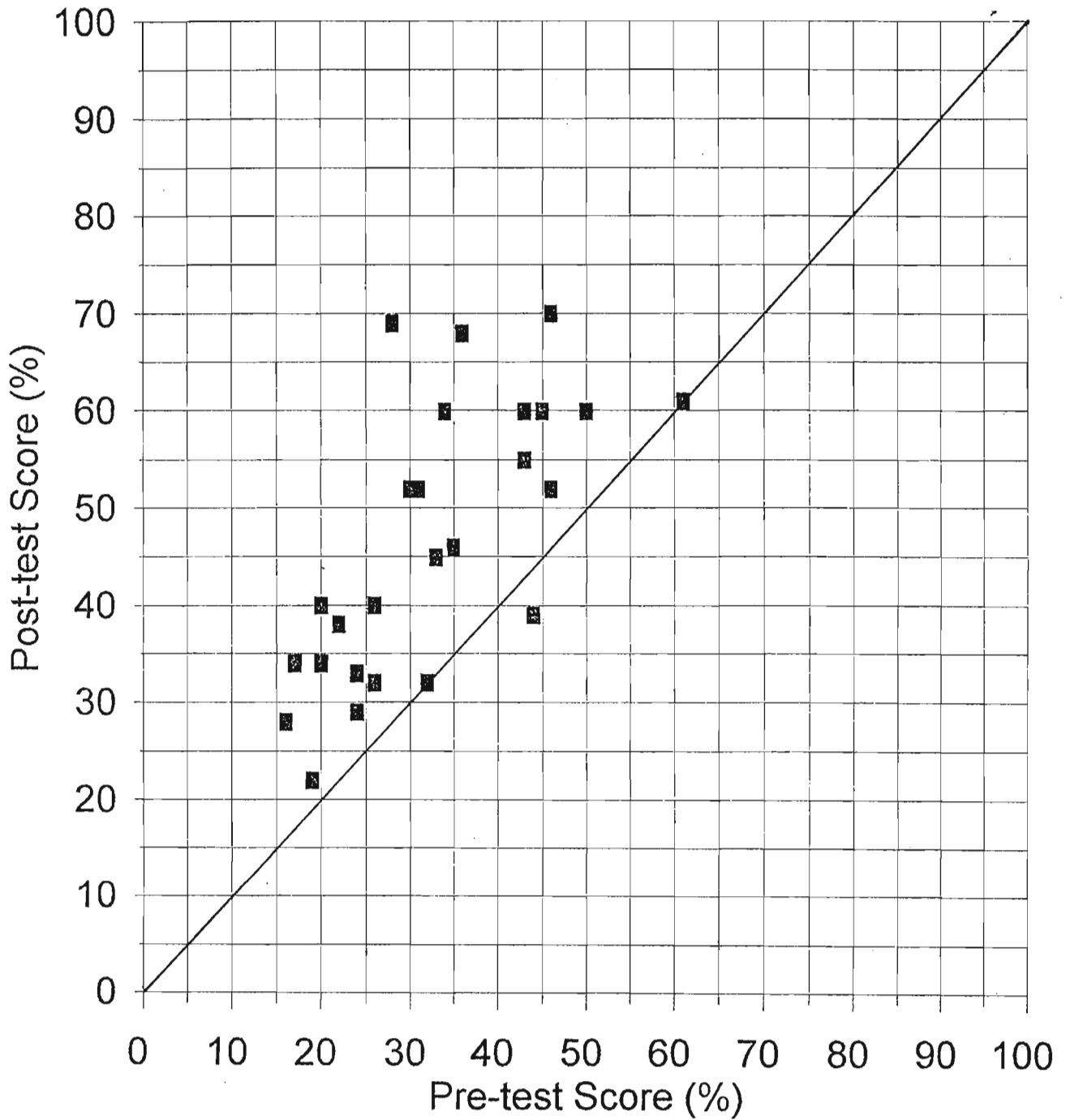

Figure 6: Scatter diagram of the 'Into Science' pre- and post-test scores for college B.

College C

$r = 0.90$

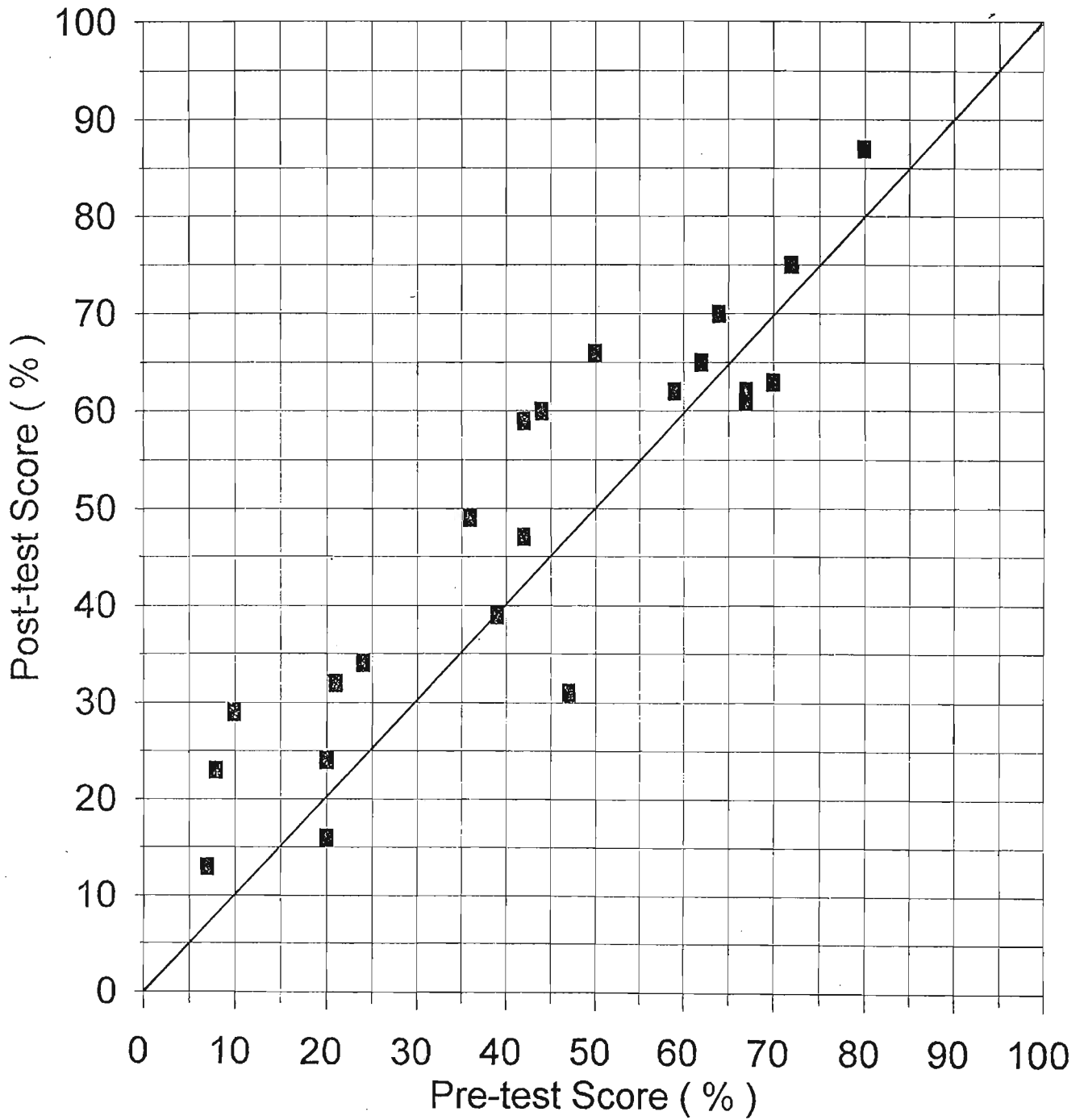

Figure 7: Scatter diagram of the 'Into Science' pre- and post-test scores for college C.

Combined Colleges

$r = 0.72$

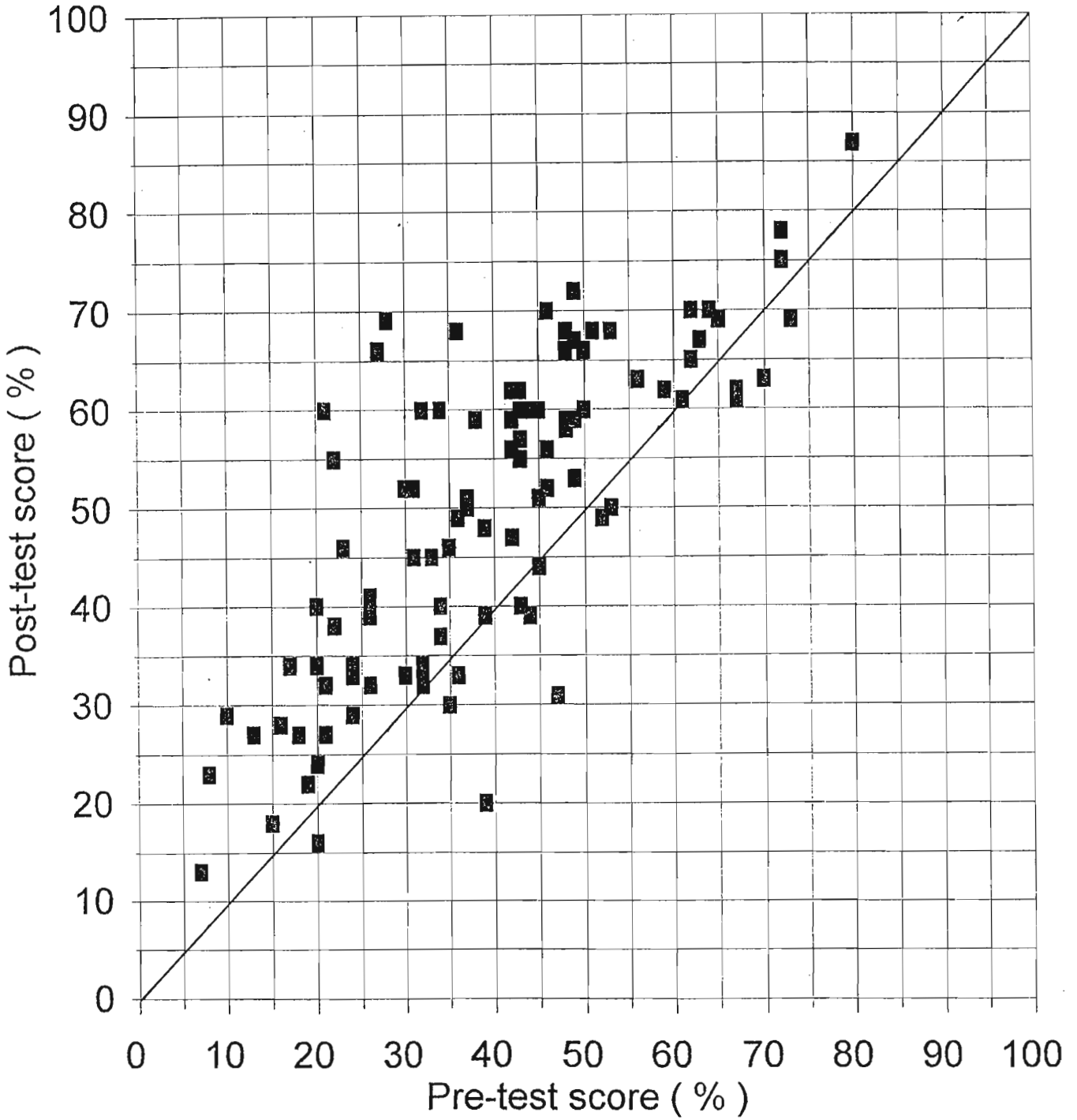

Figure 8: Scatter diagram of the 'Into Science' pre- and post-test scores for the combined colleges.

A closer examination of the scatter diagrams for each particular college shows the following.

College A (Figure 5):

Low pre-test scoring students:

- The five students with less than 20 (percent) on their pre-test total score also have less than 35 on their post-test total score. The eight students with scores ranging between 20 and 30 on the pre-test have post-test scores ranging from 33 to 66, three of the students with scores between 55 and 66.
- The fifteen students with pre-test scores between 31 and 40 have post-test scores from 20 to 60, seven of the students with scores between 50 and 60.

Therefore, of the twenty eight students at college A who received relatively low pre-test scores (below 40), eight of the students improved their post-test scores to above 50, six of the students receiving above 55. Some of the students had consequently improved substantially from their low initial scores. The majority of these low scoring students however, still had disappointingly low post-test scores and possibly do not fall into the group of 'undergraduate ability' referred to earlier; they may be unable to cope with science work which proceeds at a rate more highly paced than what they were previously used to. (Both the students who had improved substantially, as well as the students who did not display so much improvement, will be discussed further when concluding the discussion of these frequency distributions.)

Higher pre-test scoring students:

For those students who had received relatively higher pre-test scores (above 50), the following was observed.

- Of the ten students falling into this group, seven of the students increased their post-test scores, three showing a fairly good improvement from between 50-56 to between 63-68.
- The 3 students who decreased in their post-test scores, exhibited only a very slight decrease in score.

Therefore, the students falling into this particular group are possibly representative of those 'undergraduate ability' students who would be able to cope with science work which proceeds at a rate which is more rapid than what they were previously used to.

College B (Figure 6):

At this particular college, except for one student who showed a decrease in score between the pre- and the post-test and two students whose scores remained the same, all the students showed an improvement in their post-test scores. Eleven of the students improved their scores by between 10 to 19, five by 20 to 29 and two by more than 30. Like college A therefore, some of the improvements were fairly substantial. Again however, a fair number of students at this college (a total of fifteen, which was more than 50% of the students taking the course at the college) had not improved in their post-test scores (which were still 40% and below) to a level which would allow one to confidently predict that these students would be able to cope with the science found in the Open University level 1 'S102' course.

College C (Figure 7):

At college C, there was a far closer relationship between the pre- and the post-test scores, than the relationship which was observed at the other two colleges. No student who obtained a pre-test score of less than 40, obtained a post-test score of above 50. The best improvement in scores

was exhibited by four of the students who received pre-test scores of between 36 and 50; these students increased their post-test scores by a mean of just over 15. Except for one student who decreased from 57 to 46, all the other students whose pre-test scores were 59 and above, received post-test scores which were very similar.

As was mentioned in Chapter Three, college C is an extremely well equipped and well resourced college. In many respects, this particular college is not really typical of the majority of colleges of education found in this country. During casual discussions with one of the college staff members, the distinct impression was gained that fairly strict selection criteria were used to decide whether a particular student would be admitted for study at the college or not. Consequently, the profile of the typical student at this college is possibly not representative of the 'average' type of student that would be found at the other two colleges. Most of the students from college C that were used in this study were probably better grounded in the basic concepts and skills associated with scientific understanding before the course commenced, than what the students at colleges A and B were. This 'better grounding' might be one of the reasons as to why the students at college C obtained a far higher 'Into Science' mean pre-test score, than what was achieved by the students at colleges A and B.

Nevertheless, as Figure 7 shows, there were still some students at college C (seven in total), who obtained very low pre-test scores of 24 and below. (In fact, the three lowest scoring students (7-10) of the entire sample, were at college C.) Again, like the other two colleges, this group of students recorded post-test scores which were also very low; all below 35. This once again confirms that the very weak students did not appear to have benefitted to any significant extent from the 'Into Science' course and possibly would not be able to cope with a more advanced course such as the

level 1 'S102' course, which deals with scientific concepts and skills at a more advanced level.

Combined colleges (Figure 8):

In conclusion therefore, if one examines the total sample group (Figure 8), the following can be seen: If a straight line is drawn onto Figure 8 for the function $y = x$, the degree of improvement of the post-test to the pre-test scores becomes clearly evident. What is certainly striking are the very small number of plots which lie below the line; the distance between and the line and the plots which lie below the line indicating the extent to which the post-test score decreased relative to its corresponding pre-test score.

There can be little doubt therefore that the 'Into Science' course certainly promoted the development of the concepts and skills specifically taught by the course, for the majority of the sample group. However, even though there are clear exceptions as was shown by the discussion of the scatter diagram for each respective college, it is disappointing to note that the degree of improvement shown by the majority of the students is still fairly small. Particularly disappointing, was that only seven of the thirty students who had pre-test scores of 30 and below, had post-test scores of above 40. If one assumes that all the students were trying reasonably hard on the course one would therefore have to conclude that as far as the 'Into Science' course is concerned, such a course is not accessible to all students, despite the course having been designed by the UK 'Into Science' team for students with virtually no prior knowledge of mathematics and science. With regards to the proposed FDE course therefore, a strong case can be made for the inclusion of the 'Into Science' course as a necessary and vital pre-requisite for any student who wishes to embark upon the main level 1 'S102' course. Failure to obtain a suitable pass in the 'Into Science' course will be a valuable indicator to the student that they do not possess the necessary attributes needed for

the successful completion of the proposed FDE course, which will engage with scientific principles at a far greater depth than the 'Into Science' course does.

4.2.4. 'NON SCIENTISTS' INVOLVED IN THE TRIAL

One of the important questions that was identified in Chapter One that needs to be examined by this research, was whether the OU materials would allow access to those teachers who are not science trained but might wish to move into the area of science teaching; a movement seen as very important if the 'cycle of mediocrity' discussed in Chapter One is to be addressed. In order to determine whether these materials can be used for retraining, the progress of the 'non scientists' who participated in this trial needs to be examined briefly.

Unfortunately, the number of 'non scientists' participating in the trial was not a large number. In addition, all of these students were from college A (this being the only college where 'non scientists' had the opportunity to take the course) and this further influenced the extent to which a complete and representative analysis on the progress of these 'non scientists' was able to be done.

The data that is available however is summarised by the table which follows.

Table 5: Matched pre-and post- test scores for ‘non science’ students who completed the ‘Into Science’ course.

Pre-test score (%)	Post-test score (%)	Difference between pre- and post-test score (%)
43	40	-3
42	62	+20
39	20	-19
38	59	+21
36	33	-3
26	41	+15
26	39	+13
21	60	+39
17	27	+10
17	34	+17
16	28	+12

As would be expected, the level of scientific understanding of these ‘non science’ students before the course commenced was extremely weak. The mean score obtained by these students on the pre-test was 29.2% and as Table 5 shows, nine of the eleven students obtained a score of less than 40%.

However, the post-test scores obtained by the students and the difference between the pre- and the post-test scores shown by Table 5, indicate that the level of scientific understanding with respect to the topics which had been taught by the ‘Into Science’ course, had improved by the end of the course, some of the improvements being fairly substantial. The mean score obtained by the students on the post-test was 40.3%, with eight of the eleven students improving upon their pre-test scores;

none of these improvements being less than 10%.

Nevertheless, these improvements in the post-test scores are still disappointing. The mean improvement displayed (11.1%) was only slightly higher than the mean improvement displayed by the entire sample group (10.3%). Since the 'Into Science' materials are examples of materials specifically designed for students with virtually no prior knowledge of mathematics and science, it might reasonably have been expected that the extent of improvement would have been considerably greater than the improvement shown by the entire sample group, if indeed the materials are successful in teaching scientific concepts and skills to students new to the field of science. Although the scores obtained do indicate that the students were not disadvantaged by their initial lack of scientific knowledge, it could be argued that possible reasons for this could have been that the students were more enthusiastic than some of the other students or perhaps they were a group of students who always scored relatively higher. Clearly however, the small size of the 'non scientist' sample group, negates against any real substantive conclusions being generated concerning the impact of these materials on those new to the field of science education and learning. A considerable amount of research still needs to be conducted on this important field of retraining.

In conclusion, during the post-analysis of the interviews conducted with the students at college A (which will be discussed in greater detail at the end of this chapter), it was discovered that two of the students that had been interviewed belonged to this group of 'non science' students. Although their comments cannot be assumed to be representative of the views of all eleven 'non scientists' who participated in the trial, some of the statements that they made do need to be briefly commented upon at this stage.

Both of the students interviewed, felt that their understanding of science had improved considerably through their involvement in the ‘Into Science’ course. Both felt that the course had presented basic science concepts and skills to them in a manner which promoted their understanding of a subject area, which they had previously believed to be an area which was difficult to comprehend. As one of the students stated: “I’ve always been nervous about trying to understand science. Having not done science at school, I thought that it was too late for me to try to improve my understanding of anything scientific. But this course has really shown that science is not that difficult. Although I had to work hard, this course has made me far more confident about science.” (It is interesting to note that this particular student improved upon his pre-test score of 21% to a post-test score of 60%.)

4.2.5. MEAN SCORES FOR DIFFERENT TOPIC AREAS

Table 6 below shows the breakdown of scores obtained by the students for the different topics covered by the pre- and post-tests.

Table 6: Mean pre- and post-test scores by question topic.

Topic	Possible score	College A		College B		College C		Combined	
		Pre	Post	Pre	Post	Pre	Post	Pre	Post
BODMAS	2	2	1.8	2	2	1.9	2	2.0	1.9
Adding negative numbers	2	1.9	1.7	1.3	1.8	1.7	1.9	1.7	1.8
Multiplying negative numbers	2	1.8	1.8	1.5	1.3	1.8	1.6	1.7	1.6

Topic	Possible score	Pre	Post	Pre	Post	Pre	Post	Pre	Post
Multiplying decimals	2	0.6	0.8	0.1	0.5	0.2	0.6	0.4	0.7
Decimal word sums	7	2.8	3.4	2.8	3.2	4.0	3.7	3.0	3.4
S.I. units - length	4	1.7	2.3	2.0	1.9	1.8	2.6	1.8	2.3
Calculating %	4	2.2	2.7	2.4	2.9	1.7	1.4	2.1	2.4
Rounding off	2	1.0	1.5	0.9	1.3	1.1	0.9	1.0	1.3
Significant figures	2	0.3	1.3	0.6	1.1	0.3	1.0	0.4	1.2
Ratios	5	2.8	2.9	2.8	3.0	2.3	2.5	2.6	2.8
Area	4	3.2	3.5	2.7	3.5	2.5	2.5	2.8	3.2
Volume	4	2.3	3.4	2.3	2.9	2.9	2.5	2.4	3.1
Density	4	1.2	1.8	0.3	1.2	2.1	1.9	1.1	1.7
Scientific notation	4	0.8	1.2	0.8	0.9	1.3	0.9	0.9	1.1
Word sums - time	6	1.6	1.4	0.6	1.4	1.5	1.0	1.3	1.3
Basic chemistry	9	3.7	4.5	2.9	3.6	4.4	5.0	3.6	4.4
Graphical skills	15	2.6	5.7	2.3	9.0	5.6	8.1	3.1	7.0
Algebraic equations	8	4.2	4.9	2.1	3.4	4.0	6.0	3.4	4.8
Substitution	4	1.6	2.1	0.8	1.6	1.5	2.4	1.3	2.1

A thorough analysis of this table and the types of errors made by the students, cannot be addressed in any great detail within the parameters of this research which was outlined earlier. Attention therefore, will rather be focussed upon the main problem areas which the 'Into Science' course appeared to have assisted in improving, as well as those areas identified which future course designers and implementers will need to be aware of when final plans are made to introduce the proposed FDE.

Although some of the topics showed no improvement between mean pre- and post-test score (some

of the mean scores actually decreasing!), scores on most of the topics do reflect the mean increase in total score indicated earlier in Table 4, scores on some of the topics increasing fairly substantially. Examples here were the topics of area, volume, density and concepts associated with basic chemistry such as the understanding of terms like atoms, molecules, compounds, etc. Also showing a fairly substantial improvement was the skills based topic concerning the plotting and understanding of graphs.

In many respects, it was gratifying to note the improvements that were made in the areas mentioned above. At the beginning of the course it was immediately perceived through discussions and observations as a tutor at college B, that even the most basic chemistry concepts and simple skills such as the plotting of 'straight-forward graphs', were regarded with great trepidation by the majority of the students. However, by the end of the course, many of these students were beginning to exhibit substantial improvements in their understanding and confidence with respect to these areas. Terms such as 'manipulated variable' and 'extrapolation' became almost part of their 'normal tutorial vocabulary', unlike at the beginning of the course where such terminology was almost never used.

A feature which is clearly reflected by this table, is that many of the students that trialled this course obviously possess mathematical backgrounds which are extremely weak. The use of negative numbers, ratios and answers expressed with scientific notation, showed very little or no improvement. During the tutorials, it was also noted that considerable problems were experienced by many with respect to what normally would be considered to be fairly 'straight-forward mathematics', such as the calculation of percentages, simple algebraic equations and (which for many students was particularly perplexing) the understanding of significant figures.

Although an increased level of confidence was noted towards the end of the course when verbally interacting with the students with respect to this 'simple mathematics', the course designers and implementers of the proposed FDE will have to take cognisance of the difficulties that many of the potential students who undertake the diploma, will undoubtedly experience with mathematics. Considerable support will need to be given here, not only during tutorials but also as far as the course materials are concerned. As pointed out in Chapter Two, Robertshaw (1995) found that the 'S102' course contained many complex calculations which most of his trial students experienced a great deal of difficulty with. These materials therefore, might very well require additional explanation inserts, exercises and assignments, if the students taking the proposed FDE are to be successful.

Other findings that emerged during the Robertshaw trial, were the considerable difficulties experienced by the students with respect to interpreting mathematical word problems. During this trial it was also found that similar such difficulties were experienced, although the results indicated by Table 6 don't reflect the extent of these difficulties, possibly because the questions that were asked in the 'Into Science' pre- and post-tests were not particularly difficult to understand. It was during the tutorials held at college B however, where it became obvious that many of the students were experiencing difficulties with word problems, especially with respect to those word problems which required a greater amount of reading in order to understand what calculations the questions were actually requiring. Although all of the students at college B were second language English speakers, which might have influenced their understanding of these questions, the impression was rather gained that the reason for the difficulties experienced was largely due to this type of question simply never having been practised enough. Again therefore, attention will have to be given in the tutorials and assignments of the proposed FDE to this particular area, since the

understanding of word problems forms an important component of the 'Into Science' and 'S102' courses.

4.3. THE 'APU' PRE- AND POST-TESTS

4.3.1. MEAN TOTAL SCORES AND SCATTER DIAGRAM FOR THE COMBINED COLLEGES

The mean pre- and post-test scores obtained for the 'APU' derived tests are shown below in Table 7.

Table 7: Mean 'APU' pre- and post-test scores for students completing the 'Into Science' course (standard deviations are shown in brackets).

	Mean pre-test score (maximum possible = 35)	Mean post-test score (maximum possible = 35)
College A (n = 54)	15.1 (5.1)	12.7 (4.3)
College B (n = 26)	16.0 (4.2)	15.8 (4.2)
College C (n = 22)	18.3 (6.0)	18.2 (7.7)
Combined Colleges (n=102)	16.1 (5.2)	14.7 (5.7)

As can be seen from this table, the mean scores recorded for the combined colleges was lower in the post-test than in the pre-test. The decrease in college A was fairly substantial, although there was almost no change in the mean score between the pre- and the post-test for colleges B and C. A 't' test for paired scores conducted on these results, shows that the differences between the mean pre- and post-test scores were significant at the 0.01 level for college A, but only significant

at the 0.1 level for colleges B and C.

A scatter diagram of the combined colleges pre-test and post-test scores is shown by Figure 9, together with the associated Pearson's product moment correlation coefficient which was found to be 0.39.

A closer examination of Figure 9 shows the following main trends.

- Of the thirty students who obtained 12 and below on their pre-test scores, sixteen students obtained 12 and below on their post-test scores. Ten students improved their scores slightly from 13 to 16 and four students improved their scores fairly substantially from 19 to 24.
- Of the thirty five students whose pre-test scores ranged from 13 to 17, eight students obtained post-test scores of 12 and below, seventeen students received scores from 13 to 17 and ten students improved their scores to 18 and above.
- Of the thirty seven students who received pre-test scores of 18 and above, eleven students received post-test scores of 12 and below, thirteen students obtained scores from 13 to 17, whilst thirteen students' post-test scores remained above 17.

In conclusion, if a straight line is drawn onto Figure 9 for the function $y = x$, the extent of change of the post-test to pre-test scores can be seen more clearly. What is evident from this plot is the following.

- There appears to be no real pattern of change for those students who obtained pre-test scores of 17 and below. Apart from six students who did improve their scores to some extent, most of the other students' scores remained fairly similar between the two tests, some increasing slightly in their post-test score and others decreasing slightly.

Combined Colleges

$r = 0.39$

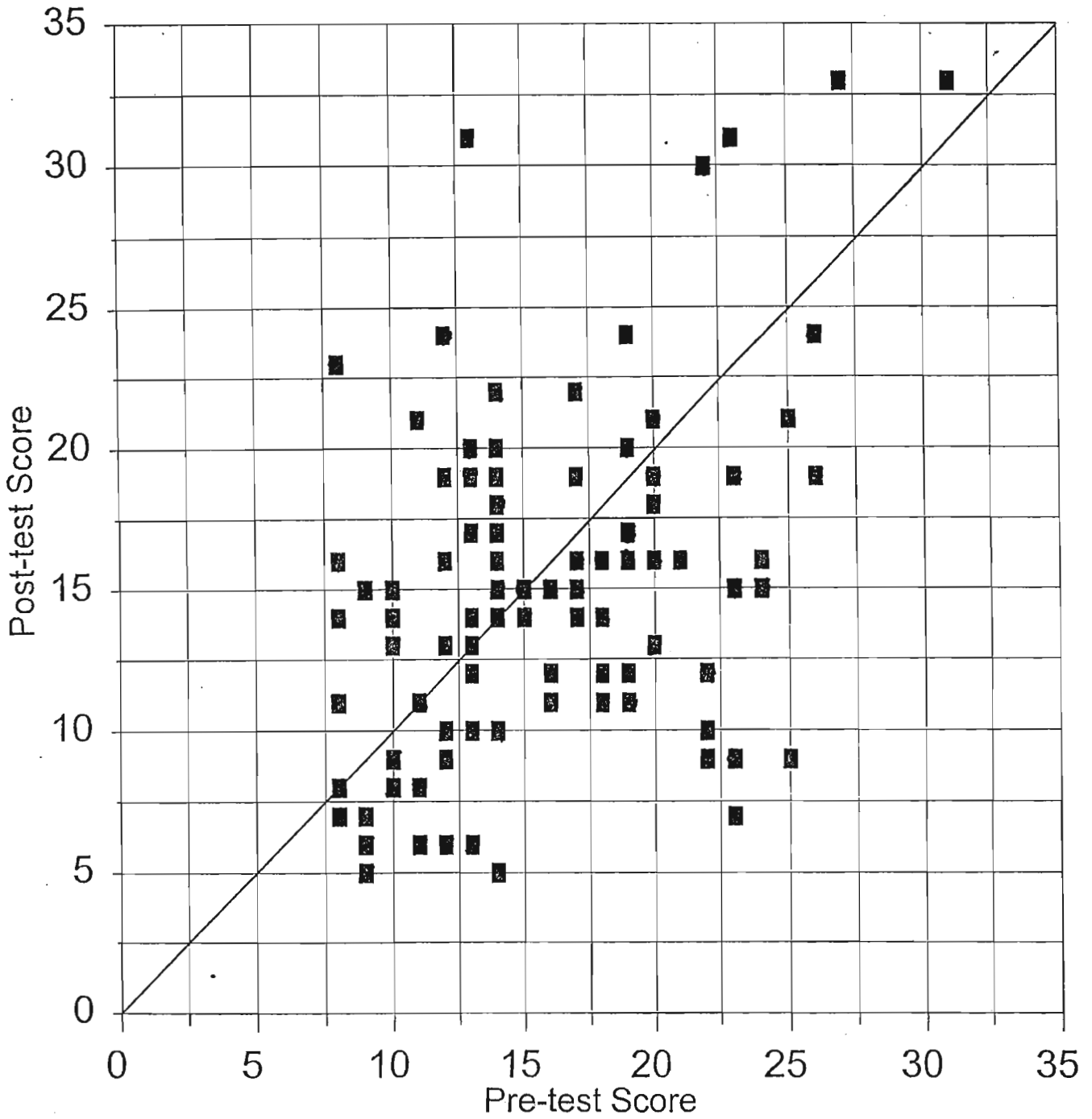

Figure 9: Scatter diagram of the 'Apu' pre- and post-test scores for the combined colleges.

- Many of the students who obtained relatively higher pre-test scores of 17 and above, decreased in their post-test score. The decrease in score for the majority of these students was fairly substantial, twelve of the students decreasing in score by 20% and more. There appears to be no real pattern in terms of this decrease however, since the decrease in scores vary in extent over almost the entire range of higher pre-test scores.

Although disappointing, the results obtained from these 'APU' tests did not come as a particular surprise. Ever since the tests were first set at the commencement of this evaluation, serious doubts had been articulated by this researcher with respect to the legitimacy of these tests. When these pre-and post -tests were marked, the range of answers supplied by the students and the obvious difficulties that they experienced with the contextuality of the questions, made me wonder what these questions were actually testing. The scatter diagram plotted and the moderately positive Pearson's product moment correlation coefficient obtained, further confirmed the expressed doubts with regards to the reliability of these questions. As pointed out by McMillan and Schumaker (1993), "reliability refers to the consistency of measurement, the extent to which the results are similar over different forms of the same instrument or occasions of data collecting" (p. 227). They continue by stating that an acceptable range of reliability for most instruments are coefficients which are close to and above 0.70 (p. 227). The moderate Pearson's product moment correlation coefficient obtained of 0.39 therefore together with the types of mistakes that were made by the students and the difficulties that they had in answering the test questions, indicates that many of the questions used in these 'APU' derived tests are problematic in various ways.

4.3.2. ANALYSIS OF THE SUITABILITY OF THE INDIVIDUAL QUESTIONS USED IN THE 'APU' PRE AND POST-TESTS

4.3.2.1. RATIONALE FOR ANALYSIS

A considerable amount of time has been spent analysing the responses of the students involved in the trial, for each one of the ten questions set in the 'APU' pre- and post-tests. These responses were then compared to the responses generated by the British 'APU' survey, in order to determine whether there were any similarities or differences between the two sets of results. As mentioned in Chapter Three, it was initially the intention of this research to report on these findings. In light of the serious doubts expressed concerning what these questions used in the 'APU' tests were actually testing however, it is felt that a detailed report back on the analysis of the total scores obtained, will serve no real purpose. It has consequently been decided to rather focus on each question, in terms of identifying the features associated with the question which led to the doubts concerning what the question was testing. In this way, it is hoped that the identification of the mistakes that were made in the selection of these questions will be a learning experience for the researcher.

Before analysing the questions, a final point does need to be made about the style of questioning used in the 'APU' post-test. If the test is examined, it can be seen that it differs from the pre-test in that additional sub-questions were inserted, requiring the students to substantiate and elaborate upon some of the answers that they made. This is of course a major deviation away from the format of questioning used in the pre-test and can be severely criticised since it impacts upon the validity of comparing the results of the post-test to the pre-test. For example; having to rationalise upon

the answers that they made, would have affected the amount of time spent on each question and could have resulted in certain questions being 'rushed' and not receiving as much attention as they did in the pre-test.

The tests had already been printed, before the full ramifications of making these alterations in the post-test became apparent. When the tests were administered however, the students were instructed to ignore these additional sub-questions, thereby eliminating these perceived problems discussed above.

4.3.2.2. ANALYSIS OF THE QUESTIONS

For each question, the same format of analysis will be used:

- What process skill was being tested.
- The results obtained from this research, compared to the results obtained from the APU survey which are provided by the APU Science in Schools: Research Report No. 2 for the ages 11, 13 and 15 (APU, 1983). The results are shown as a percentage of those pupils/ students who answered the entire question correctly.
- A discussion of the questions used and the results obtained.
- A final conclusion as to the suitability of the questions used with respect to each particular skill.

QUESTION ONE

Process skill tested

Observation.

Results

1. This research:

Pre-test: 42% Post-test: 29%

2. APU survey:

Not applicable, since this question was not selected from the APU question bank.

Discussion

Although the process skill of observation is regarded as one of the basic skills (Gagne, 1970, cited in Shaw, 1983:615), the results obtained indicated that the students experienced considerable difficulty with the questions selected and that there was a fairly substantial decrease between the post- and the pre-test score.

It is felt however, that this result cannot be regarded as being significant in terms of determining the ability of the students with respect to this particular skill. Initially, no suitable question was found in the 'APU' question bank for this skill and therefore a variety of sources were consulted in order to locate a suitable question. The final two questions selected however, upon post-reflection once the tests were marked, are felt not to be very good representative or comparable questions for this skill. Many students did not even attempt to answer the questions and those that did, experienced great difficulty in expressing themselves with the correct terminology, often making vague unrelated statements. A direct comparison of the questions was also affected by labels being included in the pre-test, but not in the post-test. In retrospect, additional labels in the pre-test such as 'scales' and the inclusion of suitable descriptive labels in the post-test, since some of the body parts are difficult to identify, might have provided for a more accurate assessment in terms of the skill of observation. Apart from the problems discussed above however, it also needs to

be noted that observation skills are highly specific to certain contexts and these questions were certainly testing observation skills in a very definite and particular context - differences between related arthropods. During post-reflection, having now had the time to examine the 'Into Science' materials very closely, it became increasingly obvious that the difficulties experienced by the students in answering this question were hardly surprising, since the 'Into Science' course did not actually include any similar context for observation skills.

Conclusion

The poor selection of questions, negated against an effective assessment as to whether the 'Into Science' course promoted the development of observation skills.

QUESTION TWO

Process skill tested

Use of graphical and symbolic representation. - Reading information from tables.

Results

1. This research:

Pre-test: 94% Post- test: 86%

2. APU survey:

78% of the survey obtained the correct answers for the pre-test

question (APU Age 11 Research Report No. 2, 1983:168). Although testing the same skill, the question used in the post-test was different to the pre-test question (which as will be discussed is highly problematic), and therefore cannot be used for comparison purposes.

Discussion

Clearly for this question and process skill, the students experienced no particular problem. The very high scores obtained however are misleading, since considerable criticism can be directed at the questions that were selected to assess this skill of table reading. These criticisms include the following.

- The question used in the pre-test was far too simple, albeit that the profile of the sample group with respect to scientific understanding was extremely weak. As weak as they are however, college students should still not have experienced difficulty with a question that was principally aimed at eleven year olds by the APU. Although the question used in the post-test was slightly more advanced (chosen from the bank of questions directed by the APU at thirteen year olds), this process question was still essentially very simple in nature and really not suitable for students whose average age was close to twenty one. Both questions, were really only testing specific items of information from tables; ie - finding the correct rows and columns each time. They were not testing discerning trends, patterns, or requiring explanations, etc.
- Also problematic is the fact that the questions chosen were not comparable, since they were selected from APU question banks aimed at different age groups. If the questions are examined, it can be seen that the main difference in comparability between the pre- and the post-test is that the post-test question contains more figures and fewer words than the pre-test question.

At this stage, the reader also needs to be reminded that part (d) of the post-test is an example of one of the additional sub questions inserted that was discussed earlier, and that when the post-tests were administered the students were told to ignore. Clearly, part (d) is noticeably more difficult

than any part of the pre-test and the extensive amount of answering time that would have been spent on this part of the question by the students, would have rendered comparability even more problematic.

Conclusion

The lack of standardisation techniques employed in the choice of questions used, makes it difficult for any substantive conclusions to be made concerning the development of this particular process skill over the duration of this trial. The results do seem to indicate however, that the students were competent with respect to the understanding and interpretation of simple tables.

QUESTION THREE

Process skill tested

Use of graphical and symbolic representation. - Reading information from a graph.

Results

1. This research:

Pre-test: 61% Post-test: 82%

2. APU survey:

67% of the survey obtained the correct answer (APU Age 13 Research Report No. 2, 1983:176).

Discussion

For this question, only the results obtained from the pre-test are directly comparable to the APU results. Here it is interesting to note that the mean obtained by the college students was less than

the APU mean obtained. The main problem area appeared to be part (c), where 47.8% of the students misinterpreted the question. They responded by reading off from the graph the largest numbers (as shown by Pakistan) rather than the largest proportion (which in this case would have been Nigeria and Turkey). The difficulty experienced by the students in this question was not so much a difficulty with graphical representations, but rather a difficulty in understanding what the question was actually asking.

The results obtained for the post-test do appear to indicate a significant improvement. The students answered part (c), the 'proportion' part of the question, far better and this was possibly the main reason for the improvement exhibited. The improvement made however is misleading since it was easier to determine the answers in the post-test question, as when constructing the question the graphical representation of numbers was inadvertently made more 'clear-cut' and more obvious in terms of what the question was requiring, particularly for part (c). This error in graphical representation was not 'picked-up' during the setting of the tests and only became apparent during reflection.

Another anomaly in the question which also became apparent during reflection, was that of the ludicrously high Botswana populations in the post-test. The total population in Botswana is probably less than 2 million, whereas on the chart a total population of about 38 million is shown. This anomaly however would not have influenced the answering of the question since it does not have any affect upon the context of the question. Also, my impression is that the majority of students used in this research would not have even realised that these populations were ludicrously high.

Conclusion

The questions used in the pre-and the post-test were not similar enough to allow for an effective comparison to be made between the two tests in terms of this particular process skill development.

QUESTION FOUR

Process skill tested

In this question a number of skills were being tested.

In 4a: Use of measuring instruments

In 4b: Use of graphical and symbolic representation; ie - representing information as graphs

In 4c: Interpretation of graphs.

Results

1. This research :

Pre-test: 42% Post-test: 73%

2. APU survey:

Not applicable, since this question was not selected from the APU question bank.

Discussion

The results for this question show that there was a significant improvement between the pre- and the post-test. This result does tend to confirm the results shown by the 'Into Science' pre- and post-tests, in that by the end of the 'Into Science' course, the students definitely felt more comfortable with the use and interpretation of graphical representations.

However, if one looks very closely at the wording of the questions used, criticisms can still be

directed at these questions; questions which are considered to be probably the best questions which assess process skill development in this 'APU' derived test. Firstly, what was required for (b) in both the pre- and post-test, was the plotting of a line graph. This should have been made clear to the sample group, since many chose to plot histograms which are not true graphical representations of continuous variables. Interestingly however, when re-addressing this choice of graphical representation, it was found that 84% of the sample group in the pre-test chose to plot a histogram, compared to only 52% of the sample group in the post-test who chose to represent the data by means of this method. This perhaps indicates that the 'Into Science' course was indeed successful in teaching what type of graphical representation would be appropriate to use, when presented with data in a certain way.

Part C should have also made it clear to the students that they were required to use their graphs in order to determine their answers. Many students answered this question by either:

1. Using the measurements they had made in (a).
2. Guessing the answer from information given in the diagrams, which meant that they were using a 'sense of proportional relationships' to determine the answer, rather than using their graphical representation to predict the answer.

Conclusion

Despite the difficulties discussed above, it is felt that this particular question was successful in assessing as to whether the skills associated with graphical representations did improve over the intervention period. The results obtained, complement the results obtained from the 'Into Science' test well.

QUESTION FIVE

Process skill tested

Interpretation. - Describing a pattern and using this pattern to generate a prediction.

Results

1. This research:

Pre-test: 15% Post-test: 17%

2. APU survey:

16% of the survey obtained the correct answers (APU Age 13 Research Report No. 2, 1983:164).

Discussion

This question was possibly one of the hardest used in the 'APU' survey, which can be seen by the low percentage of the pupils in their survey who obtained the correct answers.

The results obtained for the pre- and the post-tests in this research were also very low, with virtually no improvement taking place between the two tests. It was evident when reading through the students' answers, that the majority of the students had virtually no idea as to how to interpret the information that was given in the question. Most of the students did attempt part (a) of the question for both tests, but when examining their answers to part (b) it became obvious that their answer to part (a) possessed a strong guessing component, since most of the explanations that they gave as to how they obtained (a) indicated a total lack of understanding with respect to the interpretation of the information given.

Unlike most of the questions discussed so far, which have been criticised due to the lack of comparability between the pre- and the post-test question, this particular question that was used does appear to be fairly closely matched and therefore comparable. It was interesting to note however as to how the students handled an unfamiliar British flower type such as the 'Snowdrop'. When reading through the students answers, it did become apparent that some of the students were reasoning that the 'snowdrop' would flower during periods not even indicated on the table (ie, June and July, since they associated 'snow' with winter). Since the context of the question should not have been influenced by the example used however, if this line of reasoning was employed in order to answer the question, it still indicates that those particular students were weak with respect to perceiving a pattern in given data.

Conclusion

The results obtained for this question indicate that the skill of describing a pattern and then using this pattern to generate a prediction, was not developed by the 'Into Science' course over the study period. Whilst it is true that the 'Into Science' course did not actually contain any tables or examples similar to what was used in the question, one still would have expected that such a course should have developed this type of non-contextualised process skill to at least some extent.

QUESTION SIX

Process skill tested

Interpreting presented information by using a sense of proportion.

Results

1. This research:

Pre-test: 38% Post-test: 26%

2. APU survey:

53% of the survey obtained the correct answer (APU Age 13 Research Report No. 2, 1983:172).

Discussion

Again the questions used in the pre- and post-test were closely matched, and therefore comparable.

The results obtained by the students in the pre- and post-test were lower than those results obtained by the pupils in the APU survey. The decrease from the pre-test to the post-test is surprising, especially when one considers that in Question Four (the proportion histogram question), the students appeared to be able to recognise and apply concepts of proportion. When reading through their answers to this question however, it was evident that many students simply guessed a response, their answers often showing no understanding at all as to what the question was requiring.

It is interesting to speculate as to why such a 'sense of proportion' was found to be lacking by the students in their answering of this question. The lack of familiarity with British birds should not have influenced the students' responses, since like the previous question, the particular examples used would not have affected the context of the question at all. In their discussion of this particular question, which was also answered poorly by the pupils in the APU survey, Donnelly and Welford (Science at Age 15: A Review of APU Survey Findings 1980-84, 1988:71) believe that the difficulties experienced by their survey pupils was due to attempts to 'generalize' the data. They believe

that if data is presented in an ordered form then the more routine generalized skills can be used to extract relationships between variables. If data is presented more randomly however, as is the case in this particular question, the “performance appears to be sensitive to the complexity of the manipulations involved the lowest performance is generally found when complex multivariate data is presented, and pupils are invited to decide which variable is functional in altering another” (p. 71).

If one extrapolates their beliefs to this research therefore, it would appear that the students were able to predict relationships from data consisting of two variables (as seen in Question Four), but were unable to take the extra step of using data consisting of one dependent and two independent variables in order to predict relationships (although as pointed out by my supervisor, this could have been due to the fact that the eggs were not presented in order of size, unlike the plants that were used in Question Two). Donnelly and Welford hypothesise that this could be due to an “innate cognitive difficulty”, but also state that it is “doubtful whether such variable handling tasks receive attention in normal science education practice” (p. 72). The students in this research therefore, had probably never received such attention during their scholastic and college careers and certainly the ‘Into Science’ course did not focus to any great extent upon the development of the understanding and use of multivariate data and did not contain any comparable tables of data or examples similar to what was used in this question.

Conclusion

The results obtained for this question show that this skill of interpreting presented information by using a sense of proportion, was not developed over the period in which the ‘Into Science’ course was conducted. The weakness in this area, is possibly due to the lack of understanding

and use of multivariate data.

Question Seven

Process skill tested

Interpretation - Application of scientific ideas to specific situations.

Results

1. This research:
Pre-test: 47% Post-test: 43%
2. APU survey: 37% of the survey obtained the correct answer (APU Age 13 Research Report No 2, 1983:171).

Discussion

Of the questions discussed so far, this question is probably the best in terms of the close similarity of the question in the pre- and the post-test. The results show however that there was no improvement at all in the answering of this question. This is a very disappointing and somewhat surprising result. Although the question is biological in nature and depends upon an understanding of respiration and photosynthesis, this understanding is still very basic. It is difficult to believe that the majority of the students had not encountered the topics of respiration and photosynthesis at some time in their college or school careers, especially at the simple level of understanding required by this question. In addition, the 'Into Science' course also specifically deals with these topics (Module 7: Living Material, p.18-20), and therefore the post-test result is particularly disappointing.

The results of this question possibly exemplify the fact that many of the students involved in this

research, had really only been required in the past to simply recall concepts, facts or statements associated with topics such as photosynthesis and respiration. When asked more challenging questions which require a transfer of this conceptual knowledge to the understanding of experimental situations, difficulties arise. This was certainly seen in their answers to part (b) of this question, where many of the students were unable to explain the reasons as to why they chose a particular tube in part(a).

Even though the 'Into Science' course attempts to apply scientific ideas to different experimental situations in virtually all of the twelve modules, perhaps it is optimistic to believe that a short term intervention course such as the 'Into Science' course, would be able to significantly impact upon and change years of understanding generated only through conceptual knowledge. A greater diversity of illustrations and applications on an experimental level might be needed for a longer time period, in order to generate more sophisticated levels of understanding; even in relatively simple questions such as this particular one.

Conclusion

The poor pre- and post-test results obtained, indicate that difficulties are experienced in even simple experimental situations when the level of understanding requires anything more than just the recall of conceptual knowledge.

The remainder of the questions used in these 'APU' pre- and post-tests, like the previous question, are concerned with the understanding of experimental situations and the application of this understanding. The reasons articulated in the last question therefore, as to why experimental or investigation type questions are not answered well by these students, needs to be borne in mind

by the reader as Questions Eight, Nine and Ten are discussed.

QUESTION EIGHT

Process skill tested

Planning of investigations. - Identification of the independent variable.

Results

1. This research:

Pre-test: 45% Post-test: 21%

2. APU survey:

63 % of the survey obtained the correct answer (APU Age 15 Research Report No 2, 1983:110).

Discussion

For this question, the pre- and the post-test question essentially remained the same; the animals and food type involved being the only variables that changed. Again however, like the previous question there is a decrease in the post-test score, although in this question the decrease is a fairly substantial one. It is not easy to determine as to why there was such a significant decrease in the scores. If the pre- and the post-test questions are examined closely however, reasons can be put forward as to why this decrease might have taken place.

For both the pre- and the post-test question, it is possible to obtain the correct option on a 'common sense' approach if one is familiar with either feeding poultry - a diet without corn just doesn't look balanced, or cattle - to feed the cattle only supplement is absurd. The post-test question however,

is characterised by being slightly more 'wordy' than the pre-test question is and does use slightly more complicated terminology; the students might not have even known what a supplement is. The language used in the post-test question therefore, might have influenced the answering of this question by students who were second language English speakers and this could explain the lower result obtained - a result which is very close to one which would be expected if the students had simply guessed their response (25%, since there are four options to choose from). Indeed, an examination of their responses indicated that this was the case, since the responses were more or less evenly spaced among the four possibilities.

Conclusion

Some of the students might have experienced difficulties with the wording and terms used in the post-test question, which could have resulted in the decrease in score from pre- to post-test. Nevertheless, the results obtained for this question do seem to reinforce the conclusions reached in the last question, concerning the difficulties experienced by the students with respect to the understanding of investigation / experimental situations. In hindsight, to have diagnosed in depth the reasons for these difficulties, oral interviews and discussions with the respective students would have proved very useful.

QUESTION NINE

Process skill tested

Planning of investigations. - Identification of the dependent variable.

Results

1. This research:

Pre-test: 72% Post-test: 68%

2. APU survey:

61% of the survey obtained the correct answer (APU Age 15 Research Report No. 2, 1983:112).

Discussion

Like Questions Seven and Eight, this particular question was very similar in context for the pre-and the post-test. A decrease is evident in the post-test result, although the decrease is fairly small.

Again, this question is concerned with the understanding of investigations. Unlike the previous two questions however, the variables given in this investigation are simple to understand and are not influenced by either the necessity to possess subject specific knowledge or by the need to possess the appropriate language skills in order to comprehend more complex terminology. - One would imagine that the activities shown by Question Nine, resemble activities that many of the students would have actually done, perhaps even under non-experimental conditions. The reasonably high results obtained therefore are not surprising, since one would expect that the majority of the students involved in this research probably possessed the fairly basic skills that would have been required in order to answer this question. Indeed, examination of the individual answers given by the students during the analyses of the tests, indicated that those students who did not give the correct response for this particular pre- and the post-test question, generally also gave weak or incorrect answers on most of the other questions used in the tests. These students were therefore the weaker students in the sample group and in all likelihood, would most probably have experienced some degree

of difficulty no matter what question had been asked.

If the course content of 'Into Science' is examined with respect to experimentation, it is evident that throughout course a number of simple experiments are required to be performed. These simple experiments do introduce the concept that in experimental design it is necessary to hold all variables constant, except for that variable which is being manipulated. The 'Into Science' course therefore, should help in developing the process skill of being able to identify a manipulated variable. Due to the simple nature of the pre- and post-test question used however, it is not easy to gauge whether this development took place. An alternative question which is more difficult than the question used in the two tests, yet does not disadvantage the students by possessing complex terminology or requiring subject specific knowledge, might have tested this development better.

Conclusion

The identification of the dependent variable in a basic investigation did not appear to be problematic for the majority of the students. The question asked was too simple however and a more advanced question associated with this skill should rather have been asked, in order to evaluate whether there had been any development in the skill of identifying dependent variables.

QUESTION TEN

Process skill tested

Interpretation. - Interpreting presented information. More specifically, evaluating an experiment and generating the correct measurement procedures.

Results

1. This research:

Pre-test: 18% Post-test: 19%

2. APU survey:

28% of the survey obtained the correct answer (APU Age 15 Research Report No. 2, 1983:118).

Discussion

The results obtained for this question are again exceptionally low; the post-test score being the lowest score recorded for any of the post-test questions.

A thorough analysis of the answers indicated that nearly half of the students tested (49) had virtually no idea as to how to determine the correct answer, many clearly not even understanding what the question required. When one considers that the 'water holding capacity of soils', is part of the Grade Eight General Science syllabus, these particularly disappointing scores for college students become even more distressing. Clearly the students had never seen experiments of this type before, even though they are fairly routine and should have been encountered during Grade Eight or when studying edaphic factors affecting ecosystems during Grade Ten Biology.

It should be noted however that the question asked does differ from the previous three questions, in that Questions Seven to Nine required only a 'multiple-choice' response, whereas this particular question required the students to rationalise and explain the choice that they made, and it was in this explanatory part of their answer where it became obvious that the students were unsure as to what the question was asking. It was also interesting to note that even though the initial

part of the question required a 'multiple-choice' response (steps 1-5 being used instead of A to E), 28 of the students failed to indicate what step they had chosen. More than 25% of the students therefore, were not comfortable with a change in question format which differed from the normal 'lettered multiple-choice' format which they had become used to over their years of being tested.

Conclusion

The results again indicate the difficulties experienced by the students in interpreting experimental situations, especially if the experiments have not been encountered before and if the questioning format used differed from the normal format. Again however, as was discussed in previous questions, the fact that the 'Into Science' course did not specifically contain such experiments or similar type questions, meant that it was not likely that the 'Into Science' course would have promoted the development of such a process skill in any case.

4.3.2.3. GENERAL COMMENTS AS TO WHAT WAS SHOWN BY THE 'APU' BASED QUESTIONS

Generally, if the 'Into Science' course included some type of 'routine' that helped with a particular 'APU' question, then the performance of the students from pre- to post-test generally improved, otherwise their performance between the two tests did not.

More specifically:

1. Many of the students demonstrated a considerable weakness with respect to the interpretation of information given, particularly if the data was presented in a more random form rather than being in an ordered form. In addition, there was also a lack in the understanding and

use of multivariate data. Since the questions used in the 'APU' derived tests were intended to be diagnostic questions, in order to explore the students' thinking, it would have been useful to have conducted extensive interviews with individual students which focussed on specific answers that they gave in the tests.

2. The transference of conceptual knowledge to the understanding of experimental situations, is another area which proved to be problematic for many of the students. The poor performance by the students on experimental orientated questions, reflects an apparent lack of experience with respect to experimental work, especially experiments where the aim is to 'find out', rather than to 'prove / demonstrate'.
3. How the question was asked, also appeared to influence many of the students' responses. Deviating from the usual format of questioning (for example; choosing a step rather than the normal 'multiple-choice' letter as found in Question Ten), caused many of the students to misinterpret the questions. It could be argued that the primary reason for this lack of flexibility with respect to questioning format, was because most of the students were second language English speakers. The language used in many of these questions however was not that complex and one suspects that the reasons for these difficulties that were experienced, is simply due to the fact that many of these students have had limited exposure to a broad and diverse range of questioning formats.
4. One of the more positive aspects that emerged from this research, was the substantial improvement exhibited by the students at the end of the course with respect to their plotting and interpretation of graphical representations. Both the 'Into Science' and 'APU' results

confirmed the observations made at tutorials, regarding the extent of improvement in the students' understanding and confidence of this very important scientific skill.

4.4. QUALITATIVE DATA

As was mentioned in Chapter Three, in order to provide a more complete and holistic overview of whether the 'Into Science' course promoted the development of scientific understanding and the acquisition of scientific skills, it was deemed important to gauge the impressions of the students. These impressions were obtained by means of semi-structured interviews conducted with the students on tutorial visits and are presented below by a series of selected quotes. The quotes are responses to the question: "Do you think that the 'Into Science' course has been effective in teaching you new concepts and skills or perhaps reinforcing concepts and skills previously taught to you?"

- "Yes, definitely! I mean we've done all these things since we were at school, but somehow they've never stuck. The way the information has been presented in this course, I think will always help us to remember it."
- "Yes, especially certain skills. For example, I've always been scared of graphs and of using my calculator. Now I'm much more confident. I realise how easy it is!"
- "Although I was a bit worried at first; I thought there was too much reading. I'm now beginning to realise how informative the course has been. I think the mathematics was taught very well. What was especially nice are all the revision exercises and questions given. They really made us practise and made us feel more confident with what we were

doing.”

- “I think so. I even helped my sister with her homework the other night. The next day she told me that she had understood so well, that the teacher had asked her to explain to the rest of the class.”
- “Yes, I think it was a good course from the reinforcing point of view. The different examples given to us helped us to link different concepts together. At school and at this college, we’ve been taught science in bits and pieces; but now I can see the big picture and how science ideas can be linked together.”

At the beginning of the interviews, the students were urged to be as open and as honest as possible; their sincerity being encouraged through assurances of anonymity. My impressions during the interviews were that the students were indeed being sincere in their responses. What clearly struck me was how affirmative the majority of the students were concerning the course. In many respects, their extremely positive comments were a bit surprising. Being a tutor at college B and a frequent visitor to the other two colleges, I had found it extremely difficult during these visits to gauge the actual impressions of the students concerning the course. Many of the students, especially at college B where I was the tutor, were found to be fairly reserved and reluctant to informally express their views as to how they were coping with the course. It was obvious that the students regarded me as the ‘expert’ and in the ‘tutorial situation’ (especially since a certificate was being awarded at the end!), were not willing to run the risk of revealing any misunderstandings or lack of knowledge concerning certain concepts.

These extremely positive comments that were made concerning their learning experiences and their interaction with the 'Into Science' course, were very encouraging. Clearly, the students felt that they had derived a considerable benefit from the course, despite the 'Into Science' pre-and post-tests indicating that the improvements made in their understanding of scientific concepts and the application of scientific skills, were not that considerable.

That is not to say however that every student was positive. A small number of students did possess reservations about the course, as indicated by the selected quotes below:

- “No, not really. Most of the work covered by this course has been taught to us often before. The course really only repeated what we already knew and sometimes confused us even more with examples that were not South African.”
- “I didn't enjoy the course at all. To me science is doing things, not just having to absorb pages and pages of theory.”

Finally, as illustrated by this last quote, some of the students certainly possessed unrealistic expectations as to what they might gain from doing the course.

- “It was OK. Once I get my certificate, will I be able to become a lecturer at the University?”

CHAPTER FIVE
SUMMARY AND CONCLUSIONS

5.1. INTRODUCTION

In Chapter One, reference was made to the original aims of the 'Into Science' course designers. One of these aims was the intention to promote the development of scientific and mathematical understanding, both conceptually and procedurally, by means of a thorough yet relevant introduction to all the major scientific disciplines. In this final chapter, an attempt will be made to:

- (1) assess to what extent this development was achieved by the students who participated in this trial of the 'Into Science' programme, by providing a concise summary of the findings which emerged from this research, and;
- (2) discuss the implication of these findings in terms of the successful implementation of the proposed FDE.

5.2. SUMMARY OF THE MAJOR FINDINGS THAT EMERGED FROM THIS RESEARCH

- (1) An analysis of the 'Into Science' pre- and post-test results, indicate that for the majority of the sample group, the 'Into Science' course was successful in promoting the development of the concepts and skills that were specifically taught by the course. The extent of improvement for many of the students however was disappointing, considering that the 'Into Science' team had specifically designed their materials to be accessible to a diverse range of learners irrespective of their background in terms of initial science training.

The tendency towards a bi-modal distribution for the post-test score frequency distributions, also seemed to suggest that a gap was developing between a minority of students of possible 'undergraduate ability' who were able to cope with science taught at a rate which was more highly paced than what they were previously used to, and others who don't appear to be able to cope with this more rapid pace. As far as the proposed FDE is concerned therefore, the suggestion is that the 'Into Science' course should be made a necessary pre-requisite for any student who wishes to proceed with the main level 1 'S102' course. Since the 'S102' course deals with scientific concepts at a far greater depth than the 'Into Science' course does, if the student has experienced difficulties with the 'Into Science' course and has failed to successfully complete the course, this student should not be permitted to proceed with the 'S102' course.

- (2) In the introductory remarks of this research discussion, the point was made that in order to address the desperate need for an increase in the number of qualified and skilled science teachers, access routes need to be provided for the movement of teachers not initially qualified with respect to science into the area of science teaching. Unfortunately, the number of 'non scientists' participating in this trial was very small and therefore this important area of retraining could not be fully explored. The results that were obtained however, showed a close correlation with the results obtained by the total sample group in that there was an improvement in the level of scientific understanding by the end of the course, but that this improvement was not a considerable one. Again, the small extent of this improvement reinforces the conclusion that these materials are not actually accessible to all when presented at the standard OU speed.

Interviews conducted with two of these non scientists however, indicated that the materials were successful in helping to remove the ‘mystique’ which they had always associated with science related fields. Both of these students completed the course feeling far more confident with respect to the subject field of science in general. In a sense therefore, even if not supported by quantitative measurements, the promotion of confidence in an area which was previously considered to be difficult to comprehend, is a positive endorsement of these materials. After all, greater confidence promotes greater motivation and as pointed out by Zimmerman and Martinez-Pons (1988): “Students who are highly motivated tend to believe in their own capabilities, are able to set realistic goals for themselves, and are able to use various cognitive and metacognitive strategies to achieve these goals” (Cited in Ayayee and Saunders, 1998:53).

- (3) As far as the different topic areas that were tested in the ‘Into Science’ pre- and post-test are concerned, scores obtained on these topic areas do indicate a substantial improvement in some of the areas tested. These include the understanding and application of scientific topics such as area, volume, density and concepts and terminology associated with basic chemistry such as atoms, molecules, compounds, etc.

One of the areas which exhibited a substantial improvement, both in scores obtained on the ‘Into Science’ and ‘APU’ derived pre- and post-tests, as well as the increasing confidence observed over the duration of the tutorial sessions conducted at college B, was in the important skills based area concerning the plotting and understanding of graphical representations. At the beginning of the course, it was obvious that many of the students involved in this research possessed very little understanding with respect to the plotting

and interpretation of even simple line graphs. Since graphical representations are one of the most fundamental techniques used in science in order to indicate relationships between variables, this lack in understanding was of some concern. By the end of the course however, as indicated above, noticeable improvements had been made. As remarked by one of the students at college B: “Graphs for me used to have no meaning. Now I can see why they are so useful. A good graph almost paints a picture for you.”

- (4) One of the major problems identified by Robertshaw in the SAIDE trial of the ‘Into Science’ course materials concerned the area of mathematical understanding, which some of the students in his trial experienced considerable difficulty with. During our trial of the materials, it was initially obvious that many of the students involved also possessed similar such difficulties. Even ‘straight-forward’ mathematics, such as the calculation of percentages, the use and understanding of algebraic equations and the use of mathematical substitution rules, the understanding of significant figures, the use of negative numbers, rounding-off, ratio’s, the multiplication of decimals and answers expressed with scientific notation, were shown by the pre-test results as well as by observations made at the three colleges, to be poorly understood and applied.

Although the post-test results did indicate an improvement in some of these areas, in most cases the improvement was not considerable, with many of the areas showing no improvement at all. Any distance education course therefore, which requires the understanding and application of mathematical principles in some depth, such as the proposed FDE will require, will have to possess ‘support structures’ incorporated into the course which will focus upon the mathematical areas required to be understood. Such ‘support structures’ should

include attention upon these areas in tutorials, additional assignments which specifically focus upon these areas, additional explanatory inserts incorporated into the materials sent to the students, etc. What will be required as far as the proposed FDE is concerned therefore, is that the materials will need to be carefully scrutinised with respect to all the mathematical areas covered by the course and the necessary 'support structures' then established and put into place before the course commences.

- (5) The results obtained from the 'APU' derived pre- and post-tests, which were designed in an attempt to determine whether there had been any development in the recognised science process skills, were extremely disappointing. In all three colleges there was a decrease between the mean pre- and post-test scores, although the decrease was only really significant at college A, college B and college C showing very little change. A scatter diagram plotted for the combined colleges pre- and post-test scores, shows that no real pattern was discernable for the change in scores obtained between the two tests. This was confirmed by the associated Pearson's product moment correlation coefficient which was only moderately positive.

The disappointing results obtained came as no surprise, since before the tests were even written, doubts had been expressed concerning the validity of some of the questions that were used. Because of these doubts concerning what the questions were actually testing, it was decided that it would be more useful to focus on each question and to try and identify any possible characteristic features of these questions which might have led to these doubts, rather than to analyse the scores in detail.

Some of the answers to the questions however, provided some interesting feedback and did allow for certain conclusions to be reached. These included the following.

- The students' answers to the graphical questions, confirmed the results obtained from the 'Into Science' pre- and post-tests, in that a considerable improvement was exhibited by the students with respect to their interpretation of graphical representations and to their plotting of graphs.
 - Problems were experienced by the students in using quite simple data, if the data was presented in a mixed rather than ordered arrangement and if it was multivariate.
 - The application of conceptual knowledge to experimental situations was also handled very poorly by the students. At college B, when experimental work was conducted, immediate interest and enthusiasm was displayed by the students and this tends to suggest that the students had come into little contact with experimental work over their years at school and college.
 - The problems experienced by the students when having to answer questions which were posed in a format which differed from that which they were used to, indicated that the students had not come into contact with a range of questioning formats during their years of study.
- (6) Finally during semi-structured interviews conducted with the students at the three colleges, 11 of the 14 students interviewed were extremely affirmative about the course. Many felt that aspects of the 'Into Science' course had succeeded in developing their understanding in those areas that they had previously experienced difficulty with. Many of the students had also clearly enjoyed the course and many expressed enthusiasm concerning this type of learning format and indicated their interest in pursuing a course such as the proposed

FDE, should the opportunity present itself to them at a later date. Although negative comments were made, these comments tended to be restricted more towards the design of the materials and the British orientated context of the questions, rather than the scientific areas and topics dealt with by the materials. [These perceptions and viewpoints of the materials are discussed in far more detail by Kitty Sokhela, who was also involved in the trialling of the 'Into Science' programme by evaluating the impressions of the students and tutors involved in the trial (see Sokhela, 1998).]

5.3. SOME CONCLUDING REMARKS

It is the opinion of this researcher that the 'Into Science' programme could be successfully used in South Africa, particularly as a preparatory course for the main level 1 'S102' science course.

The results obtained from this research do indicate that a course based upon the United Kingdom Open University materials, which the proposed FDE envisages doing, is likely to be successful for the following reasons.

- Despite the extent of improvement being fairly small, the majority of the students nevertheless still displayed an improvement in the concepts and skills which were specifically taught by the trialled 'Into Science' course.
- The students involved in the trial were extremely enthusiastic and positive about the materials and about the type of teaching and learning (ie; distance and independent learning but with contact through regular tutorial sessions), that would be required by the proposed FDE.
- The few 'non scientists' involved in the trial, indicated that the materials were successful

in establishing a greater degree of confidence in them, with respect to a subject area that they had always believed to be very difficult.

These points confirm the findings of Kitty Sokhela (1998), who in the conclusion to her dissertation states that: “It is the conclusion of this researcher that ‘Into Science’ can be used in South Africa. This research has proved that the students who participated in this study did not have a problem with English used in the materials, they did not have a problem with the Independent learning mode as they were given support in the form of weekly tutorials, and they can cope with the amount of reading that is expected, provided they are given enough independent study period (and time from other commitments)” (pp. 80-81).

Sokhela (1998), and Robertshaw (1995) in his SAIDE trial of the ‘Into Science’ materials, however do stress the necessity for a variety of ‘support structures’ if it is intended to base most of the course upon imported materials. In this report, the need for such ‘support structures’ in the proposed FDE, has also been emphasised. These ‘support structures’ should include the following.

- Because of the obvious difficulties experienced by the students with certain topic areas, especially the difficulties associated with the area of mathematics, the materials will require additional explanations inserts, exercises and assignments in these areas of perceived difficulty. Particular concentration upon such areas will be needed in the tutorials.
- The poor performance by the students on the more experimentally orientated questions, especially those questions used in the ‘APU’ derived pre- and post-tests, indicates the need for support in the experimental and practical area. As pointed out by Sokhela (1998) in her findings: “Students place a low value on conducting practical work, and instead tend to rely on their past experiences” (p. 78). In order to try and promote the transference

of conceptual knowledge to the experimental situation and to develop a greater confidence with respect to experimental work, laboratory sessions should be conducted as frequently as possible during the course. Certainly the 'S102' course requires a considerable amount of experimental work to be done and Robertshaw (1995), suggests various ways as to how access to laboratory facilities could be provided; ie, during 'Winter School' sessions where all the experimental work could be conducted over a short period of time; over a few day long sessions - once a month on a Sunday for example; or before and after the more theory orientated tutorials.

- Other 'support structures' that could be used over the duration of the course would be structures such as telephonic and e-mail help lines, fax facilities, etc.

Although not strictly 'support structures', these final three points are considered to be useful points to bear in mind if the proposed FDE is to be a success.

- As stated by Robertshaw (1995): "It would be useful if a tutorial package was prepared which explained any local equivalents to the topics discussed in the module; for example, the geology of South Africa for Module 3"; and "a glossary of terms would be useful" (pp. 14-15).
- Also pointed out by Robertshaw: "Experiences in course building on 'S102' indicated that students had problems writing science reports and that the absence of written answers in the 'S102' exam might be contributing to this" (p. 20). In the assessment of the course therefore, instead of mainly using 'multiple choice' questions as the United Kingdom Open University does in their course, questions which require written solutions should also be devised and included in order to try to promote and develop this skill of scientific writing.
- As has been mentioned before, in order to indicate to a student that they might not necessarily

possess all the attributes that would be required to successfully complete the entire FDE course, the Into Science course must be included as a compulsory pre-requisite for any student wishing to embark upon the main level 1 'S102' part of the proposed course. The 'Into Science' portion of the course must be examinable and the student must be required to pass this part of the course before being allowed to proceed with the FDE.

REFERENCES

Adey, P., Shayer, M. and Yates, C. (1991). *Better learning. A report from the Cognitive Acceleration through Science Education (CASE) project.* Centre for Educational Studies, King's College, University of London.

Assessment of Performance Unit. (1983). *APU Science in Schools: Research Report No. 2 for the ages 11, 13 and 15.* Department of Education and Science, London, United Kingdom.

Assessment of Performance Unit. (1984). *Studies in Science, APU: Report on the 1981 and 1982 surveys of science performance of 11 year olds in England, Wales and Ireland.* Department of Education and Science, London, United Kingdom.

Ayayee, E. and Sanders, M. (1998). Factors considered necessary for academic success in first year Biological Science courses. In: *Proceedings of the sixth annual meeting of the Southern African Association for Research in Mathematics and Science Education: 52-55.* University of South Africa, Pretoria.

Banet, E. and Nunez, F. (1997). Teaching and learning about human nutrition: a constructivist approach. *International Journal of Science Education*, 19 (10): 1169-1194.

Black, P. (1990). APU science - the past and the future. *School Science Review*, 72 (258): 13-28.

Brotherton, P.N. and Preece, P.F.W. (1996). Teaching science process skills. *International Journal*

of Science Education, 18 (1): 65-74.

Cambell, D. T. and Stanley, J.C. (1963). *Experimental and quasi-experimental designs for research*. Houghton Mifflin Company, Boston.

Cilliers, J., Kirschner, P. and Basson, I. (1997). Towards a new approach to distance education in physics: the first steps. *South African Journal of Higher Education*, 11 (1): 114-121.

Cross, M. and Schoole, T. (1997). Rethinking the future of teacher education in South Africa: the role of partnerships. *South African Journal of Higher Education*, 11 (1): 48-55.

Damonse, B.A. (1996). A report on some tests of standard 6 pupils' performance in General Science at a KwaZulu Natal secondary school, some possible contributory factors, and implications for teachers. *Unpublished M.Ed.dissertation*, University of Natal, Pietermaritzburg.

Donnelly, J. and Welford, G. (1988). Applying science concepts. In: *Science at age 15: A review of APU survey findings 1980-84*. Department of Education and Science, London.

Germann, P.J. (1989). The Processes of Biological Investigations Test. *Journal of Research in Science Teaching*, 26 (7): 609-625.

Germann, P. and Aram, R. (1996). Student performances on the science processes of recording data, analysing data, drawing conclusions, and providing evidence. *Journal of Research in Science Teaching*, 33 (7): 773-798.

Giddens, A. (1984). *The constitution of society*. Polity Press, Cambridge.

Gray, B. (1995). Future directions in science teacher education. *South African Journal of Higher Education*, 9: 47-52.

Hoadley-Maidment, E. (1992). Living in a changing society: The Open University approach to access materials. *Adults Learning*, 7 (7): 175-177.

Johnston, R. (1997). Distance Learning: medium or message? *Journal of Further and Higher Education*, 21(1): 107-122.

Kaye, T. and Rumble, G. (1991). Open Universities: A comparative approach. *Prospects*, 21 (2): 214-226.

Keegan, D. (1990). *Foundations of Distance Education*. London, Routledge.

Khan, M. (1995). Some policy, process and implementation issues facing science education and training in post-apartheid South Africa. *International Journal of Science Education*, 17: 441-452.

Khan, M. (1996). Some research issues and findings concerning funding policy for science and mathematics education in South Africa. *International Journal of Science Education*, 18(5): 511-523.

Khan, M. and Rollnick, M. (1993). Science education in the new South Africa: reflections and visions. *International Journal of Science Education*, 15: 261-272.

Khan, M., Volmink, J. and Kibi, M. (1995). A proposed comprehensive solution to the cycle of mediocrity in science and mathematics education. *South African Journal of Science*, 91: 421-422.

Knox, D.A. (1996). *Discussion document: Proposed introduction of new Further Diploma in Education (science education)*. University of Natal, Pietermaritzburg.

Knox, D.A. (1997). *Discussion document on B.Ed. course*. University of Natal, Pietermaritzburg.

Marker, W. (1991). The Open University UK and teacher education in Scotland. *Open Learning*, 6(1): 23-29.

McMillan, J.H. and Schumacher, S. (1993). *Research in education: a conceptual introduction*. Harper Collins, New York.

Metcalf, J. (Ed.) (1993). *Into Science*. The Open University, United Kingdom.

Metcalf, J. and Halstead, A. (1989). Into Science: Open learning, drop-out and accreditation. *Adults Learning*, 5 (10): 261-263.

Metcalf, J. and Servant, D. (1996). Into Science: Alternative uses of an Open University pack. *Adults Learning*, 7 (7): 175-177.

Moller, V. (1987). *Quality of life in South Africa: Measurement and Analysis*. Pretoria: Human Sciences Research Council.

National Department of Education. (1997). *Policy document of the Natural Sciences, Senior Phase, 1997*, Pretoria.

Ngubane, B. (1996). Science and technology in South Africa: Future directions. *South African Journal of Science*, 92: 5-9.

Perraton, H. (Ed.) (1993). *Understanding educational research*. Routledge, New York.

Pouris, A. (1996). The writing on the wall of South African science: a scientometric assessment. *South African Journal of Science*, 92: 266-271.

Prescott, W. and Robinson, B. (1993). Teacher education at the Open University. In: Perraton, H. (Ed.) (1993). *Distance education for teacher training*. Routledge, New York, 287-315.

Robertshaw, M. (1995). Access into higher education: The use of imported courses in South Africa. *Unpublished report for the South African Institute for Distance Education (SAIDE)*. Johannesburg: SAIDE.

Salmon, C. and Woods, C. (1991). *Colleges of Education: challenging the cliché*. Durban: University of Natal, Education Research Unit.

Scott, D. and Usher, R. (1996). *Understanding educational research*. Routledge, New York.

Sellschop, J.P.F. (1995). A science research policy for South Africa: a view from the tertiary

education sector. *South African Journal of Science*, 91: 551-554.

Shaw, T.J. (1983). The effect of a process orientated science curriculum upon problem - solving ability. *Science Education*, 67(5): 615-623.

Sokhela, N.H.P. (1998). *An evaluation of the 'Into Science' programme and materials designed by the Open University, using perceptions of South African colleges of education students taking the programme*. Unpublished M.Ed. Dissertation, University of Natal, Pietermaritzburg.

Taylor, R.M. (1990). The National Curriculum: a study to compare levels of attainment with data from APU science surveys (1980-4). *School Science Review*, 72(258): 30-37.

Torres, R.M. (1996). Without the reform of teacher education there will be no reform of education. *Prospects*, 26 (3): 447-467.

Waghid, Y. (1996). Can distance education engender effective teacher education in South Africa? *South African Journal of Education*, 16 (4): 205-210.

APPENDICES

APPENDIX 1

INTO SCIENCE

BACKGROUND

The Education Department, University of Natal, Pietermaritzburg, is hoping to offer a new Further Diploma in Education programme from January 1998 to help science teachers to improve upon their understanding of science and how to teach it.

Part of the diploma is a preparatory course called 'Into Science', which introduces students to some basic ideas and principles involved in scientific study, the basic mathematical skills required for that study and the study and reading skills required for independent distance learning.

THIS IS WHERE YOU COME IN

Before offering the diploma, it is necessary to trial part of the material to help answer important questions regarding its usage. This trial is the 'Into Science' course and your taking of the course will help us to answer these questions since as you proceed through the course your progress will be carefully monitored by the University.

WHAT DO YOU GET FROM THIS COURSE ?

Should you pass the course, you will receive :-

- * more confidence with regards to your future teaching of General Science / Biology / Physical Science.
- * an idea as to what good distance materials are like and the type of working strategy you will need to employ for successful distance education.
- * a certificate from the University, which will be a useful asset when you eventually apply for a post.
- * credits towards your F.D.E. in Science Education should you ever decide to pursue it.

LENGTH OF THE COURSE

The course stretches over a period of 10 weeks and consists of 12 modules. The 'standard student' is expected to put in 12 study hours per week, although this will differ from individual to individual. Tutorials will be held weekly in order to assist students in possible problem areas. You are assessed by means of 4 short assignments done during the course.

MATERIALS REQUIRED

Copies of the 'Into Science' material will be provided by the University, although you will need to provide a basic scientific calculator, a hard covered exercise book, a protractor and a compass. For those of you who decide to attempt this course, a more detailed list of the materials required from week to week (most of which will be provided by the college) will be given to you at a later date.

Before you receive the 'Into Science' materials you will need to pay a R50 deposit per person. This money will be fully refunded to you at the end of the course when you hand the materials back in a good condition.

WHAT NOW ?

If you are interested in this course please collect a registration form from your contact person at the College. Read through the form very carefully, complete it and then hand it back to your contact person as soon as possible. You will then be informed in due course as to what the future arrangements will be.

APPENDIX 2

'INTO SCIENCE' REGISTRATION

Please read the following very carefully before you sign it.

I wish to take the 'Into Science' course and, if selected, undertake the following:-

1. Pay the returnable deposit of R50 upon receipt of the 'Into Science' material.
2. Work carefully through each module, answering any exercises in the text, before attending the tutorial session.
3. Complete all the necessary assignments, as well as any other tests set, by their respective closing dates.
4. Answer any questions from tutors or members of the University team who are evaluating the course for the benefit of future students.
5. Return all materials in a good, unmarked condition, for use by future students.

Full name _____

Year of study
and course _____

Date _____

Signature _____

N.B. REMEMBER TO HAND THIS FORM BACK TO YOUR COLLEGE
CONTACT PERSON AS SOON AS POSSIBLE

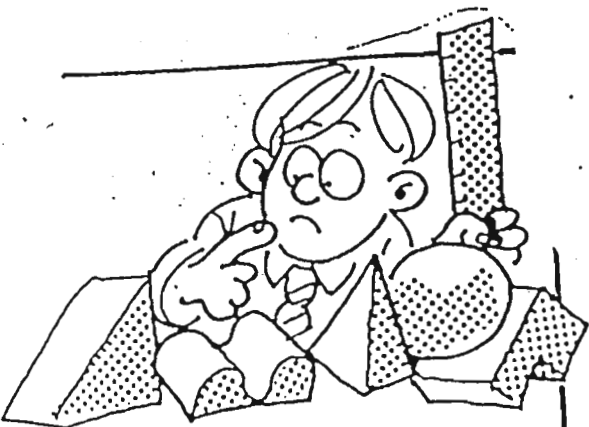

Are you interested
in improving your
scientific skills ?

Why not consider :

INTO SCIENCE

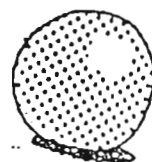

A self-study programme designed to
increase your confidence with
regards to the teaching of basic
science principles.

For further information please collect
a pamphlet from :



APPENDIX 4

THE 'INTO SCIENCE' AND 'APU' PRE- AND POST-TEST.

'INTO SCIENCE' PRE-TEST

'INTO SCIENCE' SKILLS TEST

Instructions:

Duration: 75 min.

Answer all the questions.
Show all your working in your answers.

Material required:

Double page answer sheet
Ruler and a rubber
Protractor
Calculator
Pen and pencil

Question 1

Calculate the following.

(a) $24 + (8 \div 2)$

(b) $-4 + -6$

(c) $(-10) \times (-5)$

Question 2

2.1 Calculate the following to three decimal places, without using your calculator.

8.190×7.55

2.2 25.0g of grass was dried until no moisture remained. Its dry mass was 4.1g. Calculate the following to one decimal place.

(a) What mass of water was there in 25.0g of grass?

(b) What mass of water would have been in 100g of grass?

Question 3

Convert the following into metres, showing your working out.

3.1 42.6 Km

3.2 2000 mm

Question 4

The marks (%) for ten pupils who wrote a standard four General Science test are as follows :

75 ; 85 ; 42 ; 26 ; 65

70 ; 50 ; 38 ; 90 ; 80

Calculate the average mark.

Question 5

5.1 Round off the following figure to one decimal place

6.58

5.2 Express the following to 3 significant figures

1.0557

Question 6

Examine the following rectangle and answer the questions below.

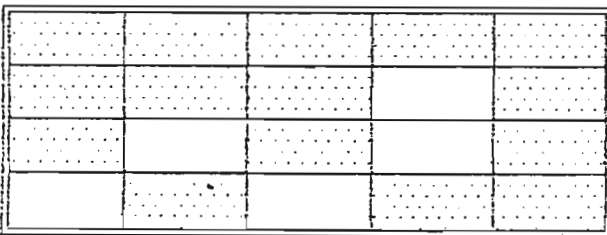

6.1 How many blocks have been shaded in?

6.2 Express the ratio of the shaded in blocks to the unshaded blocks in its simplest form.

6.3 What percentage of the rectangle has been shaded in?

Question 7

A garden is 7.5m wide and exactly 5m long.

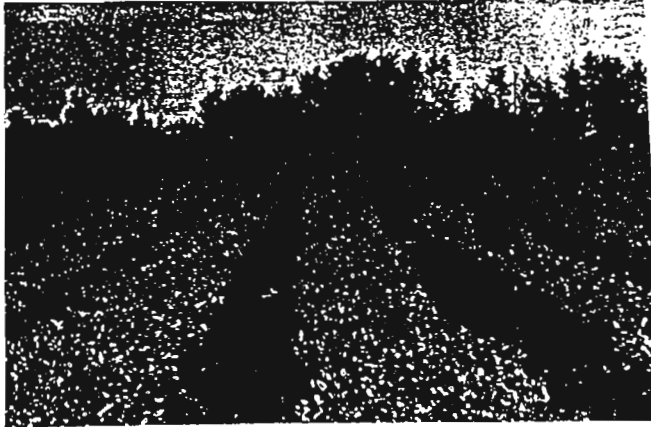

Calculate the area of the garden.

Question 8

Examine the diagram below of a brick.

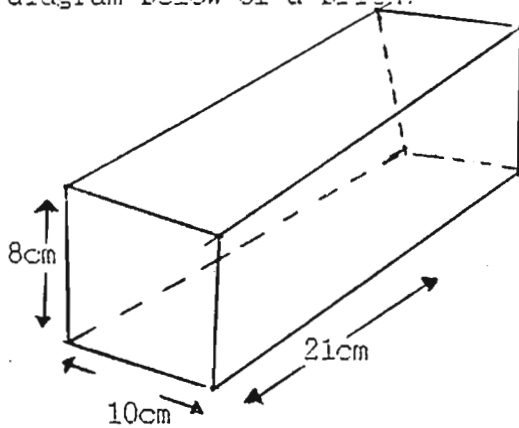

8.1 What is the volume of this brick?

8.2 When Mrs Sithole places the brick on a scale, the scale reads 3Kg. What is the density of the brick in g per cm^3 ? Show your working.

Question 9

In the blood of an adult man there are about 4.5×10^{10} white blood cells and 3×10^{13} red blood cells.

Calculate the total number of blood cells.

Question 10

The SADF launched a rocket from Worlds View. It takes 3.6×10^4 seconds for the rocket to pass Estcourt.

10.1 How many minutes does it take?

10.2 How many hours does it take?

Question 11

Chemists divide substances into elements, compounds and mixtures.

11.1 Which of the following are :

(a) Elements

(b) Compounds

(c) Mixtures ?

Hydrogen ; Air ; Water ; Beer ; Nitrogen ;

Sugar ; Carbon ; Protein ; Starch

11.2 How many hydrogen atoms and oxygen atoms are there in one water molecule?

Question 12

Examine the table below which shows the average mass of rats at different ages.

Age (days)	Mass (g)
0	2.1
1	2.2
2	2.4
10	4.0
16	7.7
22	11.6
28	15.8
34	16.9
40	17.4
46	17.7
52	17.9
58	17.9

12.1 What variables are being measured?

12.2 What is the dependent variable and what is the independent variable?

12.3 Plot the above figures on the graph paper provided.

Question 13

Re-arrange each of the following equations so that the letter in bold is by itself on the left hand side of the equation.

e.g. $2 + x = 4$ will become

$$x = 4 - 2$$

13.1 $108 + x = y$

13.2 $x = \frac{4 + p}{s}$

13.3 Solve the following equation.

$$2m + 9 = 39$$

Question 14

Given that the circumference of a circle is $2\pi r$. What is the value of the earth's circumference if $\pi = \frac{22}{7}$ and the radius = 6370 Km ?

Question 15

Examine the following diagrams .

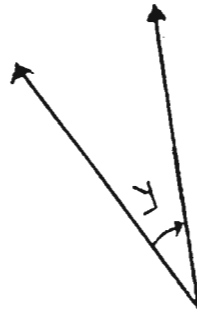
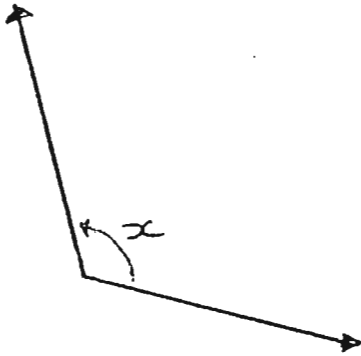

Using your protractor work out what the angles of x and y are.

'INTO SCIENCE' POST-TEST

'INTO SCIENCE' SKILLS - POST TEST

INSTRUCTIONS:

- 1) Answer this test in your answer booklet marked A
- 2) You must answer all the questions.
- 3) You must answer test A before test B. When you have completed test A put your hand in the air. When your time is noted, you may immediately start with test B.

Question 1

Calculate the following.

(a) $16 + (10 \div 5)$

(b) $-8 + -5$

(c) $(-6) \times (-7)$

Question 2

- 2.1 Calculate the following to three decimal places, without using your calculator.

$$6.584 \times 6.354$$

- 2.2 40.0g of fleshy leaves were dried until no moisture remained. The dry mass of the leaves was now 7.6g. Calculate the following to one decimal place.
- (a) What mass of water was there in 40.0g of the leaves?
 - (b) What mass of water would have been in 100g of the leaves?

Question 3

Convert the following into metres, showing your working out.

3.1 64.4 km

3.2 3000 mm

Question 4

The marks (%) for ten pupils who wrote a standard 8 Biology test are as follows:

80, 76, 42, 34, 58
66, 67, 59, 84, 83

Calculate the average mark.

Question 5

5.1 Round off the following figure to one decimal place

9.54

5.2 Express the following to 3 significant figures

2.2356

Question 6

Examine the following rectangle and answer the questions below.

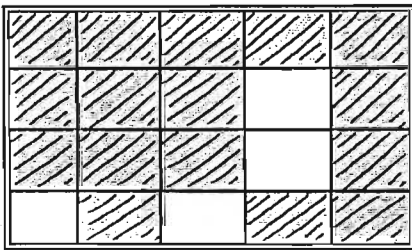

6.1 How many blocks have been shaded in?

6.2 Express the ratio of the shaded in blocks to the unshaded blocks in its simplest form.

6.3 What percentage of the rectangle has been shaded in?

Question 7

A swimming pool is 4.5m wide and exactly 10m long.
Calculate the area of the swimming pool.

Question 8

Examine the diagram below of a brick.

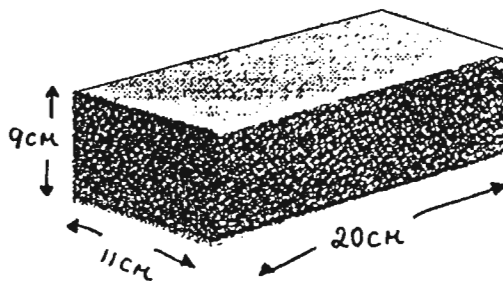

- 8.1 What is the volume of this brick?
- 8.2 When Mrs Gumede places the brick on a scale, the scale reads 4 kg. What is the density of the brick in g per cm^3 ? Show your working.

Question 9

In the blood of an adult horse there are about 6×10^{10} white blood cells and 3.5×10^{13} red blood cells. Calculate the total number of blood cells.

Question 10

The SADF launched a rocket from Worlds View. It takes 4.1×10^4 seconds for the rocket to pass over Durban as it heads out to sea.

- 10.1 How many minutes does it take?
- 10.2 How many hours does it take?

Question 11

Chemists divide substances into elements, compounds and mixtures.

11.1 Which of the following are:

- (a) Elements
- (b) Compounds
- (c) Mixtures ?

Oxygen; air; chlorine; wine; carbon dioxide; salt; fats; calcium; glucose.

11.2 How many carbon atoms and oxygen atoms are there in one carbon dioxide molecule?

Question 12

Examine the table below which shows the average mass of hamsters at different ages.

Age (days)	Mass (g)
0	1.4
2	1.6
4	2.0
8	3.5
14	6.2
20	9.8
26	12.8
32	13.6
38	13.9
44	14.1
50	14.2
56	14.2

12.1 What variables are being measured?

12.2 What is the dependent variable and what is the independent variable?

12.3 Plot the above figures on the graph paper provide.

Question 13

Re-arrange each of the following equations so that the letter in bold is by itself on the left hand side of the equation.

13.3 $64 + \mathbf{x} = y$

13.2 $x = \frac{\mathbf{8} + \mathbf{r} \mathbf{s}}{\mathbf{t}}$

13.3 Solve the following equation.

$$6x + 6 = 42$$

Question 14

Given that the circumference of a circle is $2\pi r$. What is the value of the moons circumference if $\pi = \frac{22}{7}$ and the radius = 630km?

Question 15

Examine the following diagrams.

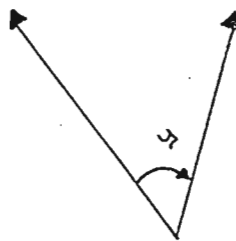
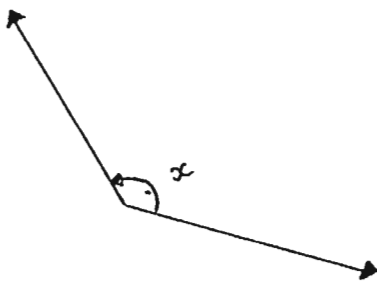

Using your protractor work out what the angles of x and y are.

'APU' PRE-TEST

(1)

INTO SCIENCE

The University of Natal (Pietermaritzburg) is planning to introduce a new F.D.E SCIENCE course for teachers wishing to teach science subjects in secondary school. This course will use distance education materials produced by the United Kingdom Open University.

We are starting to trial the first stage of this course called INTO SCIENCE with interested groups of Colleges of Education students.

We would like to find out how much students' understanding of science improves during this stage. We have therefore put together some sample questions designed to assess students' ability to use scientific thinking-processes.

We would be very grateful if you could help by answering these questions. The assessment will not count towards your college assessment, and what you write will be treated in strict confidence and seen only by members of the research team.

Full name: _____

Year of study at college, and course: _____

Last school attended: _____
(Its name and place, and ex-Department)

In which year did you finish school? _____

Tick the subjects you have done below:

Subject	STD 6	STD 7	STD 8	STD 9	STD 10
General Science					
Physical Science					
Maths					
Biology					
Physiology					

Question 1

Study the diagrams of the woodlice carefully and then suggest one feature which is unique to each animal (i.e. a way in which each of the woodlouse differs from the other three). Ignore any differences in size.

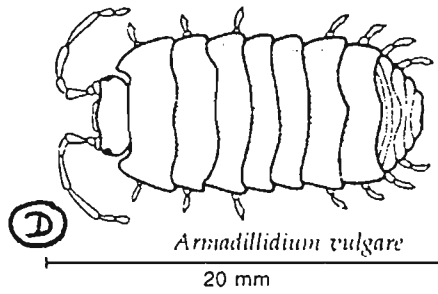
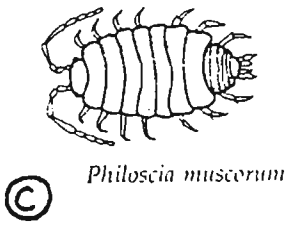
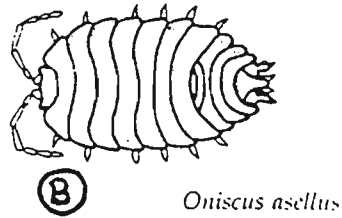
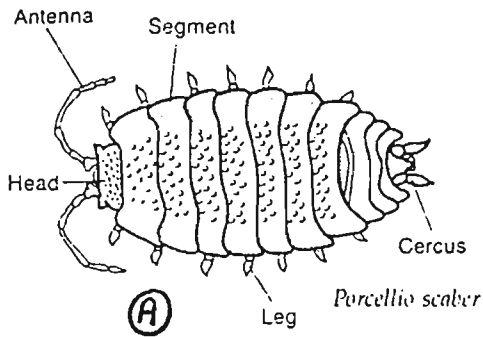

- A: _____

- B: _____

- C: _____

- D: _____

Question 2

To grow butterflies, you need their eggs and their food, and a cage to keep them in. (The food must be fresh).

There is some more information about different kinds of butterflies below.

Butterfly	Food plant	Egg colour	How many days for eggs to hatch	Colour of caterpillar	Colour of Pupa
Small Tortoise-shell	Nettle	Green, then black	5	Black with white flecks	Black, brown or green
Common Blue	Bird's foot, Trefoil	Pearl white	10 -15	Green with brown line	Green
Swallow Tail	Fennel	Yellow, then brown	6	Black with white marks	Green then brown
Painted Lady	Spear Thistle	Pale green	7	Grey-black	Grey or green
Camberwell Beauty	Willow, Sallow	Red-brown	7	Black with red blotches	Brown

Use the table to help you to answer these questions:

a) What is the food plant of the Swallow Tail Butterfly?

b) Which butterfly's eggs take longer to hatch?

c) One butterfly lays red-brown eggs. The colour of its pupa is

Question 3

The chart shows the number of people in different age groups for four different countries:

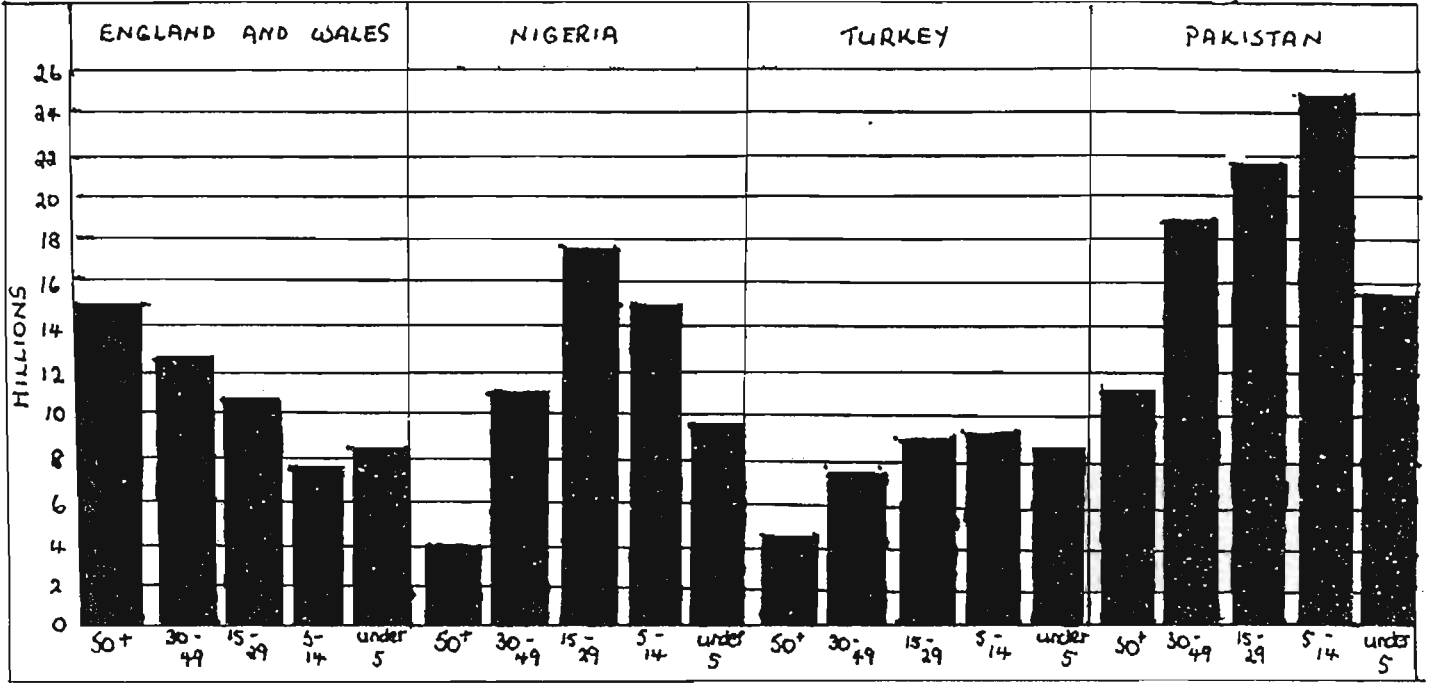

Use the chart to answer the following questions:

a) How many people in England and Wales were over 50 years old when the chart was drawn?

b) Which country has the largest total population?

c) Two countries have a bigger proportion of their population in the 5-14 group than in any other age-range.

Which two countries are they?

Question 4

The diagram below shows leaves taken from plants of the same species. The plants were grown under identical conditions except for light. The amount of light received by each leaf is shown above it.

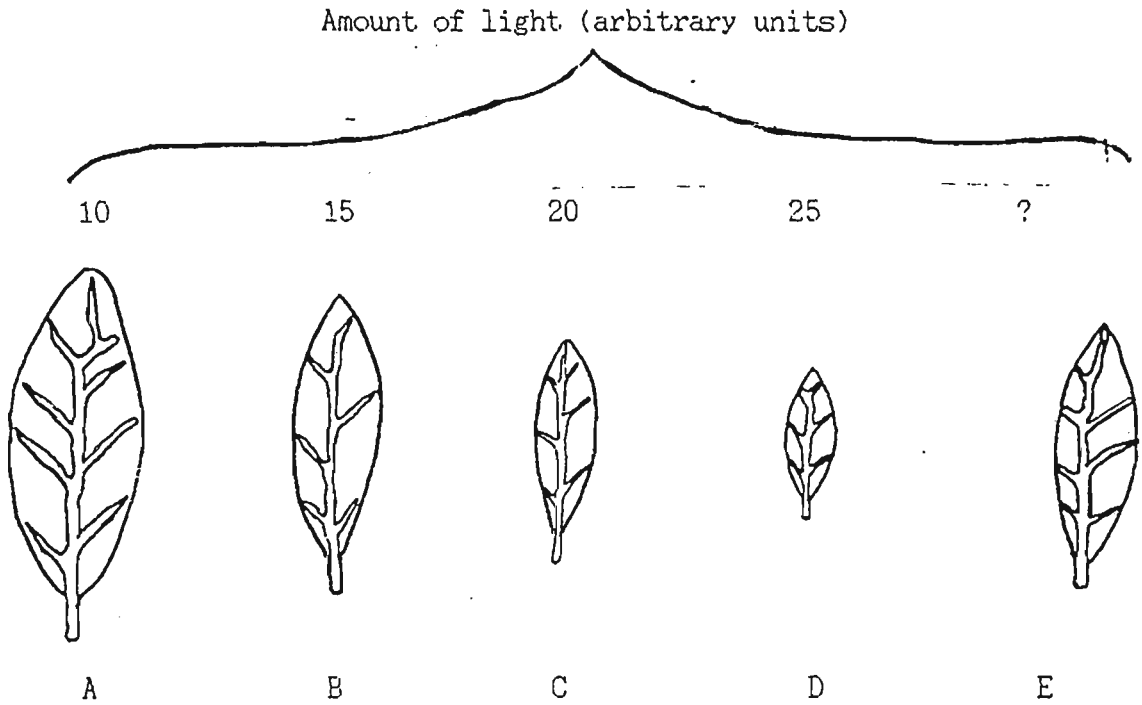

a) Measure the length of each leaf in millimetres and write down the lengths on the spaces provided.

- A _____
- B _____
- C _____
- D _____
- E _____

b) Plot a graph to show the length of each leaf.

c) How much light do you think leaf E received?

Question 5

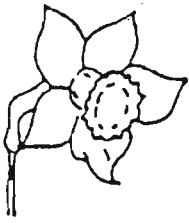

Daffodil



Crocus



Snowdrop

Mr. Brown always planted daffodils, crocuses, and snowdrops at the same time each year. He noticed that the same plants were in flower at different times in different years. He kept a record for 3 years by drawing the different flowers in a table like this:

	Early Jan.	Late Jan.	Early Feb.	Late Feb.	Early March	Late March	Early April	Late April
Year 1								
Year 2								
Year 3								



Mr. Brown has forgotten to put snowdrops on the record for year 3 but one can work it out from the pattern in year 1 and 2.

a) When do you think the snowdrops flowered in year 3?

b) Explain how you worked this out.

Question 6

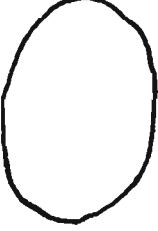
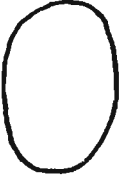
The table shows the eggs of 5 birds (drawn half-size).
Underneath you can see the number of eggs usually laid at one time. The
average number of days to hatch the eggs is also given.

	Golden eagle	Crow	Robin	Blackbird
				
Average number of eggs	2	3	6	5
Average number of days to hatch	40	19	13	14

A magpie's egg
(on the same scale)
is this size



- a) Can you use the information to say how many eggs the magpie is likely to lay?

If so, how many?

- b) Can you use the information to say how long the magpie's eggs are likely to take to hatch?

If so, how long?

Question 7

Four sealed tubes were set up as shown below using water-living plants and animals. The experiment was left for twelve hours.

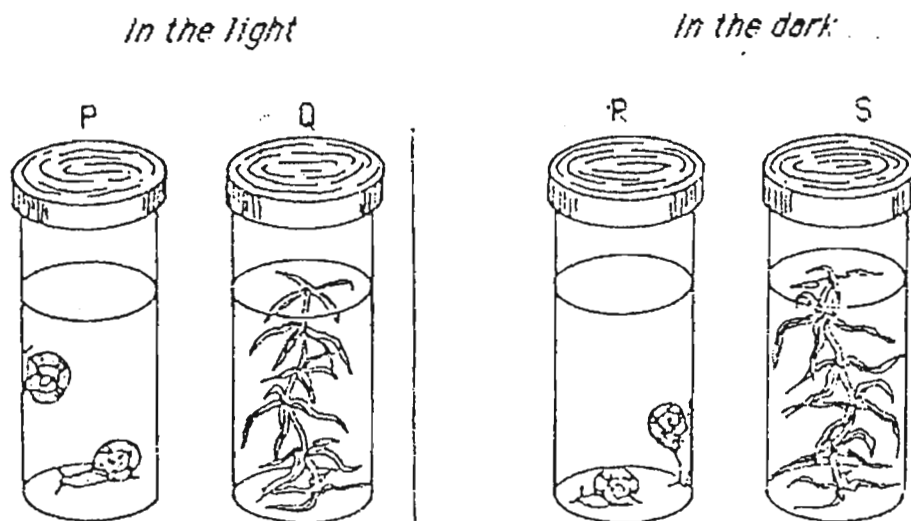

- a) At the end of the experiment which of the following tubes of water would you expect to contain the **least** carbon dioxide?
Tick in the box next to the one you choose.

- A Tube P
- B Tube Q
- C Tube R
- D Tube S
- E All tubes the same

- b) Give the reasons for your choice.

Question 8

When a farmer fed his chickens on a mixture of corn and milled rice (rice on which the husk has been removed), many of his chickens became ill.

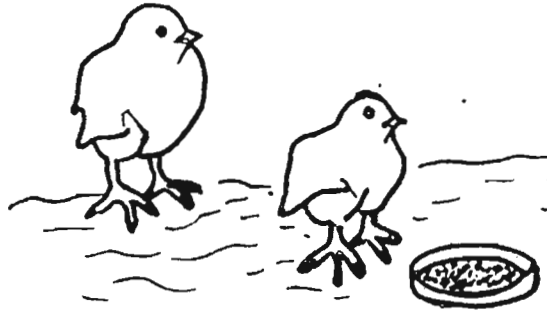

He thought the cause of the illness was the lack of rice husk in the chickens' diet.

To test this, he decided to divide his chickens into two equal groups and give one group one sort of diet and the other a different one.

He was going to compare how well each group were after one week on the diets.

Which pair of diets should he use to test his idea?
Put a tick in the box beside the one you choose.

- | | | |
|--------------------------|------------------------|------------------------|
| <input type="checkbox"/> | Corn and milled rice | Milled rice |
| <input type="checkbox"/> | Corn and milled rice | Unmilled rice |
| <input type="checkbox"/> | Corn and milled rice | Corn and unmilled rice |
| <input type="checkbox"/> | Corn and unmilled rice | Milled rice |

QUESTION 9

A pupil plans to do this experiment with instant coffee powder and instant coffee granules.

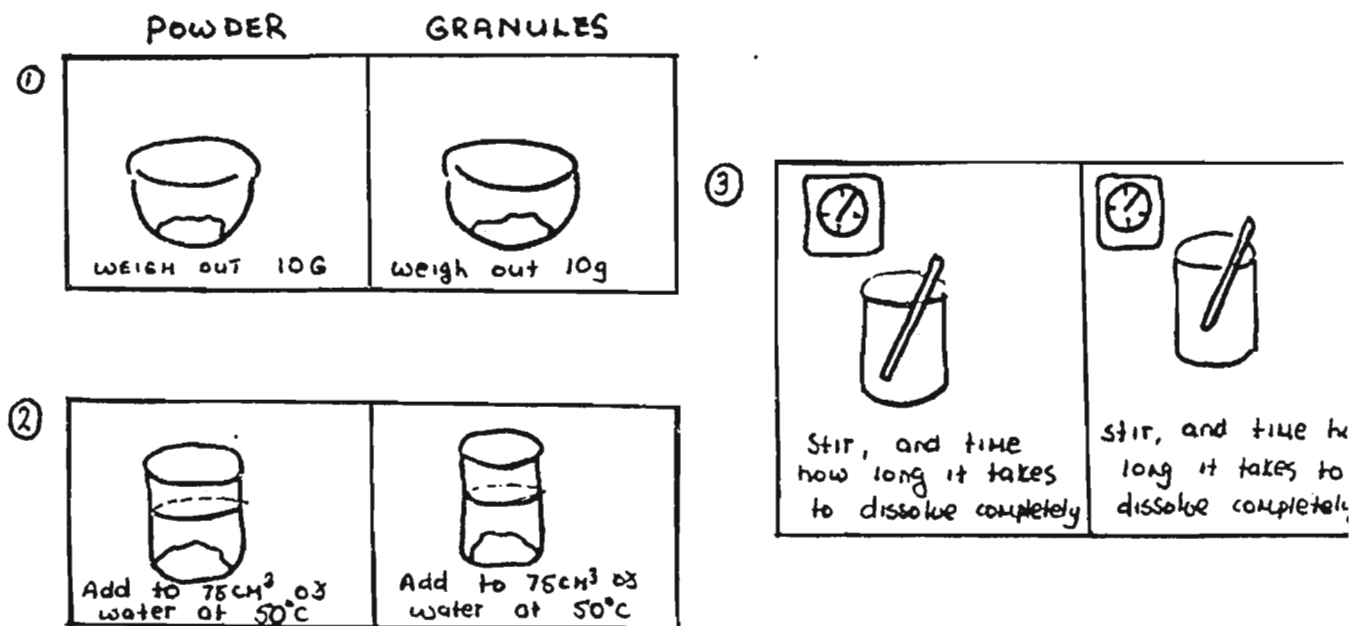

Which of the following is this experiment testing?
Tick one box.

- A. Coffee powder dissolves more quickly in hot water.
- B. Coffee powder dissolves more quickly when you stir it.
- C. Coffee powder dissolves more quickly than coffee granules.
- D. More coffee powder can dissolve than coffee granules.

QUESTION 10

A pupil used this apparatus for experiments with soils.

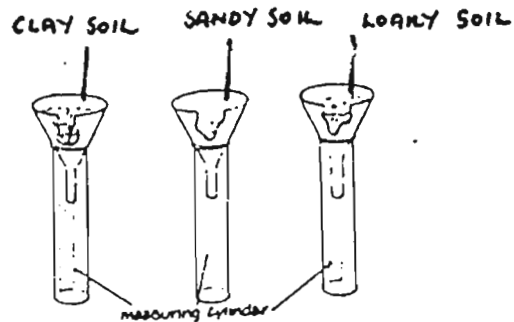

He wanted to find out which kind of soil is best at holding water.

This is what he did:

- Step 1 * He collected three kinds of soil.
- Step 2 * He completely dried all three kinds of soil.
- Step 3 * He put equal volumes (60cm³) of soil into each funnel.
- Step 4 * He carefully poured 200cm³ water on to each soil.
- Step 5 * He timed how long it took for the first drop of water to fall into the measuring cylinder.

One of the steps that he took is not suitable for for this experiment.

Write down which step it is, what he should have done instead, and why.

FINALLY. PLEASE HELP WITH THIS SURVEY.

We would like to find out some information about the home backgrounds of students at this college. Could you please complete the table below. Again all information will be treated as strictly confidential.

Father Mother Guardian
(if applicable)

A. Did he/she attend school? _____

If so, please state the last class attended (e.g. Matric. Standard 4 etc.) _____

B. What is his/her occupation? _____

THANK YOU FOR YOUR INTEREST AND YOUR CO-OPERATION.
WE HOPE THAT YOU ENJOY YOUR STUDIES THIS YEAR AND WE WISH YOU ALL THE BEST.

'APU' POST-TEST

POST TEST II

INSTRUCTIONS:

You have one hour in which to complete this test. All your answers must be written in the spaces provided.

Question One

Study the diagrams of these stonefly nymphs (young insects) which are found clinging to the underside of rocks in streams. Suggest one feature which is unique to each animal (ie. A way in which each of these insects differs from the other three). Ignore any differences in size.

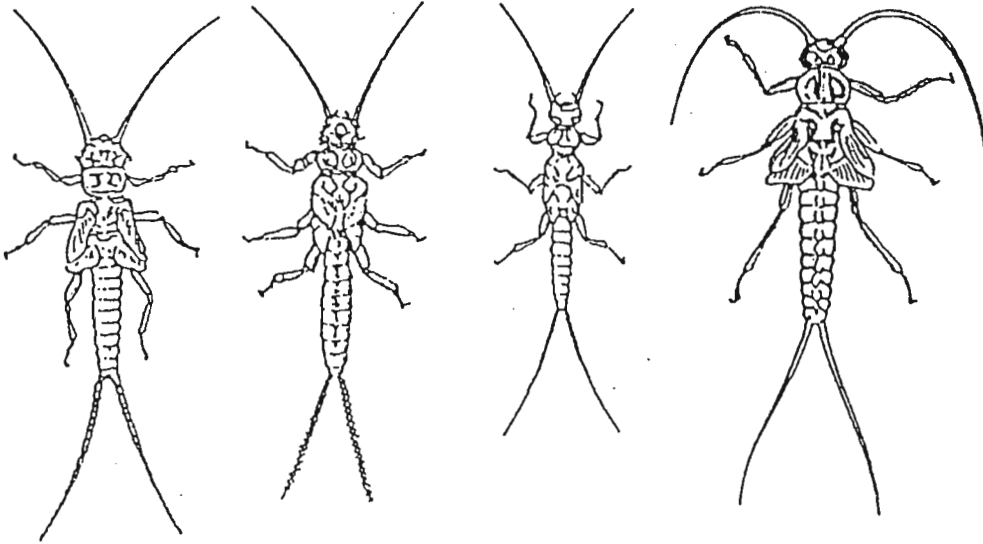

A
X4

B
X4

C
X4

D
X4

A. _____

B. _____

C. _____

D. _____

Question Two

Pollen is one of the causes of hay fever. Every day a newspaper published the number of pollen grains in a sample of air as well as the air temperature and the humidity. This was to help those who suffer from hay fever. The higher the percentage humidity, the damper the air.

Date	Number of pollen grains	Temperature in °C	Humidity %
23 June	25	25	65
16 May	80	26	58
1 June	148	24	49
7 July	170	17	45
23 August	173	22	46
9 July	210	20	42
20 July	258	19	34
2 August	304	25	30

- a) What was the number of pollen grains on the 23rd August? _____
- b) On what date was the temperature the coldest? _____
- c) The number of pollen grains on a particular day was 80. What was the percentage humidity on that particular day? _____
- d) Which one of the variables indicated on the table do you think affects the number of pollen grains? Explain how you arrived at your answer.

Question Three

The chart below shows the number of people in different age groups for four different countries.

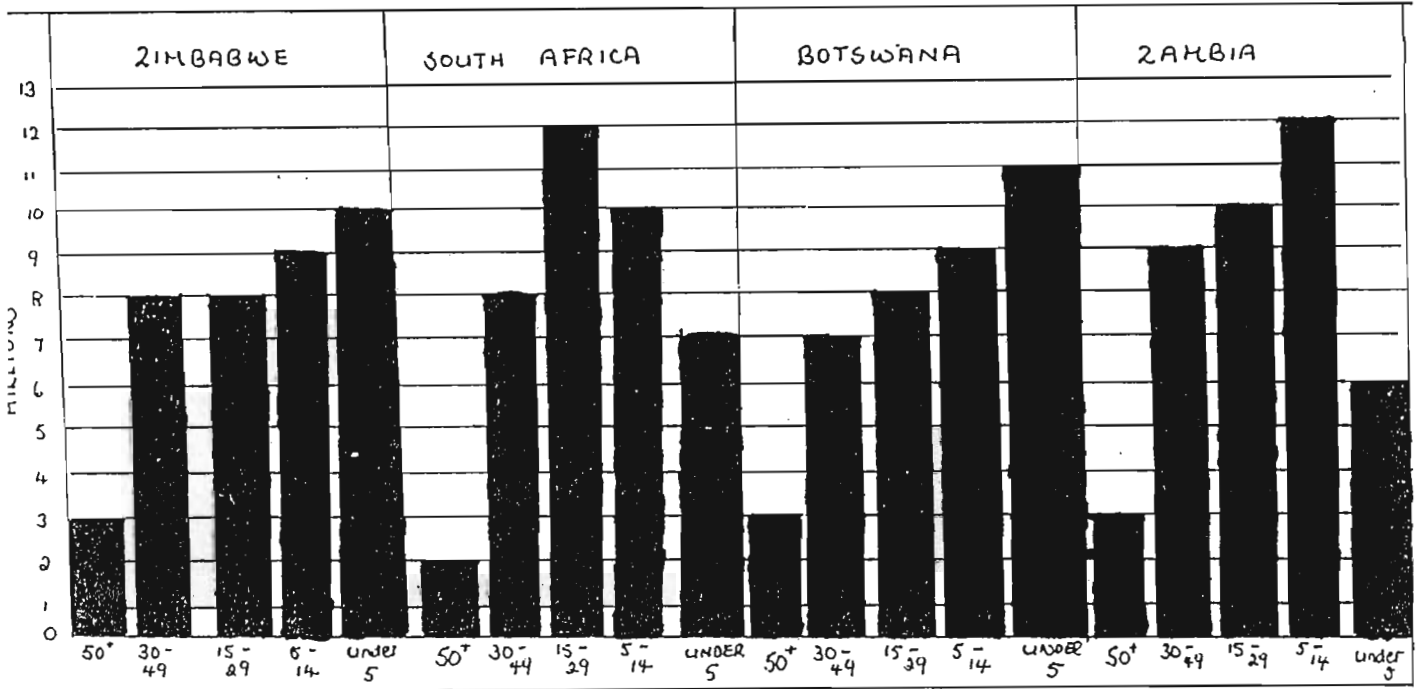

Use the chart to answer the following question.

- How many people in South Africa were between 15-29 years old when the chart was drawn? _____
- Which country has the second largest population? _____
- Two countries have a bigger proportion of their population in the under 5 age group than in any other age-range. Which two countries are they?

- Examine the 5-14 age group for Zambia. What percentage of the total population for all four countries does this age group make up? _____

Question Four

The diagram below shows seedlings which have been germinated under identical conditions, except for light. The seeds were taken from the same plant. The amount of light received by each seed is shown above it.

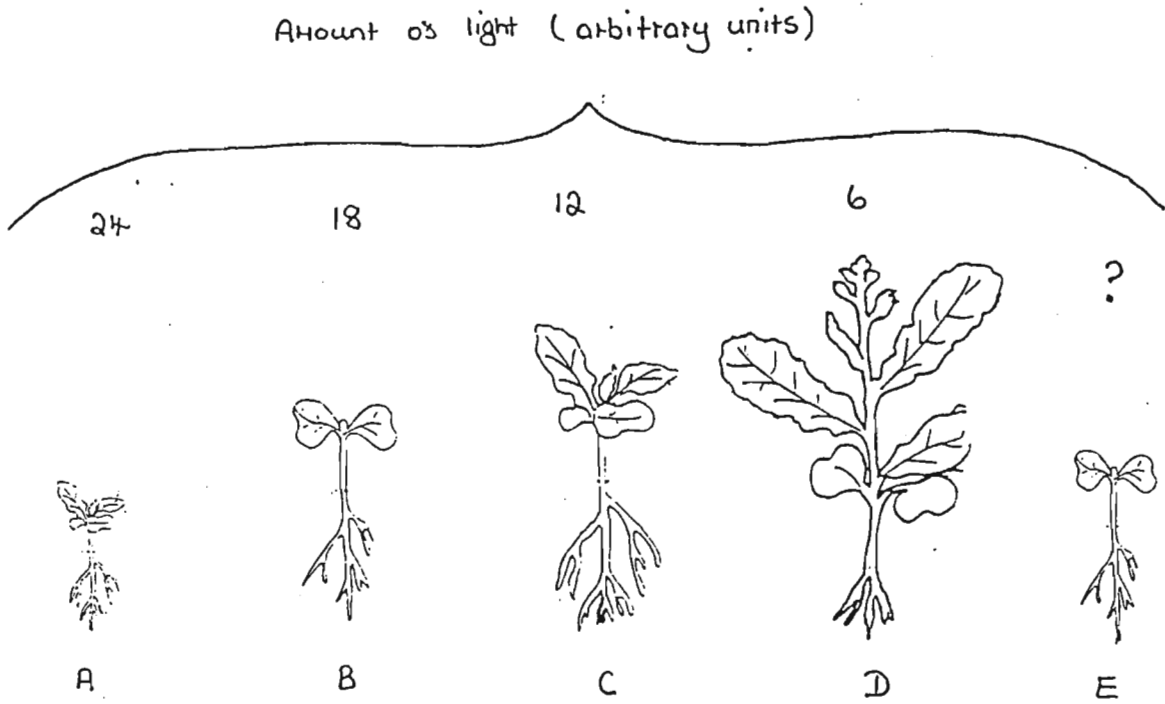

a) Measure the total length of each seedling in millimetres and write down these lengths on the spaces provided.

- A. _____
- B. _____
- C. _____
- D. _____
- E. _____

b) Plot a graph on the paper provided to show the length of each seedling.

c) How much light do you think seedling E received? _____

Question Five



BLUEBELL



SWEET-PEA



FOXGLOVE

Cedric the gardener, always plants bluebells, sweet-peas and foxgloves at the same time each year. He noticed that the same plants were in flower at different times in different years. He kept a record for three years by drawing the different flowers in a table like this.





	Early Jan.	Late Jan.	Early Feb.	Late Feb.	Early March	Late March	Early April	Late April
Year 1								
Year 2								
Year 3								

Cedric has forgotten to put sweet-peas on the record for year 3 but one can work it out from the pattern in year 1 and 2.

- a) When do you think the sweet-peas flowered in year 3? _____
- b) Explain how you worked this out.

Question Six

The table below shows the eggs of 4 birds (drawn half-size). Underneath you can see the number of eggs usually laid at one time. The average number of days to hatch the eggs is also given.

	Canary	Starling	Brown Eagle	Magpie
				
Average number of eggs	7	6	3	4
Average number of days to hatch	14	16	36	20

A Swifts egg (on the same scale) is the following size:



- Can you use the information on the table to predict how many eggs the swift is likely to lay? _____
If so, how many? _____
- Can you use the information on the table to predict how long the Swift's eggs are likely to take to hatch? _____
If so, how long? _____
- In as much detail as possible, describe the relationships which are indicated by the above table. _____

Question Seven

Four sealed tubes, were set up as shown below. The experiment was left for twelve hours.

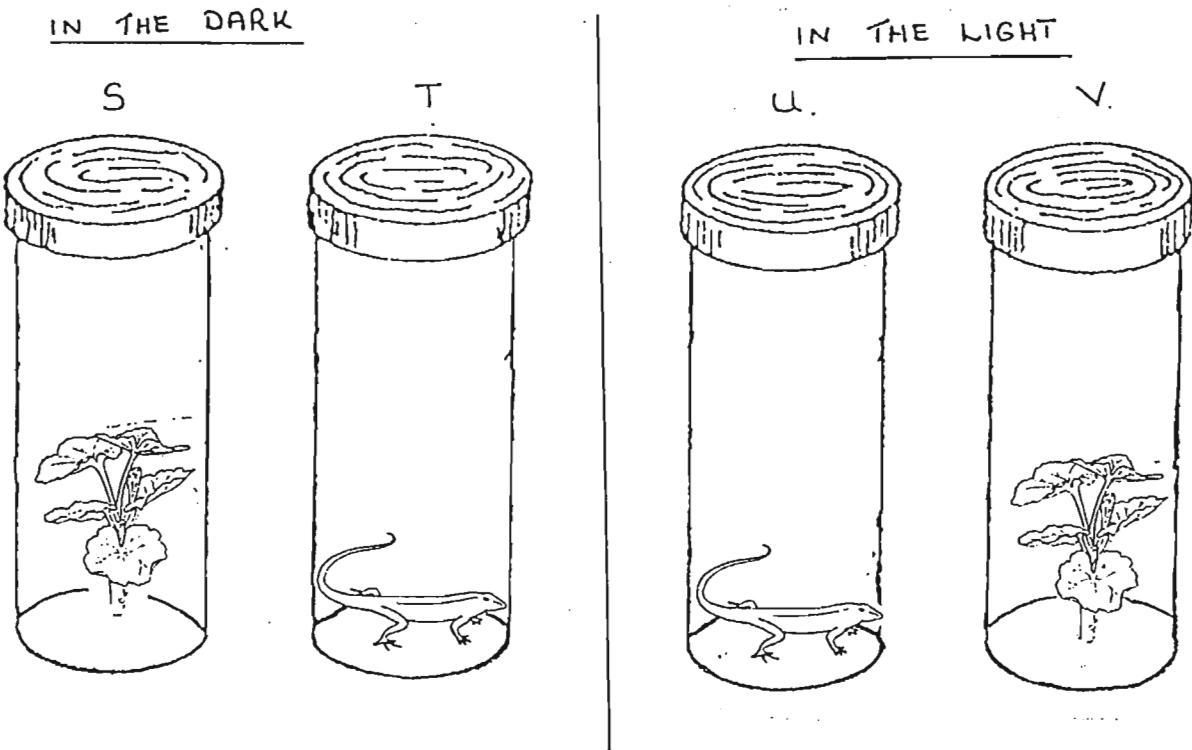

a) At the end of the experiment, which of the following tubes would you expect to contain the least carbon dioxide. Put a tick in the box next to the one you choose.

- A Tube s
- B Tube t
- C Tube u
- D Tube v
- E All tubes the same.

b) Give reasons for your choice.

Question Eight

When a cattle farmer fed his young calves with a mixture of cattle feed and a protein enriched supplement, he found that many of the calves became ill.



The farmer thought that the cause of the illness might be the protein which had been added to the supplement. In order to test this theory he decided to divide his calves into two equal groups and give one group one sort of diet and the other a different one. He would then compare how well each group was after one week on the diets.

a) Which pair of diets should he use to test his idea?
Put a tick in the box next to the one you choose.

- A

Cattle feed and protein enriched supplement.	Supplement with no protein.
----------------------------------------------	-----------------------------
- B

Cattle feed and protein enriched supplement.	Protein enriched supplement.
----------------------------------------------	------------------------------
- C

Cattle feed and supplement with no protein.	Protein enriched supplement.
---------------------------------------------	------------------------------
- D

Cattle feed and protein enriched supplement.	Cattle feed and supplement with no protein.
----------------------------------------------	---------------------------------------------

b) Give the reasons for your choice.

Question Nine

The owner of a dried milk factory is trying to decide if he should concentrate on marketing milk powder or milk granules. He conducts the following experiment in order to help himself make up his mind.

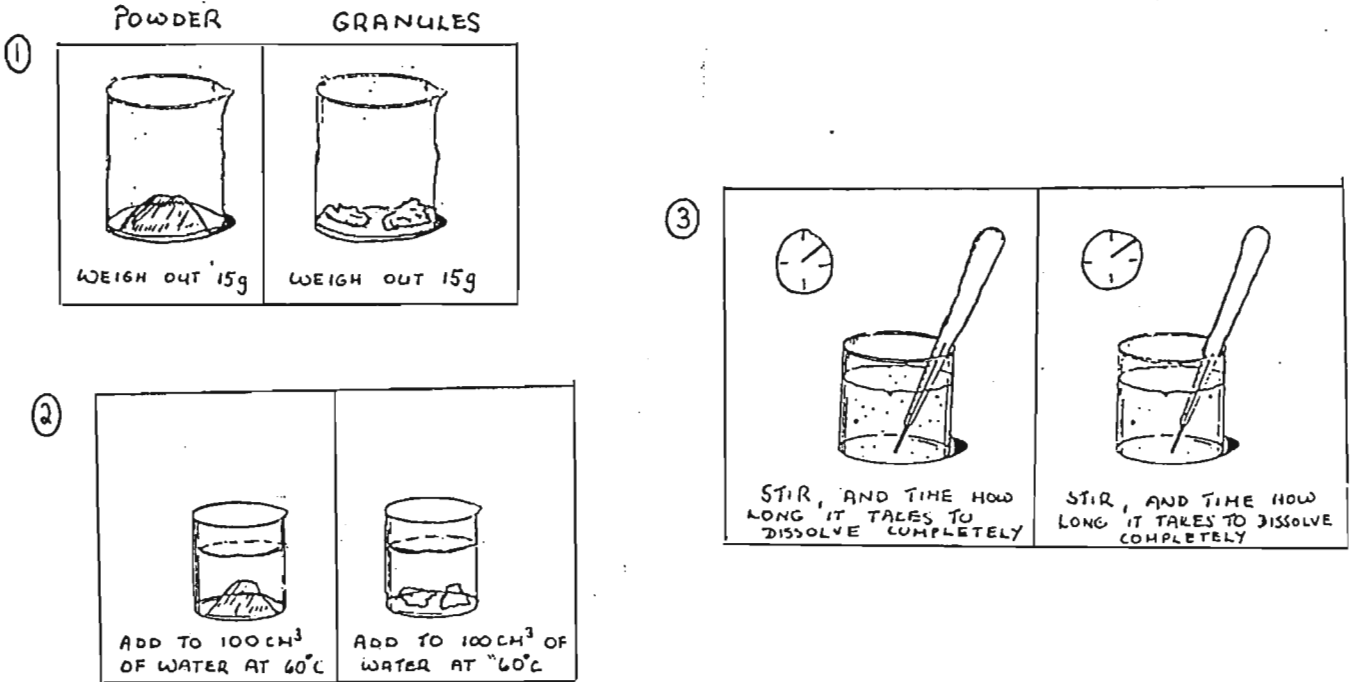

a) Which of the following is this experiment testing?
Put a tick in the box next to the one you choose.

- A. More milk powder can dissolve than milk granules.
- B. Milk powder dissolves more quickly than milk granules.
- C. Milk powder dissolves more quickly when you stir it.
- D. Milk powder dissolves more quickly in hot water.

b) Give the reasons for your choice.

Question Ten

A pupil used this apparatus for experiments with soils.

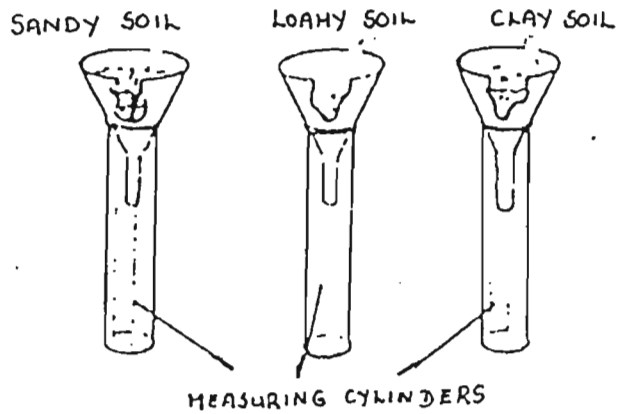

He wanted to find out which kind of soil allows water to pass through the quickest. This is what he did:

- Step 1 * He collected three kinds of soil.
- Step 2 * He completely dried all three kinds of soil.
- Step 3 * He put equal volumes (60cm) of soil into each funnel.
- Step 4 * He carefully poured 200cm water on to each soil.
- Step 5 * He measured the total amount of water that had passed through each soil and collected in the measuring cylinder.

One of the steps that he took is not suitable for this experiment.

Write down which step it is, what he should have done instead and why.
