

**Optimal Energy Control of a Grid Connected Solar-Wind based
Electric Power Plant**

by

Mukwanga Willy Siti

Submitted in fulfilment of the requirements for the degree

DOCTOR of PHILOSOPHY: ELECTRICAL ENGINEERING

in the

SCHOOL OF ENGINEERING

COLLEGE OF AGRICULTURE, ENGINEERING AND SCIENCE

UNIVERSITY OF KWAZULU NATAL

MARCH 2016

Supervisor: Dr REMY TIAKO

**COLLEGE OF AGRICULTURE, ENGINEERING AND SCIENCE
DECLARATION 1 - PLAGIARISM**

I,, declare that

1. The research reported in this thesis, except where otherwise indicated, is my original research.
2. This thesis has not been submitted for any degree or examination at any other university.
3. This thesis does not contain other persons' data, pictures, graphs or other information, unless specifically acknowledged as being sourced from other persons.
4. This thesis does not contain other persons' writing, unless specifically acknowledged as being sourced from other researchers. Where other written sources have been quoted, then:
 - a. Their words have been re-written but the general information attributed to them has been referenced
 - b. Where their exact words have been used, then their writing has been placed in italics and inside quotation marks, and referenced.
5. This thesis does not contain text, graphics or tables copied and pasted from the Internet, unless specifically acknowledged, and the source being detailed in the thesis and in the References sections.

Signed

COLLEGE OF AGRICULTURE, ENGINEERING AND SCIENCE DECLARATION 2 - PUBLICATIONS

DETAILS OF CONTRIBUTION TO PUBLICATIONS that form part and/or include research presented in this thesis (include publications in preparation, submitted, *in press* and published and give details of the contributions of each author to the experimental work and writing of each publication)

- [1] MW Siti and R. Tiako " Optimal Energy Control of a Grid Connected Solar Wind based Electric Power Plant applying the Time of Use Tariffs" International Review of Electrical Engineering (IREE), Vol. 10, No. 5, pp. 653 – 661, October 2015.
- [2] MW Siti and R. Tiako" Optimal Energy Control of a grid connected solar wind with pumped Hydro storage “Under Review in the Journal of Modern Power System and Clean Energy MPCE”, reference manuscript 16 – 00069.
- [3] MW Siti and R. Tiako " Model Predictive Control Strategy for Grid connected Solar wind " Accepted for the 5th IET International conference on renewable Power Generation" 21 - 23 September 2016, IET London: Savoy Place, UK.

Signed:

DEDICATION

To the Lord Jesus Christ, the saviour of my life

ACKNOWLEDGEMENTS

First, I would like to express my sincere gratitude to my advisor, Dr Remy Tiako for his inspiring guidance, encouragement and support. His valuable contributions to my studies are respected and will never be forgotten.

I would like to express my sincere gratitude to the University of KwaZulu-Natal for financial assistance.

ABSTRACT

In the present context of urge energy demand, renewable energy is considered as an alternative source of clean energy. In view of the increase in the price of fossil fuel due to its rarity and emissions, more integration of renewable sources is needed for better economic management of the grid. This research work has been done in two parts. The first part deals with the daily energy consumption variations for the low demand season and high demand season on weekdays and weekends. The intention is to correlate the corresponding fuel cost and estimate the operational efficiency of the hybrid system, which comprises the PV, PW, DG, battery system, for a period of 24 hours taken as control horizon. The latest published research literature has shown that a good deal of work has been done using a fixed load and uniform daily operational cost. The economic dispatch strategy, fuel cost, energy flows and energy sales are analysed in this study. The results show that a renewable energy system, which combines the PV/PW/diesel/battery models, achieves more fuel saving during both the high demand and low demand seasons than a model where the diesel generator satisfies the load on its own. The fuel cost during the low demand and high demand seasons for weekdays and weekends shows considerable fluctuations, which should not be neglected if accurate operational costs are to be obtained. The model shows the achievement of a more practical estimate of fuel costs, which reflects the fluctuation of power consumption behaviour for any given model. In the last part of the thesis model predictive control (MPC) is introduced in the management and control of power flow. The highlight in this thesis is the management of the energy flow from the hydro pump, wind, photovoltaic system and turbine when the system is subject to severe disturbances. The results demonstrated in the thesis prove the advantages of the approach and its robustness against uncertainties and external disturbances. When analysed with the open loop control system, MPC is more robust because of its stability of the system when external disturbances occur in the system. This thesis presents a practical solution to energy sale, control, optimization and management.

TABLE OF CONTENTS

COLLEGE OF AGRICULTURE, ENGINEERING AND SCIENCE	ii
DECLARATION 1 - PLAGIARISM.....	ii
COLLEGE OF AGRICULTURE, ENGINEERING AND SCIENCE	iii
DECLARATION 2 - PUBLICATIONS	iii
DEDICATION	iv
ACKNOWLEDGEMENTS	v
ABSTRACT	vi
TABLE OF CONTENTS.....	vii
LIST OF FIGURES	x
LIST OF TABLES	xi
LIST OF SYMBOLS	xii
GLOSSARY	xiii
CHAPTER 1: INTRODUCTION	1
1.1 RESEARCH BACKGROUND AND JUSTIFICATION	1
1.2 PROBLEM STATEMENT	2
1.2.1 Sub-objective 1	2
1.2.2 Sub-objective 2	3
1.2.3 Sub-objective 3	3
1.2.4 Sub-objective 4	3
1.2.5 Sub-objective 5	3
1.3 METHODOLOGY.....	3
1.4 RESEARCH DELIMITATIONS.....	3
1.5 BENEFITS OF THE PROJECT	4
1.6 ORGANISATION OF DISSERTATION.....	4
CHAPTER 2: LITERATURE REVIEW	5
2.1 INTRODUCTION.....	5
2.2 OBJECTIVE FUNCTION	5
2.3 OPTIMISATION METHODS APPLIED TO RENEWABLE ENERGY	6
2.4 WIND POWER.....	8
2.5 SOLAR ENERGY	11
2.6 HYDRO POWER	13
2.7 HYBRID SYSTEM.....	14
2.8 SUMMARY	17
CHAPTER 3: OPTIMAL ENERGY CONTROL OF A GRID-CONNECTED SOLAR-WIND- BASED ELECTRIC POWER PLANT APPLYING TIME OF USE TARIFFS.....	18
3.1 INTRODUCTION.....	18

3.2 PROPOSED TECHNIQUES	18
3.3 PHOTOVOLTAIC MODEL.....	19
3.4 WIND MODEL.....	20
3.4 DIESEL GENERATOR MODEL.....	21
3.5 BATTERY MODEL	21
3.6 MODEL DESCRIPTION.....	22
3.7 PROPOSED MODEL	22
3.7.1 Objective Function	23
3.7.2 Data Presentation	26
3.7.3 Power Sources.....	26
3.7.4 Grid Power and Local Load	26
3.8 RESULTS AND DISCUSSION	27
3.9 SUMMARY	33
CHAPTER 4: OPTIMAL ENERGY CONTROL OF A GRID-CONNECTED SOLAR-WIND SYSTEM WITH PUMPED HYDRO STORAGE.....	34
4.1 INTRODUCTION.....	34
4.2 PRINCIPLE OF OPERATION.....	34
4.3 DESIGN MODEL.....	35
4.3.1 Pump hydro storage	35
4.3.2 Optimisation.....	36
4.4 APPLICATION OF THE MODEL	38
4.4.1 Model parameters.....	39
4.4.2 Power sources	40
4.4.3 Grid and local load profile	40
4.5 RESULTS AND DISCUSSION	40
4.6 SUMMARY	46
CHAPTER 5: A MODEL PREDICTIVE CONTROL STRATEGY FOR GRID-CONNECTED SOLAR-WIND SYSTEMS WITH PUMPED HYDRO STORAGE	48
5.1 INTRODUCTION.....	48
5.2 PRINCIPLE OF OPERATION.....	48
5.3 SUB-MODELS	49
5.4 OPEN-LOOP CONTROL.....	49
5.5 MODEL PREDICTIVE CONTROL CONFIGURATION.....	50
5.5.1 Discrete linear model of the MPC.....	51
5.5.2 Constraints	54
5.5.3 Implementation of the main algorithm.....	55
5.6 MODEL PARAMETERS	56

5.6.1 Power sources	56
5.6.2 Grid power and local load	56
5.7 RESULTS	57
5.8 SUMMARY	62
CHAPTER 6: OPTIMISATION AND SALE OF ENERGY TO THE GRID WITH SPECIAL EMPHASIS ON FREQUENCY CONTROL	63
6.1 INTRODUCTION.....	63
6.2 MODEL OF NETWORK DYNAMICS	63
6.3 NETWORK UNIT MODEL	64
6.4 OPTIMISATION MODEL	65
6.4.1 Objective function.....	65
6.4.2 Constraints	66
6.4.3 Application of the Model	67
6.5 MODEL PARAMETERS	69
6.5.1 Power sources	69
6.5.2 Grid power and local load	69
6.6 RESULTS	70
6.7 SUMMARY	74
CHAPTER 7: CONCLUSION AND FUTURE RESEARCH.....	75
7.1 CONCLUSION	75
7.2 FUTURE RESEARCH	75
REFERENCES.....	77

LIST OF FIGURES

Figure 3-1: Hybrid power flow	19
Figure 3-2: High demand season – weekday power flow	28
Figure 3-3: Dynamic of the battery	28
Figure 3-4: High demand season – weekend power flow	29
Figure 3-5: Battery state of charge	29
Figure 3-6: Low demand season – weekday power flow	30
Figure 3-7: Charge and discharge of the battery	30
Figure 3-8: Low demand season – weekend day power flow	31
Figure 3-9: Battery state of charge	31
Figure 4-1: A hybrid solar-wind system with pumped storage system	34
Figure 4-2: Low demand season – weekday power flow	41
Figure 4-3: Reservoir dynamic (low demand season - weekday)	42
Figure 4-4: Low demand season – weekend power flow	42
Figure 4-5: Reservoir dynamic (low demand season weekend)	43
Figure 4-6: High demand season – weekday power flow	43
Figure 4-7: Reservoir dynamic (high demand season weekday)	44
Figure 4-8: High demand season – weekend power flow	44
Figure 4-9: Reservoir dynamic (high demand season weekend)	45
Figure 5-1: Schematic layout of the PV-wind-hydro pump	48
Figure 5-2: The MPC structure [225]	51
Figure 5-3: Simulation of open control without disturbances	57
Figure 5-4: Open-loop simulation of the reservoir dynamic without disturbances	58
Figure 5-5: Simulation of closed-loop control without disturbances	58
Figure 5-6: Closed-loop control simulation of the reservoir dynamic without disturbances	59
Figure 5-7: Simulation of open-loop control with disturbances	59
Figure 5-8: Open-loop simulation of the reservoir dynamic with disturbances	60
Figure 5-9: Closed-loop control simulation of the reservoir dynamic with disturbances	60
Figure 5-10: Closed-loop simulation of reservoir dynamic with disturbances	61
Figure 6-1: Low demand season – weekday power flow	70
Figure 6-2: The reservoir dynamic (low demand season weekday)	71
Figure 6-3: The frequency variation in the network	71
Figure 6-4: Low demand season – weekend power flow	72
Figure 6-5: The reservoir dynamic (low demand season weekend)	72
Figure 6-6: Frequency variation in the network	72
Figure 6-7: The graph of daily load cycle: Power flow under normal condition, the x axis is the time in hour the y axis represent the power in kW	74
Figure 6-8: The graph of daily load cycle: Grid connected photovoltaic system, the x axis is the time in hour and the y axis represent the power in kW	74

LIST OF TABLES

Table 3-2: Daily energy sold to the grid (high season demand weekend)	32
Table 3-3: Daily energy sold to the grid (low season demand, weekday)	32
Table 3-4: Daily energy sold to the grid (high season demand, weekend)	32
Table 3-5: Fuel saving cost (in rand, which is the South African currency).....	33
Table 4-1: Sale of energy to the grid during the low demand season	45
Table 4-2: Sale of energy to the grid during the high demand season	46
Table 5-1: Sale of energy to grid.....	61
Table 5-2: Performance of closed-loop control	62

LIST OF SYMBOLS

- a: Fuel cost coefficient
- b: Fuel cost coefficient
- $P_1(k)$: Control variable representing the energy flow from the PV generator to the main bus at any hour (kW)
- $p_2(k)$: Control variable representing the energy flow from the diesel generator to the local load at any hour (kW)
- $p_3(k)$: Control variable representing the energy flow from the wind generator to the main bus at any hour (kW)
- $p_4(k)$: Control variable representing the energy flow from the battery to the main bus at any hour (kW)
- $p_5(k)$: Control variable representing the energy flow from the total hybrid system to the grid as well as to the local load at any hour (kW)
- $p_6(k)$: Control variable representing the energy flow from the hybrid system to the grid at any hour (kW)
- $p_7(k)$: Control variable representing the energy flow from the hybrid system to the local load at any hour (kW)
- $p(k)$: The electricity price at the k^{th} sampling time

GLOSSARY

ABCO:	Artificial bee colony optimisation
ACO:	Ant colony optimisation
ANN:	Artificial neural networks
DE:	Differential evolution
EA:	Evolutionary algorithm
GA:	Genetic algorithm
GRASP:	Greedy randomised adaptive search procedures
GTS:	Genetic Tabu search
HC:	Hill climbing
HBMO:	Honey bee mating optimization
I-GA:	Immune genetic algorithm
ILP:	Integer-linear programming
ILS:	Iterated local search
LP:	Linear programming
LR:	Lagrangian relaxation
MA:	Memetic algorithms
MINLP:	Mixed-integer non-linear programming
MOEA:	Multi-objective evolutionary algorithm
MOGLS:	Multi-objective genetic local search
MOSA:	Multi-objective simulated annealing
MOSATS:	Multi-objective simulated annealing and tabu search
MOTS:	Multi-objective tabu search
M-PAES:	Memetic-PAES; NLP, non-linear programming
NMS:	Nelder–Mead Simplex
NSGA/NSGA-II:	Non-dominated sorting genetic algorithm/-II
PAES:	Pareto archived evolution strategy
PESA/PESA-II:	Pareto envelope-based selection algorithm/-II
PR:	Path relinking
PSA:	Pareto simulated annealing

PSO:	Particle swarm optimisation
QP:	Quadratic programming
SA:	Simulated annealing
SFGA:	Single front genetic algorithm
SPEA/SPEA2:	Strength Pareto evolutionary algorithm/2
SS:	Scatter search
TS:	Tabu search
VNS:	Variable neighbourhood search

CHAPTER 1: INTRODUCTION

1.1 RESEARCH BACKGROUND AND JUSTIFICATION

Technological development and population growth have led to the over-dependence of many countries on fossil fuel energy. However, concerns about global warming, the shortage of conventional energy and decreasing fossil fuel reserves have led many countries to explore the use of renewable energy systems (RESs), which have a reputation for being clean, inexhaustible and environmentally friendly [1-2]. Therefore, RESs have become more advantageous compared to conventional resources, especially in remote areas. Two main reasons for this phenomenon are the rising cost of fuel and the declining cost of renewable energy systems [3]. Although photovoltaic (PV) and wind generation systems are being deployed to provide autonomous power for various off-grid applications, the main strength of the PV system is its modularity, which allows users to match PV system capacity to the situation. Both PV and wind systems are capital cost intensive. Moreover, as the PV system is dependent on the sun, while the wind system is dependent on the wind, their joint output cannot match the required load on a daily basis. This drawback might be considered a disadvantage when using a renewable energy system on its own. In order for a PV or wind system to meet the load demand completely during a 24-hour day, back-up systems such as a diesel generator (DG) and battery system or a storage system are required [5-9]. Solar power, wind generators and battery banks are expected to have a great impact on the fuel consumption of the DG when they are connected, depending on the day, season and load profile. Better solar or wind output will result in reduced fuel consumption, when the DG is used as a back-up supply, as the two main sources will be able to generate enough capacity to meet the load demand and also charge the storage system. In this work, two main storage systems will be considered. The first will be the battery and the second storage system will be the pump hydro storage (PHS) system. Many authors have discussed the battery storage system. The findings culminated in a proposed combined PV-wind generator-diesel-battery system for off-grid applications or connected to a grid, in which the cost of energy is the parameter used to select the optimal solution [4]. The model employed in [5-9] achieves the optimal configuration for PV panels, battery and DG, minimising the total net present cost of the system, which includes all the life cycle costs throughout the useful lifetime of the system. The development of this work has shown that DG output and the minimum state of charge (SOC) of the battery have an impact on the total net present cost and the optimal dispatch strategy. However, the hybrid system developed by combining the PV-wind generator-DG and battery components have shown many advantages compared to stand-alone systems. In [10], the authors proposed an economic and environmental analysis model of the PV/diesel battery system, in which the objective function represented by the fuel cost is calculated over a period of a year and a simple payback is calculated for the PV module. The second storage system is the pump hydro (PHS) system, which has an advantage over the battery because of the environment. In this work, a PHS system is introduced for a hybrid solar/wind system to replace batteries, which are considered to be harmful to the environment because they contain lead and sulphuric acid, as noted in [11]. The first PHS system application was produced in 1980 [12]. Since then many applications have been developed and today 99% of global storage systems are PHS systems [13 - 14]. Most authors' studies on PHS systems have focused on the development of the technologies themselves and on solving the problem of power supply reliability [15-16]. However, some of the studies on PHS systems focused on the development models of the main components of a hybrid wind-solar-pump storage power system, as well as on the economic performance of the PHS system [17-18].

In contrast to the abovementioned work on hybrid systems, the current work focuses on not only the minimisation of fuel and the pump, but also maximisation of the sale of energy to the grid during peak times, thus taking advantage of the price scheme presented as time of use (TOU).

The main purpose of this work is to maximise energy sales to the grid by taking advantage of the TOU electricity tariff while at the same time minimising the fuel cost of the DG. Various system constraints, such as power limitations, SOC of the battery, and so on, will be taken into account. The objective function is multi-objective, where the first term of the objective function relates to the DG fuel cost. Using an economic dispatch equation, the DG is modelled as a controllable variable power source with minimum and maximum power, and the fuel consumption costs are modelled as a non-linear equation function of the generator output power. The second term entails the sale of energy to the grid using the TOU tariff, which also acts as input to the proposed optimal control strategies. The TOU tariff is an important parameter in this proposed model. The maximisation of energy sales will be achieved by selling more energy to the national grid during peak periods when energy costs are higher than during off-peak and standard periods. The two terms combine into one objective function. In addition, simulation results are presented.

1.2 PROBLEM STATEMENT

Electrical energy is one of the important components in the economic development of any country in the world. Since fossil fuel is the main energy source for most energy-generation plants, its negative impact on the environment is taken into serious consideration. There is a need for clean and sustainable sources of energy, such as wind, solar, tidal and small hydro energy, etc. However, the operation of the hybrid system may lead to poor economic performance if optimal management action is not considered. Demand-side management (DSM) based on the TOU tariff (pricing) is being introduced in several countries, such as South Africa, with the aim to influence customers to shift their loads from peak periods to off-peak and standard periods. Both the power utility and customers will benefit from such a scheme. On the one hand, the utility will see its generators not being overloaded by meeting their reserve constraints. On the other hand, customers can adapt their energy consumption based on the TOU tariff by shifting (reducing) their loads during peak period when energy is costly to off-peak and standard periods at a cheaper energy cost.

To improve the system with the renewable energy as a source, the optimisation and the control of the energy using a control variable is used by connecting a hybrid system to the national grid. This application can also benefit from TOU tariff-based DSM, by maximising the sales of hybrid energy to the grid. In the peak period, for instance, when the grid energy cost is highly increased, the renewable energy plant operator can optimally inject more power into the grid to maximise the benefit (sales). However, a second control objective of minimising the fuel cost of a DG incorporated in the hybrid system has to be taken into account. System constraints such as battery SOC, power output (taken as control variable in this work) limits of each power-generating component (PV, wind turbine, DG, etc.), power balance, etc. should be met during the control horizon.

With this in mind, this work focuses on the optimal control of a hybrid power plant connected to the national grid. Two objective functions are developed. These are the sales of energy to the grid that are to be maximised by accounting for TOU tariff, and the DG fuel cost to be minimised. The system constraints as cited above will be taken into consideration.

1.2.1 Sub-objective 1

- Modelling of the operation efficiency optimisation of the hybrid renewable system, taking into account the TOU tariffs.

1.2.2 Sub-objective 2

- Study and choice of suitable optimisation algorithms.

1.2.3 Sub-objective 3

- Development of a mathematical optimisation model according to the algorithm selected.

1.2.4 Sub-objective 4

- Implementation of the selected algorithm in the Matlab environment.

1.2.5 Sub-objective 5

- Using the Matlab environment, determination of the optimal model and maximisation of the sale of energy to the grid; in the first model the DG fuel cost of the hybrid power plant will be minimised.
- Test of the performance of algorithms and validation of the results.

1.3 METHODOLOGY

The methodology used in this work is to inject the energy produced by the renewable source into the normal grid, especially during the peak period when the demand of the load is increasing. In the first scenario the model is to maximise the sales of energy to the grid and minimise the DG fuel cost of a hybrid power plant based on PV, wind turbines, DG and a battery bank storage system by incorporating the TOU tariff as an input to the model. Constraints such as battery SOC, the power output (taken as control variable in this work) limits of each power-generating component (PV, wind turbine, DG, etc.), power balance, etc. should be met during the control horizon. In the second scenario the storage system will be changed to the PHS system with the same aim, to maximise the sale of energy during the peak period, and in the third scenario the PHS system will be kept as a storage system, the emphasis will be on closed-loop control to shown the robustness of the system in the time when the renewable energy source is unable to meet the load demand. The renewable energy source depends on the weather conditions; it can be the PV or the wind generation system; to keep the system in a stable condition, model predictive control (MPC) is considered. The fourth and last scenario in this work is consideration of the network dynamic in the time the renewable energy source is connected to the grid; the electrical output power can increase or the decrease, which can provoke electro-mechanical unbalance in the generator. In this case instantaneous power reserves refer to the physical stabilising effect of all connected synchronous generators, which can be affected. In each model, the objective functions are derived with the aim to maximise the sale of energy, taking into consideration different constraints on the flow of the energy into the grid as well as to the local load. The models have been applied using `fmincon`, a function included in MATLAB's Optimisation Toolbox, because of the non-linearity of the system.

1.4 RESEARCH DELIMITATIONS

The research is limited only on the simulation

1.5 BENEFITS OF THE PROJECT

- Achievement of a renewable energy system that is operationally cost-effective.
- Reliability of the network (meeting system constraints).
- Reduction of dependence on fossil fuel.
- Reduction of greenhouse gas emission.

1.6 ORGANISATION OF DISSERTATION

Chapter one introduces this dissertation. It discusses the motivation, background, and objectives of the study and the methodology used, as well as the scope of the research.

Chapter two presents the literature review, entailing a theoretical study of the objective function and optimisation methods applied to renewable energy,

Chapter three presents PV, PW, battery and DG models where the models are developed with a multi-objective function.

Chapter four presents a PV, PW and hydro pump as storage system to replace the battery; a model is developed with sale of energy into the system as an objective function.

Chapter five presents a PV, PW, and hydro pump solution offering two models; the first model is used with the application of an open loop and the second with a closed loop control

Chapter six presents a PV, PW, and hydro pump model developed with special emphasis on the stage where the renewable energy is connected to the network to analyse the network dynamics.

CHAPTER 2: LITERATURE REVIEW

2.1 INTRODUCTION

There is a development in the global economy, and the energy sector requirements have also increased. Fossil fuel as a source of energy is becoming scarce. In addition, the carbon emissions, has stimulated interest in energy efficiency and environmental protection [19]. Many studies have determined the need to reduce dependence on fossil fuel by reducing energy consumption in applications to save energy. This may affect domestic, commercial and industrial loads. Many applications have succeeded in achieving energy efficiency based on a reduction in the energy demand or shifting the load to different times of the day [20-21].

Energy efficiency can also be achieved by using renewable sources, such as PV, PW and the storage system [22]. If one takes into consideration the intermittency of the renewable energy technologies compared to traditional energy sources, it can be seen that the renewable energy sources are less competitive and their cost of installation and maintenance is high. However, renewable energy sources also have many advantages compared to traditional sources, such as a reduction in carbon emissions, a reduction in the running cost of the renewable energy plant and a reduction in dependence on fossil fuel resources. Moreover, it can be used in areas where it is difficult to have a grid-connected system and is safer than for example an atomic plant [23].

The selection of the location of renewable energy sources and their configuration are also matters of concern many authors have discussed [24]. They compare the different sources of renewable energy, such as wind power and hydropower, as well as PV and geothermal generation, and take into account the price of the generated electricity, and the implementation to have a better renewable energy system. All the requirements mentioned in [25] have an impact on the decision-making process on the implementation of renewable energy sources. Research has established that wind power has the lowest relative greenhouse gas emissions, the lowest water consumption demands and the most favourable social impact. The disadvantages of the wind system are the size of the land required, the implementation cost, the dependency on wind and the noise. In [26] the authors discussed the strategies for sustainable development of renewable energy, considering energy savings, energy efficiency and the replacement of fossil fuels with various sources of renewable energy.

2.2 OBJECTIVE FUNCTION

Optimisation can be defined in mathematics as the method to find the inputs of a function that minimise or maximise its own value, which must be subject to certain constraints [27]. The objective function can be a single or multi-objective, where the multi-objective function can be described as combinatorial optimisation [28]. To achieve the result of the application on the optimisation, the model or algorithm must be develop, tested and implemented; the entire process can be referred to as computational optimisation. Because of new technological development in algorithms and computer hardware, great progress has been made in recent years with solving complex problems that were more difficult to solve in the past.

The application of optimisation does not mean having the optimum solution to a problem; in the last decade many authors have proposed different approaches, such as the genetic algorithm (GA), particle swarm optimisation algorithm (PSO), heuristic method and artificial neural networks (ANN) to apply to the optimisation problem instead of using a traditional method such as the Newton-Raphson method (NR), linear programming (LP), Lagrangian relaxation (LR) or quadratic programming, etc. Most of the time the heuristic methods can be seen as simplifying procedures that provide a satisfactory, but not necessarily optimal, solution to a large number of

complex problems rapidly [29]. Meta-heuristics are generalisations of heuristics in the sense that they can be applied to a wide set of problems, needing few modifications to adapt to a specific case [30]. Sometimes, when the problem is more complex to solve, the meta-heuristic or the heuristic methods are unable to obtain an accurate solution in the expected time. To solve the problem in the expected time, parallel processing becomes an easy way to obtain a better result in reducing runtimes [31].

The better method to classify meta-heuristic models is based on trajectory methods versus population-based methods. Other possible classifications are memory-based versus less methods, nature-inspired versus non-nature-inspired ones, etc. [32].

- The trajectory meta-heuristics solve has a single solution during the search process, namely single optimisation. They are also solved as a simple iteration improvement process that incorporates the techniques that enable the model to escape from local optima. The trajectory-based meta-heuristics include hill climbing, simulated annealing (SA), tabu search (TS), greedy randomised adaptive search procedures (GRASP), variable neighbourhood search (VNS) and iterated local search [33-34].
- Population-based meta-heuristics apply certain population finding solutions that solve a given number of iterations, also returning a population of solution when the stop condition is achieved. The main population-based meta-heuristics are GA and evolutionary algorithm (EA), scatter search, path relinking, memetic algorithms (MA), and PSO [33-34].

In an optimisation model, there are single objective functions that are solved, taking into consideration their constraints. On the other hand, some applications will require a multi-objective function to be solved. Multi-objective functions are usually divided into two main categories: aggregate weight functions and Pareto-based optimisation models. Aggregating functions entail combinatorial objective functions that combine the objectives to optimise in one mathematical equation. Despite mathematical simplification of the models, they have several drawbacks, such as adjustment of the weights of the objective function to be optimised, especially when they have different scales. Furthermore, this approach gives a single solution as a result of the search process, which becomes a factor limitation in the decision-making process [35].

In [36] the drawbacks of the aggregate function have been solved by the Pareto-based multi-objective optimisation, which establishes the relationships among solutions according to the Pareto-dominance concept.

In recent decades many researchers have discussed the different models of the multi-objective meta-heuristic, which can be included in the categories of the trajectory methods and population-based methods. Trajectory methods include the Pareto archived evolution strategy (PAES), multi-objective simulated annealing, etc. Population-based meta-heuristics include the multi-objective Tabu research (MOTS) and non-dominated sorting genetic algorithm (SPEA). Some authors have extended their research to the combined approach known as the hybrid model that can put together two or more models to get a solution, for example genetic Tabu search (GTS), and multi-objective genetic local search, etc. [37-38].

2.3 OPTIMISATION METHODS APPLIED TO RENEWABLE ENERGY

In response to the worldwide increase in the demand for energy and the growth in population, many researchers focus on the need for a reliable network. Different solutions have been presented, such as increasing the voltage by using a capacitor, frequency control, load shedding, power losses into the network and renewable energy as one of the solutions to alleviate the shortage of energy in the world.

When renewable energy is taken as a solution to the worldwide energy demand, parameters such as cost, design and planning will help in the selection of the best alternative among the different renewable energy systems. The planning stage is important. This entails justifying the allocation patterns of energy resources and services, formulation of policies regarding energy consumption, development of the economy and the structure of the energy system, reliability and energy supply security. Many authors have proposed a solution in this complex model by applying interval linear programming (ILP), chance constrained programming and mixed integer linear programming (MILP) techniques to find solutions that can provide the desired energy resource allocation and capacity expansion plans with a minimised energy security [39].

In [40] the authors discuss a long-term dynamic multi-objective planning model for the extension of the distribution network, along with distributed energy options which, using an immune GA-based algorithm, optimises costs and emissions by determining the optimal model of sizing, placement and dynamics of investments on distributed generation units and network reinforcements over the planning period. In [41] the authors discuss the use of fuzzy-based multi-criteria decision-making procedures in order to determine the most appropriate renewable energy alternative. In [42] the authors re-examine the main computer tools for checking the integration of renewable energy into various energy systems with different objectives. Some authors have compared the performance of mixed integer programming (MIP), GA, SA and TS for solving the problem of minimum cost expansion of power transmission networks under carbon emission programmes [43-46]. In [47] the authors compare the competitiveness of the renewable energy and the different locations that can be used. They propose an optimisation model for optimal planning schemes by considering several renewable technologies: PV, wind turbine, fuel cell and micro-turbine. Cai et al. [48] investigated an optimisation model that integrates ILP, two-stage programming and superiority-based fuzzy-stochastic programming for long-term renewable energy management planning with the objective of generating decision alternatives and helping decision makers to implement the desired policies under various economic and system reliability constraints. In [47] the authors analyse renewable energy according to different sustainability criteria. A PSO model is applied to determine the annual peak load forecasting in an electrical power system with the objective of optimising the error associated with the estimated model parameters [48]. In [49] the authors analyse an LP optimisation model, which consists of the power flow optimisation algorithm for the evaluation of the contribution of the distributed generation production and energy efficiency actions, taking into account the exploitation of the utility sources, power and heat generation, emissions and end use sectors. In [50] the authors take into consideration the establishment of designing heuristic optimisation methods for a cost-effective energy conversion system.

In [51- 52] the authors state that multiple uncertainties necessitate the use of new optimisation models for short-term energy planning. In a large system using a renewable energy source, it is fundamental that the electric system must have an appropriate control system or model to compensate for the variable availability of wind, solar and hydro power. Many algorithms have been applied to find a better solution for energy application, which deals with optimisation techniques, such as prediction of energy demands using fuzzy logic and ANN [53]. In [54] the authors take into consideration the application on a simulator of a renewable energy system when it is connected to the grid and in a stand-alone system. Components considered are wind, solar, energy storage and stand-by plants. A simulator is able to determine the energy flow and optimise the planning of the stand-by plant or grid-connected system. Others publications have discussed the development of pre-processing models and heuristic algorithms for real problems in time and labour planning. The researchers have obtained excellent results [55]. Planning for energy production is a complex problem involving multiple decision-makers and criteria. The authors in [56-57] discussed the criteria for decision-making about a renewable energy source. In Rodriguez et al. [58] reviewed the multi-objective function regarding distributed energy resources planning

and found that DSM and load management will play an important role in future with growing economic implications, necessitating research on renewable energy sources.

Energy has to be produced, transmitted and distributed, so to have a better supply of energy, control of the system or network is a key element to ensure that the electricity supply and demand are always evenly balanced. The authors in [59] applied several optimisation methods to solve the problem of penetration and congestion management of renewable energy sources. In Sood et al. [60] analysed an optimal mathematical model of congestion management for the regulated power sector that dispatches the pool in combination with privately negotiated bilateral and multilateral contracts while optimising social benefit. In [61] Nicknam and Firouzi presented a combinatorial algorithm that contains the Nelder–Mead Simplex (NMS) and PSO, whose results outperformed those obtained by other population-based algorithms such as ANN, ant colony optimisation (ACO) and GA. The integration of the different renewable energy sources is a complex task. In [62] Ostergaard analysed several energy criteria for an energy system model with the objective of determining the way to use heat pumps for the integration of wind power. In [63] the authors presented a mathematical model based on fuzzy adaptive PSO to determine the optimal operational management of distribution networks, including fuel cell power plants, which obtain better results in analysis with GA, PSO, DE, ACO and TS. In order to have reliable renewable energy systems, many researchers have investigated different applications to store energy efficiently, which is an important topic whose solution would effectively disassociate the timing of supply and delivery. In [64] Yongping et al presented a combinatorial objective function to optimise economic load dispatch into the power system, including renewable energy, which uses a back-up system such as a generator or others storage technologies.

The application of renewable energy sources has many advantages; for example in remote areas where conventional energy cannot be implemented, it can be also used to pump water [65, 66]. Some authors have presented the use of PV energy to pump water for irrigation, or it can be applied as a hydro pump that is used as a storage system [67]. Water supply systems [67- 68] are frequently characterised by high energy consumption, which makes them expensive to run. The energy demand determines the cost of the energy. Other factors that contribute to the cost of the energy are the weather, the time of use and reliability of the networks and the cost the utility will link to the energy tariff design. In [69] Vieira and Ramos presented an optimisation model of planning for wind-hydro hybrid water supply systems. There has been considerable interest in the optimal sizing of the design for renewable energy-based greenhouses.

2.4 WIND POWER

Wind is one of the better sources of renewable energy. Recently many researchers have been interested in the design, control and operation of different wind farms because wind is becoming one of the most promising sources of alternate energy. The advantages found by many researchers in the wind field can be confirmed by the increase in turbines of different sizes and the decrease in price per installed production capacity of electricity [70]. Different locations and potentialities have been analysed in recent years to demonstrate the effectiveness of wind technologies around the world [71]. Interesting developments in wind technologies have resulted in growth in offshore development, the implementation of technologies in small-scale grid-connected turbines or stand-alone systems. These developments have an impact on the locations as well as on the technologies themselves.

Many researchers are interested in the development of better strategies to obtain an optimal design and its operation in wind energy systems [72]. However, because of weather conditions, wind technology is not technically viable in all locations in view of wind speed and one has to take into consideration that it is more unpredictable than a solar system. The best areas to implement wind

systems are offshore and high-altitude locations where the wind is stronger and more constant. The factors that determine the potential of wind energy systems are accurate estimation of wind speed distribution, the site selection of wind farms, the operational scheme of wind farms and the operational management of wind power conversion systems. However, before taking an investment decision based on the generation capacity of a wind park, it is important to conduct an accurate survey to have as much data as possible available for the development of the new project.

Some authors have used historical wind velocity data as their references to determine the flow of the wind available at a given site to decide whether it can meet the expected target on load demand [73]. The Bayesian model to calculate long-term wind speed distributions has been presented by Li et al [74]. In [75] Zhao et al presented a GA model where the main components of a wind farm and key technical specifications are taken as the input variable and the electrical system design of the wind farm is a multi-objective function to optimise in terms of both production cost and system reliability.

Other topics researchers in wind power fields have considered are optimisation of the design of wind turbines and wind farm configurations.

The output power of a turbine is determined as a function of the density of the air, the area swept by the turbine blades and the cube of the wind speed. The power quality of wind energy sources needs to be improved. In this regard, some researchers are concentrating on turbine settings in order to achieve optimal performance. Different methods are applied to estimate the power quality of a wind turbine; these include having a good power factor, reactive power compensation for loss reduction, harmonic distortion, etc.

The size of the turbine is an interesting factor in increasing the output of a wind farm. This includes the gearless design discussed by reference [76] for stable wind sources. In [77] the authors presented a multi-objective function for the optimisation of the geometrical parameters of the rotor configuration of stall-regulated horizontal-axis wind turbines with the objective of finding a better trade-off performance between the total energy production per square metre of a wind park and the cost. Maalawi et al [78] presented an optimisation model for the structure of the blade design where the control variable of the model is selected to be the cross-sectional area, radius of gyration and length of each segment and the model uses the frequency as the state variable. Other researchers [79] simplified the structure model of the wind turbine by the removal of any active electronic part (power and control) and then constructing a low-cost fully passive structure. In [80] Lund et al presented the optimal design of laminated composite shell structures, especially in the wind turbine blade, which was proposed by reference [81]. Jensen et al presented the review application to the optimal design of a wind turbine [82]. Li et al analysed the optimisation tools for the range of gearbox ratios and power ratings of multi-hybrid permanent-magnet wind generator systems by using a GA [83]. Kusiak et al [84] presented a multi-objective function; the first part of the objective was the maximisation of the wind output power, while the second part of the equation was to minimise the vibration of the drive train and of the tower.

The authors in [85] presented a new algorithm for the optimisation of the sizing of the rotor and other components of a stand-alone wind battery system. In [86] the authors presented an objective function with the aim to optimise wind turbine blades, where control variables were chord, twist and relative thickness. The second objective was the minimisation of the cost of the energy, which was calculated from the annual energy production and the cost of the rotor. Fuglsang and Thomsen [87] presented a numerical optimisation model together with an aero-elastic load prediction code and a cost model for the site-specific design of wind turbines with the aim to minimise the cost of energy.

A model presented by Fuglsang et al in [88] is intended to minimise the cost of energy where the numerical optimisation and aero-elastic calculation are presented as a combinatorial objective function. In [89 - 90] Kusiak and Zheng presented an optimisation technique where the objective function is the output power produced by wind turbines by combining data mining and

evolutionary computation. Other researchers have compared different methods, such as mixed integer nonlinear programming, to find the optimal capacity, taking into consideration uncertainties arising from wind speed distribution and power speed characteristics [91]. To optimise wind potential, the design and stability of the turbine is important to extract the maximum amount of energy from the wind. The detection and clearance of faults in the electrical network are important factors to have a reliable network. Hameed in [92] offers a review of the techniques, methodologies and optimisation models developed to monitor the performance of wind turbines and perform better detection to avoid the shutdown of the system.

In the last decade wind technology has improved; however, electricity cannot be generated at the wind speed level, so there are some limits related to cut in and cut out data. In wind technologies, the output of the wind is determined by the speed of the wind. In relation to wind prediction, some researchers have presented fuzzy logic modelling for wind turbine power curve estimation [93]. In [94] Shimizu et al presented a multi-objective function to optimise the power and efficiency of flapping wind power generation.

On the other hand, the wind farm configuration determines the optimal positions of turbines to maximise energy production [95]. In [96] the authors presented a GA with an objective function of wind turbine placement, taking the number of wind turbines installed and acreage of land occupied by each wind farm as constraints to the model. In [97] Emami et al presented the work discussed by reference [96], with the inclusion of the new code and solved by the GA, which had better performance than the previously presented model in terms of control of the cost, power and efficiency of the wind farm. In [98] Serrano et al implemented an EA for the optimisation of wind farm configuration problems, which was driven by an integral wind farm cost model based on the cumulative net cash flow value throughout the wind farm's lifespan. Kusiak and Song in [99] present a multi-objective evolutionary algorithm (MOEA); the first part of the equation maximises the wind energy capture, taking into consideration an index that determines constraint violations. In [100] the authors compare the advantages and disadvantages of a wind farm starting with its performance, its failure and the reliability of the wind farm, applying Pareto-based analysis. Mustakerov and Borissova in [101] presented an optimal model to determine the optimal type, number and placement of wind turbines, considering the given wind conditions and wind park area.

One of the main problems related to wind generation is forecasting the output, because of uncertainties. These uncertainties pose a challenge, since computing optimally requires a day-ahead unit commitment process. In [102] the authors solved the problem by using fuzzy optimisation techniques with a multi-objective function by minimising the risks, considering forecast uncertainties. Kusiak et al [103] presented a prediction model of the wind speed in a selected area based on the data receive from its neighbour. In [104] the authors presented a method to forecast wind speed by applying adductive networks, which is a simplified and automated model and transparent analytical input-output models than other machine learning approaches. Despite research into the field of prediction of wind conditions, the level of power fluctuation at large off-shore wind farms can be said to have a significant impact on the control and management strategies of their power output. In [105] the authors presented the statistical model switching method, thus demonstrating that the magnitude of fluctuation of off-shore wind power cannot be considered as being influenced by only the generation level. Some authors have reconsidered the discontinuity in the generation of wind power, taking into account more detail. Zhang and Wirth in [106] showed a model derived from the heuristic algorithm for short-term management of a wind power plant with a storage system, taking into account the dynamic of the battery, in order to offset variations in power output to the external grid, in which decision-making is independent of historical wind data and forecasts.

Because of the intermittent nature of renewable energy, such as the wind power system, many challenges arise when connecting the renewable energy system to conventional generators. Boqiang and Chuanwen in [107] presented a significant model to manage the risk in the electric

market using wind power, and evaluated in detail different optimisation techniques for this purpose, such a direct search model, PSO, SA, GA and an implementation model. To have a reliable wind plant the focus must be on rotor speed control and tip-speed ratio to maximise power and energy capture from the wind. Many researchers have used heuristic and PSO models to solve the problem [108]. Although wind generation is presented as emission-free, its effect on the thermal generation dispatch can actually cause an increase in emissions, especially during low or medium demand during the day. In [109], Kuo presents a combinatorial multi-objective function in terms of economic dispatch, minimising the fuel cost; moreover, it is environmentally friendly. Ko and Jatsekevich in [110] demonstrate the fuzzy linear quadratic regulator controller for a wind hybrid power generation system to enhance power quality, which is effective against disturbances caused by a change in the speed of the rotor, as well the load. Kusiak et al [111] developed a multi-objective function based on integrated data mining for the control of the wind turbine; the model has five sub-objectives and considers wind speed, turbulence intensity and power demand as the control variables. Li et al [112] presented an optimal design model on the integration of the number of actuators, the configuration of the actuators and the active control algorithms in buildings excited by a strong wind force using a multi-level GA.

2.5 SOLAR ENERGY

Solar energy is radiant energy that takes its origin from the sun. Among renewable technologies it is considered one of the best. The conversion technologies of solar radiation into energy are active and passive solar design. The determination of passive solar design is often based on the optimal design of buildings that capture the sun's energy in order to reduce the need for artificial light and heating. Regarding passive solar systems, basic research in solar technology is done on the design and optimal system of solar energy homes [113]. The improvement of energy in the building is important to reduce emissions and save energy. Energy saving varies in different locations and because of different policies worldwide, although all aim to offer an optimal solution. Variables are energy consumption, financial costs and environmental performance, etc. [114- 115]. This optimisation can be done by shifting the load to a different time of the day in the control horizon or by other techniques. Active solar design is based on water heating, converting solar radiation into heat using PV panels and solar cells to convert solar radiation into energy.

In the process to have a renewable energy source implemented, the location plays an important role. The radiometric station nets are used to measure the solar radiation. The authors in [116] solved the artificial intelligence techniques based on ANN to determine the solar radiation levels over complex mountainous terrain, applying data realised by only one radiometric station. Other models used in the application to forecast solar radiation are ANN [117-118] and neuro-fuzzy inference systems [119]. More development has taken place in the field of prediction in the solar forecasting model, but there is a gap in extraction of pertinent information from such data, which is why some researchers have considered artificial intelligence techniques to identify and optimise the statistics of solar radiation availability [120].

Because of the intermittent nature of the renewable energy system, the energy storage or a back-up system is an important state variable in a stand-alone system to ensure continuous power flow. The large-scale utilisation of this form of energy is possible only if effective technology can be developed for its storage, with acceptable capital and running costs [121]. Solar industry prices have been declining because of improved technology and the availability of solar systems in the market [85]. Kalogiroua in [122] determined the objective function to optimise the economic benefits of a solar energy system applying ANN and GA. ANN have been trained to learn the correlation of collector area and storage-tank size regarding the auxiliary energy required by the

system from which life cycle savings can be estimated, while GA in the model is used to estimate the optimal size of these two parameters for the optimisation of life cycle savings. Aronova et al [123] presented an objective function with the aim to maximise the energy taken from the sun, while also estimating the optimal location. In [124] the authors optimized the solar concentration, taking the parabolic cylindrical as a control variables. Garcia Fernandez et al in [125] presented an overview of the parabolic trough collectors built. Szargut et al in [126] introduced the optimal performance of a solar collector. In [127] Varun presents a GA algorithm to optimise the thermal performance of flat plate solar air heaters by taking into consideration the different method and control variables. Chang and Ko in [128] solve a combinatorial objective function that takes into consideration the heuristic method and PSO with non-linear time varying evolution in order to determine the tilt angle of PV modules with the aim of optimising the energy output of the modules. In [129] Zagrouba et al present a GA model to determine the electrical variables of PV solar cells and modules to analyse the corresponding maximum power point from the illuminated current voltage characteristic. Marston et al in [130] developed an optimal model for the design of linear concentrating solar collectors applying stochastic programming and Monte Carlo techniques to determine the collector performance in the design stage, which is taken as objective function. The algorithm modified by Krieger-Wolfowitz was applied to minimise the function.

Optimal sizing has been a factor in optimal solution in PV technologies. To size the stand-alone PV system is a more complex problem, in view of the aim to obtain optimal energy and economic cost for the consumer, as well as a relatively better power quality supply. Mellit in [131] compares the performance of artificial intelligence techniques to size the stand-alone PV, grid-connected PV and PV-wind hybrid systems. In [132] Mellit et al present ANN and GA to size a PV system. Yang et al in [133] present a sizing model for the optimisation of the capacity sizes of different components of hybrid solar-wind power generation systems using a storage system as a battery bank. In [134] Li et al present the optimisation of stand-alone PV systems, taking into consideration the storage system as its state variable applied as a constraint to the model. In Thiaux et al. [135] apply non-dominated sorting genetic algorithm II for the optimisation of stand-alone PV systems with the objective to minimise the energy flow into the battery, which means its storage capacity. In [136] Kornelakis and Koutroulis presented the optimisation of PV grid-connected systems, and it is observed that they select the optimal number and type of optimal values of the PV module installation details in such a way that the total net economic benefit achieved during the system's operational lifetime period is maximised. Kornelakis and Marinakis [137] use the PSO as a solver to the problem.

Cirre et al. in [138] analysed the hierarchical approach, which entails the fuzzy logic and the physical model based optimisation for the control of a distributed solar collector field. The results demonstrate that it is possible to have an automatic control plant and exploit solar performance while the operation is taken as a constraint to the model. In [139] Ammar presented a neuro fuzzy algorithm for a daily optimum management of household PV panel generation without any back-up to the system. To optimise a PV system, it is important to maximise the power point corresponding to the maximum efficiency according to the irradiation and cell temperatures. Other researchers have proposed an adaptive perturb and observe method that has fast dynamics and improved stability [140]. The application of water heating is currently gaining momentum and water heating is often achieved with solar energy. To have a centralised unit for water heating, better optimal implementation of the system is required, which will help to achieve energy saving. Fong et al [141] compare an EA model to maximise the energy saving of solar heating to conventional domestic heating. Kulkarni et al [142] have shown the water replenishment profile that optimises the overall system using optimisation models.

2.6 HYDRO POWER

Water power generation is the power derived from the energy of moving water to generate electricity. Since water is much denser than air, even a slow-flowing stream of water or moderate sea swell can yield considerable amounts of energy. Several forms of water power are currently in use or being developed. Broad categories include hydroelectric power, which is based on generating electrical power by using the gravitation force of falling or flowing water, and ocean energy, which mainly refers to the energy carried by ocean waves and tides [143]. Many researches have increased their research in the hydro-generation field, especially in model operation management, development and control [144]. Anagnostopoulos and Papantonis in [145] have developed a stochastic EA for optimising the sizing of a small hydro-generation plant that simulates in detail the plant operation during the year with the objective to maximise the profits as well energy output. In [146] the authors presented a development model of the capacity of a mini-hydro plant based on forecasting series model. In [147] the author developed an LP method for optimal hydro-generation energy that also compares the effect and sensitivity of the state variable and reservoir dynamic taken as a storage system on optimisation of the hydro-generation energy based on the determination of optimal values. The objective of a hydropower producer in the deregulated power market is to produce, supply and sell electricity with a maximum and minimum market risk. The business of producing the electricity is based on the profit uncertainty caused by uncertainty in spot prices and storage inflow. In [148] Honglin et al present a review on state-of-the-art technology in hydropower systems, taking into consideration the profit risk under uncertainty and suggesting future directions for additional application. In [149] Ladurantaye et al compare deterministic and stochastic models for the optimisation of profit obtained by selling electricity produced through a cascade of dams and reservoirs in a deregulated market. In most studies stochastic methods present an advantage over deterministic ones. In [150] Kuby et al developed a multi-objective function optimisation model to compare ecological economic trade-offs and to support complex decision-making associated with dam removal in a river system with the objective to minimise power loss in the system and maximise the state variable.

The control and the management of the hydrothermal generation planning is an important problem that requires the optimal amount of generated power for the hydro and thermal units of the system in the control horizon while satisfying the constraints of the models, thermal plants and electric power system. This problem has been solved by applying heuristic optimisation techniques, including a modified adaptive PSO algorithm [151]. Finardi et al present in [152] the economic dispatch in the hydro power plant connected to the hydrothermal system with the application of LR and sequential quadratic programming. In [153] Liu et al developed a stochastic LP framework for the hydro power portfolio management problem. Perez Diaz in [154] present a non-linear programming planning algorithm that solves both the optimal unit commitment and the generation dispatch of the committed units for short-term operation scheduling of a hydropower plant. The results show the good performance of the model, which provides feasible and locally optimal operational planning given by both the plant status and the power to be generated in each hour of the day in order to optimise revenue. In [155] Khanmohammadi et al determine the unit commitment problem applying NMS and PSO models; other methods, such as stochastic programming, have also been applied to this model [156]. In [157] the authors demonstrate the good performance of the PSO in the economic dispatch of hydropower generation, which is connected to renewable energy such wind generation. In [158] a combinatorial model is presented for the optimisation of the load distribution among cascade hydropower stations; the results demonstrate an optimal good load dispatch with high convergence precision. Real-time hydropower reservoir operation and management are continuous decision-making process that involves determining dynamic of the reservoir or the volume of water released from it. Hydropower operation is usually based on the operating

strategies, policies and rules that are determined during the strategic planning of the hydro plant. Moeini et al. [159] presented a fuzzy logic system for the operation of hydropower reservoirs where the rules are defined on ideal or target storage levels. To have a good run of a hydropower plant, the planning of the maintenance duration can be shortened or it can be postponed when there is expected unserved based on current water storage levels and forecast storage inflows. Foong et al [160] present a model for maintenance planning using an algorithm that combines ACO and power plant maintenance scheduling.

The combination of different power sources such as wave power and renewable energy generating sources has advantageous physical properties and predictability. Among other sources of renewable energy, the ocean waves represent one of them, generated by wind currents passing over open water. The potential wave energy varies considerably in different locations and cannot be harnessed effectively everywhere. The prediction of wind speed is a basic factor in its generation. In the same manner, the prediction of water level is the main factor of ocean generation. Huang in [161] presented a model based on the ANN for water level predictions, with an application to coastal lines taking into account the forecast of water level. Kazeminezhad et al [162] compare an adaptive network-based fuzzy inference system and coastal engineering manual models for the prediction of the wave parameters. Reikards [163] presents the ability of time-series models to predict the energy from ocean waves by a hybrid model that adds together the ANN with the time-varying regressions. Child and Venugopal [164] compare the influence of the spatial configuration of a wave energy device array upon total power output, applying two different methods: the parabolic intersection method and a GA. The results demonstrate that, although more computational effort is required, superior results may be obtained using GA compared to the parabolic intersection model.

Ocean energy technologies for generating electricity include wave, tidal (barrage and turbines) and ocean thermal energy conversion systems [85]. The author in [165] presents the optimisation model applied stochastic method for the energy conversion process from wave to air turbine, where the control variable is the turbine size, which is represented by its rotor diameter. The model is defined as a multi-objective function to maximise the electrical energy produced and the annual profit. Another interesting topic in this field is the optimisation of the shape of a wave energy collector to improve its extraction, which is solved with an intelligence model such as GA [166]. Batten et al applied [167] an NMS to design and optimise the power output with tidal data for marine current turbines.

2.7 HYBRID SYSTEM

In Power system analysis, they are different sources, conventional and renewable sources. A hybrid system can be define as a mix of more than two sources, i.e. solar and wind. The reliability of renewable sources is the main factor in ensuring continuity of supply in the renewable industry. This applies to different sectors of the industry, whether the load is domestic, commercial or industrial. For instance, commercialised stand-alone street lighting systems based on the classical configuration coupling PV cells and batteries cannot work all year round in regions that are far from the equator [168]. The technologies in the renewable energy industry must improve their performance, especially the stability of their output. It is also necessary to connect renewable energy sources to conventional sources [169]. In the last decade, there has been spectacular interest in optimisation and management of stand-alone hybrid power generation systems in order to manage energy between the maximum energy captured and consumed energy [170]. An optimal hybrid system design adds more effectiveness and reliability to the system compared to

a single system, and so there is increasing interest in determining the necessary conditions to install PW/PV power plant because of their operational and economic advantages [171]. The objective to optimise the mix of renewable energy systems to reduce the demand for power during the peak period, while minimising the combined intermittence at a minimum cost, some objective functions have been proposed [172]. Kasigiannis et al in [173] present a combinatorial objective model to minimise the energy with the cost implication of the system, while the total greenhouse gas emissions of the system during its lifetime are also minimised. The economic dispatch problem has a non-linear, non-convex type objective function with intense constraints which can equal and non-equal. Conventional optimisation methods are unable to solve the problems because of local optimum solution convergence. Mahor et al [174] used a PSO to determine the problem and the result showed that the performance was better than that of conventional optimisation techniques. In [175] the economic environmental dispatching of a hybrid power system, including wind and solar thermal energies using MOEA, which is presented as a multi-objective function that simultaneously minimises fuel costs and pollutions. Furthermore, GA is used into the optimization of economic load dispatch of power systems apply in combine renewable sources. Bernal-Augustin et al in [176] proposed MOEA to the multi-objective model for isolated hybrid systems, taking into consideration different control variables which are the total cost and pollutant emissions. The results obtained when designing a PV-wind-diesel system demonstrate the practical utility of the design method used. In another studies the authors applied a MOEA to solve a combinatorial model that contains a three-objective version of this problem. In addition to the two control variables, the unmet load in hybrid system was taken into consideration. [177]. In [178] Ould presented an objective function for sizing a hybrid system with the aim of minimising the annual cost system and the power loss. In [179] Bilal presented a Pareto-based objective function for sizing a solar-wind-battery system with a combinatorial objective function to minimise the annual cost and the probable loss of power supply. In [180] Montoya et al presented a multi-objective function of a meta-heuristic that combines PAES with SA and TS to minimise voltage and power losses.

In remote areas the renewable energy systems are more popular because of its advantages. The optimisation techniques, including LP have been discussed in [181], the fuzzy system [182]. The design of renewable energy systems as hybrid systems is more complex because of the uncertainty of renewable energy sources. Some authors discuss the way to determine the optimal combination of renewable energy technologies, taking into account not only the renewable energy resources, but also the technology characterisation, incentives and economic parameters [143]. Once again Lee and Chen [20] present a PSO to use for the wind-PV capacity coordination for a TOU rate industrial user with the objective to optimise the economic benefits of investing in a wind generation system and a PV generation system. Kaviani et al in [183] present an objective function to optimise a hybrid wind-PV-fuel cell generation system and PV generation. In [168] Lagorse et al present the GA to optimise the hybrid system. Eke et al in [184] apply an optimisation technique for the design and operation of a hybrid power generation. In [185] the authors present an optimisation method for the design and operation of a hybrid power generation.

From an economic point of view, renewable energy can be used as alternative to electricity in remote area. The solution to have an isolated network is hybridising renewable energy power sources such as wind, solar, micro-hydro systems [186]. In [187] Bernal-Augustin compares the main research strategies on optimisation of hybrid systems with the dynamic to the battery storage system. Zhou et al [21] present a basic review of the current state of the art in the optimal environment, which comprises simulation and control techniques for stand-alone hybrid solar-wind energy systems with storage systems, with the results showing that there is a large variety of technologies for accurately predicting their output and reliably integrating them with other renewable or conventional power generation sources. Other authors have analysed renewable energy sources, which comprise wind-solar-battery and DG, applying GA for the optimal power

configuration of the power system on islands [188]. Balamurugan in [189] presents a hybrid system that is combined with biomass, wind, solar PV and battery, to maximise the energy during the peak period when there is low or no solar radiation, as well as during low wind periods. In [190] Nema et al present a review of the current state of the design, operation and control requirements of the stand-alone PV solar-wind hybrid energy systems with conventional back-up sources such as a DG or grid and highlight further research in the field.

To achieve optimal design in the hybrid system, the sizing and control strategies must be the main considerations [191]. Garcia and Weisser in [192] present LP and load dispatch to analyse the size of grid units and dispatch in a wind-diesel power system with the objective function of the minimisation of cost, taking as data a one-year times series of hourly wind speed and considering electricity demand as the control variable in the main model. In [193] Koutroulis et al present GA optimisation for the sizing of stand-alone PV-wind generator systems, which selects the optimal number and type of units to minimise the cost, which is taken as objective function; the energy requirements are taken as constraints to the model. In [194] Yang et al propose the GA for optimisation for the sizing of the configuration of a hybrid solar-wind system using a battery as a storage system, where the control variables are the number of PV modules, wind turbines, batteries, the PV module slope angle and wind turbine installation height. In [195] Del Real proposes a method for the evaluation of the optimal element sizing of a hybrid power system that incorporates a wind generator, with two storage systems. In [196] Bernal-Augustin proposes a control and design applying EA for an efficient system of electrical energy generation that consists of a PV wind-diesel-batteries-hydrogen system. In [197] Zervas analyses a hybrid system that consists of a PV array electrolyser, metal hydride tanks and proton exchange membrane fuel cells, which has advantages compared to stand-alone PV systems, but the optimisation technique for its operation is a rather complex task. Diaf et al in [198] compare the estimation of the appropriate dimensions of a stand-alone hybrid PV-wind system that guarantees the energy autonomy of a typical remote consumer using the cost of the energy as constraint. In [199] Hakimi and Moghaddas-Tafreshi demonstrate the ability of the PSO in renewable energy to minimise the total cost of a hybrid power generation system driven by fuel cells, wind units, electrolysers, a reformer, anaerobic reactor and hydrogen tanks; it uses biomass as an available energy resource, such that the demand for an entire control horizon is met. The same author also uses the PSO model for the sizing of the hybrid power system to minimise the total cost of the system and meet the demands [199]. Many authors have attempted to analyse the impact of renewable energy on power system operation. Several works have recently been published in the field of renewable energy connected to the normal grid, which can be defined as micro-grids. Razak et al [200] derived an optimal model to minimise the excess energy and cost of energy in a hybrid renewable system that combines different energy sources. The results indicated the importance of considering the amount of excess energy the system produces in order to reduce energy cost. Chakraborty et al [201] propose GA and PSO for the dispatch of the thermal units integrated with the hybrid system. In [202] Matevosyan et al present a day-ahead schedule model for a multi-reservoir hydro-power system coordinated with wind power and using the same transmission power lines, though hydropower has priority for transmission capacity. Castronuovo and Lopez in [203] present an optimal model to determine the optimum daily operational strategy, which combines wind turbines and hydro generation pumping equipment. In [204] Jurado and Sanz propose an application to a neuro-fuzzy controller for a hybrid system composed, with two different sources of the renewable energy systems (wind generation and DG system) and connected in parallel with a stall-regulated wind turbine to an induction generator which are link to an AC-bus bar. Compare to others approach such as fixed –parameter fuzzy logic controllers and PID controllers, the application of fuzzy controller into new configuration, presented in [204] show a better achievement of the results. Dulo-Lopez and Bernal-Augustin [205] present a GA for the optimisation of the design and the operation control of a hybrid system composed (PV, DG, Wind generation, the hydro pump as storage system) which can be in remote or isolated areas they find out to be a better for the cost and the reliability of the system. In [206] Anagnostopoulos and Papantonis propose an algorithm for the simulation of the plant operator and automated optimisation software based on EA for optimum sizing of the various components of a reversible

hydraulic system, i.e. turbine size, the size and the number of the pumps, the penstock diameter and thickness, the capacity of the reservoirs and some financial parameters. In [207] Arnarbaev presents a new configuration applying a closed loop control algorithm for a solar system which is included with geyser to increase the temperature during any time of the day, and also to increase the hot water load replacement factor

2.8 SUMMARY

This chapter focused on the most recent research developments concerning the optimisation model for design, planning and control of renewable energy. There is increased research in the field of optimisation of renewable energy systems. Some of these optimisation models are based on traditional approaches, such as mixed integer and interval linear programming, LR, quadratic programming and NMS, and publications focus on the heuristic optimisation model. Some authors developed the model to a multi-objective one, giving direction in a discussion on many parameters involved in the optimisation process.

CHAPTER 3: OPTIMAL ENERGY CONTROL OF A GRID-CONNECTED SOLAR-WIND-BASED ELECTRIC POWER PLANT APPLYING TIME OF USE TARIFFS

3.1 INTRODUCTION

In the present context of urge energy demand, renewable energy is considered as an alternative source of clean energy, more integration of renewable sources is needed to improve the economic management of the grid. However, poor operations management of the hybrid system may lead to system deficiencies. Hence, effective energy management of the hybrid renewable plant is of great importance to ensure economical feasible system. Based on this reasoning, this chapter will be beneficial to achieve optimal operational efficiency of a hybrid renewable energy plant. A multi-objective problem is considered. The first objective is to minimise system fuel costs, while the second is to maximise energy sales to the grid, based on the TOU tariff scheme. Constraints related to the power quality, continuity of the plant power outage, grid connection restrictions and equipment safety are considered.

3.2 PROPOSED TECHNIQUES

A hybrid power plant combining wind, solar, battery and DG components can provide a variety of benefits, including improved reliability, if the aforesaid components are properly operated in the electrical distribution system. Loads and hybrid sources in a grid can be disconnected and reconnected with minimal disruption. However, efficient planning is necessary whenever a hybrid power plant connected to the grid is implemented in an electrical distribution system in order to avoid problems. As depicted in Figure 3.1, the hybrid power plant supplies the local remote load and, when required, the hybrid system can be connected to the grid to optimally inject more power into the grid so as to maximise benefits (sales) and technically improve the voltage supply into the grid.

The hybrid system described in this thesis is made of the wind system, solar system, DG and storage unit. In general, the load is met by the PV and PW generators, while the battery discharges when the PV and wind generators' output is insufficient to meet the load. During off-peak periods the PV and wind generators can produce more than the local load requirements, which may then be used to charge the battery. The DG component engages the system when the PV/wind generator or the battery cannot meet the load demand; however, the DG generator cannot charge the battery or supply the grid. As shown in equation (3.1) and presented by figure (3.1), the total energy flow to the main bus is

$$P_5(k) = P_1(k) + P_2(k) + P_3(k) + P_4(k) \quad (3.1)$$

, and the energy balancing model of the hybrid solar, wind, DG and battery power generation system is expressed as:

$$P_1(k) + P_2(k) + P_3(k) + P_4(k) - P_5(k) = 0 \quad (3.2)$$

where: $P_1(k)$, $P_2(k)$, $P_3(k)$, $P_4(k)$ and $P_5(k)$ represent the electricity generated from the solar, DG, wind, battery and energy flow to the load, respectively.

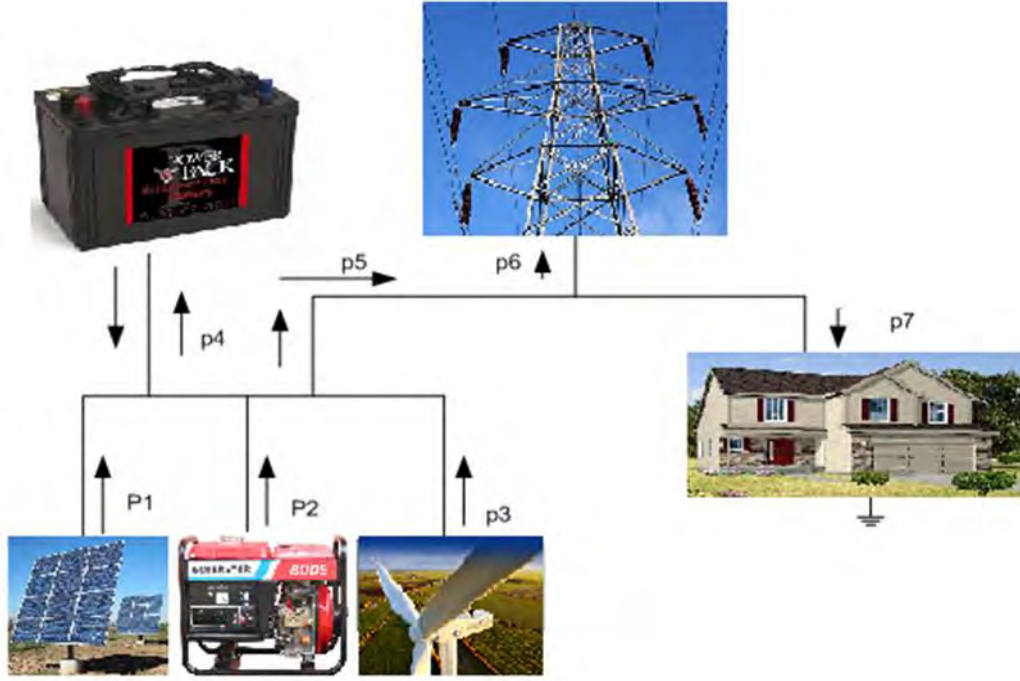

Figure 3-1: Hybrid power flow

As mentioned before, the hybrid power system must first meet the local load demand before any excess power is delivered to the grid, as illustrated in figure (3-1). The network is thus separated between the grid system and the local load. This statement is expressed by equation (3.3) to ensure that any hybrid power sold to the grid should first satisfy the requirements of the local load, which implies that any sub-source can supply the local load and the grid.

$$P_5(k) \geq P_7(k) \quad (3.3)$$

3.3 PHOTOVOLTAIC MODEL

The solar radiation that reaches the ground as a result of the apparent daily and yearly motion of the sun depends on geographical location (latitude and altitude) and climatic conditions. The output power of a PV generator (P_{PV}) is thus represented in equation (3.4) [208-209] as:

$$P_{PV} = A_c \cdot \eta \cdot I_{PV} \quad (3.4)$$

where A_c is the area surface area [m^2],

I_{PV} is the solar irradiation incident on the PV array, which is expressed in [kWh/m^2]

and η is the efficiency of the PV generator.

The efficiency of the PV generator is expressed by equation (3.5) as:

$$\eta_{pv} = \eta_R \left[1 - 0.9\beta \left(\frac{I_{pv}}{I_{pv}} \right) (T_{c,NT} - T_{A,NT}) - \beta(T_A - T_R) \right], \quad (3.5)$$

Where η_r is the PV generator efficiency measured at the reference cell temperature T_R , that is, 25°C , which relates to the standard test conditions, β represents the temperature coefficient for cell efficiency (typically $0.004-0.005/^\circ\text{C}$), and $I_{pv,NT}$ is the average hourly solar irradiation incident on the array at NT test conditions. The hourly solar irradiation incident on the PV array is a function of time of day, expressed by the hour angle, the day of the year, the tilt and azimuth of the PV array, the location of the PV array site as expressed by the latitude and the hourly global solar irradiation and its diffuse fraction [208-210]. The actual expression relies on the sky model in [211] in the study and is also discussed by [19], whereas the simplified isotropic diffuse formula suggested by references [212-213] is applied. The hourly solar irradiation incident on the PV array is presented by equation (3.6) as:

$$I_{pv} = (I_B + I_D)R_B + I_D \quad (3.6)$$

where I_B and I_D are respectively the hourly global and diffuse irradiation in kWh/m^2 . R_B is a geometric factor representing the ratio of beam irradiance incident on a tilted plane as opposed to that incident on a horizontal plane. In the 24 hours taken as the control horizon of the model the meteorological data, global irradiation, diffuse irradiation and ambient temperature are used in the evaluation of equations (3.4), (3.5) and (3.6) as the input of the performance simulation model. The evaluation is performed for each sampling time in the control horizon.

3.4 WIND MODEL

Whereas the hourly output power of the wind generator is determined by the average hourly wind speed at the hub height and the output characteristic of the wind generator, the measured data of the average hourly wind speed must be converted to the corresponding values at the hub height before calculating the output power of the wind generator. Using the wind speed at a reference height of h_r (m) from the data measured to the local site, the velocity at a specific hub height ($h(m)$) for the 24 hours, which is the control horizon of the model, is calculated using the following expression [214-215]:

$$v = v_{hr} \cdot \left(\frac{h}{h_r} \right)^\gamma \quad (3.7)$$

to determine the wind speed, on the algorithm used to calculate the out power, $P_{WT}(t)$ (W), generated by the wind turbine generator is as follows [214 – 215]:

$$P_{WT} = \begin{cases} a \cdot v^3 - b \cdot P_R & v_{ci} \leq v \leq v_r \\ P_R & v_r \leq v \leq v_{co} \\ 0 & \end{cases} \quad (3.8)$$

where the statement $a = \frac{P_R}{v_r^3 - v_{ci}^3}$ and $b = \frac{v_{ci}^3}{v_r^3 - v_{ci}^3}$ shows the relation between the wind speed and the power output.

3.4 DIESEL GENERATOR MODEL

In most cases, a DG generator is used to back up the main supply at times of shortage or when no supply is available. With this concept in mind, this work incorporated the DG into the hybrid system in order to supply the load at times when the PV, wind generators and the battery would not be able to meet the load or when no other sources are available in the hybrid system.

However, fuel costs and maintenance are the main concerns during the operation of a DG; therefore this study recommends operating the DG more efficiently by minimising its fuel operation and maintenance costs. The maximum efficiency of a DG corresponds to the rated power of the DG; therefore, the DG has to be operated between its rated power and a specified minimum value [216]

The constraint to operate a DG must take into consideration equation (3.9), which is expressed as:

$$P_2^{\min}(k) \leq p_2(k) \leq P_2^{\max}(k). \quad (3.9)$$

Switching the DG on or off in the system depends on the DG energy dispatch strategy. This determines that the DG is only switched on at times when other sub-sources are unable to supply the local load ($P_7(k)$) or grid ($P_6(k)$). The operation of the DG in the system therefore promises to be more economical in terms of DG energy, and the generator is dispatched only when there is a need to meet the local load demand. The strategy under load control determines that the DG should produce only the power required for the local load and cannot supply the grid or be used as a battery charger. According to references [217], the DG is more likely to operate at a high load factor, which will result in low specific fuel consumption and a long lifespan.

3.5 BATTERY MODEL

The battery is charged when the energy generated by the wind or the PV array and the PW exceeds the local load demand at any time during the day. However, when the load is greater than the energy generated by the sources of wind or PV arrays, the battery is discharged to cover the deficit. It can be expressed by an equation for the SOC, which is:

$$SOC(k+1) = SOC(k) - \frac{\Delta t \eta}{E_{nominal}} \sum_{i=1}^k P_4(k) \quad (3.10)$$

where: SOC is the state of charge of the battery; $P_4(k)$ is the power flow from the battery (discharge); $E_{nominal}$ = Nominal Energy, and η is the battery efficiency.

The following general equation derived from equation (3.10) applies to the battery dynamics:

$$SOC(k+1) = SOC(0) - \frac{\Delta t \eta}{E_n} \sum_{i=1}^k P_4(k) \quad (3.11)$$

, in which $SOC(0)$ is regarded as the initial SOC of the battery and $\frac{\Delta t \eta}{E_{nominal}} \sum_{i=1}^k P_4(k)$ is the power discharged by the battery at time k .

The available battery bank capacity must not be less than the minimum allowable capacity and must not be more than the maximum allowable capacity; it can be expressed by the following constraint [208]:

$$SOC^{\min} \leq SOC(k) \leq SOC^{\max} \quad (3.12)$$

Equation (3.12) can be translated into equation (3.13), the result of which the lower limit for the SOC of the battery bank cannot exceed at the time of discharging (SOC_{\min}). This may be expressed as follows [208]:

$$SOC^{\min} = (1 - DOD).SOC^{\max} \quad (3.13)$$

where, DOD is the depth of discharge expressed as a percentage.

3.6 MODEL DESCRIPTION

Electrical energy is one of the significant components in the economic development of any country in the world. With fossil fuel being the main energy source for most energy generation plants, its negative impact on the environmental sector is being considered seriously. A need exists for clean and sustainable sources of energy, such as wind, solar, tidal and small hydro generation, and so on. Yet, while hybrid systems are considered to address this need, the operation of a hybrid system may lead to poor economic performance if optimal management action is not considered.

Nowadays, DSM based on TOU tariffs (pricing) is being introduced in several countries, among others South Africa, with the aim of influencing customers to shift their power loads from peak periods to off-peak and standard periods. In this way, both power utilities and customers will benefit. On the one hand, generators at utilities will not be overloaded by meeting their reserve constraints, while on the other hand, customers can adapt their energy consumption based on a TOU tariff scheme by shifting and therefore reducing their loads during peak periods when energy is more costly to off-peak and standard periods when energy is cheaper.

Connecting a hybrid system to the national grid can also benefit from TOU tariff-based DSM by maximising the sales of hybrid energy to the grid. In peak periods, for instance, when grid energy costs are highly increased, the hybrid energy plant operator can optimally inject more power into the grid to maximise the benefits (sales). However, a second control objective, namely minimising the fuel cost of the DG, at present part of the hybrid system, has to be taken into account in the interim. System constraints such as battery SOC, power output (applied as a control variable in this work) limits of each power-generating component (PV, wind turbines, DG, etc.), power balance and so on, should be met during the control horizon.

3.7 PROPOSED MODEL

The basic conditions for the optimisation model are summarised by five control variables; the power supplied by the PV is modelled as a variable source with a profile that varies from zero to a maximum for the 24 hours. The DG is modelled as another variable power source with minimum and maximum output. The power from the wind is also modelled as a variable source, which ranges from zero to the maximum available power for the 24-hour interval, power flow into the grid and power flow from the battery. The PV and PW generators supply the local load demand as well as any surplus power sold to the grid and stores power in the battery until its full capacity

has been reached. If the PV and PW generators cannot meet the local load demand, the battery will be discharged from its maximum value until one of the PV or PW sources is able to resupply again. If these sources are unable to resupply once the battery has reached its minimum value, the DG must be able to supply the local load until either the PV or the PW can resume its task. However, during the time that the local load is being supplied by the DG, the battery cannot be recharged. Moreover, DSM, applying the TOU tariff scheme, is employed in this thesis as a combined model to be developed.

DSM, based on TOU tariffs, is applied by switching the energy produced by the renewable energy sources to the grid from peak periods to off-peak and standard periods. In this way, both power utilities and customers will benefit from the scheme. The total energy produced and sold to the grid, expressed as the integration between t_0 and t_f , is thus as follows:

$$E_c = \int_{t_0}^{t_f} p_6(t)p(t)dt \quad (3.14)$$

where: $[t_0, t_f]$ is the time period for a total cost calculation, $p_6(t)$ is the power flow from the renewable source to the grid and $p(t)$ is the TOU tariff function. As equation (3.14) is discretised by the sampling time $\Delta t = \frac{t_f - t_0}{N}$, the discrete cost function is represented by equation (3.15):

$$J = \Delta t \sum_{i=1}^k p_6(k)p(k) \quad (3.15)$$

where, Δt is the sampling time, $p_6(k)$ is the power flow from the renewable source to the grid $p(k)$ is the electricity price at the k^{th} sampling time

3.7.1 Objective Function

As mentioned earlier, the local load demand and the selling of electricity during peak times are to be met by the energy supplied by the PV and PW generators; the battery only discharges if a need exists to fill the deficit created by the said generators. However, during standard and off-peak periods, the excess energy from these two sources (PV and PW) is stored in the battery until the latter has reached full capacity. At times, the DG may also be used to supply energy in order to satisfy the local load, but not to sell energy to the grid. In fact, the DG switches off when the renewable energy sources can fully satisfy the total load and the excess energy can be sold to the grid. The economic dispatch challenge is therefore to determine the optimum scheduling of generation at any given time that minimises fuel cost while completely satisfying the demand and operating limits. The first objective function is presented by equation (3.16):

$$\text{Min } \lambda \sum_{i=1}^k aP_2^2(k) + bP_2(k) + C \quad (3.16)$$

where k represents the control horizon for the 24 hours; λ is the fuel price, and $P_2(k)$ is the control variable that represents the energy flow from the DG at any time during the control horizon.

The second objective is to maximise the sale of energy to the grid by taking advantage of the TOU electricity tariff, which is also used as input to the control strategies of the proposed model. The TOU tariff is an important parameter in this model. The maximisation of energy sales is achieved by selling more energy to the national grid during peak periods when the energy cost is higher than during off-peak and standard periods. The classification of the TOU input parameter is thus off-peak, standard and peak. This will also differ during low and high demand seasons. The objective function is rendered by the following expression:

$$- \text{Max} \sum_{i=1}^k P_6(k)P(k). \quad (3.17)$$

The two terms are combined into one objective function, which results in a multi-objective function. The first term of the objective entails the DG fuel consumption, using an economic dispatch as presented by equation (3.16), while the second term is the maximisation of energy sales to the grid using the TOU tariff as expressed by equation (3.17). Expression (3.18) presents the multi-objective function, which is assigned as the sum of two major parts; the first part indicates the use of the DG in order for the fuel costs to be minimised and the second part shows the use of energy sales to the grid by a renewable energy source.

$$\text{Min} \left(\lambda \sum_{i=1}^k (aP_2^2 + bP_2 + c) \right) - \text{Max} \sum_{i=1}^k P_6(k)P(k) \quad (3.18)$$

subject to the following constraints:

$$P_1^{\min} \leq p_1(k) \leq P_1^{\max} \quad (3.19)$$

$$P_2^{\min} \leq p_2(k) \leq P_2^{\max} \quad (3.20)$$

$$P_3^{\min} \leq p_3(k) \leq P_3^{\max} \quad (3.21)$$

$$P_5(k) + P_6(k) \leq P_1(k) + P_4(k) \quad (3.22)$$

$$P_5(k) + P_6(k) \leq P_3(k) + P_4(k) \quad (3.23)$$

$$P_1(k) \geq 0, \quad P_2(k) \geq 0, \quad P_3(k) \geq 0, \quad P_4(k) \geq 0 \quad (3.24)$$

$$p_1(k) + p_2(k) + p_3(k) + p_4(k) = p_6(k) + p_7(k) \quad (3.25)$$

Equations (3.19) to (3.21) imply that each energy source is constrained by minimum and maximum values.

The constraints in equations (3.22) and (3.23) imply that the sum of the charging power and the power supplied directly to the load from the two energy sources (PV and PW) is less than or equal to the total power from the said energy sources. Equation (3.24) ensures the load from the PV to the local load and the grid. In addition, the PW supplied by the local load and to the grid, and the power supplied by the battery to the local load are all greater than or equal to zero. Equation (3.25) shows that the power supplied by the DG, PV, PW and the battery at any time during the control horizon is equal to the demand in the same period and can therefore be referred to as a power balance equation.

As mentioned in the previous section, the PV and PW are modelled as control variable power sources during the control horizon, the battery is modelled as a storage unit with maximum and maximum available capacity levels, the DG is modelled as a control variable power source with

minimum and maximum output power, the fuel costs are modelled as a non-linear function of generator output, and the TOU tariff is modelled as a non-linear function of the tariff prices, which are peak price, standard price and off-peak price. The model has been applied using `fmincon`, a function included in MATLAB's Optimisation Toolbox, because of the non-linearity of the system. This function solves problems in a manner presented by equation (3.26). The canonical form of the constraint must be applied in this format and the basic conditions for the optimisation are:

$$\text{Min } f(x)$$

subject to the following constraints

$$\begin{cases} A \cdot X \leq b \\ A_{\text{eq}} \cdot X = b_{\text{eq}} \\ L_b \leq X \leq Ub \end{cases} \quad (3.26)$$

where, X is a binary integer vector. In this thesis it is the flow of energy from different components in the hybrid system.

The variables are responsible for the optimal process. In this problem statement they are the power flow from each line into the hybrid system as represented by X .

$$X = [x_1, x_2, \dots, x_N]^T. \quad (3.27)$$

The constraints presented by equations (3.19 to 3.23) are represented in this model as equation (3.26). The available battery bank capacity must not be less than the minimum allowable capacity and must not be more than the maximum allowable capacity; it can also be regarded as a constraint in the multi-objective function.

$$SOC^{\min} \leq SOC(0) - \frac{\Delta t \eta}{E_{\text{nom}}} \sum_{i=1}^k P_4(k) \leq SOC^{\max} \quad (3.28)$$

By introducing constraint (3.26) into equation (3.28), the model will be changed to:

$$SOC^{\min} \leq SOC(0) - \frac{\Delta t \eta}{E_{\text{nom}}} \sum_{i=1}^k P_4(k) \quad (3.29)$$

and

$$-SOC^{\min} \geq -SOC(0) + \frac{\Delta t \eta}{E_{\text{nom}}} \sum_{i=1}^k P_4(k) \quad (3.30)$$

Equations (3.29) and (3.30) are formulated as inequality constraints derived from equation (3.26), where k is the range from 1 to N . Equations (3.29) and (3.30) generate N inequality under a matrix format, and the formulated matrix has a dimension $(2N + 1) \times N$ and b is a vector with dimension N . To complete the model, constraints (3.19) to (3.22) are formulated as lb and ub to the model.

3.7.2 Data Presentation

The power demands of different consumers will vary according to their needs. Therefore the grid cannot have a constant load profile, since it varies from time to time and depends on the type of load, which can be classified as domestic, industrial or commercial. The variation in the load profile also has an impact on the flow of energy into the grid, which could be related to the price of electricity. This notion has become a significant tool in obtaining the optimal point of the energy control model in this paper, which has been referred to as the TOU tariffs. An example of such a tariff scheme, the Eskom Miniflex tariff, is employed during both high and low demand seasons. Moreover, in this study the load profile for weekdays as well as weekends was considered.

Tariff for the high demand season:

$$p(t) = \begin{cases} p_o = 0.37376 \text{ R/kWh} & \text{if } t \in [0, 6] \cup [22, 24] \\ p_s = 0.6953 \text{ R/kWh} & \text{if } t \in [6, 7] \cup [10, 18] \\ p_p = 2.2952 \text{ R/kWh} & \text{if } t \in [7, 10] \cup [18, 22] \end{cases} \quad (3.31)$$

Tariff for the low demand season:

$$p(t) = \begin{cases} p_o = 0.3358 \text{ R/kWh} & \text{if } t \in [0, 6] \cup [22, 24] \\ p_s = 0.5 \text{ R/kWh} & \text{if } t \in [6, 7] \cup [10, 18] \\ p_p = 0.76 \text{ R/kWh} & \text{if } t \in [7, 10] \cup [18, 22] \end{cases} \quad (3.32)$$

where: R is the South African currency (rand) and t is the time of any day in hours (from 0 to 24).

3.7.3 Power Sources

The proposed renewable energy source contains distributed generators as well as separate solar power, wind power and battery sources. The control variables include $p_1(k)$, $p_2(k)$, $p_3(k)$ and $p_4(k)$ expressed in (kW). Each of the solar power and wind power sources is determined by its own profile, which varies during the 24-hour period between the $[t_0, t_f]$ values of the control horizon for the model. The maximum and minimum values are divided by a N sample interval into sampling time Δt in the control horizon. A 25 kW PV generator produces about 11 kW to 15 kW in the morning and 9 kW to 20 kW in the afternoon, while 20 kW wind power produces 8 kW to 12 kW and 10 kW to 15 kW during the morning and afternoon peaks, respectively. The DG system is determined by its rated values of 4 kW and 2 kW.

3.7.4 Grid Power and Local Load

The local demands are represented by a clinic and family residences, thus the profile changes for these two kinds of loads, namely the commercial and domestic loads. The grid is supplied after the local demands have been met at different times of the day and in accordance with the control

horizon in order to maximise energy sales. The benefit to the utility is that the network can operate at its optimum performance level by reducing losses in the system.

3.8 RESULTS AND DISCUSSION

The optimisation model for the renewable energy sources connected to the grid were analysed by the *fmincon* solver. The sale of energy, DG fuel and the battery SOC were analysed during peak, standard and off-peak periods. In the case of energy sales, the high demand season (June to August), during a weekday, was used. In this instance, the TOU tariff scheme was derived from equation (3.21). Figures (3-2), (3-4), (3-6) and (3-8) show the energy flow during the 24-hour period. At night and in the early morning the load was met by either the battery or the DG system. Generally, PV and PW outputs supplied the load and charged the battery. Equations (3.17) and (3.19) were satisfied, implying that the output of the renewable energy sources had to be equal to or greater than the load in order to satisfy the local load or sales into the grid during peak times and to charge the battery. As stated earlier, the DG only switches on when the renewable energy source and the battery cannot satisfy the load, especially during the high demand season. In contrast, during the low demand season, the DG operates for only a few hours and the load demand is met by the renewable energy sources and the battery.

Generally, the battery bank is charged during the day and supplies the load mostly at night when there is no power flow from the renewable energy sources. During the early hours of the morning the load is usually met by the DG, PV, PW and the battery. The DG turns off when the renewable energy sources produce sufficient power to meet the load demand or when such sources and the battery combine to meet the load demand, as illustrated in figures (3-6) and (3-8). The DG operation and the amount of power supplied by the DG rely on the SOC of the battery and the amount of power flowing from the renewable energy sources.

During the high demand season, the DG operates for more hours and generates more power if the output from the renewable energy sources and the battery is low. Therefore, seasons have an impact on energy generation and load demands, especially affecting the diesel dispatch strategy. As shown in figures (3-2) and (3-4), during the morning peak the local load demand is met by solar, DG and wind sources. Any excess energy will be contributed to sales to the grid. The PV and the wind outputs will continue to charge the battery until the SOC is within its limits.

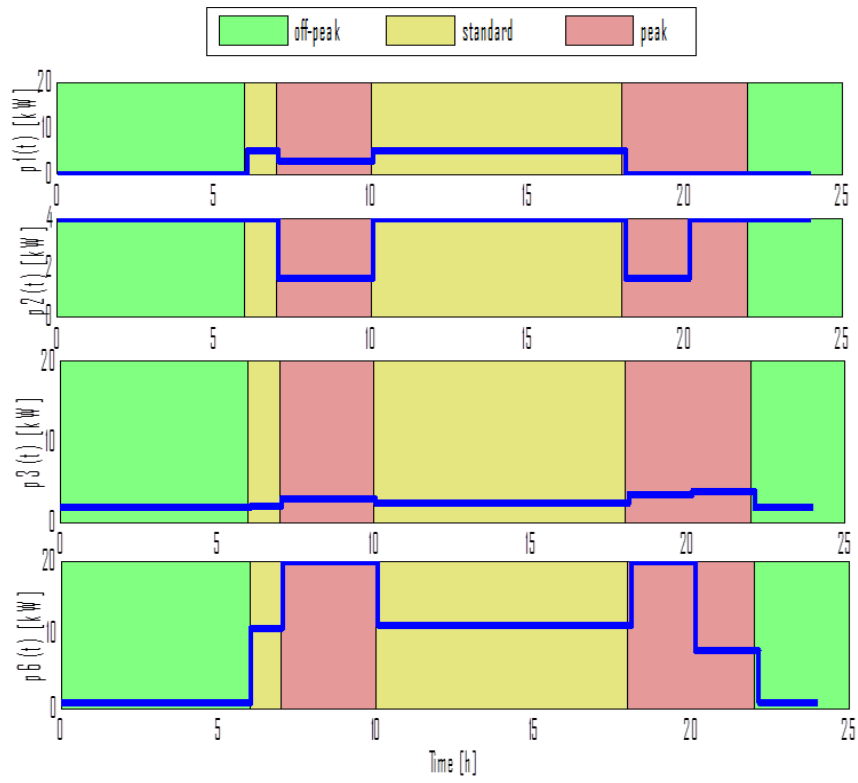

Figure 3-2: High demand season – weekday power flow

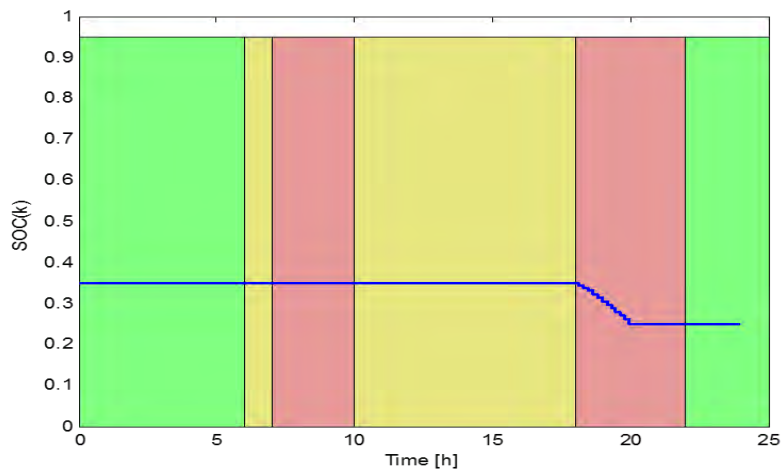

Figure 3-3: Dynamic of the battery

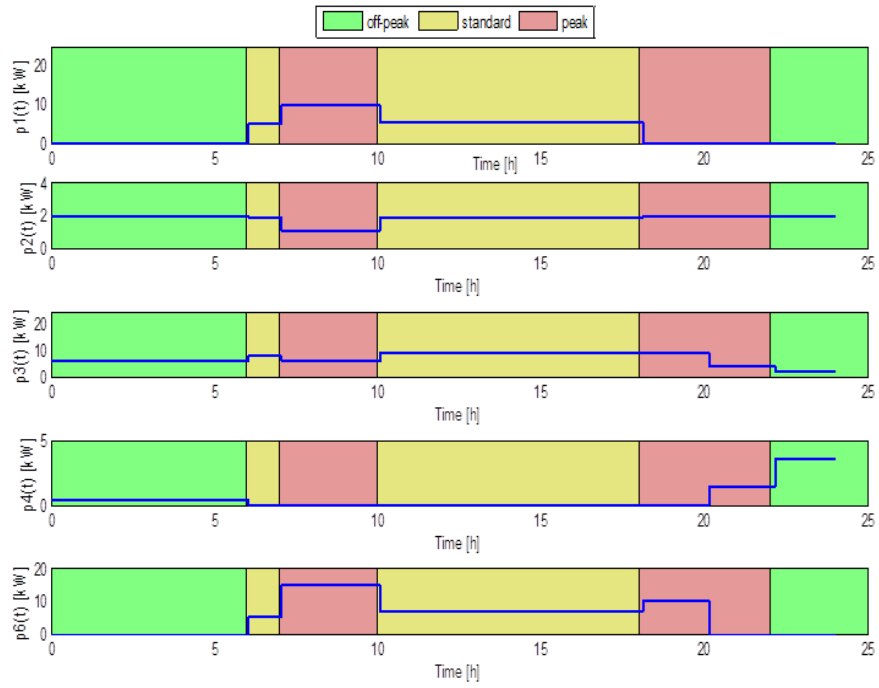

Figure 3-4: High demand season – weekend power flow

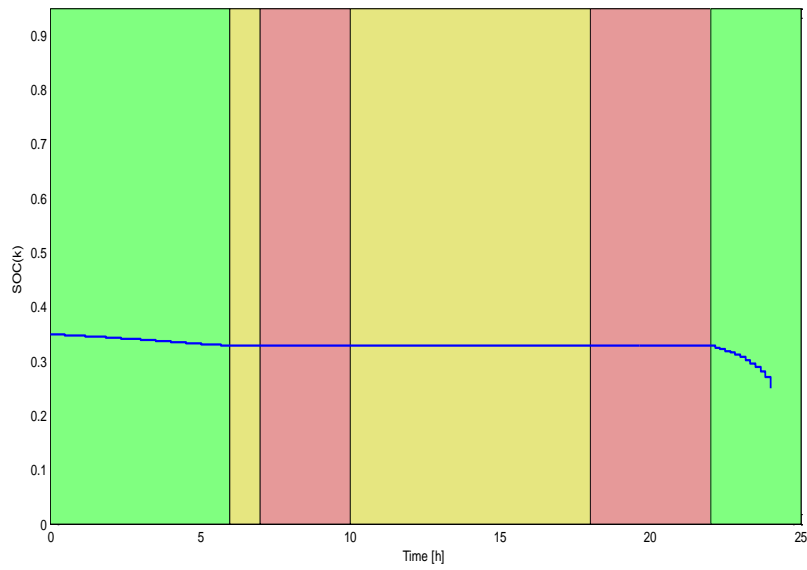

Figure 3-5: Battery state of charge

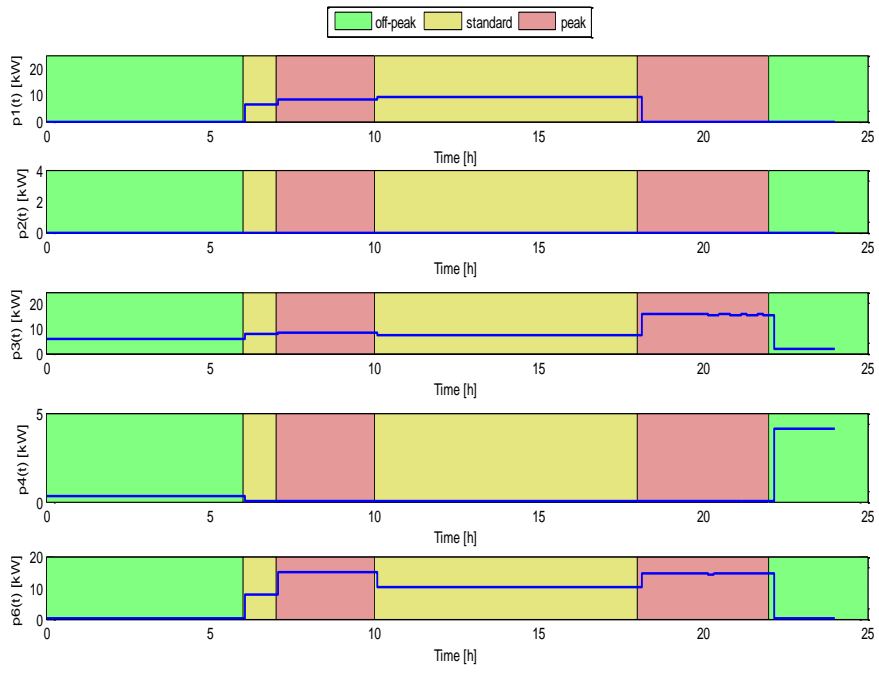

Figure 3-6: Low demand season – weekday power flow

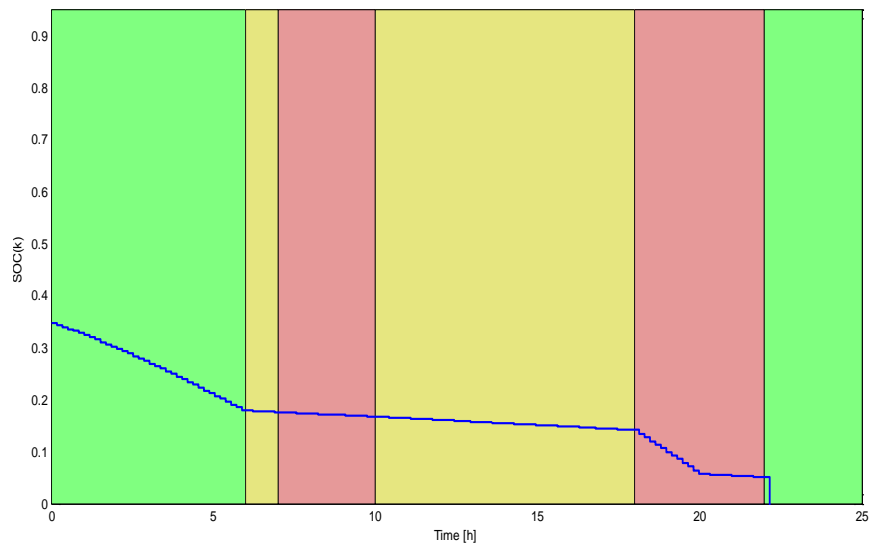

Figure 3-7: Charge and discharge of the battery

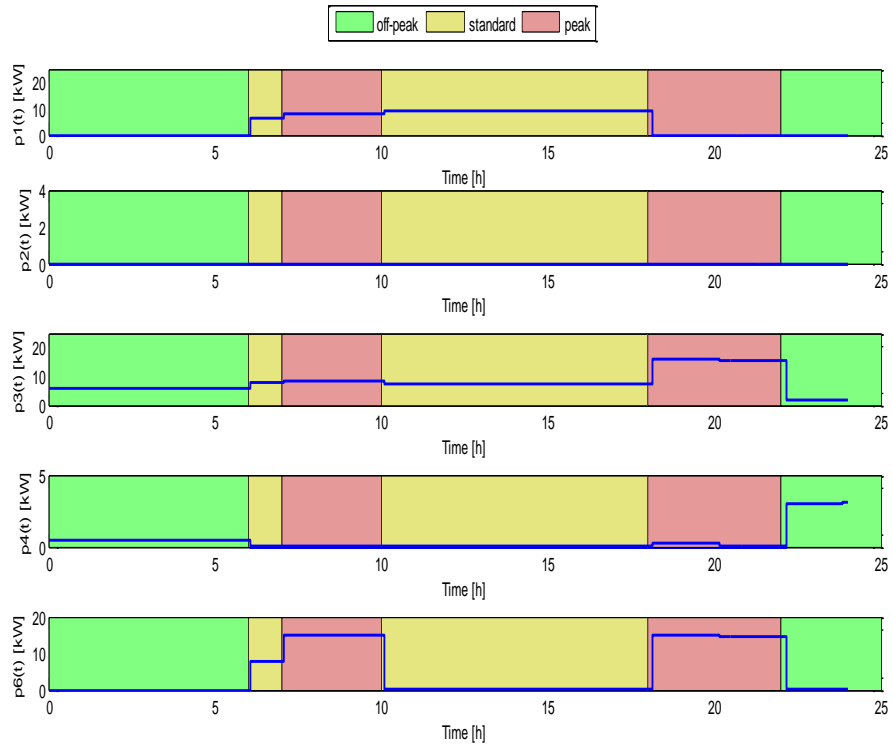

Figure 3-8: Low demand season – weekend day power flow

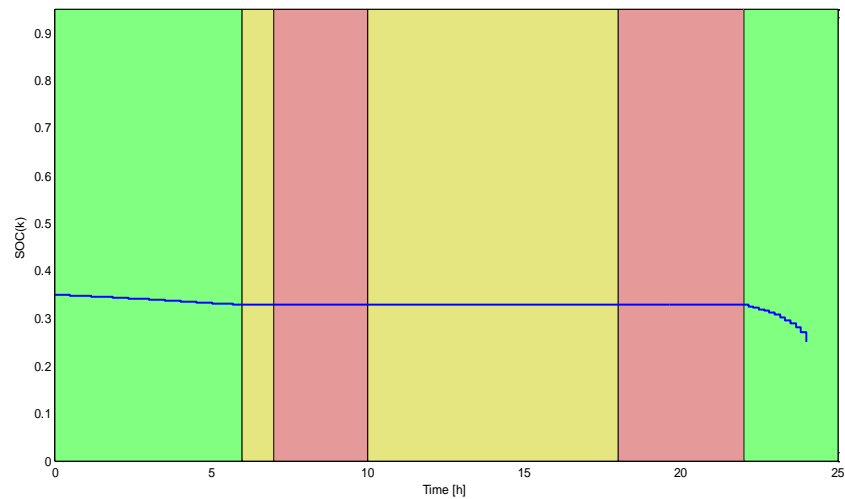

Figure 3-9: Battery state of charge.

Figures (3-3), (3-5), (3-7) and (3-9) indicate the SOC and discharge of the battery. The battery will charge mostly during the day and after 20:00 the battery will discharge for almost three hours, as determined by equation (3.28). The results have demonstrated that the load demand is satisfied by the DG, PW, PV and battery sources. The pricing structure for the low demand season has been calculated according to equation (3.26).

According to Figure (3-6), the PV and PW generators have mostly met the local load during off-peak times. Therefore the battery is only tasked with supplying the load demand, but not selling to the grid, after 10 pm. Energy sales have thus been maximised during the two peak periods; the morning peak and the night peak. The DG operations are therefore minimised for the entire day during the low demand season, which implies that the PV and PW outputs can meet the load demand and the battery will take charge during the night to back up the supply.

The difference between Figure (3-6) and Figure (3-8) is that Figure (3-8) depicts a scenario for a standard period (during the day) when no energy sales to the grid will be made because people will be at home and the power output from the PV and PW generators can only satisfy the local load. In other words, no excess energy is available for sales. Thus the only time that sales are maximised is during the two peak periods mentioned above. Also, the DG output will be zero, as the PV and PW outputs will meet the load demand, as depicted in Figure (3-8). The model developed in this thesis further indicates that the battery is charged by the renewable energy sources only and that the DG supplies the load when it is switched on.

Table 3 - 1: Daily energy sold to the grid (high season demand, weekday)

Time (h)	Period	Energy (kWh)	Sale (Rand)
7 – 9	Peak	30.5	69.845
6 – 7	Standard	15.25	10.59
10 – 18	Standard	51.6	35.862
18 – 22	Peak	48.75	111.891
			228.188

Table 3-1: Daily energy sold to the grid (high season demand weekend)

Time (h)	Period	Energy (kWh)	Sale (Rand)
6 – 7	Standard	15.2	10.564
7 – 9	Peak	45.75	105.0054
10 – 18	Standard	40.96	28.467
18 – 20	Peak	20.42	46.867
			190.89

Table 3-2: Daily energy sold to the grid (low season demand, weekday)

Time (h)	Period	Energy (kWh)	Sale (Rand)
6 – 7	Standard	8.42	4.21
7 – 9	Peak	32.24	24.504
10 – 18	Standard	34	17
18 – 22	Peak	64.8	49.248
			94.962

Table 3-3: Daily energy sold to the grid (high season demand, weekend)

Time (h)	Period	Energy (kW/h)	Sale (Rand)
6 – 7	Standard	10.4	5.2
7 – 10	Peak	52.8	40.128
18 – 22	Peak	66	50.16

Total			95.488
-------	--	--	--------

Tables 3-1 to 3-4 present the energy sold to the grid at different times of the day. In most cases the sale of energy has been maximised during peak periods to meet load demands that have arisen. Maximising energy sales during peak times will not only contribute to the power quality of the network, but also to the profit margins, as it means taking advantage of the TOU tariff scheme. With more energy sold during peak times, more profit can be expected from renewable energy sources. To determine the price of energy supplied to the grid, equations (3.26) and (3.27) are applied at different periods of the day.

Table 3-4: Fuel saving cost (in rand, which is the South African currency)

	High demand season weekend	High demand season weekday	Low demand season weekend	Low demand season weekday
Diesel application only	R 606.52	R 548.7	R 515.6	R 446.04
Hybrid system	R 155.76	R 133,34	R 99.12	R 80.24
Saving cost	R 450.76	R 415	R 416.88	R 365.8

The results in Table 3-5 indicate the cost savings on diesel for the high demand and low demand seasons, and for weekdays and weekends. The cost savings on diesel is obtained from the difference between the diesel application only and the remaining other sub-sources in the control horizon. The hybrid system, which comprises the PV, PW, DG and battery sources, achieved 81.6% and 83.2% fuel savings in the high demand season, and 87.4% and 91.3% fuel savings in the low demand season on weekends and weekdays, respectively. This comparison can be seen in the difference of the two components in Table 3-5. The cost difference can determine the benefit of minimising the fuel cost applied as the objective function in the optimisation model.

3.9 SUMMARY

Connecting the renewable system to the national grid can benefit from TOU tariff-based DSM by maximising the sales of renewable energy to the grid. In peak periods, for instance, when the energy cost to the grid is much higher, the hybrid energy plant operator can optimally inject more power into the grid to maximise sales. This chapter has presented optimal energy control for renewable energy sources, which consist of PV, DG, PW and battery sources. Furthermore, the flow of energy at different times has been analysed in the proposed model.

The optimisation model developed in this chapter has achieved savings on the use of the DG and energy sales have been maximised by injecting the excess energy produced by the renewable sources after the local load demand had been met into the grid, mostly during peak periods and sometimes during standard periods as well when the network was under stress. This enabled the utilities to lower their losses and carbon dioxide emissions.

The results of this study indicate that minimising the use of the DG has been especially significant during the low demand season, whereas the maximisation of sales has occurred during both the high demand and the low demand seasons. The battery is used mostly at night when the PV and PW outputs are unable to meet the load demand. These results further reveal that seasons are an important element to consider, as they affect the use of the DG and the flow of energy.

CHAPTER 4: OPTIMAL ENERGY CONTROL OF A GRID-CONNECTED SOLAR-WIND SYSTEM WITH PUMPED HYDRO STORAGE

4.1 INTRODUCTION

In this chapter a multi-objective model function is considered to maximise the sale of the energy to the grid. The hydro pump is introduced as a storage system to replace the batteries. The integration of the renewable energy sources to grid will improve management and the control for the entire system. The effective energy management and control of the hybrid plant is of great importance to ensure economically feasible system.

4.2 PRINCIPLE OF OPERATION

Figure 4-1 represents the main system in this chapter, which is composed of two power generators (PV array and wind turbine). Local loads are represented by a clinic and houses, and a grid that is an interconnection between the grid and the renewable source.

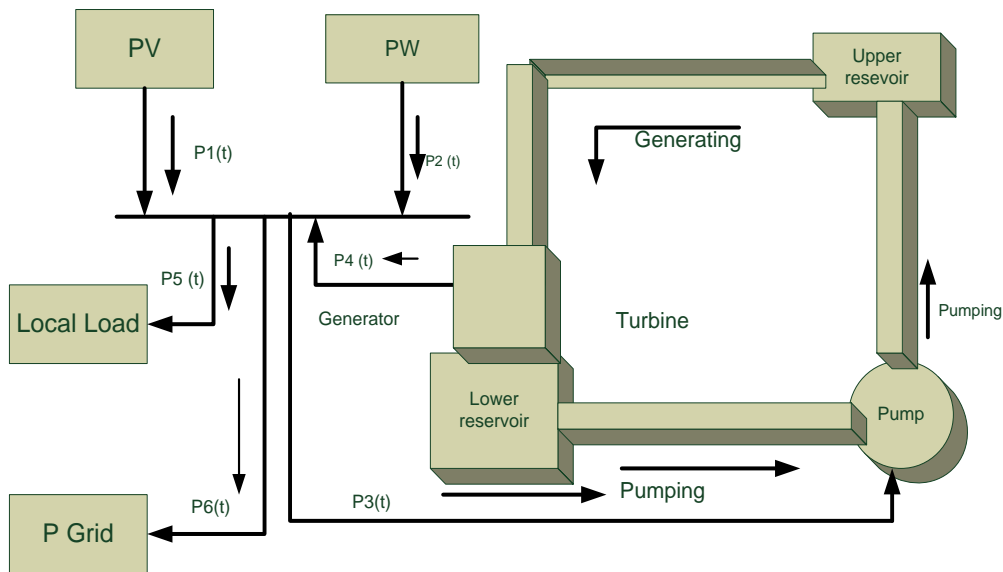

Figure 4-1: A hybrid solar-wind system with pumped storage system

The conversion of renewable energy into mechanical energy or mechanical energy into electrical energy is used as energy storage supplies to the system. The role of storage in this chapter is to mitigate the intermittency of renewable energy sources in order to balance the fluctuating demand, thus maximising the sale of energy to the grid. With the added benefit of TOU tariff-based DSM, the sale of hybrid energy to the grid can also be maximised. During peak periods, for instance, when grid energy costs are higher, the hybrid energy plant operator can optimally inject more power into the grid so as to maximise the benefit (sales). However, the aim should always be to influence customers to shift their loads from peak periods to off-peak and standard periods.

In this manner, both the power utility and the customers will benefit from the aforesaid scheme. On the one hand, the utility will meet its reserve constraints by avoiding overloading in its

generators, while on the other hand, customers can adapt their energy consumption based on TOU tariffs by shifting (reducing) their loads from peak periods when energy is more costly to off-peak and standard periods when energy is cheaper. The principle of operation of a renewable energy source entails the following: The water is pumped by the motor (P_3) as depicted in Figure (4-1) from the lower reservoir or river to the upper reservoir, and by using the excess energy supplied by the main bus, PV (P_1) and wind (P_2) are produced. The stored water is then allowed to flow to the lower reservoir to turn the turbine and generate energy (P_4) back to the main bus to be used during peak times and to provide energy for sale to the grid. In this manner, a reliable source of energy is guaranteed for 24 hours.

4.3 DESIGN MODEL

The PV and The PW are described in detail in the previous chapter.

4.3.1 Pump hydro storage

In this chapter, the PHS system is selected as the energy storage system and consists of a pump unit and a turbine generator unit.

4.3.1.1 Pump unit

The pump is directly supplied by the main bus where the renewable energy source is connected, and the flow rate drawn from the lower reservoir by the pump is expressed by equation (4.1),

$$q_{in} = \frac{\eta_p \cdot P_3(k)}{\rho g h} = c_p \cdot P_3(k) \quad (4.1)$$

where $P_3(k)$ is the power supplied by the main bus to the pump, h is the elevating head (m), g is the acceleration due to gravity (9.8 m/s^2), ρ is the density of water (1000 kg/m^3), η_p is the overall pumping efficiency and c_p is the water pumping coefficient of the pump unit (m^3 / kWh)

4.3.1.2 Turbine generator

When the renewable energy source cannot meet the demand, the upper reservoir is responsible for drawing the water to operate the generator and supply the main bus in order to turn the turbine. This can be expressed by equation (4.2):

$$P_4(k) = c_t \cdot q_{out} \quad (4.2)$$

Where: $P_4(k)$ is the power supplied by the generator to the main bus, q_{out} is the water volumetric flow rate input into the turbine (m^3/s) and c_t is the turbine generating coefficient (kWh/m^3).

4.3.1.3 Water storage reservoir

The water storage reservoir is modelled to meet the load demand during the period when the renewable energy source is unavailable. In addition, the power output from the renewable energy and the load demand at an hour t , determines the charge (pumping) or discharge (generating) power into and out of the reservoir respectively, k is an integer representing the k th hour interval. Thus, the flow of the water in the reservoir at any hour k , $v(k)$, depends on the flow of the water in the previous hour. At any given hour, the water flow in the reservoir will be rendered by the expression:

$$V(k+1) - V(k) = \Delta t \left(c_p P_3(k) - \frac{1}{c_t} P_4(k) \right). \quad (4.3)$$

The following general expression derived from equation (4.3) applies to the reservoir dynamics:

$$V(k+1) = V(0) + \Delta t c_p \sum_{i=1}^k P_3(k) - \Delta t \frac{1}{c_t} \sum_{i=1}^k P_4(k) \quad (4.4)$$

where $V(0)$ is considered the initial level of the water in the reservoir, $\Delta t c_p \sum_{i=1}^k P_3(k)$

represents the pumping power at any time, and $\Delta t \frac{1}{c_t} \sum_{i=1}^k P_4(k)$ is the generating power at any

time. The water in the upper reservoir must be maintained at a certain limit; therefore it must not be less than the minimum allowable level V^{\min} and not higher than the maximum allowable level of the water in the reservoir V^{\max} .

$$V^{\min} \leq V(k) \leq V^{\max} \quad (4.5)$$

4.3.2 Optimisation

The TOU tariff scheme has been employed in the mining sector to facilitate better system performance and to save on the cost of electricity. In [223] the efficiency of applying a conveyor belt has been emphasised in the application of TOU to show that a great saving on energy costs is achievable. To maximise the energy supply to the grid by using renewable energy sources, optimal control must be introduced and the energy cost must be taken as a typical indicator to measure the sales performance of the grid. The total electricity cost in a period is the related energy cost in the period, which can be expressed as:

$$E_C = \int_{t_0}^{t_f} p_6(k) p(k) dk \quad (4.6)$$

where $[t_0, t_f]$ is the period of a total cost calculation, $p_6(k)$ is the power flow to the grid from the sampling time $\Delta t = \frac{t_f - t_0}{N}$, and $p(k)$ is the TOU tariff function. The equation (4.6) is discretised by equation (4.7):

$$J = \Delta t \sum_{i=1}^k p_6(k) p(k) \quad (4.7)$$

where Δt is the sampling time and $p(k)$ is the electricity price at the k^{th} sampling time.

4.3.2.1 Objection function

The first objective is to maximise the sale of energy to the grid by taking advantage of the TOU electricity tariff, which is also used as input to the proposed model control strategies. The TOU tariff is an important parameter in this model. As stated earlier, the maximisation of energy sales is achieved by selling more energy to the national grid during peak periods when the cost of energy is higher than during off-peak and standard periods.

The classification of the TOU input parameter is off-peak, standard and peak, which also differs during the low and high demand seasons. Consequently, the objective function is presented by the following expression:

$$- \max \sum_{i=1}^k P_6(k) P(k). \quad (4.8)$$

The second objective is to minimise the energy supplied by the main bus to the pump (P_3) and is expressed by:

$$\min \sum_{i=1}^k P_3(k). \quad (4.9)$$

The combination of the two objective functions renders the multi-objective function for the purpose of optimisation and is expressed by:

$$- \max \sum_{i=1}^k p_6(k) p(k) + \min \sum_{i=1}^k p_3(k). \quad (4.10)$$

4.3.2.2 Constraints

The constraints of this optimal control problem are listed as follows:

1. Equation (4.11) implies that the power supplied by the PV, PW and the hydro pump is equal to the total power supplied and the Kirchhoff law, which is applied to determine the total power in the main bus.

$$P_1(k) + P_2(k) + P_4(k) = P_3(k) + P_5(k) + P_6(k) \quad (4.11)$$

- Equation (4.12) ensures that the power supplied by the PV, PW and the hydro pump at any hour of the day equals that of the local load and the load to be supplied to the grid during the peak period.

$$P_1(k) + P_2(k) + P_4(k) \geq P_5(k) + P_6(k) \quad (4.12)$$

- Equation (4.13) ensures that the power supplied by the PV, PW and the hydro pump directly to the local load or to the grid is greater than or equal to zero.

$$P_1(k) \geq 0; P_2(k) \geq 0; P_4(k) \geq 0 \quad (4.13)$$

- Each energy source i is constrained by minimum and maximum values as specified in equation (4.14):

$$P_i^{\min} \leq P_i(k) \leq P_i^{\max} \quad (4.14)$$

- Equation (4.15) ensures that the water in the upper reservoir will not be less than the minimum value or higher than the maximum value

$$V^{\min} \leq V(0) + \Delta t \cdot c_p \sum_{i=1}^k P_3(k) - \Delta t \cdot \frac{1}{c_t} \sum_{i=1}^k P_4(k) \leq V^{\max} . \quad (4.15)$$

For all $t=1, \dots, N$ is the sampling time. $P_1(k), P_2(k)$ and $P_4(k)$ are the control variables representing the energy flow from the PV, PW and the energy supplied by the PH system to the load at any time (t) respectively, while $P_3(k), P_5(k)$ and (P_6) are the variables representing the energy flow to the pump, the energy flow to the local load and the energy flow to the grid respectively.

4.4 APPLICATION OF THE MODEL

The model was applied using *fmincon*, a MATLAB function, and was selected because of the non-linearity of the system, which means that it has a multi-objective function and constraints. To derive the constraints as adapted by the model, the canonical form of the constraint must be applied to this format and has the following general form:

Min $f(x)$

subject to the following constraints

$$\begin{cases} A \cdot X \leq b \\ A_{eq} \cdot X = b_{eq} \\ L_b \leq X \leq Ub \end{cases} \quad (4.16)$$

X is a binary integer vector. In this chapter, it is the flow of energy from different components in the hybrid system. It can be formulated by

$$X = [x_1, x_2, \dots, x_N] \quad (4.17)$$

The constraints presented in equations (4.11 to 4.15) are represented in this model as equation (4.16). The hydro pump should compensate for possible over production of the renewable energy source. However, it is important to reserve storage capacity in the reservoir at all times, therefore the reservoir must never be filled to its capacity. The changes of water flow in the upper reservoir can be expressed as:

$$\Delta V = t_s \left(c_p P_3(k) - \frac{1}{c_t} P_4(k) \right). \quad (4.18)$$

Taking into consideration the above, the constraint in equation (4.16) applied to equation (4.18) will change to

$$V^{\min} \leq V(0) + \Delta t \cdot c_p \sum_{i=1}^k P_3(k) - \Delta t \cdot \frac{1}{c_t} \sum_{i=1}^k P_4(k) \quad (4.19)$$

and

$$-V^{\min} \geq -V(0) - \Delta t \cdot c_p \sum_{i=1}^k P_3(k) + \Delta t \cdot \frac{1}{c_t} \sum_{i=1}^k P_4(k). \quad (4.20)$$

Equations (4.19) and (4.20) are formulated as an inequality constraint from the model of equation (4.16), where k is the range from 1 to N , and equations (4.19) and (4.20) generate N inequality under a matrix format; the formulated matrix consists of dimensions $(2N + 1) \times N$ and b is a vector with dimension N .

4.4.1 Model parameters

The power demands of different consumers vary according to their specific needs. Therefore, the grid cannot have a constant load profile, since it varies from time to time and depends on the load type, which can be classified as domestic, industrial or commercial. The variation in load profile has an impact on the flow of energy to the grid, which could be related to the price of electricity. This price has become a key focus of the energy control model in this chapter, which has been referred to as the TOU tariff. The Eskom Miniflex tariff is employed during both high and low demand seasons. Moreover, in this study the load profile for weekdays as well as weekends was considered.

Tariff for the high demand season:

$$p(t) = \begin{cases} p_o = 0.37376 \text{ R/kWh} & \text{if } t \in [0, 6] \cup [22, 24] \\ p_s = 0.6953 \text{ R/kWh} & \text{if } t \in [6, 7] \cup [10, 18] \\ p_p = 2.2952 \text{ R/kWh} & \text{if } t \in [7, 10] \cup [18, 22] \end{cases} \quad (4.21)$$

Tariff for the low demand season:

$$p(t) = \begin{cases} p_o = 0.3358 \text{ R/kWh} & \text{if } t \in [0, 6] \cup [22, 24] \\ p_s = 0.5 \text{ R/kWh} & \text{if } t \in [6, 7] \cup [10, 18] \\ p_p = 0.76 \text{ R/kWh} & \text{if } t \in [7, 10] \cup [18, 22] \end{cases} \quad (4.22)$$

Where R is the South African currency, rand, and t is the time of any day in hours (from 0 to 24).

4.4.2 Power sources

The renewable energy source contains solar power, wind power and the PH system. The control variables include $p_1(k)$, $p_2(k)$, $p_3(k)$ and $p_4(k)$ and are expressed in kW. Each of the solar power and wind power sources is determined by its own profile, which varies during the 24-hour period between the $[t_0, t_f]$ values of the control horizon for the model. The maximum and minimum values are divided by a N sample interval into sampling time Δt in the control horizon. A 25 kW PV generator produces about 11 kW to 15 kW in the morning and 9 kW to 20 kW in the afternoon, while 20 kW wind power produces 8 kW to 12 kW and 10 kW to 15 kW in the morning and afternoon peaks respectively.

4.4.3 Grid and local load profile

The local demands are represented by a clinic and family houses. The profile will change with two kinds of loads, a commercial load and a domestic load. Energy is supplied to the grid in order to maximise sales when the local demands in the control horizon have been met at different times of the day. The benefits to the utility are thus that the network can operate optimally by reducing losses into the system.

4.5 RESULTS AND DISCUSSION

Figures (4-2), (4-4), (4-6) and (4-8) depict the energy flow during the 24-hour period. At night and in the early morning the load is met by the PHS system and sales to the grid are maximised during the peak periods. Constraints (4.16) and (4.17) are met by ensuring that the power supplied by the PV, PW and the hydro pump system at any hour of the day is equivalent to that of the local load and the load supplied to the grid during the peak period; it must thus be equal to or greater than the combined loads. The dynamics of the reservoir are demonstrated in figures (4-5), (4-7), (4-9) and (4-11).

Generally, the pump runs ($P_3(k)$) during peak hours and mostly supplies the load at night when there is no power supply from the PV and PW. The PH system will turn off when the PV and PW produce enough power to meet the load demands and to pump water into the upper reservoir. As is evident from figures (4-2), (4-4), (4-6) and (4-8), the power supply from the PV and PW is insufficient to meet the combined load demand at night and in the early hours of the morning; however, the PV and PW output continues to increase to the point when it produces more than the load requires and is able to pump water to the upper reservoir. At that stage, the turbine switches off until the PV and PW are unable to produce sufficient energy to meet the local load and the load to the grid. The turbine running time and the amount of power supplied by the PH system thus depend on the water stored in the upper reservoir and the amount of power produced by the renewable energy sources. It has been found that the PH system runs for more hours and generates more power when the outputs from the renewable energy sources are low.

Figures (4-2) and (4-4) illustrate the weekday and weekend power flows during the low demand season, while figures (4-6) and (4-8) reveal the weekday and weekend power flows during the

high demand season. The graphs indicate how the variations in seasons affect the supply and demand of the load. In the low demand season the renewable energy sources supply more power and the sale between the two peaks is maximised. However, the PH system supplies less power during the low demand season than during the high demand season. The higher power supplied during the low demand season is attributed to higher PV output to the local load and to low energy consumption.

The observation made from figures (4-6) and (4-8) is that during the high demand season the renewable energy sources cannot meet the energy demand for the standard period when only the PH system increases its output power to meet the demand load. Another important observation is that when $P_3(k)$ is switched on, $P_4(k)$ cannot be switched on; in other words, when the motor is running to pump water to the reservoir, the turbine cannot run. This is evident in figures (4-2), (4-4), (4-6) and (4-8).

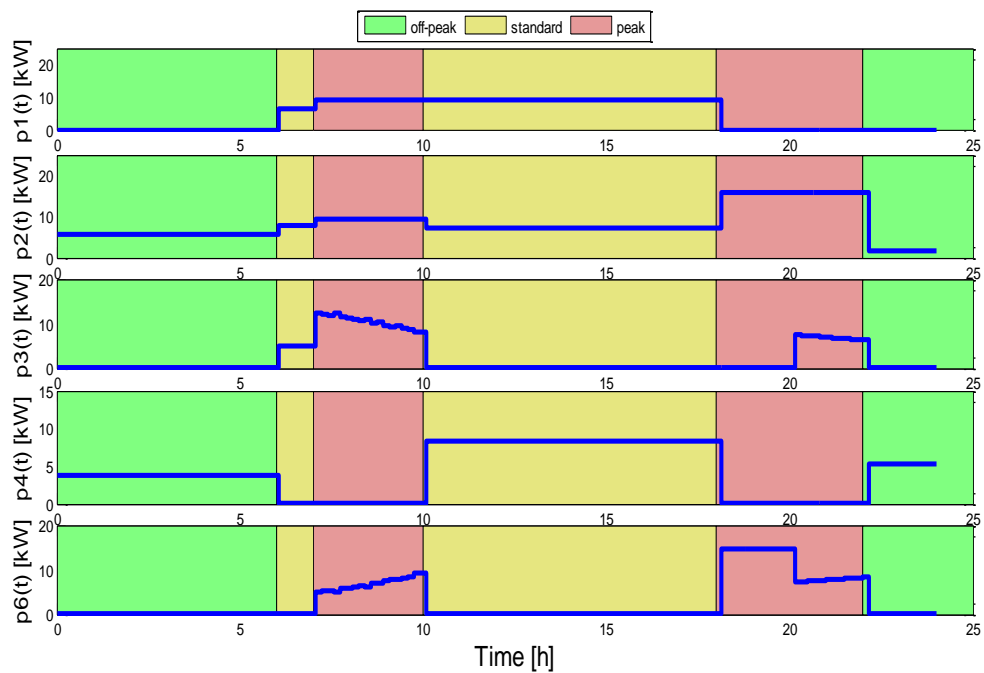

Figure 4-2: Low demand season – weekday power flow

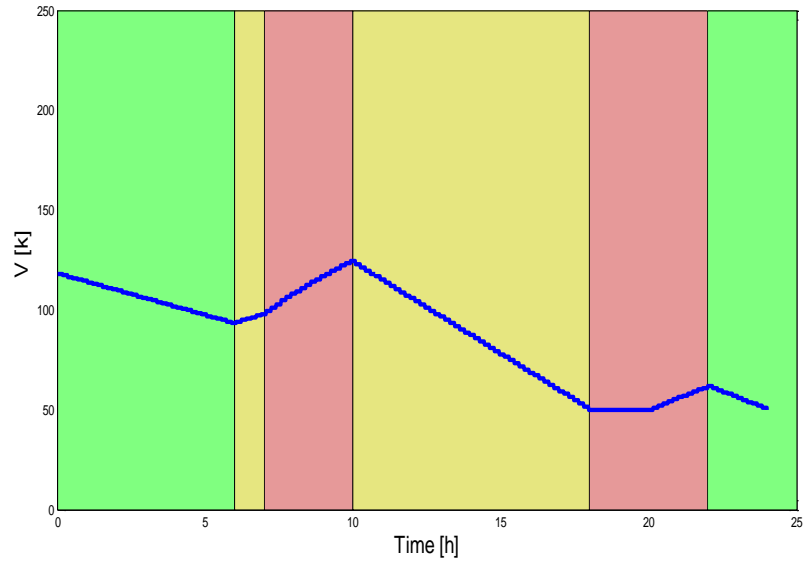

Figure 4-3: Reservoir dynamic (low demand season - weekday)

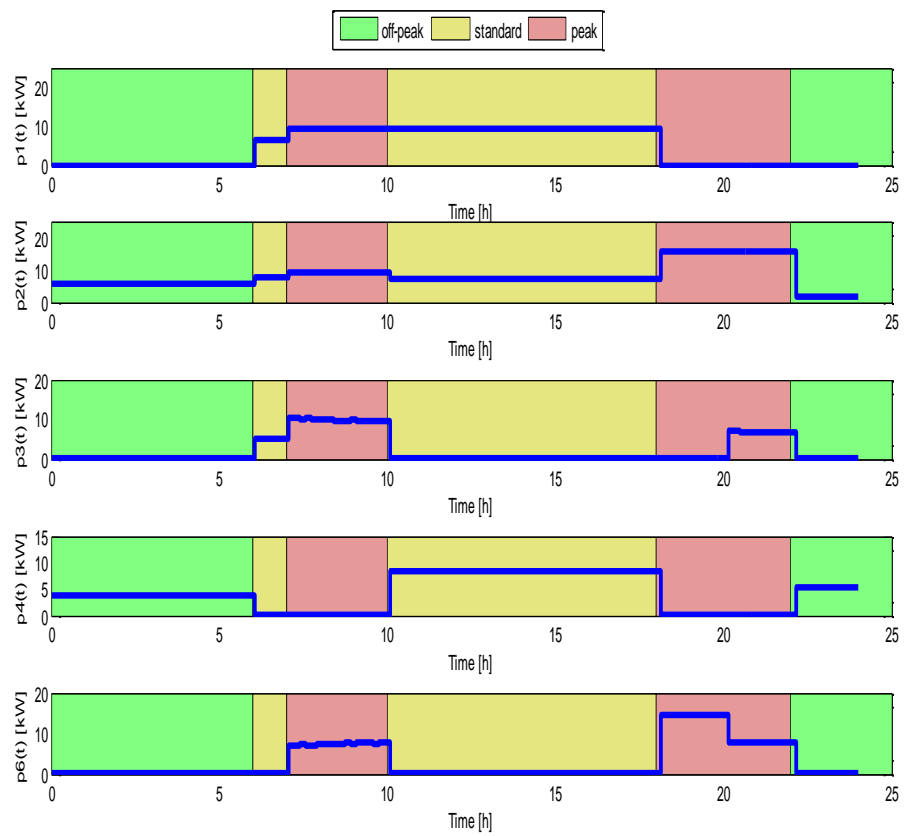

Figure 4-4: Low demand season – weekend power flow

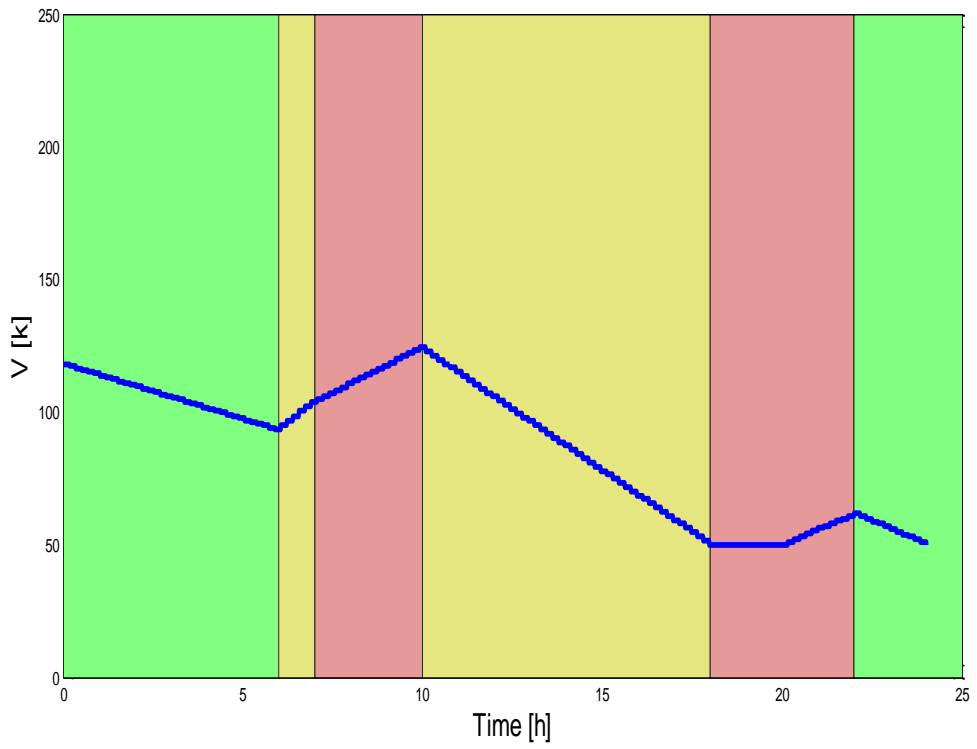

Figure 4-5: Reservoir dynamic (low demand season weekend)

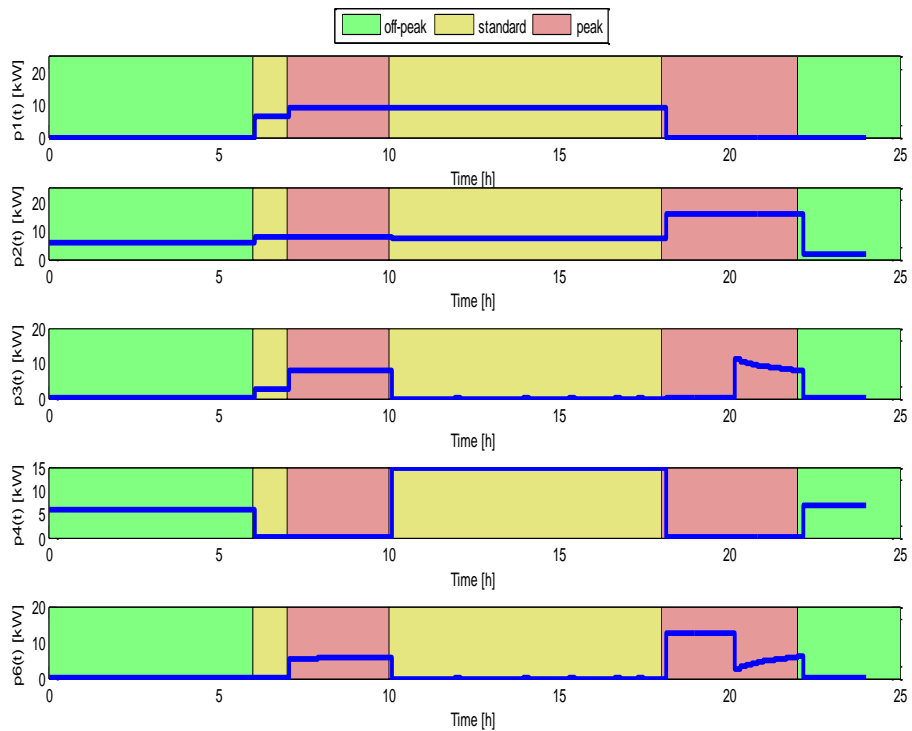

Figure 4-6: High demand season – weekday power flow

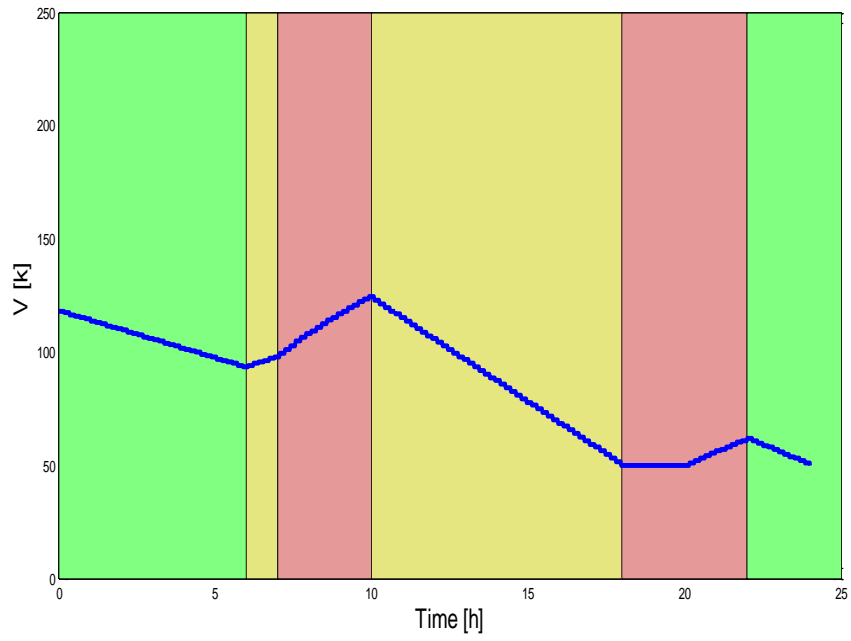

Figure 4-7: Reservoir dynamic (high demand season weekday)

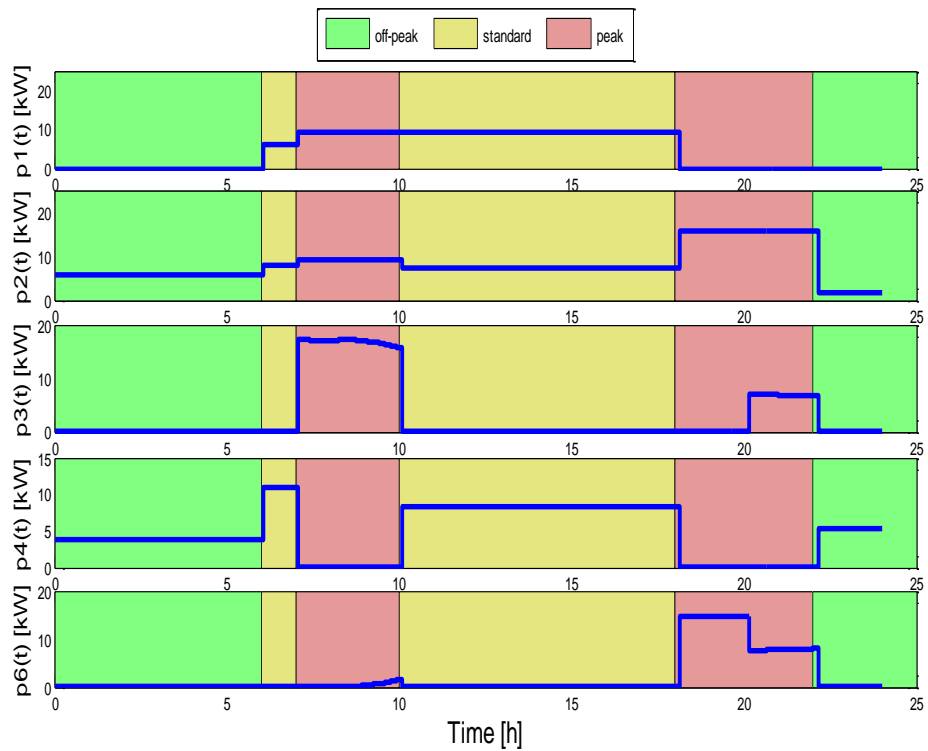

Figure 4-8: High demand season – weekend power flow

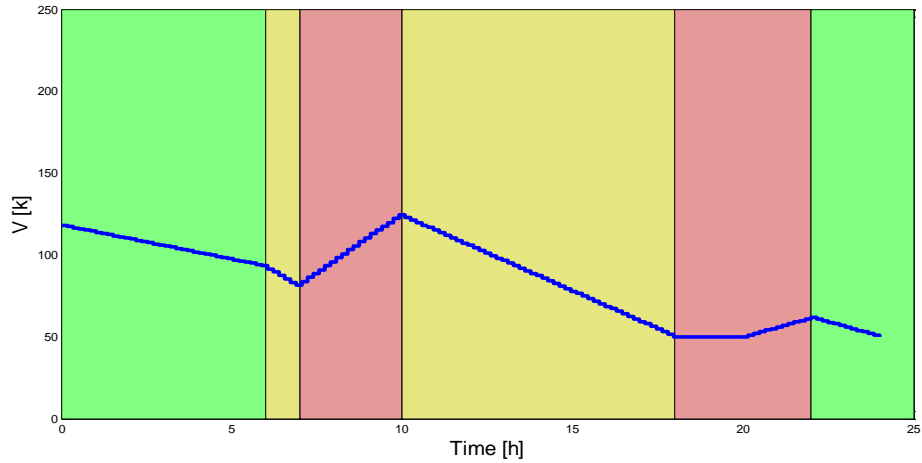

Figure 4-9: Reservoir dynamic (high demand season weekend)

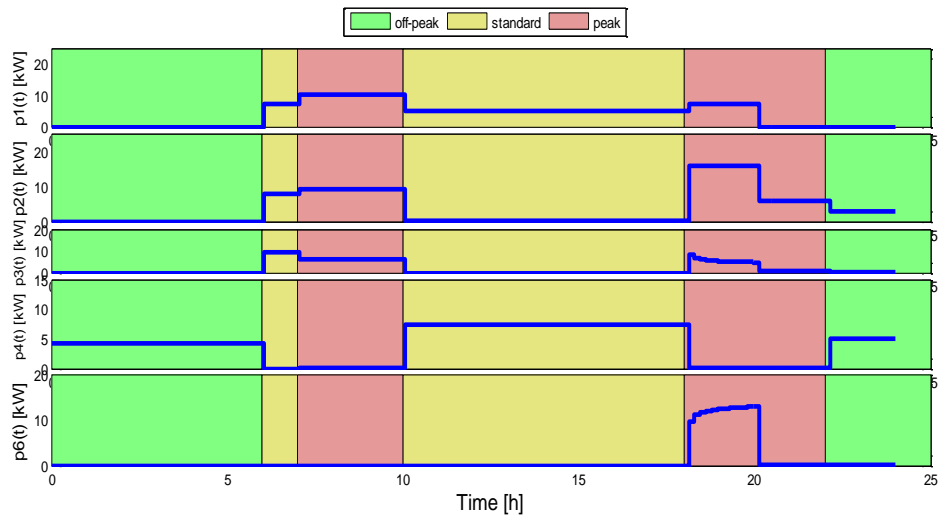

Figure 4-10: Low demand season weekday without an optimization.

Figure 4.10 describe a cases without the optimization applied to the model, P_6 which represents the energy flow to the grid, the sale can be only done at the night peak, and its affect also the working condition on the hydro pump to supply during the time the renewable energy source cannot supply the load.

Table 4-1: Sale of energy to the grid during the low demand season

	Weekend (Energy (kW/h))	Weekday Energy (kW/h)	Sale (Rand)
Peak Period (7h -9h)	20	20	41.8
Peak Period (18h- 20h)	35	35	41.8
Day Energy	55	55	

Table 4-1 indicates that the sale of energy registered during the morning peak is the same as that registered during the evening peak. Moreover, the price remains unchanged during the two peak periods. This demonstrates that the behaviour of people during the low demand season (summer) is more or less the same on weekends and weekdays. Less energy is thus consumed by the local load.

Table 4-2: Sale of energy to the grid during the high demand season

	Weekend (Energy (kW/h))	Week day Energy (kW/h)	Sale (Rand)
Peak Period (7h -9h)	0	20	80.15
Peak Period (18h- 20h)	35	35	125.95
Day Energy	35	55	

According to table 4-2, no sale of energy is registered on the grid for the morning peak period (winter) during a weekend day, only for the evening peak. This phenomenon can be explained by the fact that people mostly do not go to work during weekends; therefore, the energy generated by the renewable sources is insufficient to supply the local load and the grid during the morning peak. Hence, the behaviour of people and the seasons play an important role in the study model. The difference between sales during the morning and evening peaks is approximately 56.4 %. Given the advantage in price, more profit is made from the maximisation of sales during the winter period.

Table 4-3: The comparison between model with and without optimization.

	Low demand season weekday with an optimization (Week day energy)	Low demand season weekday without an optimization (Week day energy)
Peak Period (7h -9h)	20	0
Peak Period (18h- 20h)	35	12
Sale (Rand)	41.8	9.12

The two models have been presented in comparison from table 4-3, the first with an optimisation taken into consideration and the second without an optimization taken into account we can see the need to optimise the model, an optimisation model will improve the sale of the energy into the network during the peak period of the day, with the economical benefit for the sale compare to a model which has not been optimized.

4.6 SUMMARY

The optimisation model developed in this chapter aimed to achieve the maximisation of energy sales to the grid. The local load demand was mostly met during peak periods, and sometimes during the standard period as well when the network was under stress. The injection of energy into the grid from renewable energy sources assisted the utility to lower its losses and carbon dioxide emissions.

The results show the minimisation of pump use and the maximisation of the sale of energy. The model can benefit the utility by meeting its reserve constraints without overloading its generators. On the other hand, customers can adapt their energy consumption based on the TOU tariff scheme by shifting (reducing) their loads from peak periods when energy is more costly to off-peak and

standard periods at a cheaper energy rate. An advantage to the network is the benefit of reducing losses and alleviating stress during peak times, while renewable energy can yield profits for investments by carefully selecting the period of energy sales.

CHAPTER 5: A MODEL PREDICTIVE CONTROL STRATEGY FOR GRID-CONNECTED SOLAR-WIND SYSTEMS WITH PUMPED HYDRO STORAGE

5.1 INTRODUCTION

This chapter focuses on the model predictive control (MPC) applied to PV, PW, grid and the hydro pump configuration, while maximising the sale of energy to the grid, as well the maximisation of the use of renewable energy. The advantage this study offers in using MPC in open-loop control is that MPC will be able to respond to external disturbances or inaccurate supply sources. The MPC is able to adjust to changes in output when there are disturbances and the system will be re-optimised during its control horizon. This chapter demonstrates the advantage of a closed-loop optimal control model with renewable energy sources that will be connected to the grid with the aim to sell the energy to the grid during peak periods with the use of TOU. The introduction of MPC as a control tool in the system allows for the periodic re-optimisation characteristic that will demonstrate the stability of system control when external disturbances occur in the system. The re-optimisation is carried out during each sampling time as defined for the control horizon. Also, the re-optimisation is able to compensate for inaccuracies in the flow of energy into the grid. This study takes into consideration a 24-hour period of renewable energy source variations in the system when there are disturbances in the local load, as well the output of the renewable energy sources. The main comparison was drawn between the open-loop and control-loop systems, considering that a PV source will depend on the sun and a wind turbine (PW) on the wind. This work will demonstrate the advantage of the closed-loop system in real time compared to the open-loop control system, as a result of the periodic re-sampling. The open-loop system is more vulnerable to external disturbances and the system cannot be corrected without feedback. Multi-objective function optimisation is demonstrated by the sale of power to the grid, taking advantage of the TOU tariff and the use of the storage system; the power is created by the pump and the turbine.

5.2 PRINCIPLE OF OPERATION

The load is met by the renewable energy systems (PV and wind) and the hydro pump. The local load is represented by a clinic, houses and a grid. The grid and the renewable source are interconnected.

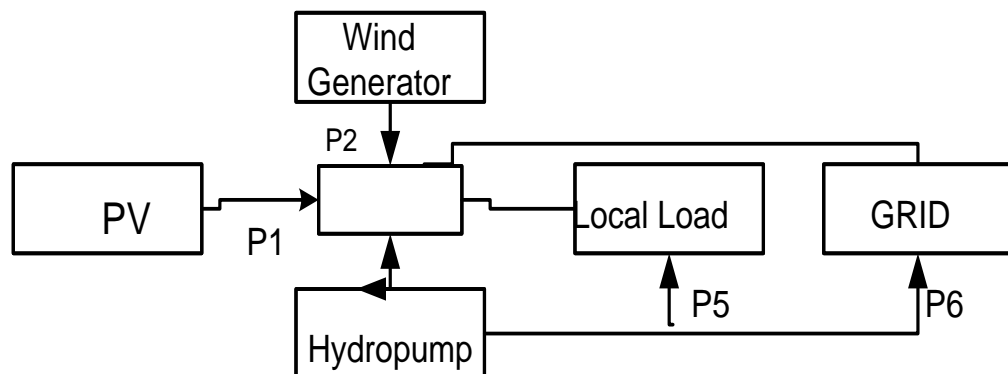

Figure 5-1: Schematic layout of the PV-wind-hydro pump

The conversion of renewable energy to mechanical energy or mechanical to electrical energy is used as energy storage in the system. In this chapter, the storage mitigates the intermittency of the renewable energy sources and helps to balance the fluctuating demand in order to maximise the sale of energy to the grid, benefiting from TOU tariff-based DSM. This is achieved by maximising the sale of hybrid energy to the grid. In peak periods, for instance, where the grid energy cost is very high, the hybrid energy plant operator can optimally inject more power into the grid in order to maximise the benefit (sales). However, the aim is to influence customers to shift their loads from peak periods to off-peak and standard periods.

In this manner, both the power utility and the customers would benefit. On the one hand, the generators of the utility will not be overloaded as a result of meeting their reserve constraints. On the other hand, customers could adapt their energy consumption based on TOU tariffs by shifting (reducing) their loads during peak periods when the energy is costly to off-peak and standard periods at a cheaper rate. The principle of operation of the renewable energy source is presented as follows: The water is pumped by the motor, as illustrated in Figure (5-1) by (P_3), from the lower reservoir or river to the upper reservoir using the excess of the energy supply by the main bus, and is produced by PV (P_1) and wind (P_2). The stored water is allowed to flow into the lower reservoir in order to turn the turbine and generate the energy (P_4) back to the main bus to be used during the peak period and to enable sales of energy to the grid. In this manner, a reliable 24-hour source of energy is guaranteed.

5.3 SUB-MODELS

The models of the PV, PW as well the hydro pump have been discussed in chapters 3 and 4.

5.4 OPEN-LOOP CONTROL

The PV, PW and the pumping system are modelled as the variable power sources that are controlled during the 24 hours defined as the control horizon. The energy flowing into the grid is optimised during the peak hours to decrease the stress in the network as well as to take advantage of the TOU to make a profit. The multi-objective is to maximise the sale of energy to the grid by taking advantage of the TOU electricity tariff, which will also contribute to the proposed model of control strategies. The TOU tariff is an important parameter in this model. The maximisation of energy sales will be achieved by selling more energy to the national grid during the peak period where the energy cost is higher than during off-peak and standard periods. The classification of the TOU input parameters will be off-peak, standard and peak. This will also differ during the low and high demand seasons. The objective of the function is given by the following expression:

$$- \max \sum_{i=1}^k P_6(k)P(k) \quad (5.1)$$

The second objective to minimise the energy supplied by the main source to the pump (P_3) is expressed by:

$$\min \sum_{i=1}^k P_3(k). \quad (5.2)$$

The combinations of the two objective functions give the multi-objective function to optimise, which is expressed by:

$$-\max \sum_{i=1}^k p_6(k)p(k) + \min \sum_{i=1}^k p_3(k). \quad (5.3)$$

The constraints of this optimal control problem are listed as follows:

1. Equation (5.4) implies that the power supplied by the PV, PW and the hydro pumping system are equal to the total power and the Kirchhoff law is applied to determine the total power in the main bus.

$$P_1(k) + P_2(k) + P_4(k) = P_3(k) + P_5(k) + P_6(k) \quad (5.4)$$

2. Equation (5.5) ensures that the power supplied by the PV, PW and the hydro pump at any hour of the day is greater than or equal to the local load and the load to be supplied to the grid during the peak period.

$$P_1(k) + P_2(k) + P_4(k) \geq P_5(k) + P_6(k) \quad (5.5)$$

3. Equation (5.6) ensures that the power supplied by the PV, PW and the hydro pump directly to the local load or the grid is greater than or equal to zero.

$$P_1(k) \geq 0; P_2(k) \geq 0; P_4(k) \geq 0 \quad (5.6)$$

4. Each energy source i is constrained by minimum and maximum values as specified in equation (5.7)

$$P_i^{\min} \leq P_i(k) \leq P_i^{\max} \quad (5.7)$$

5. Equation (5.8) ensures that the water in the upper reservoir will not be less than the minimum value or higher than the maximum value.

$$V^{\min} \leq V(0) + \Delta t \cdot c_p \sum_{i=1}^k P_3(k) - \Delta t \cdot \frac{1}{c_t} \sum_{i=1}^k P_4(k) \leq V^{\max} \quad (5.8)$$

For all instances of $k=1, \dots, N$ is the sampling time. $P_1(k), P_2(k)$ and $P_4(k)$ are the control variables representing the energy flow from the PV, PW and the energy supplied by the PH system to the load at any time (k) respectively and $P_3(k), P_5(k)$ and (P_6) represent the energy flow to the pump, the energy flow to the local load, and the energy flow to the grid respectively.

5.5 MODEL PREDICTIVE CONTROL CONFIGURATION

Model predictive control can be defined as closed-loop control of the plant, which aims to predict the outputs. The basic understating of the MPC is that of open-loop control, which will be solved within the control horizon at each sampling time where the state of the plant is re-sampled and the process of optimisation is calculated by iteration [224]. The process is calculated each time there is a flow of energy to the grid and flow of energy from the storage system to the load. The control system can be assessed and the process can move to the next iteration based on the update

information such that the unpredicted situation can be addressed. This is performed for each sampling time.

The re-sampling assists the system to become stable during disturbances. In this case, with the dependency of the PV or PW on weather conditions, the closed-loop system provides stability of energy flow into the system. Figure 5-2 depicts the basic structure of the MPC approach.

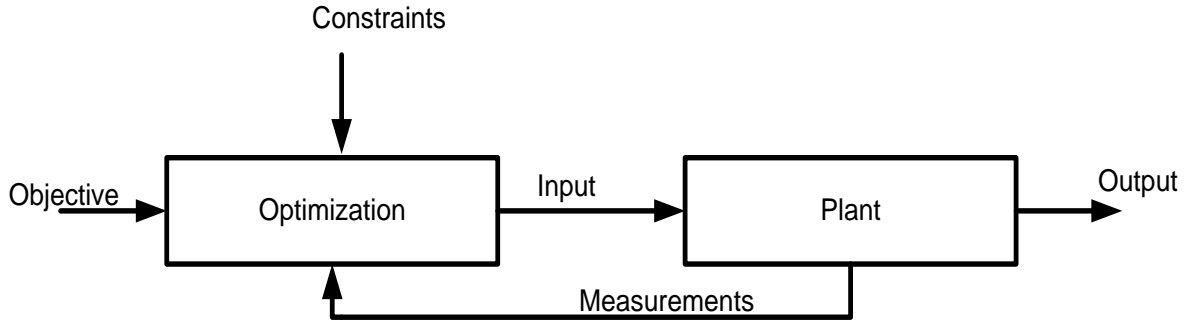

Figure 5-2: The MPC structure [225]

5.5.1 Discrete linear model of the MPC

The MPC linear model for a given configuration can define as:

$$x(k+1) = Ax(k) + Bu(k) \quad (5.9)$$

$$y(k) = Cx(k) + Du(k), \quad (5.10)$$

Where A system matrix and its dimension is $n \times n$, B control matrix and its dimension $m \times n$ and c is the output matrix and its dimension is $n \times p$, D is feed forward matrix and its dimension is $m \times p$, $x(k), u(k)$ and $y(k)$ are state matrices, input matrix and output matrix, respectively. In the application of MPC the feed-forward matrix is null. Therefore the equation (5.9) and (5.10) can be rewritten as follow [224]:

$$x(k+1) = Ax(k) + Bu(k) \quad (5.11)$$

$$y(k) = Cx(k) \quad (5.12)$$

The performance index or the objective function of the MPC is described by the equation (5.13)

$$J = \sum_{i=1+m}^{k+m} (y(k+i-1|k) - r(k+i-1))^2$$

$$J = (R - Y)^T (R - Y) \quad (5.13)$$

And this subject to the following constraint:

$$Mu(k) \leq \gamma \quad (5.14)$$

where , $Y = [y(k+1|k) \ y(k+2|k) \dots \dots \dots y(k+N_p|k)]^T$ and $y(k+i|k)$ represents the initial value of y at $i(i=1, \dots, N_p)$ from the sampling time. $R(k) = [r(k+1) \ r(k+2) \dots \dots \dots r(k+N_p|k)]$ is the predicated reference value for Y , N_p represents the 24 hours taken as the control horizon, which is equal to the predicted horizon selected and predicted states can be calculated by:

$$\begin{aligned}
 x(k+1|k) &= Ax(k) + Bu(k) \\
 x(k+2|k) &= Ax(k+1|k) + Bu(k+1) \\
 &= A^2x(k) + Bu(k) + Bu(k+1) \\
 &\vdots \\
 &\vdots \\
 x(k+N_p|k) &= A^{N_p}x(k) + A^{N_p-1} + \dots \dots \dots + A^{N_p-N_c}Bu(k+N_c-1) \\
 Y(k) &= [c, c, \dots, c]X(k) = Fx(k) + \phi U
 \end{aligned} \tag{5.15}$$

where $X(k) = [x^T(k), x^T(k+1|k), \dots, x^T(k+N_p-1|k)]^T$,

$U(k) = [u^T(k), u^T(k+1|k), \dots, u^T(k+N_p-1|k)]^T$, and

$$F = \begin{bmatrix} CA \\ CA^2 \\ \vdots \\ CA^{N_p} \end{bmatrix}, \phi = \begin{bmatrix} CB & 0 & \dots & 0 \\ CAB & CB & & 0 \\ \vdots & & \ddots & \vdots \\ CA^{N_p-1} & CA^{N_p-2} & \dots & CA^{N_p-N}B \end{bmatrix} \tag{5.16}$$

The predicted output, equation (5.13), can be substituted into (5.11), therefore minimising the performance index will be equivalent to minimising the equation (5.15) as:

$$J = U^T E U + F U,$$

where

$$E = \phi^T \phi, H = (Fx(k) - R(k))^T \phi \tag{5.17}$$

The use of numerical tools is recommended to solve the optimization problem below, by considering the constraint given in equation (5.12) as follows:

$$U = \arg \min U^T E U + F U \tag{5.18}$$

The receding of control horizontal is the base of implementing MPC. This described by the equation (5.17), where I is the identity matrix with proper dimension, and the equation will be derived as

$$u(k) = [I, 0, \dots, 0]U. \tag{5.19}$$

The model predictive control is based on the control series of input system which is computed by using optimal control techniques, which implements only the first dimension of input element. The closed loop of this system is used to minimise the cost function [226].

The application model of the MPC is given by equations (5.9) and (5.10), the inputs of the model are defined by the energy flow from the PV ($p_1(k)$), The energy flow from the PW $p_2(k)$, the energy supply by $p_3(k)$, the energy supplied by the turbine $p_4(k)$, $P_L(k)$ is define as the load demands at kth sampling time, and the outputs can be define by $p_6(k) + p_5(k) - P_L(k) = p_1(k) + p_2(k) + p_4(k) - p_3(k)$ The transformation process will be analysed by the dynamic of the reservoir and the input variable into the system.

With $x_m(k) = v(k)$ and the input is $u(k) = [p_1(k), p_2(k), p_3(k), p_4(k)]^T$, the dynamic model of the reservoir can be derived from equation (5.14)

$$x_m(k) = x_m(k-1) + b_m u(k-1) \quad (5.20)$$

Where the value of $b_m = [0, 0, \alpha, -\alpha]$, to analyse the predicted value in the control horizon, of 24 hours can be calculated as:

$$y_m(k) = p_5(k) + p_6(k) - p_3(k) = p_1(k) + p_2(k) + p_4(k) \quad (5.21)$$

where:

$$y_m(k) = c_m x_m(k) + d_m u(k) \quad (5.22)$$

With $c_m = 0$ and d_m represented by [1, 1, 1, 1] the definition the y_m will be to maximise the sale of energy to the grid.

The auxiliary expression of the output is $y_a(k) = p_5(k) + p_6(k) + p_3(k) = c_a x_m + d_a u(k)$, the value of $c_a = 0$ and $d_a = [1, 1, 0]$.

The augmented system states $x(k) = [V(k), x_m(k-1), y_m(k-1), y_a(k-1)]^T$ and the output vector will be $y(k) = [y_m(k-1), y_b(k-1), y_a(k-1)]^T$ the matrix format of the model can be derived from the linear state space in equation (5.11) and (5.12)

$$A = \begin{bmatrix} (1+T_A) & 0 & 0 \\ 0 & (1+T_A) & 0 \\ 0 & 0 & 1 \end{bmatrix} \quad B = \begin{bmatrix} T & T & 0 & T \\ T & T & 0 & T \\ 0 & 0 & \Delta t c_p & -\frac{\Delta t}{c_t} \end{bmatrix} \quad c = \begin{bmatrix} 1 & 0 & 0 \\ 0 & 1 & 0 \end{bmatrix} \quad (5.23)$$

The combination of the three matrix A, B and C are represented by equation (5.23), and can be add to the linear state – space system (5.11) and (5.12), in this condition the plant can be designed by the optimisation of the MPC.

The objective functions are divided into two:

- The first objective to maximise the sale of the energy into the grid, it can be define as:

$$-\max J_1(k) = -\max \sum_k^{k+N_p} p_6(k) = -\max \sum_k^{k+N_p} (P_L(k) - y_m(k))^2 \quad (5.24)$$

- To minimise the use of the motor, and it can be define as:

$$\min J_2(k) = \min \sum_k^{k+N_p} (P_1(k) + P_2(k) - y_a(k))^2 \quad (5.25)$$

Applying equation (5.11) into (5.22) and (5.23), the objective function can be written as:

$$\min J(k) = -\max(J_1(k)) + \min(J_2(k)) \quad (5.26)$$

5.5.2 Constraints

1. The power generated by the PV and the wind generator are superior to the power used by the local load $p_6(k)$ when the loss are taken into consideration.

$$PV \geq p_6, \quad PW \geq P_6 \quad (5.27)$$

2. The reservoir dynamic is subject to its minimum and maximum value.

$$V^{\min} \leq V_m(k) \leq V^{\max} \quad (5.28)$$

Equations (5.25) and (5.26) can written under a matrix format

$$M_1 u(k) \leq \gamma_1 \quad (5.29)$$

where :

$$M_1 = \begin{bmatrix} -1 & 0 & 0 & 0 \\ 0 & -1 & 0 & 0 \\ 0 & 0 & -1 & 0 \\ 0 & 0 & 0 & -1 \\ 1 & 1 & 0 & 1 \\ 1 & 1 & 0 & 1 \\ 1 & 0 & 0 & 0 \\ 0 & 1 & 0 & 0 \\ 1 & 0 & 0 & 0 \\ 0 & 1 & 0 & 0 \\ 0 & 0 & 0 & 1 \\ 0 & 0 & -1 & 1 \end{bmatrix} \quad \gamma_1 = \begin{bmatrix} 0 \\ 0 \\ 0 \\ 0 \\ p_5(k) \\ p_6(k) \\ p_V(k) \\ p_w(k) \\ p_1^{\max} \\ p_2^{\max} \\ p_3^{\max} \\ p_4^{\max} \end{bmatrix} \quad (5.30)$$

The equation (5.28) can rewritten using the control series

$$\overline{M}_1 U(k) \leq \overline{\gamma}_1 \quad (5.31)$$

The equation (5.14) can be expressed as matrix format, where

$$\overline{M}_1 = \begin{bmatrix} M_1 & & & \\ & \ddots & & \\ & & M_1 & \end{bmatrix}, \gamma_1 = \begin{bmatrix} \gamma_1 \\ \vdots \\ \gamma_1 \end{bmatrix} \quad (5.32)$$

The reservoir dynamic can be written as

$$X_m(k) = x_m(k)[1, 1, \dots, 1]^T + V_m U(k) \quad (5.33)$$

With $X_m(k)$ represents the state vector, and composed by the predicted value of x_m at each sampling time k , and the input matrix V_m of the hydro pump is given as follows:

$$V_1 = \begin{bmatrix} V_m & 0 & \cdots & 0 \\ V_m & V_m & \ddots & \vdots \\ \vdots & & \ddots & 0 \\ V_m & V_m & \cdots & V_m \end{bmatrix} \quad (5.34)$$

Taking into consideration the reservoir dynamic equation (5.32) can be written in a compact form as:

$$\overline{M}_2 U(k) \leq \overline{\gamma}_2 \quad (5.35)$$

Where \overline{M}_2 and $\overline{\gamma}_2$, are constraint matrix of the reservoir, which can expressed as:

$$\overline{M}_2 = \begin{bmatrix} -V_m \\ V_m \end{bmatrix}, \overline{\gamma}_2 = \begin{bmatrix} (x_m(k) - V^{\min})[1, 1, \dots, 1]^T \\ (V^{\max} - x_m(k))[1, 1, \dots, 1]^T \end{bmatrix} \quad (5.36)$$

The system will be summarising with reservoir constraint matrix in combination to the equation (5.29), which will derived as:

$$M = \begin{bmatrix} \overline{M}_1^T & \overline{M}_2^T \end{bmatrix}^T, \gamma = \begin{bmatrix} \gamma_1^T & \gamma_2^T \end{bmatrix}^T \quad (5.37)$$

5.5.3 Implementation of the main algorithm

The following step are summarised to develop the model by using the MPC gains:

1. State space definition and the initial condition of PV, PW, Hydro pump and grid;
2. Determine the MPC gains to define E and H , which are given by equation (5.17);

Determine the optimisation solution by applying the objective function and its constraints, which are given by equations (5.13) and (5.37) respectively:

3. Determine and analyse the receding control given by equation (5.17);
4. Update the new configuration of the system by setting $k = k + 1$ with the control $u(k)$; and
5. All the 5 steps must be repeated until k reaches the predicted value.

5.6 MODEL PARAMETERS

The power demands of different consumers will vary according to their need. The grid cannot have a constant load profile, since it varies from time to time and depends on the type of load, which can be classified as domestic, industrial or commercial. The variation of the load profile exerts an impact on the flow of energy into the grid, which could be related to the price of the electricity. This has become a very important tool for optimal energy control, which has been referred to as the TOU tariff. The Eskom *Miniflex* tariff is used for the high demand and low demand seasons. The study differentiated the load profiles of weekdays and weekends.

Tariff for the high demand season:

$$p(t) = \begin{cases} p_o = 0.37376 \text{ R/kWh} & \text{if } t \in [0,6] \cup [22,24] \\ p_s = 0.6953 \text{ R/kWh} & \text{if } t \in [6,7] \cup [10,18] \\ p_p = 2.2952 \text{ R/kWh} & \text{if } t \in [7,10] \cup [18,22] \end{cases} \quad (5.38)$$

Tariff for the low demand season:

$$p(t) = \begin{cases} p_o = 0.3358 \text{ R/kWh} & \text{if } t \in [0,6] \cup [22,24] \\ p_s = 0.5 \text{ R/kWh} & \text{if } t \in [6,7] \cup [10,18] \\ p_p = 0.76 \text{ R/kWh} & \text{if } t \in [7,10] \cup [18,22] \end{cases} \quad (5.39)$$

where R is the South African currency, rand, and t is the time of any day in hours (from 0 to 24).

5.6.1 Power sources

Renewable energy sources are solar power, wind power and the PH system. The control variables include $p_1(k)$, $p_2(k)$, $p_3(k)$ and $p_4(k)$, expressed in kW. Solar power and wind power are determined by their profile, which varies during the 24-hour period between $[t_0, t_f]$ taken in the model as the control horizon. The maximum and minimum values are divided by N sample intervals into the sampling time Δt in the control horizon. A 25 kW PV generator produces about 11 to 15 kW in the morning and 9 to 20 kW in the afternoon, and 20 kW wind power produces 8 to 12 kW and 10 to 15 kW in the morning and afternoon peak periods respectively.

5.6.2 Grid power and local load

Since the local demands are represented by the clinic and family houses, the profiles will differ; that is, there will be two kinds of load: a commercial load and a domestic load. The grid is supplied so as to maximise sales when the local demand is met at different times of the day in the control horizon. The benefit to the utility is that the network can operate at its optimum performance by reducing losses in the system.

5.7 RESULTS

The case study data refer to the weekday flows during a low demand season, where the open-loop control application is applied without any disturbances. The results of the open-loop control are displayed in Figure (5-3). The energy flows for the entire 24-hour period. At night and in the early morning the load demand is met by the PHS system and sales to the grid are maximised during peak periods. The constraints in (5.4) and (5.8) are met by ensuring that the power supplied by the PV, PW and the hydro pump at any hour of the day is equal to the local load and the load to be supplied to the grid during the peak period; it must be equal to or greater than the combined loads.

Generally, the pump runs ($P_3(k)$) during peak hours and supplies the load mostly at night when there is no power from the PV and PW. At night and in the early hours of the morning the load is met by the PW and the PH system. The PH system will turn off when the PV and PW produce sufficient power to meet the loads and to pump the water into the upper reservoir.

The PV and PW output continues to increase until they produce more energy than the load and are able to pump the water to the upper reservoir, from the moment the turbine switches off until the PV and PW cannot produce enough power to meet the local load as well as supply power to the grid.

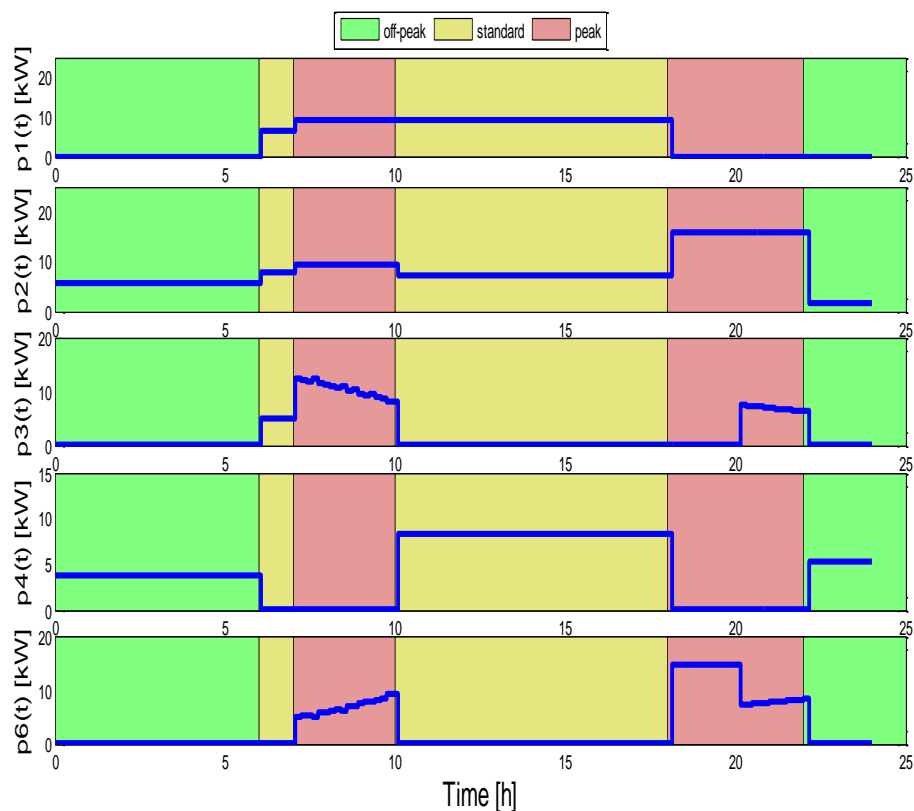

Figure 5-3: Simulation of open control without disturbances

The dynamics of the reservoir are illustrated in Figure (5-4), the turbine running time and the amount of power supplied by the PHs depends on the water stored in the upper reservoir and the

amount of power produced by the renewable energy sources. It is evident that the PHs runs for more hours and generates more power when the outputs from the renewable energy sources are low.

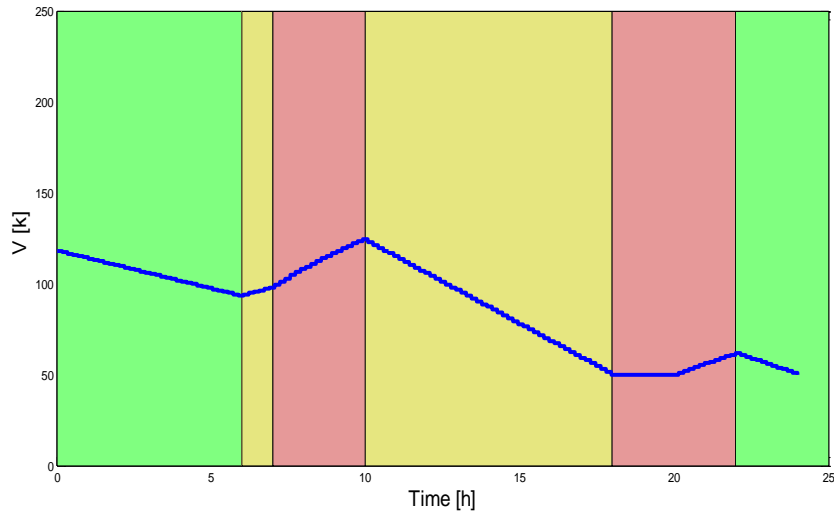

Figure 5-4: Open-loop simulation of the reservoir dynamic without disturbances

In the second scenario, the MPC is applied to the system without any disturbances. The closed-loop system results appear in Figure (5-5). It is evident that the use of the different energy sources in the closed-loop system can be planned to satisfy the load demand and the sale of energy in the system. Referring to Figure (5-5), the optimal peak of the first sale occurs during the morning and the second peak at night. In the case of the PV and PW, there is sufficient energy to supply the local load; thus the generator (P_4) can meet the load demand.

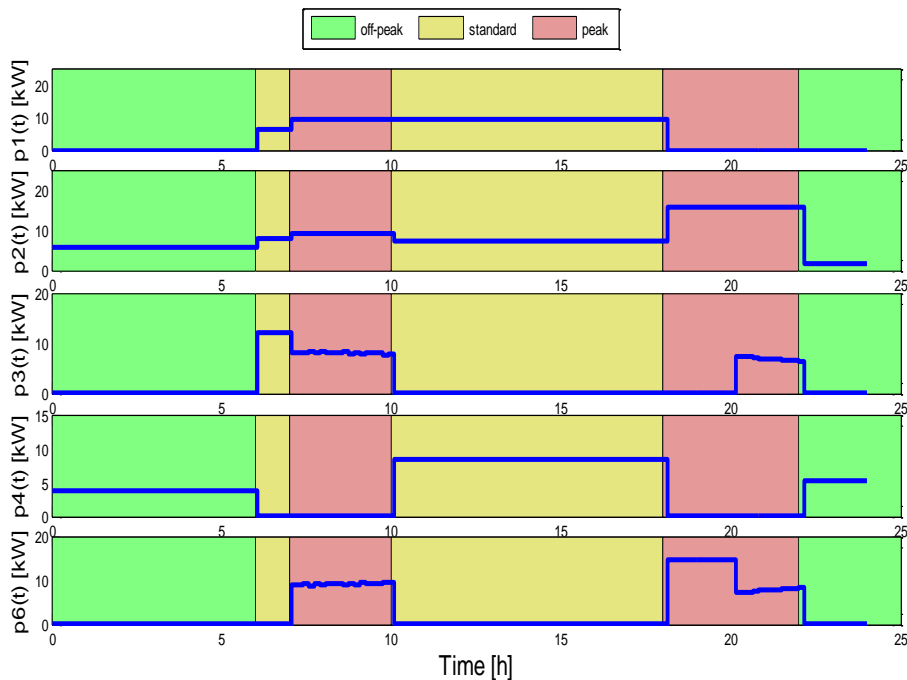

Figure 5-5: Simulation of closed-loop control without disturbances

A comparison of the performance of the open-loop control system and the closed-loop control system indicates that they are similar when there are no disturbances in the response of the optimisation model, as is evident in Figures (5-3) and (5-5). The optimisation of the energy (P_6) during the morning peak is similar to that of the afternoon peak.

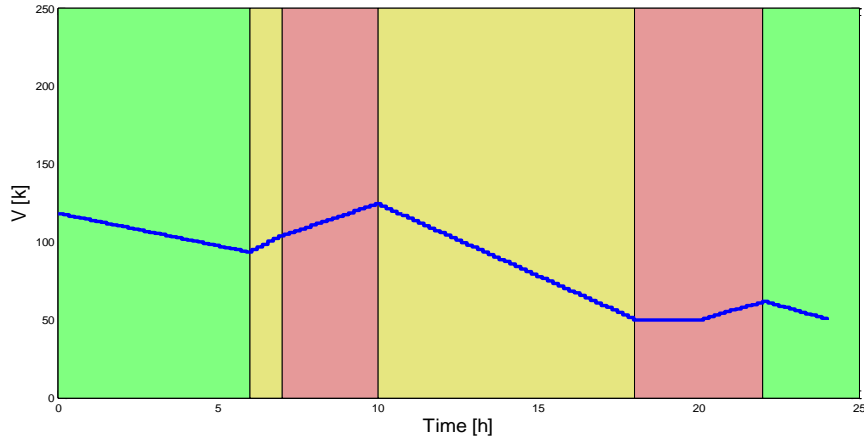

Figure 5-6: Closed-loop control simulation of the reservoir dynamic without disturbances

When the reservoir dynamic of the two systems is compared, as illustrated in Figures (5-4) and (5-6), it appears that the change of the water in the open-loop system and the model predictive control system is identical.

The third scenario introduces disturbances in open-loop control, which result from weather conditions. The PV, which depends on the sun, produces only 10% of the hybrid energy system, whereas the PW supply maintains its normal condition and the local demand is increased to 30% greater than its expectation. The result is depicted in Figure (5-7).

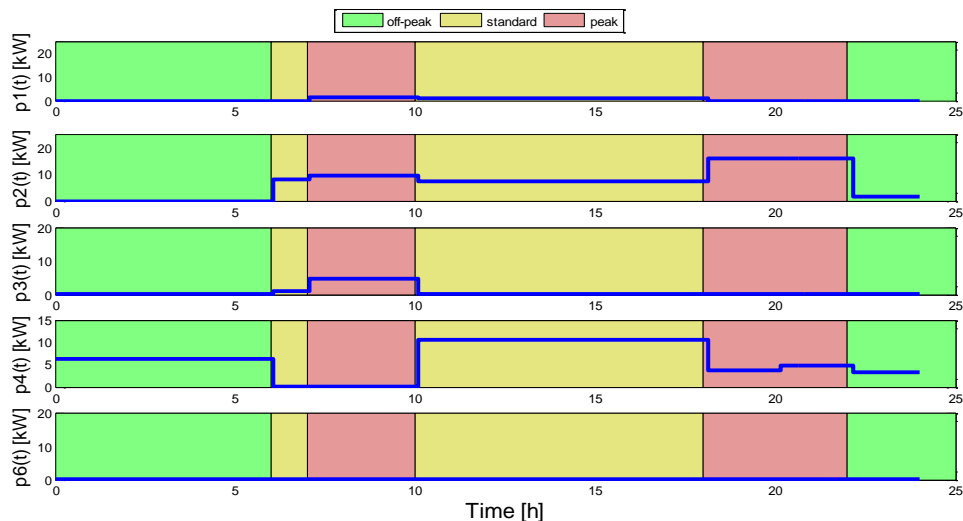

Figure 5-7: Simulation of open-loop control with disturbances

It is evident that no sale of energy (P_6) is registered during the peak morning periods and the peak night periods. The energy supplied by the turbine (P_4) is used to meet only the local load between 10:00 and 6:00 the following day. The pump (P_3) cannot run while the turbine (P_4) is supplying power to the hybrid system.

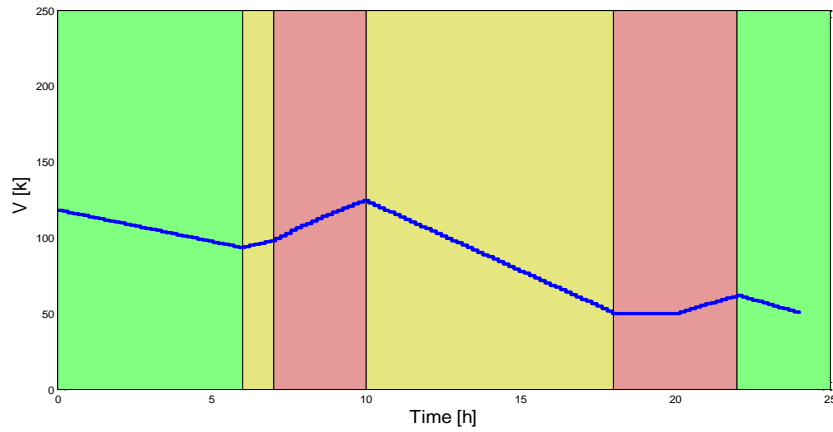

Figure 5-8: Open-loop simulation of the reservoir dynamic with disturbances

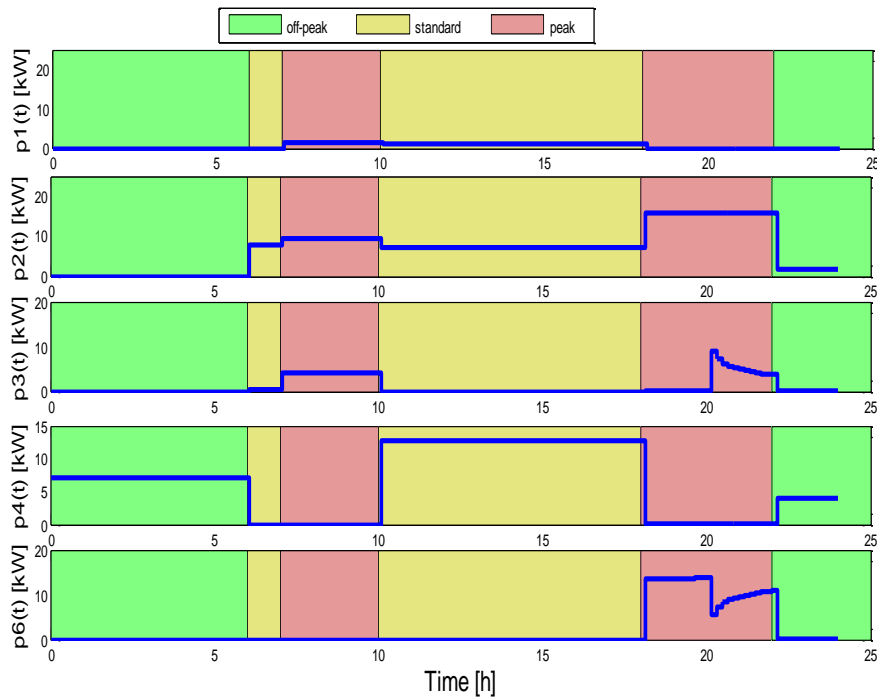

Figure 5-9: Closed-loop control simulation of the reservoir dynamic with disturbances

With closed-loop control the sale of energy (P_6) was registered during the afternoon peak period and the energy supplied by the turbine (P_3) was used in the afternoon to supply the local load. (P_3) can run the pump between the two peaks, and during the standard and the off-peak time the

pump can stop as well as allow (P_4) to be operational in order to meet the load demand. During an increase in the load as well as disturbances in the PV output, a correction was made to meet the local load as well as maximise the energy to the grid demand by increasing the level of the water in the reservoir to keep the storage system running for longer to compensate for the deficit created by the renewable energy sources. This is illustrated in Figure (5-10).

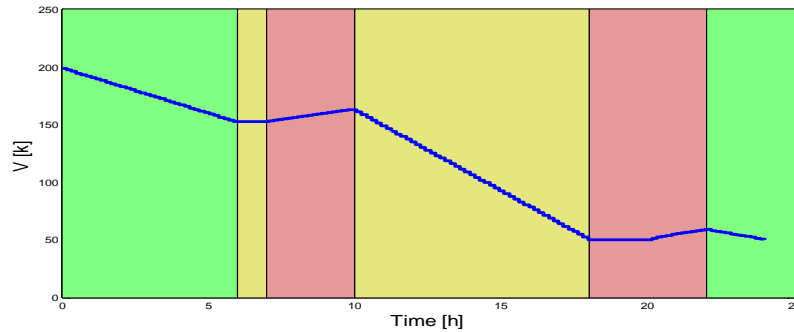

Figure 5-10: Closed-loop simulation of reservoir dynamic with disturbances

When comparing the performance of the open-loop control and closed-loop control systems with the disturbances shown in Figures (5-7) and (5-9), it is evident that the performance of the closed-loop system is better with respect to the disturbances. It demonstrates the robustness of a closed-loop control system to predict the future state because of its feedback from the plant to the controller, as shown in Figure (5-2). On the other hand, open-loop control is unable to influence control during disturbances, where (P_6) cannot be optimised during peak hours and only (P_4) will be able to supply the entire half day to cover the insufficient amount of energy generated from the PV.

Table 5-1: Sale of energy to grid

	Open-loop control system without disturbances	Closed-loop control without disturbances	Open-loop control with disturbances	Closed-loop control with disturbances
Morning Peak (R/kWh)	47.7401	47.8804	0	0
Night Peak (R/kWh)	97.3164	97.3164	5.050	93.4882
Total Energy	145.056	145.1968	5.050	93.4882

Table 5-1 displays the sale of electricity during the two main peak periods. It is evident that the amount of energy that has been sold to the grid is the same in the closed-loop control system and the open-loop control system when there are no disturbances,

However, when disturbances are introduced during the operation of open-loop control, a small amount of energy flows to the grid. Only during the period in which closed-loop control is applied

in the system is there a significant flow of energy to the grid and the sale of energy to the grid is optimised during the second peak period.

Table 5-2: Performance of closed-loop control

	Open-loop control without disturbances Error (%)	Open-loop control with disturbances Error (%)	Closed-loop with disturbances Error (%)
Morning peak	0.292	100	100
Night peak	0	94.810	3.933
Total	0.0922	96.5214	35.612

Closed-loop control without disturbances is applied to the model as reference in order to compare the performance of closed-loop control with open-loop control with or without disturbances and closed-loop control with disturbances. The result, shown in table 5-2, confirms the conclusion drawn from Figures (5-3), (5-5), (5-7), (5-9) and table (5-1). It can be seen that the introduction of closed-loop control to the system has an advantage over open-loop control during the period when disturbances are experienced.

5.8 SUMMARY

In this chapter, closed-loop control was applied to the PV and PW, with the storage system connected to the grid as well as the local load. A comparison of the performance of open-loop control and closed-loop systems with and without disturbances for a 24-hour period was adopted as a control horizon. Closed-loop control showed better performance owing to its robustness during the disturbances. The results demonstrate that the implementation of closed-loop control in the hybrid system, which PV and PW, is dependent on weather conditions.

CHAPTER 6: OPTIMISATION AND SALE OF ENERGY TO THE GRID WITH SPECIAL EMPHASIS ON FREQUENCY CONTROL

6.1 INTRODUCTION

In This chapter an objective is developed to maximise the sale of the energy to the grid. The frequency is been analysed where the speed of the generator is taken as the state variable, because of the its dynamic, the frequency vary in any time of the control horizon when the load increase or decrease, this situation affect the network , which mean the frequency is dependent to the power flow in different load buses. The hydro pump is introduced as a storage system to replace the batteries. The integration of the renewable energy sources to grid will improve management and the control for the entire system. The effective energy management and control of the hybrid plant is of great importance to ensure economically feasible system.

Another important function of conventional power plants for frequency control provided so-called instantaneous power reserve. Any imbalance between the generation and power demand will reflect to the output power or so called the electrical power, the effects can be seen through the frequency as the voltage. The large inertia of the rotating generator set works as buffer storage, any usage leading to the mentioned change in rotational speed and thus in system frequency. The larger the synchronised inertia in the system, the slower the change of frequency [227].

The combination of a renewable energy source with the conventional source will have a significant impact on network and the system frequency behaviour. In order to maintain the system frequency stability in a network with an increasing share of the renewable energy source, wind turbines will have to take on more and more tasks of conventional power plants related to frequency control and network stability. In most cases the renewable energy sources plants are already required to provide in most cases the power reserves.

6.2 MODEL OF NETWORK DYNAMICS

Instantaneous power reserves refer to the physical stabilising effect of all connected synchronous generators due to their inertia in the event of a generation drop in the network; the instantaneous reserves balance the power because of this stabilising and passive effect. Their electrical power, which is represented in this model as $p_8(k)$, increases rapidly, which provokes an electromechanical unbalance in the generator according to:

$$p_9(k) - p_8(k) = \omega \frac{d^2 S}{dt} \quad (6.1)$$

where mechanical power is represented by $p_9(k)$, ω : is the mechanical speed generator and equation (6.1) represents the expression of the dynamic acceleration of the rotor. The derivation of equation (6.1) will be determined by its first derivative, which will be expressed as the speed of the motor and defined by equation (6.2):

$$\frac{\omega ds}{dt} = p_9(k) - p_8(k) \quad (6.2)$$

where expression $\frac{\omega ds}{dt}$ is the speed of the rotor,

6.2.1 Sub-models

The representation of this system has been derived from Figure 4-1. It is composed of a conventional power plant and two power generators (PV array and wind turbine). The local loads are represented by a clinic and houses, and a grid that is an interconnection between the grid and the renewable source. The maximisation of energy sales is achieved by selling more energy to the national grid during peak periods when the energy costs are higher than during off-peak and standard periods. The model takes care of the network dynamic during the sale. The mathematic model of different sources will be:

$$P_9(k) - P_8(k) + P_1(k) + P_2(k) - P_3(k) + P_4(k) = P_{source} \quad (6.3)$$

where the principle of the operation of different sources entails the following: The water is pumped by the motor (P_3) as depicted in Figure (4-1) from the lower reservoir or river to the upper reservoir, and by using the excess energy supplied by the main bus, PV (P_1) and wind (P_2) are produced. The stored water is then allowed to flow to the lower reservoir to turn the turbine and generate energy (P_9). (P_8) is the electrical power supplied by the conventional source. The PV, PW and hydro pump models are described in detail in the previous chapter.

6.3 NETWORK UNIT MODEL

Turbine-generator units operating in a power system contain stored kinetic energy because of their rotating masses. If there is an increase in the load, stored kinetic energy is released to initially supply the increased load demand. The electrical torque (T_e) of each turbine-generating unit will also increase to supply the load increase; at the same time the mechanical torque (T_m) of the turbine initially remains constant. This can be explain by Newton's second law equation [228].

$$J_\alpha = T_m - T_e. \quad (6.4)$$

At this moment there will be negative acceleration, which means that each turbine generator decelerates and the speed of the rotor drops as kinetic energy is released to supply the load increase. The electrical frequency of each generator, which is proportional to rotor speed for synchronous machines, decreases. Based on the above statement, the conclusion is that either rotor speed or generator frequency indicates a balance or imbalance of generator T_e and turbine T_m . In the time the speed or frequency decreases, T_e is greater than T_m (neglecting generator losses). In the same way, if speed or frequency is increasing, T_e is less than T_m [227-228]. Generator frequency is consequently an appropriate control signal for governing the mechanical output power of the turbine. The variation in speed of the rotor can be defined by:

$$S(k+1) - S(k) = \Delta t \left(\frac{P_9(k)}{\omega} - \frac{P_8(k)}{\omega} \right). \quad (6.5)$$

The following general expression derived from equation (6.5) applies to the change of the speed of the rotor, which means when there is a variation in the load into in the network, it will be reflected in the variation of the speed or the frequency.

$$S(k+1) = S(0) + \Delta t \sum_{i=1}^k \frac{P_9(k)}{\omega} - \Delta t \sum_{i=1}^k \frac{P_8(k)}{\omega} \quad (6.6)$$

where $S(0)$ is considered the initial speed of the rotor, $\Delta t \sum_{i=1}^k \frac{P_9(k)}{\omega}$ represents the mechanical power at any time, and $\Delta t \sum_{i=1}^k \frac{P_8(k)}{\omega}$ is the electrical power at any time.

In the time of the increase of frequency in the grid, the renewable energy sources reduce their output by a margin against the power output immediately prior to the grid frequency rise. The network frequency increase will normally result in a period of constant output, unless the available power suddenly drops.

The activation of secondary reserves restores the normal operating of its frequency levels and also the deactivation of primary reserves. The secondary reserves are operated until they are fully replaced by tertiary reserves, which can be represented by equation (6.7):

$$f^{\min} \leq f(k) \leq f^{\max} \quad (6.7)$$

where f^{\min} and f^{\max} are the minimum and maximum expected instantaneous frequency after a reference incident assuming predefined system conditions.

6.4 OPTIMISATION MODEL

The TOU tariff scheme has been employed in the mining sector to facilitate better system performance and to save on the cost of electricity. In [21] and [22] the efficiency of applying a conveyor belt has been emphasised in the application of TOU to show that a great saving on energy costs is achievable. To maximise the energy supply to the grid with the use of renewable energy sources, optimal control must be introduced and the energy cost must be taken as a typical indicator to measure the sales performance of the grid. The total electricity cost within a time period is the related energy cost within the time period, which can be expressed as:

$$E_C = \int_{t_0}^{t_f} p_6(k) p(k) dk \quad (6.8)$$

where $[t_0, t_f]$ is the time period of a total cost calculation, $p_6(k)$ is the power flow to the grid

from the sampling time $\Delta t = \frac{t_f - t_0}{N}$, and $p(k)$ is the TOU tariff function. Equation (6.8) is discretised by equation (6.9):

$$J = \Delta t \sum_{i=1}^k p_6(k) p(k) \quad (6.9)$$

where Δt is the sampling time and p is the electricity price at the k^{th} sampling time.

6.4.1 Objective function

The first objective is to maximise the sale of energy to the grid by taking advantage of the TOU electricity tariff, which is also used as input to the proposed model control strategies. The TOU

tariff is an important parameter in this model. As stated earlier, the maximisation of energy sales is achieved by selling more energy to the national grid during peak periods when the cost of energy is higher than during off-peak and standard periods. The classification of the TOU input parameter is off-peak, standard and peak, which also differs during low and high demand seasons. Consequently, the objective function is presented by the following expression:

$$- \max \sum_{i=1}^k P_6(k)P(k). \quad (6.10)$$

The second objective is to minimise the energy supplied by the main bus to the pump (P_3) and is expressed by:

$$\min \sum_{i=1}^k P_3(k). \quad (6.11)$$

The combination of the two objective functions renders the multi-objective function for the purpose of optimisation and is expressed by:

$$- \max \sum_{i=1}^k p_6(k)p(k) + \min \sum_{i=1}^k p_3(k). \quad (6.12)$$

6.4.2 Constraints

The constraints of this optimal control problem are listed as follows:

1. Equation (6.13) implies that the power supplied by the PV, PW and the hydro pump is equal to the total power supplied and the Kirchhoff law, which is applied to determine the total power in the main bus:

$$P_1(k) + P_2(k) + P_4(k) + P_9(k) - P_8(k) = P_3(k) + P_5(k) + P_6(k) \quad (6.13)$$

2. Equation (6.14) ensures that the power supplied by the PV, PW and the hydro pump at any hour of the day equals that of the local load and the load to be supplied to the grid during the peak period:

$$P_1(k) + P_2(k) + P_4(k) + P_9(k) - P_8(k) \geq P_5(k) + P_6(k) \quad (6.14)$$

3. Equation (6.15) ensures that the power supplied by the PV, PW and the hydro pump directly to the local load or to the grid is greater than or equal to zero:

$$P_1(k) \geq 0; P_2(k) \geq 0; P_4(k) \geq 0; P_9(k) \geq 0; P_8 \geq 0 \quad (6.15)$$

4. Each energy source i is constrained by minimum and maximum values as specified in equation (6.16):

$$P_i^{\min} \leq P_i(k) \leq P_i^{\max} \quad (6.16)$$

5. Equation (6.17) ensures the minimum and maximum steady state frequencies. They define the tolerance band for the quasi-steady state system frequency after the occurrence of a reference incident, assuming predefined system conditions.

$$S^{\min} \leq S(0) + \Delta t \cdot \sum_{i=1}^k \frac{P_9(k)}{\omega} - \Delta t \cdot \sum_{i=1}^k \frac{P_8(k)}{\omega} \leq S^{\max} \quad (6.17)$$

6. Equation (6.17) ensures the minimum and maximum expected instantaneous frequency after a reference incident (loss of generation or loss of load) assuming predefined system conditions.

$$f^{\min} \leq f(k) \leq f^{\max} \quad (6.18)$$

7. Equation (6.19) ensures that the water in the upper reservoir will not be less than the minimum value or higher than the maximum value:

$$V^{\min} \leq V(0) + \Delta t \cdot c_p \sum_{i=1}^k P_3(k) - \Delta t \cdot \frac{1}{c_t} \sum_{i=1}^k P_4(k) \leq V^{\max} \quad (6.19)$$

For all $k=1, \dots, N$ is the sampling time. $P_1(k), P_2(k), P_4(k), P_9(k)$ and $P_8(k)$ are the control variables representing the energy flow from the PV, PW, mechanical power of the conventional source, electrical power of the conventional source and the energy supplied by the PH system to the load at any time (t), while $P_3(k), P_5(k)$ and (P_6) are the variables representing the energy flow to the pump, the energy flow to the local load and the energy flow to the grid respectively.

6.4.3 Application of the Model

The model was applied using *fmincon*, a MATLAB function, and was selected because of the non-linearity of the system, which means that it has a multi-objective function and constraints. To derive the constraints as adapted by the model, the canonical form of the constraint must be applied to this format. It has the following general form:

Min f(x)

subject to the following constraints

$$\begin{cases} A \cdot X \leq b \\ A_{eq} \cdot X = b_{eq} \\ L_b \leq X \leq Ub \end{cases} \quad (6.20)$$

X is a binary integer vector. In this thesis, it is the flow of energy from different components in the hybrid system. It can be formulated by

$$X = [x_1, x_2, \dots, x_N]. \quad (6.21)$$

The constraints presented in equations (6.13 to 6.19) are represented in this model as equation (6.20). The hydro pump should compensate for possible overproduction of the renewable energy source. However, it is important to reserve storage capacity in the reservoir at all times, therefore the reservoir must never be filled to capacity. The changes in water flow in the upper reservoir can be expressed as:

$$\Delta V = t_s \left(c_p P_3(k) - \frac{1}{c_t} P_4(k) \right). \quad (6.23)$$

Taking into consideration the above, the constraint in equation (6.20) applied to equation (6.23) will change to

$$V^{\min} \leq V(0) + \Delta t \cdot c_p \sum_{i=1}^k P_3(k) - \Delta t \cdot \frac{1}{c_t} \sum_{i=1}^k P_4(k) \quad (6.24)$$

and

$$-V^{\min} \geq -V(0) - \Delta t \cdot c_p \sum_{i=1}^k P_3(k) + \Delta t \cdot \frac{1}{c_t} \sum_{i=1}^k P_4(k). \quad (6.25)$$

Equations (6.24) and (6.25) are formulated as an inequality constraint from the model of equation (6.20), where k is the range from 1 to N , and equations (6.24) and (6.25) generate N inequality under a matrix format. The formulated matrix consists of dimensions $(2N + 1) \times N$ and b is a vector with dimension N .

The second step of the constraint is linked to the speed or the frequency, which means that the constraints presented in equations (6.13 to 6.19) are represented in this model as equation (6.21), in the case of the frequency. If there is an increase or decrease in the load in the network there will be a change in the frequency or the speed of the rotor in the conventional source of power. In this case the scenario is that the change of speed or frequency occurs when the renewable energy must be connected to the normal grid with the aim to sell the electricity. The equation that indicates the variation in speed is given by:

$$\Delta S = t_s \left(\frac{P_9(k)}{\omega} - \frac{P_8(k)}{\omega} \right). \quad (6.26)$$

Taking into consideration the above, the constraint in equation (6.21) applied to equation (6.26) will change to

$$S^{\min} \leq S(0) + \Delta t \sum_{i=1}^k \frac{P_9(k)}{\omega} - \Delta t \sum_{i=1}^k \frac{P_8(k)}{\omega} \quad (6.27)$$

and

$$-S^{\min} \geq S(0) - \Delta t \sum_{i=1}^k \frac{P_9(k)}{\omega} + \Delta t \sum_{i=1}^k \frac{P_8(k)}{\omega}. \quad (6.28)$$

Equations (6.27) and (6.28) are formulated as an inequality constraint from the model of equation (6.20), where k is the range from 1 to N , and equations (6.27) and (6.28) generate N inequality under a matrix format. The formulated matrix consists of dimensions $(2N + 1) \times N$ and b is a vector with dimension N .

6.5 MODEL PARAMETERS

The power demands of different consumers vary according to their specific needs. Therefore, the grid cannot have a constant load profile, since it varies from time to time and depends on the load type, which can be classified as domestic, industrial or commercial. The variation in load profile has an impact on the flow of energy to the grid, which could be related to the price of electricity. This has become a key focus of the energy control model in this thesis, which has been referred to as the TOU tariff. The Eskom Miniflex tariff is employed during both high and low demand seasons. Moreover, in this study the load profile for weekdays as well as weekends was considered.

Tariff for the high demand season:

$$p(t) = \begin{cases} p_o = 0.37376 \text{ R/kWh} & \text{if } t \in [0,6] \cup [22,24] \\ p_s = 0.6953 \text{ R/kWh} & \text{if } t \in [6,7] \cup [10,18] \\ p_p = 2.2952 \text{ R/kWh} & \text{if } t \in [7,10] \cup [18,22] \end{cases} \quad (6.29)$$

Tariff for the low demand season:

$$p(t) = \begin{cases} p_o = 0.3358 \text{ R/kWh} & \text{if } t \in [0,6] \cup [22,24] \\ p_s = 0.5 \text{ R/kWh} & \text{if } t \in [6,7] \cup [10,18] \\ p_p = 0.76 \text{ R/kWh} & \text{if } t \in [7,10] \cup [18,22] \end{cases} \quad (6.30)$$

where R is the South African currency, rand, and t is the time of any day in hours (from 0 to 24).

6.5.1 Power sources

Renewable energy sources are solar power, wind power and the PH system. The control variables include $p_1(k)$, $p_2(k)$, $p_3(k)$, $p_4(k)$, $p_9(k)$ and $p_8(k)$ and are expressed in kW. Each solar power and wind power source is determined by its own profile, which varies during the 24-hour period between the $[t_0, t_f]$ values of the control horizon for the model. The maximum and minimum values are divided by an N sample interval into sampling time Δt in the control horizon. A 25 kW PV generator produces about 11 kW to 15 kW in the morning and 9 kW to 20 kW in the afternoon, while 20 kW wind power produces 8 kW to 12 kW and 10 kW to 15 kW in the morning and afternoon peak periods respectively. The conventional source is represented by mechanical power which varies between 0 and 100 kilowatt turbine, which can be used as 50 kilowatts. When the load absorbs mechanical power between 50 and 100 KW a synchro machine operates as a motor.

6.5.2 Grid power and local load

The local demands are represented by a clinic and family houses. The profile will change with two kinds of loads, a commercial load and a domestic load. Energy is supplied to the grid in order

to maximise sales when the local demands in the control horizon have been met at different times of the day. The benefits to the utility are thus that the network can operate optimally by reducing losses into the system.

6.6 RESULTS

Figures (6-1) and (6-3) depict the energy flow during the 24-hour period. At night and in the early morning the load is met by the PHS system and sales to the grid are maximised during peak periods. Constraints (6.19) and (6.13) are met by ensuring that the power supplied by the PV, PW and the HP system at any hour of the day is equivalent to that of the local load and the load supplied to the grid during the peak period; it must thus be equal to or greater than the combined loads. The dynamics of the reservoir are demonstrated in Figures (6-2) and (6-4), and the network dynamic is represented by Figures (6-3) and (6-6); it can be seen by the frequency in the time when the rotor speed changes.

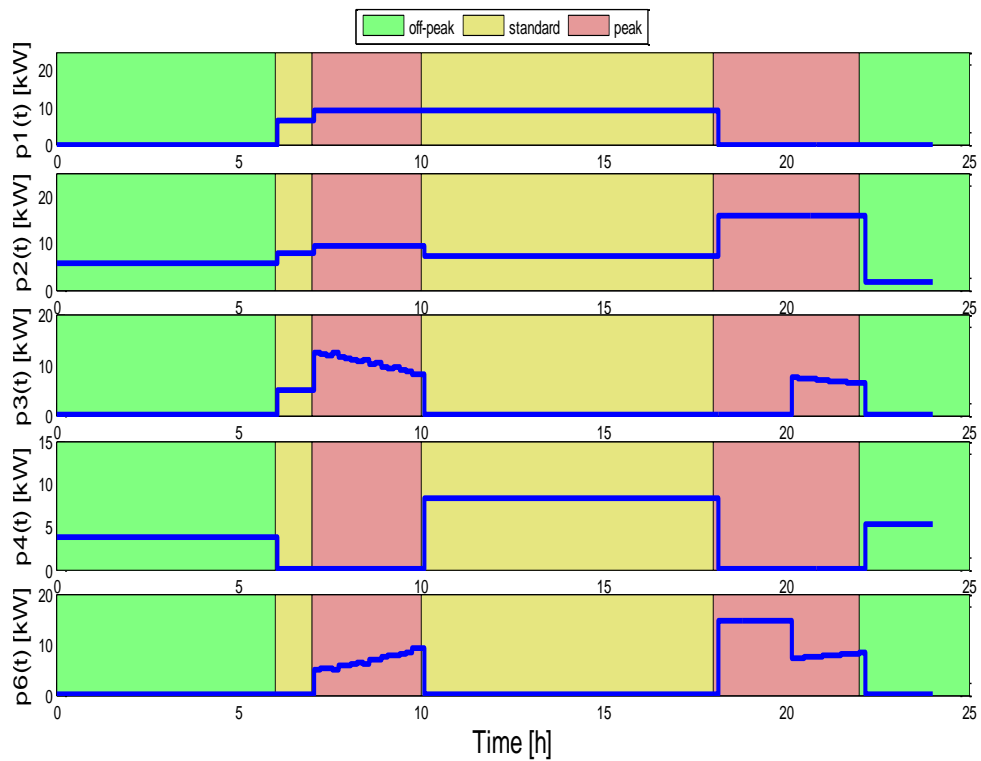

Figure 6-1: Low demand season – weekday power flow

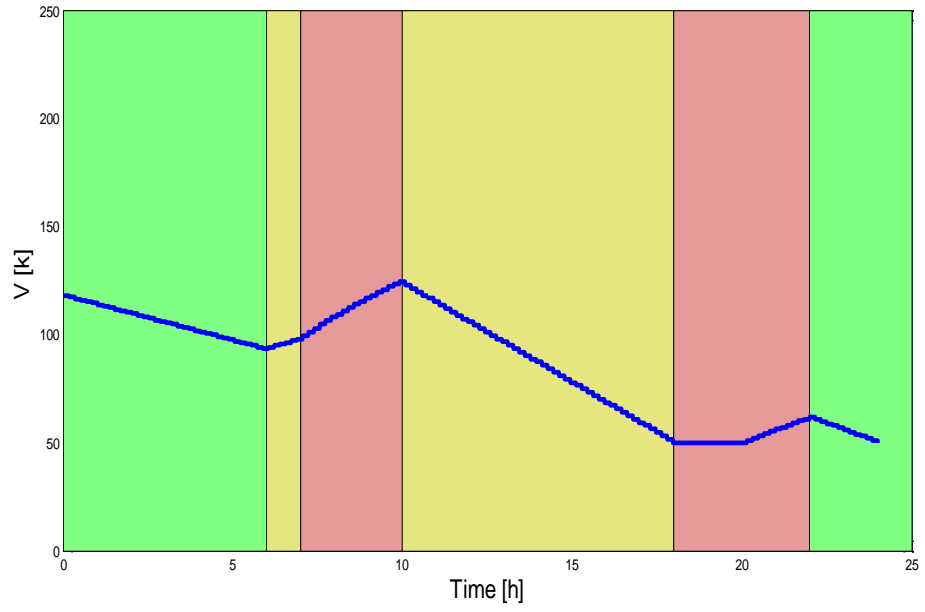

Figure 6-2: The reservoir dynamic (low demand season weekday)

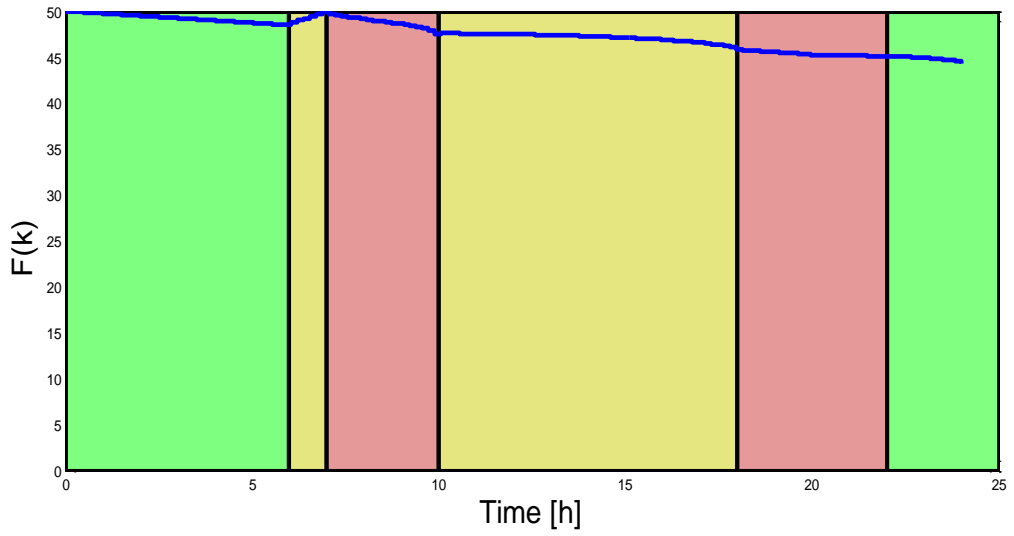

Figure 6-3: The frequency variation in the network

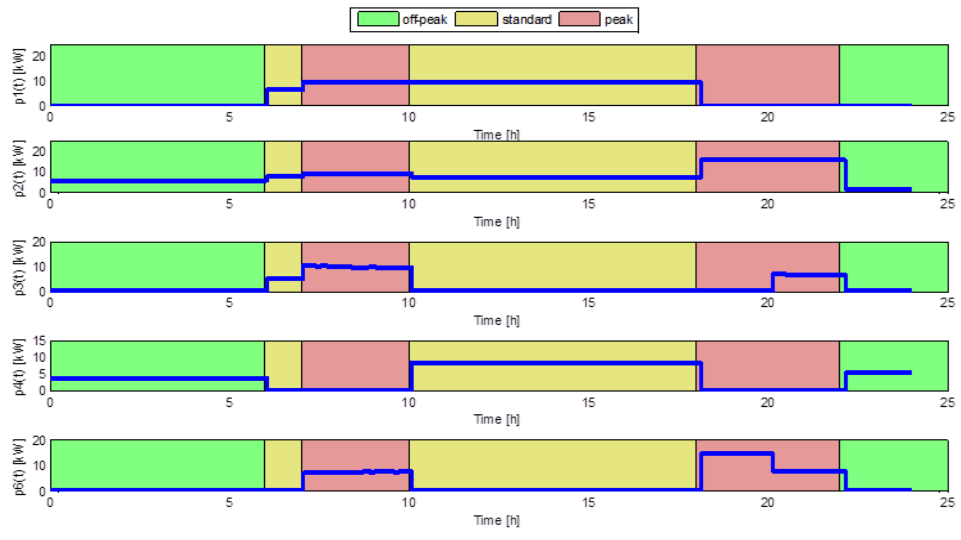

Figure 6-4: Low demand season – weekend power flow

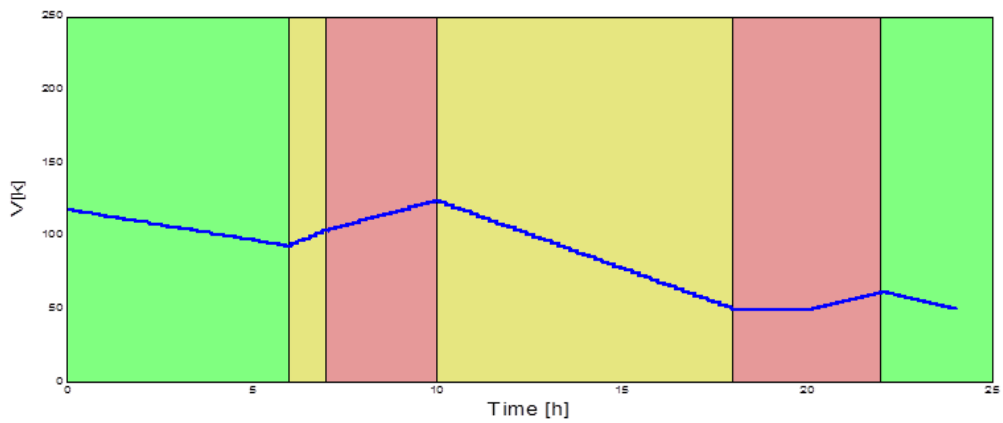

Figure 6-5: The reservoir dynamic (low demand season weekend)

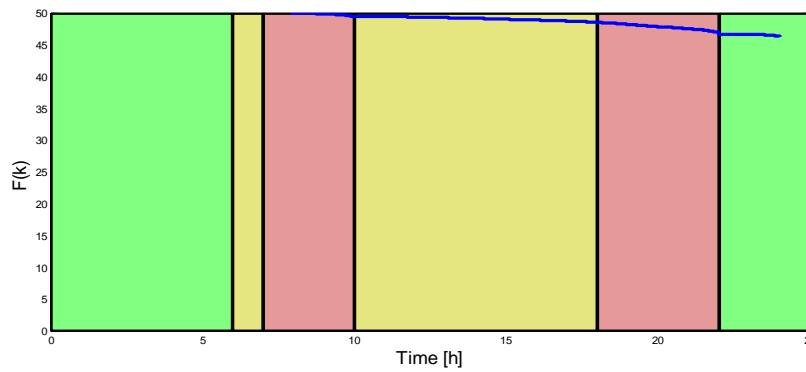

Figure 6-6: Frequency variation in the network

Figures 6-7 and 6-8 shows the difference of power, when the renewable system is connected to grid to relieve the network under stress, parameter such as frequency and volatge will be affected if there is no enough capacity to supply grid.

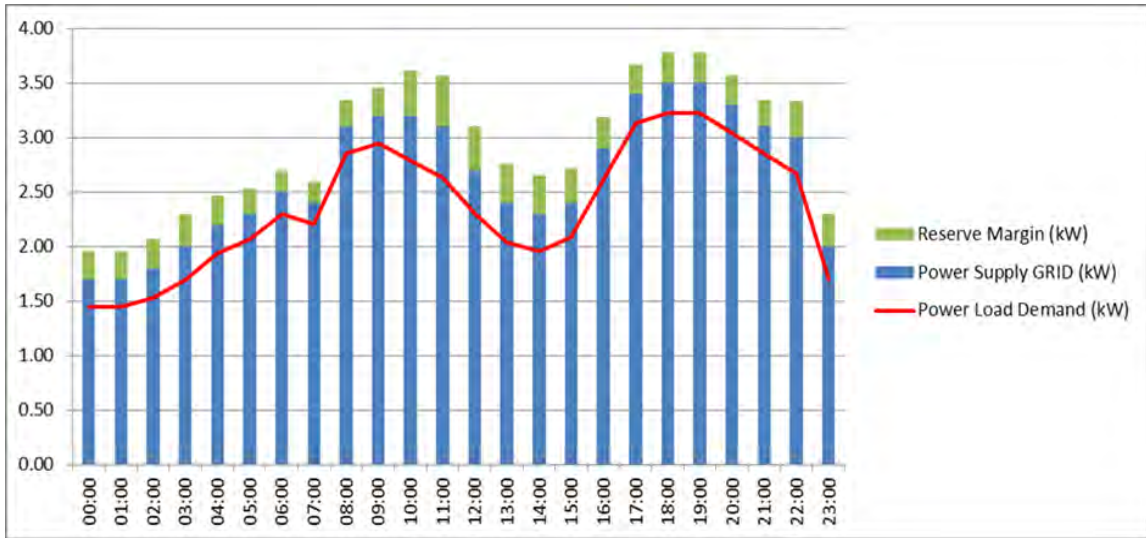

Figure 6-7: The Graph of daily load cycle: Power flow under normal condition, the x axis is the time in hour and the y axis represent the power in kW.

In this case the conventional source have the reserve margin less than 8%, it can be seen through figure 6.8 the difference between the power supply by the grid and the load demand.



Figure 6-8: The Graph of daily load cycle: Grid connected Photovoltaic system, the x axis is represented by the time in hour and the y axis represent the power in kW.

With the input from the renewable energy source, there is an improvement in the reserve margin and the frequency according to equations (6.27 and 6.28), the network can find its stability

6.7 SUMMARY

The results show the minimisation of pump use and the maximisation of the sale of energy. The model can benefit the utility by meeting its reserve constraints without overloading its generators. On the other hand, customers can adapt their energy consumption based on the TOU tariff scheme by shifting (reducing) their loads from peak periods when energy is more costly to off-peak and standard periods at a cheaper energy rate. The model also presents the change of frequency when the renewable energy source is connected to the network.

CHAPTER 7: CONCLUSION AND FUTURE RESEARCH

7.1 CONCLUSION

In the first application of this work there is a multiple objective; the first part is to maximise the sales of energy to the grid by taking advantage of the TOU electricity tariff, but at the same time, the objective is to minimise the fuel cost of the DG. Different system constraints such as power limitations, SOC of the battery, etc. were taken into account. The optimal energy dispatch model of a hybrid system was described and the optimal energy flows were analysed using the `fmincon` solver. The optimisation model developed yielded more savings than the diesel-only scenario. The results also show how daily and seasonal variations in demand affect the operational cost of the hybrid system. For both the low-demand and high-demand seasons, the weekend fuel costs are higher than weekday costs. In the high-demand season fuel costs are higher than in the low-demand season and the lower radiation levels of the high-demand season also imply more use of extra sources. This shows that the daily and seasonal demand changes are important aspects to be considered, as they affect the operational cost and the energy flows considerably. It has been shown that the optimisation model that was developed achieves optimal fuel costs in the micro grid network and can be used in the analysis of the power and energy flows in any given system. A more practical approach to the estimation of the fuel costs reflecting variations of power consumption behaviour patterns is thus presented in this work, which can be extrapolated to give an accurate estimate of the daily diesel fuel cost.

In the second part of the work a model was adopted in which the battery is replaced by a hydro-pump because of its advantage over battery. In this scenario a model was developed and the multi-objective function was developed with the same aim to sell the energy into the grid during the peak period. The results reflected firstly the sale and secondly the reservoir dynamic. The work was extended in the fifth chapter with the introduction of MPC to the normal optimisation. This was applied to the energy management of the PV, PW and hydro pump power supply system. Comparisons have been made of the performances of the open-loop model and closed-loop control, which is defined as MPC without disturbances and with disturbances for both low demand season and high demand season. The performance of the MPC had been found to be generally better, indicating that its robustness with respect to disturbances was superior to that of the open-loop system. The results simulated proved to have a great impact on the applications of the model predictive approach in the energy dispatch operation. Although the closed-loop system might be too sophisticated for domestic sector application, it may be beneficial for individual and industrial sector applications. The last work presented is the impact of the frequency variation when there is an increase of the load into the network. This variation will be shown by the change of the speed of the rotor, the electrical power as well as the mechanical power. In all the models the TOU was used, which is an important parameter in the model that was developed. The maximisation of energy sales was achieved by selling more energy to the national grid during the peak period when the energy cost is higher than during off-peak and standard periods.

7.2 FUTURE RESEARCH

For the further research, more topics can develop on optimal control of micro grid such as frequency load shedding scheme, this will include the balancing of the load, voltage control and frequency. The analysis will also focus on the combination of the tie line power which can be connected as a model between the conventional power sources and the renewable energy system, and its frequency deviations, which is known as area control (ACE), the minimization of the tie line optimal control in such a way that frequency and tie line power error are minimised with the outcome on power balance which will be achieved between generation and load. The tie line

connected on the micro grid consists of two parts, which are the conventional source and the renewable energy source, each made up of a synchronous generator. The control application of the active power and frequency into a network which will be referred as load frequency control, the storage system will be part of the renewable energy system, it be can utilise to provide a fast way for active power compensation, and the same time taking its dynamic into consideration to improve the control performance. The objective function must be develop and the application of the control strategies will based on the frequency deviation and the area control error.

REFERENCES

- [1] Tong W. “Wind power generation and wind turbine design.” Southampton Boston: WTT Press, 2010.
- [2] IEA world energy outlook. 2nd ed. International Energy Agency Publication, 2006.
- [3] IEA Renewable energies for remote areas and islands, April 2012.
- [4] Shaahid, S.M., Elhadidy, M.A., “Economic analysis of hybrid photovoltaic–diesel– battery power systems for residential loads in hot regions - A step to clean future.” *Renewable and Sustainable Energy Reviews* 12, 488–503, April 2008.
- [5] Ma T., Yang H., Lu L., Peng J. “Technical feasibility on a standalone hybrid solar–wind system with pumped hydro storage for a remote island in Hong Kong.” *Renewable Energy* (69), 7-15, 2014.
- [6] Bemporale A. and Morati M. “Control of Systems Integrating Logic Dynamic and Constraints” *Automatic.* vol. 35 no. 3 pp. 407- 411, 1999.
- [7] Saini R.P., “Large scale energy storage systems.” Indian Institute of Technology Roorkee, 2010.
- [8] Dhrub, S.S. and Sopian, K. “Electricity generation of hybrid PV/wind systems in Iraq”, *Renewable Energy*, vol. 35, pp. 1303-1307, 2010.
- [9] Belfikira, R., Zhang, L. Baraka, G. “Optimal sizing study of Hybrid wind/PV/diesel power generation unit.” *Solar Energy* 85, 100-110, 2011.
- [10] Dufo-Lopez R., and Bernard Augustin J.L “Design and control strategies of PV diesel systems using genetic algorithms.” *Solar Energy* 79, 33 – 34, 2005.
- [11] Tina, G., Gagliano S., and Raiti S., “Hybrid solar/wind power system probabilistic modeling for long term performance assessment.” *Solar Energy*, 80, 578-588.
- [12] Celik, A.N. “Techno-economic analysis of autonomous PV-wind hybrid energy systems using different sizing methods”, *Energy Conversion and Management*, 44, 1951-1968, 2003.
- [13] Yang, H., Zhou, W., and Lou, C. “Optimal design and techno-economic analysis of a hybrid solar-wind power generation system”, *Applied Energy*, 86, 163-169, 2009.
- [14] Bakos, G.C., and Tsagas, N.F. “Technoeconomic assessment of a hybrid solar/wind installation for electrical energy saving”, *Energy and Buildings*, 35(2), 139-45, 2003.
- [15] Ren H., Zhou W., and Nakagami “Multi-objective optimisation for the operation of distributed energy systems considering economic and environmental aspects.” *Applied Energy*, 87, 2010.
- [16] Yen H, and Su-yin L. “Economic analysis and optimal energy management models for microgrid systems. A case study in Taiwan.” *Applied Energy*, 103, 145-154. 2013.
- [17] Wies S.W., Johnson R.A., and Chubb T.J. “Simulink model for economic analysis and environmental impacts of a PV with diesel-battery system for remote villages.” *Power System IEEE Transactions on Power System*, 20 (2), 692-700, 2011.

- [18] Collares-Pereira, M and Rabl. "The average distribution of solar radiation correlation between diffuse and hemispherical and between daily and hourly insolation values." *Solar Energy*, 22, 155-164., 2011
- [19] Vine E. "Breaking down the silos: The integration of energy efficiency, renewable energy, demand response and climate change." *Energy Efficiency*, 1, 49-63; 2008.
- [20] Lee T.-Y., and Chen C.-L. "Wind-photovoltaic capacity coordination for a time of use rate industrial user." *IET Transactions on Renewable Power Generation*; 3(2), 152-67, 2009.
- [21] Marriskainen M., and Coburn J. "The role of information and communication technologies (ICTs) in household energy consumption/prospects for the UK." *Energy Efficient* 12053-010-9094-2, 2010.
- [22] Zhou W., Lou C., Liz Lu L., and Yang H. "Current status of research on optimum sizing of stand-alone hybrid solar-wind power generation system." *Applied Energy*, 87(2): 380-9, 2010.
- [23] Strupzewskim A. "Accident risks in nuclear -power plants." *Applied Energy*, 75(1-2), 79-86, 2003.
- [24] Skoglund A., Leijon M., Rehn A., Lindahi M., and Waters R. "On the physics of power and economics of renewable electric energy sources – Part II." *Renewable Energy*, 35-(8), 1735-40, 2010.
- [25] Evan A., Strezov V., and Evan T.J. "Assessment of sustainability indicators for renewable energy technologies." *Renewable and Sustainable Energy Reviews.*" 13(5), 1082-8, 2009.
- [26] Lund H. "Renewable energy strategies for sustainable development." *Energy* 32(6), 912-9, 2009.
- [27] Hepbasli A. "A key review on energetic analysis and assessment of renewable energy resources for a sustainable future." *Renewable and Sustainable Energy Reviews*, 12(3), 593-661, 2008.
- [28] Varun P., Rakessh R., and Bhat I.K. "Energy economics and environmental impacts of renewable energy systems." *Renewable and Sustainable Energy Reviews.*" 13(9), 2716-661, 2008.
- [29] Jebaraj S., and Iniyani S. "A review of energy models." *Renewable and Sustainable Energy Reviews.*" 10(4), 281-311, 2006.
- [30] Pardalos P.M., and Resende M.G.C. "Handbook of applied optimisation", Oxford University Press 2002.
- [31] Du D.-H., and Pardalos P.M., "Handbook of applied optimisation: Supplement volume B", Springer, 2005.
- [32] Garey M.R. and Johnson D.S, "Computers and intractability: A guide to the theory of NP-completeness", San Francisco: W.H. Freeman and Company, 1979.
- [33] Gendreau M., and Potvin J.-Y. "Handbook of metaheuristics. International series in operations research and management science", Springer, 2010.
- [34] Alba E., "Parallel metaheuristic: A new class of algorithms", Wiley and Sons, 2005.
- [35] Glover F., Kochenberger G.A., "Handbook of metaheuristics", International series in operations research management science, vol. 57. Springer, 2003.

- [36] Hajela P., and Y-Lin C. "Genetic search strategies in multi-criterion optimal design structural optimisation." 4, 99-107; 1992.
- [37] Goldberg DE, "Genetic algorithms in search optimisation and machine learning", Addison Wesley, 1989.
- [38] Banos R., Gil C., Paechter B., and Ortega J. "A hybrid meta-heuristic for multi-objective optimisation MOSATS." *Journal of Mathematical Modelling and Algorithms*, 6(2), 213-30, 2007.
- [39] Ehrgott M., and Gandibleux X. "Hybrid metaheuristics for multi-objective combinatorial optimisation." *Hybrid Metaheuristics: Studies in Computational Intelligence*, 114, 221-59, 2008.
- [40] Ma, T., and Nakamori, Y., "Modelling technological change in energy systems - from optimisation to agent based modelling." *Energy*, 34(7), 873-9, 2009.
- [41] Cai Y.P., Huang G.H., Yang Z.F., Lin Q.G., and Tan Q. "Community-scale renewable energy systems planning under uncertainty - an interval chance-constrained programming approach." *Renewable and Sustainable Energy Reviews* 13(4), 721- 35, 2009.
- [42] Soroudi A., Ehsan M., and Zareipour H., "A practical eco-environmental distribution network planning model including fuel cells and non-renewable distributed energy resources." *Renewable Energy*, 36(1), 179-88, 2011.
- [43] Kahraman C., Kaya I., and Cebi S. "A comparative analysis for multi attribute selection among renewable energy alternative using fuzzy axiomatic design and fuzzy analytic hierarchy process." *Energy* 34, 1603-16. 2009.
- [44] Connolly D., Lund H., Mathiesen BV., and Leahy M. "A review of computer tools for analysing the integration of renewable energy into various energy systems." *Applied Energy*, 87(4), 1059- 82, 2010.
- [45] Sadegheih A., "A novel formulation of carbon emission costs for optimal design configuration of system transmission planning." *Renewable Energy*, 35(5), 1091-2, 2010.
- [46] Sadegheih A., "Optimal design methodologies under the carbon emission trading program using MIP, GA, SA and TS" *Renewable and Sustainable Energy Review*, 2010.
- [47] Zangeneh A., Jadid S., and Rahimi-Kian A. "Promotion strategy off clean technologies in distributed generation expansion planning." *Renewable Energy*, 34(12), 2765-73, 2009.
- [48] Cai Y.P., Huang G.H., and Yang Z.F. "Planning of community scale renewable energy management systems in a mixed stochastic and fuzzy environment" *Renewable Energy*, 34(7), 1833-47, 2009.
- [49] Kowalski K., Stagi S., Madlener R., and Oman I. "Sustainable energy futures: Methodological challenges in combining scenarios and participatory multi-criteria analysis." *European Journal of Operational Research*, 197(3), 1063-74., 2010
- [50] AlRashidi M.R., and EL-Naggar K.M., "Long term electric load forecasting based on a particle swam optimisation." *Applied Energy*, 87(1), 320-6, 2010.
- [51] Dicorato M., Forte G., and Trovato M. "Environmental-constrained energy planning using energy efficiency and distributed generation facilities." *Renewable Energy*, 31(10-11), 1297-313, 2008.

- [52] Ahadi-Osku T., Alperin H., Nowak I., Cziela F., and Tsatsaronis G. "A relaxation-based heuristic for the design of cost-effective energy conversion systems." *energy conversion system*. 31(10-11), 346-57, 2008.
- [53] Fleten S.-E., Maribu K.M., and Wangensteen I. "Optimal investment strategies in decentralised renewable energy power generation under uncertainty", *Renewable Energy* 32(5), 803-15, 2007.
- [54] Hiremath R.B. Shika S, and Ravindranath N.H. "Decentralized energy planning: Modelling and application – a review." *Renewable and Sustainable Energy Review*, 11(5), 729-52, 2007.
- [55] Yokoyama R., Waku T., and Satake R. "Prediction of energy demands using neural network with model identification by global optimisation." *Energy Conversion and Management*, 50, 319-27, 2009.
- [56] Mitchell K., Nagrial M., and Rizk J. "Simulation and optimisation of renewable energy systems." *International Journal of Electrical Power and Energy Systems*, 27(3), 177-88, 2005.
- [57] Alvarez-Valdes R., Crespo E., Tamarit J.M., and Villa F. "GRASP and path relinking for project scheduling under partially renewable resources." *European Journal of Operational Research*, 189(3), 1153-70, 2008.
- [58] Alarcon-Rodriguez A., Ault C., And Galloway S. "Multi-objective planning of distributed energy resources: A review of the state of the art." *Renewable and Sustainable Energy Reviews*, 14, 1353-66, 2010.
- [59] Pohekar S.D., Ramachandran M., "Application of multi-criteria decision making to sustainable energy planning – A review." *Renewable and Sustainable Energy Review*, 8(4), 365 -81, 2008.
- [60] Sood Y.R., and Singh R., "Optimal model of congestion management in deregulated environment of power sector with promotion of renewable energy sources." *Renewable Energy*, 36(8), 828-36, 2010.
- [61] Nicknam T., and Firouzi B.B., "Practical algorithm for distribution state estimation including renewable energy sources." *Renewable Energy*, 34:1236-45, 2009.
- [62] Ostergaard P.A., "Reviewing optimisation criteria for energy systems analyses of renewable energy integration." *Energy*, 34, 1236-45, 2009.
- [63] Loken E. "Use of multicriteria decision analysis methods for energy planning problems." *Renewable and Sustainable Energy Review*, 11 (7) 1584- 95; 2007.
- [64] Yongping Y., Rongrong Z., Liqiang D., Masek O., and Oakey J. "Study on multi-objective optimisation of load dispatch including renewable energy and CCS technologies." *International Journal of Energy Research*, 34, 702-15, 2010.
- [65] Franco A., and Salza P., "Strategies for optimal penetration of intermittent renewable energy systems based on techno-operational objectives." *Renewable Energy*, 36 (2), 743-53, 2011.
- [66] Wang J.J., Jing Y.Y., and Zhao J.H. "Review on multi-criteria decision analysis aid in sustainable energy decision making." *Renewable and Sustainable Energy Review*, 13 (9), 2263-78, 2009.

- [67] Niknam T, Meymand HZ, and Nayeripour M. “A practical algorithm for optimal operation management of distribution network including fuel cell power plants.” *Renewable Energy*, 35 (8), 1696-714, 2010.
- [68] Lohnord N., and Minner S., “Optimal day-ahead trading and storage of renewable energies an approximate dynamic programming approach.” *Energy Systems*, 1(1), 61-77, 2010.
- [69] Viera F., and Ramos H.M. “Optimisation of operational planning for wind/hydro hybrid water supply systems.” *Renewable Energy*, 34(3), 928-36, 2009.
- [70] Reza J., Martinez J., Banos R., and Gil C. “Optimal design of gravity-fed looped water distribution networks considering the resilience index.” *ASCE Journal of Water Resources Planning and Management*, 22(10), 1367-79, 2008.
- [71] Reza J., Martinez J., Gil C., and Banos R. “Application of several meta-heuristic techniques to the optimisation of real looped water distribution networks.” *Water Resources Management*, 22(10), 1367-1379, 2008.
- [72] Banos R., Gil C., Reza J., and Martinez J. “Scatter search for multi-objective optimisation: A comparative study.” *Computational Optimisation and Applications*, 42 (3), 421-41, 2009.
- [73] Banos R., Gil C., Reza J., and Ortega J. “A pareto-based memetic algorithm for optimisation of looped water distribution systems.” *Engineering Optimisation*, 42(3), 223-40, 2010.
- [74] Li Y.F., Li Y.P., Huang G.H., and Chen X. “Energy and environmental systems planning under uncertainty – An inexact fuzzy-stochastic programming approach.” *Applied Energy*, 87(10), 3189-211, 2010.
- [75] Zhao M., Chen Z., and Blaabjerg F., “Optimisation of electrical system for offshore wind farms via genetic algorithm.” *IET Transactions on Renewable Power Generation*, 3(2), 205-16, 2009.
- [76] Kumar A., and Kandpal T.C. “Renewable energy technologies for irrigation water pumping in India: A preliminary attempt towards potential estimation.” *Energy*, 32(5), 861-70, 2007.
- [77] Benini E., and Toffolo A. “Optimal design of horizontal—axis wind turbine blades-element theory and evolutionary computation.” *Journal of Solar Energy Engineering*, 124(4), 357-63, 2002.
- [78] Maalawi K.Y., and Negm H.M. “Optimal frequency design of wind turbine blades.” *Journal of Wind Engineering and Industrial Aerodynamics*, 90(8), 961-86, 2002.
- [79] Sareni B., Abdelli A., Roboam X., and Tran D.H. “Model simplification and optimisation of a passive wind turbine generator.” *Renewable Energy*, 34(12), 2640-50, 2009.
- [80] Lund E., and Stregmann J. “On structural optimisation of composite shell structures using a discrete constitutive parametrization.” *Wind Energy*, 8, 109-24, 2005.
- [81] Svanberg K., “The method of moving asymptotes - A new method for structural optimisation.” *International Journal for Numerical Methods in Engineering*, 24, 359-73, 1987.
- [82] Jensen F.M., Puri A.S., Dear J.P., Branner J., and Morris A. “Investigating the impact of non-linear geometrical effects on wind turbine blades - part 1: Current status of design and test methods and future challenges in design optimisation.” *Wind Energy* doi: 10.1002/we.415, 2010.

- [83] Li H., Chen Z., and Polinder H. "Optimisation of wind turbine performance with data driven models." *IEEE Transactions on Energy Conversion*, 24(1), 82- 92, 2009.
- [84] Kusiak A., Zhang Z., and Li M. "Optimisation of wind turbine performance with data driven models." *IEEE Transactions on Sustainable Energy*, 1(2): 62-76, 2010.
- [85] Renewables 2010. Global status report. Deutsche Gesellschaft für Technische Zusammenarbeit (GTZ) GmbH.
- [86] Xundong W., Shen W.Z., Zhu W.J., Sorensen J.N., and Jin C. "Shape optimisation of wind turbine blades." *Wind Energy*, 12, 781-803, 2009.
- [87] Fuglsang P., and Thomsen K. "Site – specific design optimisation of 1.5 – 2.0 MW wind turbines." *Journal of Solar Energy Engineering*. 123(4):296- 303; 2001.
- [88] Fuglsang P., Bak C., Schepers J.G., Bulder B., and Cokerill T.T. "Site specific design optimisation of wind turbines." *Wind Energy*, 5, 261-79, 2002.
- [89] Kusiak A., and Zheng H. "Optimisation of wind turbine energy and power factor with an evolutionary computation algorithm." *Energy*, 35, 1324-32; 2010.
- [90] Kusiak A., Zheng H., and Song Z. "Power optimisation of wind turbines with data mining and evolutionary computation." *Renewable Energy*, 35, 695 –702, 2010.
- [91] Kongnam C., Nuchprayoon S., Premrudeepreechacharn S., and Uatrongiit S. "Decision analysis on generation capacity of a wind park." *Renewable and Sustainable Energy Reviews*, 13(8), 2126-33, 2009.
- [92] Hameed Z., Hong Y.S., Cho Y.M., Ahn S.H., and Song C.K. "Condition monitoring and fault detection of wind turbines and related algorithms: A review." *Renewable and Sustainable Energy Reviews*, 13(1), 1-39, 2009.
- [93] Ustuntas T., and Sahin A. "Wind turbine power curve estimation based on cluster centre fuzzy logic modelling." *Journal of Wind Engineering and Industrial Aerodynamics*, 96(5), 611-20, 2008.
- [94] Shimizu E., Isogai K., and Obayashi S. "Multi-objective design study of a flapping wing power generator." *Journal of Fluids Engineering*, 130(2), 021104-11, 2008.
- [95] Rasuo B.P., and Bengin A.C. "Optimisation of wind farm layout." *FME Transactions* 38, 107-14, 2010.
- [96] Grady S.A. Hussaini M.Y., and Abdullah M.M. "Placement of wind turbines using genetic algorithms." *Renewable Energy*, 30(12), 259-70, 2005.
- [97] Emami A., and Noghreh P. "New approach on optimisation in placement of wind turbines within farm by genetic algorithms." *Renewable Energy*, 35(7), 1559-64, 2010.
- [98] Serrano J., Gonzalez A.G., and Castro J., Riquelme, B.M. "Optimisation of wind farm turbines layout using an evolutive algorithm." *Renewable Energy*, 35, 167-81, 2010.
- [99] Kusiak A., and Song Z. "Design of wind farm layout for maximum wind energy capture." *Renewable Energy*, 35(3), 685-94, 2010.
- [100] Herbert G.M.J., Iniyani S., and Goic R. "Performance, reliability and failure analysis of wind farm in developing country." *Renewable Energy*, 35 (12), 2739-51, 2010.
- [101] Mustakerov I., and Borissova D. "Wind turbines type and number choice using combinatorial optimisation." *Renewable Energy*, 35(9), 1887-94, 2010.

- [102] Dukpa A., Duggai I., Venkatesh B., and Chang L. "Optimal participation and risk mitigation of wind generators in an electricity market." *IET Transactions on Renewable Power Generation*, 4(2), 165-75, 2010.
- [103] Kusiak A., Li W. "Estimation of wind speed: A data-driven approach." *Journal of Wind Engineering and Industrial Aerodynamics*, 98(10-11), 559-67, 2010.
- [104] Abdel-Aal R.E., Elhadidy M.A., and Shaahid S.M. "Modelling and forecasting the mean hourly wind speed time series using GMDH-based abductive networks." *Renewable Energy*, 34(7), 1686-99, 2009.
- [105] Pinson P., Christensen L.E.A., Madsen H., Sorensen P.E., Donovan M.H., and Jensen L.E. "Regime switching modelling of the fluctuations of offshore wind generation." *Journal of Wind Engineering and Industrial Aerodynamics*, 96 (12), 2327-47, 2008.
- [106] Zhang L., and Wirth A. "Wind energy management with battery storage." *Journal of the Operational Research Society*, 61, 1510 – 22, 2010.
- [107] Boqiang R., and Chuanwen J. "A review on the economic dispatch and risk management considering wind power in the power market." *Renewable and Sustainable Energy Reviews*, 13 (8), 2169 – 74 2009.
- [108] Kongnam C., and Nuchprayoon S. "A particle swarm optimisation for wind energy control problem." *Renewable Energy*, 35 (11), 2431 – 8, 2010.
- [109] Kuo C.-C. "Wind energy dispatch considering environmental and economic factors." *Renewable Energy*, 5 (10), 2217–27, 2010.
- [110] Ko H., and Jatskevich J. "Power quality control of wind-hybrid power generation system using fuzzy-LQR controller." *IEEE Transactions on Energy Conversion*, 22(2), 516–27, 2007.
- [111] Kusiak A., Li W., and Song Z. "Dynamic control of wind turbines." *Renewable Energy*, 35(2), 456 – 63, 2010.
- [112] Li Q.S., Liu D.K., Fang J.Q., and Tam C.M. "Multi-level optimal design of buildings with active control under winds using genetic algorithms." *Journal of Wind Engineering and Industrial Aerodynamics*, 86(1), 65 – 86, 2000.
- [113] Charron R., and Athienitis A.K. "Design and optimisation of net-zero energy solar homes." *ASHRAE Transactions*, 112 (2), 285 – 95, 2006.
- [114] Kilkis B.I. "An energy aware optimisation and control algorithm for sustainable building." *International Journal of Green Energy*, 1 (1), 65 – 77, 2004.
- [115] Diakaki C., Grigoroudis E., Kabelis N., Kolokotsa D., Kalaitzakis K., and Stavrakakis G. "A multi-objective decision model for the improvement of energy efficiency in buildings." *Energy*, doi:10.1016/j.energy.2010.05.012, 2010.
- [116] Bosch J.L., Lopez G., and Batlles F.J. "Daily solar irradiation estimation over a mountainous area using artificial neural networks." *Renewable Energy*, 33 (7), 1622 – 1628, 2008.
- [117] Cao J., and Lin X. "Application of the diagonal recurrent wavelet neural network to solar irradiation forecast assisted with fuzzy technique." *Engineering Applications of Artificial Intelligence*, 21, 1255 – 1263, 2008.

- [118] Zervas P.L., Sarimveis H., Palyvos J.A., and Markatos N.C.G. "Prediction of daily global solar irradiance on horizontal surfaces based on neural-network techniques." *Renewable Energy*, 33(8), 1796–803, 2008.
- [119] Mellit A., Kalogirou S.A., Shaari S., Salhi H., and Arab A.H. "Methodology for predicting sequences of mean monthly clearness index and daily solar radiation data in remote areas: Application for sizing a stand-alone PV system." *Renewable Energy*, 33(7), 1570–90, 2008.
- [120] Paul D., Mandal S.N., Mukherjee D., and Chaudhuri S.R.B. "Optimisation of significant insolation distribution parameters - A new approach towards BIPV system design." *Renewable Energy*, 35(10), 2182–91, 2010.
- [121] Kenisarin M., and Mahkamov K. "Solar energy storage using phase change materials." *Renewable and Sustainable Energy Reviews*, 11(9), 1913-65, 2007.
- [122] Kalogirou S.A. "Optimisation of solar systems using artificial neural-networks and genetic algorithms." *Applied Energy*, 77(4), 383-405, 2004.
- [123] Aronova E.S., Grilikhes V.A., and Shvarts M.Z. "Optimisation of arrangement of photoelectric power plants with radiation concentrators in solar electric power plant design." *Applied Solar Energy*, 44(4), 237-42, 2008.
- [124] Klychev S.I, Zakhidov R.A., Bakhrarov S.A., Dudko Y.A., and Khudoikulov A.Y. "Parameter optimisation for paraboloid-cylinder-receiver system of thermal power plants." *Applied Solar Energy*, 45(4), 281-4, 2009.
- [125] Garcia-Fernandez A., Zarza E., Valenzuela L., and Perez M. "Parabolic-trough solar collectors and their applications." *Renewable and Sustainable Energy Reviews*. 14(7). 1695–721, 2010.
- [126] Szargut J., and Stanek W. "Thermo-ecological optimisation of a solar collector." *Energy*, 32(4), 584–90, 2007.
- [127] Varun S. "Thermal performance optimisation of a flat plate solar air heater using genetic algorithm." *Applied Energy*, 87(5), 1793–9, 2010.
- [128] Chang Y.-P., and Ko C.-N. "A PSO method with nonlinear time-varying evolution based on neural network for design of optimal harmonic filters." *Expert Systems with Applications. An International Journal*, 36(3), 6809-16, 2009;
- [129] Zagrouba M., Sellami A., Bouaicha M., and Ksouri M. "Identification of PV solar cells and modules parameters using the genetic algorithms: Application to maximum power extraction. *Solar Energy*, 84(5), 860-6, 2010.
- [130] Marston A.J., Daun K.J., and Collins M.R. "Geometric optimisation of concentrating solar collectors using Monte Carlo simulation." *Journal of Solar Energy Engineering*, 132(4), 041002, 2010.
- [131] Mellit A., Kalogirou S.A., Hontoria L., and Shaari S. "Artificial intelligence techniques for sizing photovoltaic systems: A review." *Renewable and Sustainable Energy Reviews*, 13(2), 406-19, 2009.
- [132] Mellit A., Kalogirou S.A., and Drif M. "Application of neural networks and genetic algorithms for sizing of photovoltaic systems." *Renewable Energy*, 35(12), 2881-93, 2010.

- [133] Yang H., Lu L., and Zhou W. "A novel optimisation sizing model for hybrid solar-wind power generation system." *Solar Energy*, 81, 76-84, 2007.
- [134] Li C.-H., Zhu X.-J., Cao G.-Y., Sui S., and Hu M.-R. "Dynamic modelling and sizing optimisation of stand-alone photovoltaic power systems using hybrid energy storage technology." *Renewable Energy*, 34(3), 815-26, 2009.
- [135] Thiaux Y., Seigneurbieux J., Multon B., and Ahmed H.B. "Load profile impact on the gross energy requirement of stand-alone photovoltaic systems." *Renewable Energy*, 35(3), 602–13, 2010.
- [136] Kornelakis A., and Koutroulis E. "Methodology for the design optimisation and the economic analysis of grid-connected photovoltaic." *IET Transactions on Renewable Power Generation*, 3(4), 476–92, 2009.
- [137] Kornelakis A., and Marinakis Y. "Contribution for optimal sizing of grid-connected PV-systems using PSO." *Renewable Energy*, 35(6), 1333-41, 2010.
- [138] Cirre C.M., Berenguel M., Valenzuela L., and Klempous R. "Reference governor optimisation and control of a distributed solar collector field." *European Journal of Operational Research*, 193, 709–17, 2009.
- [139] Ammar M.B., Chaabene M., and Elhajjaji A. "Daily energy planning of a household photovoltaic panel." *Applied Energy*, 87(7):2340-51, 2010.
- [140] Piegari L., and Rizzo R. "Adaptive perturb and observe algorithm for photovoltaic maximum power point tracking." *IET Transactions on Renewable Power Generation*, 4(4), 317–32, 2010.
- [141] Fong K.F., Chow T.T., and Hanby V.I. "Development of optimal design of solar water heating system by using evolutionary algorithm." *Journal of Solar Energy Engineering*, 129(4), 499–501, 2007.
- [142] Kulkarni G.N., Kedare S.B., and Bandyopadhyay S. "Optimisation of solar water heating systems through water replenishment." *Energy Conversion and Management*, 50(3), 837-46, 2009.
- [143] Banos R., Manzano-Agugliaro F., Montoya F.G., Gil C., Alcayde A., and Gomez J. "Optimisation methods applied to renewable and sustainable energy: A review." *Renewable and Sustainable Energy Reviews*, 15, 1753-1766, 2011.
- [144] Kishor N., Saini R.P., and Singh S.P. "A review on hydropower plant models and control." *Renewable and Sustainable Energy Reviews*, 11, 776–96, 2007.
- [145] Anagnostopoulos J.S., and Papantonis D.E. "Optimal sizing of a run-ofriver small hydropower plant." *Energy Conversion and Management*, 48(10), 2663-70, 2007.
- [146] Pena R., Medina A., Anaya-Lara O., and McDonald J.R. "Capacity estimation of a mini-hydro plant based on time series forecasting." *Renewable Energy*, 34(5), 1204-9, 2009.
- [147] Yoo J.H. "Maximization of hydropower generation through the application of a linear programming model." *Journal of Hydrology*, 376(1–2), 182–7, 2009.
- [148] Hongling L., Chuanwen J., and Yan Z." A review on risk-constrained hydropower scheduling in deregulated power market." *Renewable and Sustainable Energy Reviews*, 12(5), 1465-75, 2008.

- [149] Ladurantaye D.D., Gendreau M., and Potvin J.-Y. "Optimizing profits from hydroelectricity production." *Computers and Operations Research*, 36(2), 499-529, 2009.
- [150] Kuby M.J., Fagan W.F., ReVelle C.S., and Graf W.L. "A multiobjective optimisation model for dam removal: An example trading off salmon passage with hydropower and water storage in the Willamette basin." *Advances in Water Resources*, 28(8), 845-55, 2005.
- [151] Amjady N., and Soleymanpour H.R. "Daily hydrothermal generation scheduling by a new modified adaptive particle swarm optimisation technique." *Electric Power Systems Research*, 80, 723-32, 2010.
- [152] Finardi E.C., Da Silva E.L., and Sagastizabal C. "Solving the unit commitment problem of hydropower plants via Lagrangian relaxation and sequential quadratic programming." *Computational and Applied Mathematics*, 24(3), 317-41, 2005.
- [153] Liu H., Jiang C., and Zhang Y. "Portfolio management of hydropower producer via stochastic programming." *Energy Conversion and Management*, 50, 2593-9, 2009.
- [154] Perez-Diaz J.I., Wilhelmi J.R., and Sanchez-Fernandez JA. "Short-term operation scheduling of a hydropower plant in the day-ahead electricity market." *Electric Power Systems Research*, 80(12), 1535-42, 2010.
- [155] Khanmohammadi S., Amiri M., and Haque M.T. "A new three-stage method for solving unit commitment problem." *Energy*, 35(7), 3072-80, 2010.
- [156] Fleten S.E., and Kristoffersen T.K. "Short-term hydropower production planning by stochastic programming." *Computers and Operations Research*, 35, 2656-71, 2008.
- [157] Lee T.Y. "Short term hydroelectric power system scheduling with wind turbine generators using the multi-pass iteration particle swarm optimisation approach." *Energy Conversion and Management*, 49(4), 751-60, 2008.
- [158] Li A., Wang L., Li J., and Ji C. "Application of immune algorithm-based particle swarm optimisation for optimized load distribution among cascade hydropower stations." *Computers and Mathematics with Applications*, 57, 1785-91, 2009.
- [159] Moeini R., Afshar A., and Afshar M.H. "Fuzzy rule-based model for hydropower reservoirs operation." *International Journal of Electrical Power and Energy Systems*, doi:10.1016/j.ijepes.2010.08.012, 2010.
- [160] Foong W.K., Maier H.R., and Simpson A.R. "Power plant maintenance scheduling using ant colony optimisation: an improved formulation." *Engineering Optimisation*, 40(4), 309-29, 2008.
- [161] Huang W., Murray C., Kraus N., and Rosati J. "Development of a regional neural network for coastal water level predictions." *Ocean Engineering*, 30(17), 2275-95, 2003.
- [162] Kazeminezhad M.H., Etemad-Shahidi A., and Mousavi S.J. "Application of fuzzy inference system in the prediction of wave parameters." *Ocean Engineering*, 32(14-15), 1709-25, 2005.
- [163] Reikard G. "Forecasting ocean wave energy: Tests of time-series models." *Ocean Engineering*, 36(5), 348-56, 2009.
- [164] Child B.F.M., Venugopal V. "Optimal configurations of wave energy device arrays." *Ocean Engineering*, 37(16), 1402-17, 2010.

- [165] Falcao A.F.O. “Stochastic modelling in wave power-equipment optimisation: Maximum energy production versus maximum profit.” *Ocean Engineering*, 31(11–12), 1407–21, 2004.
- [166] McCabe A.P, Aggidis G.A, and Widden M.B. “Optimizing the shape of a surge-and pitch wave energy collector using a genetic algorithm.” *Renewable Energy*. 35(12):2767–75; 2010.
- [167] Batten W.M.J., Bahaj A.S., and Molland A.F., Chaplin J.R. “Experimentally validated numerical method for the hydrodynamic design of horizontal axis tidal turbines.” *Ocean Engineering*, 34, 1013–20, 2007.
- [168] Lagorse J., Paire D., and Miraoui A. “Sizing optimisation of a stand-alone street lighting system powered by a hybrid system using fuel cell. PV and battery.” *Renewable Energy*, 34(3), 683–91, 2009.
- [169] Deshmukh M.K., and Deshmukh S.S. “Modelling of hybrid renewable energy systems.” *Renewable and Sustainable Energy Reviews*, 12, 235-49, 2008.
- [170] Kalantar S.M., and Mousavi G. “Dynamic behaviour of a stand-alone hybrid power generation system urbine, micro turbine, solar array and battery storage.” *Applied Energy*, 87(10), 3051–64, 2010.
- [171] Klychev S.I., Mukhammadiev M.M., Zakhidov R., and Potaenko K.D. “Technical and economic conditions for creation of combined solar-wind power plants.” *Applied Solar Energy*, 43(4), 214-7, 2007.
- [172] Moura P.S., and De Almeida A.T. “Multi-objective optimisation of a mixed renewable system with demand-side management.” *Renewable and Sustainable Energy Reviews*, 14(5), 1461-8, 2010.
- [173] Katsigiannis Y.A., Georgilakis P.S., and Karapidakis E.S. “Multiobjective genetic algorithm solution to the optimum economic and environmental performance problem of small autonomous hybrid power systems with renewables.” *IE Transactions on Renewable Power Generation*, 4(5), 404-19, 2010.
- [174] Mahor A., Prasad V., and Rangnekar S. “Economic dispatch using particle swarm optimisation: A review.” *Renewable and Sustainable Energy Reviews*, 13(8), 2134–41, 2009.
- [175] Brini S., Abdallah H.H., and Ouali A. “Economic dispatch for power system included wind and solar thermal energy.” *Leonardo Journal of Sciences*, 14, 204-20, 2009.
- [176] Bernal-Agustin J.L., Dufo-Lopez R., and Rivas-Ascaso D.M. “Design of isolated hybrid systems minimizing costs and pollutant emissions.” *Renewable Energy*, 31(14), 2227-44. 2006.
- [177] Dufo-Lopez R., and Bernal-Agustin J.L. “Multi-objective design of PV-wind-diesel hydrogen-battery systems.” *Renewable Energy*, 33(12), 2559-72, 2008.
- [178] Ould B., Sambou V., Ndiaye P.A., Kebe C.M.F., and Ndong M. “Optimal design of a hybrid solar-wind-battery system using the minimization of the annualized cost system and the minimization of the loss of power supply probability (LPSP).” *Renewable Energy*, 35(10), 2388-90, 2010.
- [179] Pachorl, A, and Suhane, P, “Modelling and simulation of photovoltaic/wind/diesel/battery hybrid power generation system Optimal design of a hybrid solar–wind-battery system” *Int. J. of Electrical, Electronics and Computer Engineering*, 3(1), 122 – 125, May 2014.

- [180] Montoya F.G., Banos R., Gil C., Espin A., Alcayde A., and Gomez J. "Minimization of voltage deviation and power losses in power networks using Pareto optimisation methods." *Engineering Applications of Artificial Intelligence*, 23:695-703, 2010.
- [181] Cormio C., Dicorato M., Minoia A., and Trovato M. "A regional energy planning methodology including renewable energy sources and environmental constraints." *Renewable and Sustainable Energy Reviews*, 7(2), 99-130, 2003.
- [182] Courtecuisse V., Sprooten J., Robyns B., Petit M., Francois B., and Deuse J. "A methodology to design a fuzzy logic based supervision of hybrid renewable energy systems." *Mathematics and Computers in Simulation*, doi:10.1016/j.matcom.2010.03.003, 2010.
- [183] Kaviani A.K., Riahy G.H., and Kouhsari S.H.M. "Optimal design of a reliable hydrogen based stand-alone wind/PV generating system, considering component outages." *Renewable Energy*, 34(11), 2380-90, 2009.
- [184] Eke R., Kara O., and Ulgen K. "Optimisation of a wind/PV hybrid power generation system" *International Journal of Green Energy*, 2(1), 57-66, 2005.
- [185] Giannakoudis G., Papadopoulos A.I., Seferlis P., and Voutetakis S. On the systematic design and optimisation under uncertainty of a hybrid power generation system using renewable energy sources and hydrogen storage. *Computer Aided Chemical Engineering*, 28, 907-12, 2010.
- [186] Sreeraj E.S., Chatterjee K., and Bandyopadhyay S. "Design of isolated renewable hybrid power systems." *Solar Energy*, 84(7), 1124-36, 2010.
- [187] Bernal-Agustin J.L., and Dufo-Lopez R. "Simulation and optimisation of standalone hybrid renewable energy systems." *Renewable and Sustainable Energy Reviews*, 13, 2111-8, 2009.
- [188] Senjyu T., Hayashi D., Yona A., Urasaki N., and Funabashi T. "Optimal configuration of power generating systems in isolated island with renewable energy." *Renewable Energy*, 32(11), 1917-33, 2007.
- [189] Balamurugana P., Ashok S., and Jose T.L. "Optimal operation of biomass/wind/PV hybrid energy system for rural areas." *International Journal of Green Energy*, 6(1), 104-16, 2009.
- [190] Nema P., Nema R.K., and Rangnekar S. "A current and future state of art development of hybrid energy system using wind and PV-solar: A review." *Renewable and Sustainable Energy Reviews*, 13(8), 2096-103, 2009.
- [191] Dufo-Lopez R., Bernal-Agustin J.L., and Contreras J. "Optimisation of control strategies for stand-alone renewable energy systems with hydrogen storage." *Renewable Energy*, 32(7), 1102-26, 2007.
- [192] Garcia R.S., and Weisser D. "A wind-diesel system with hydrogen storage: Joint optimisation of design and dispatch." *Renewable Energy*, 31(14), 2296-320, 2006.
- [193] Koutroulis E., Kolokotsa D., Potirakis A., and Kalaitzakis K. "Methodology for optimal sizing of stand-alone photovoltaic/wind-generator systems using genetic algorithms." *Solar Energy*, 80(9), 1072-88, 2006.
- [194] Yang H., Zhou W., Lu L., and Fang Z. "Optimal sizing method for stand-alone hybrid solar-wind system with LPSP technology by using genetic algorithm." *Solar Energy* 82(4), 354-67, 2008.
- [195] Del Real A.L., Arce A., and Bordons C. "Optimisation strategy for element sizing in hybrid power systems." *Journal of Power Sources* 2009, 193(1), 315-21, 2009.

- [196] Bernal-Agustin J.L., Duflo-Lopez R. "Efficient design of hybrid renewable energy systems using evolutionary algorithms." *Energy Conversion and Management*, 50(3), 479-89, 2009.
- [197] Zervas P.L., Sarimveis H., Palyvos J.A., and Markatos N.C.G. "Model-based optimal control of a hybrid power generation system consisting of photovoltaic arrays and fuel cells." *Journal of Power Sources*, 181(2), 327-38, 2008.
- [198] Diaf S., Belhamel M., Haddadi M., and Louche A. "Technical and economic assessment of hybrid photovoltaic/wind system with battery storage in Corsica island." *Energy Policy*, 36(2), 743-54, 2008.
- [199] Hakimi S.M., and Moghaddas-Tafreshi S.M. "Optimal sizing of a stand-alone hybrid power system via particle swarm optimisation for Kahnouj area in south-east of Iran." *Renewable Energy*, 34(7), 1855-62, 2009.
- [200] Razak J.A., Sopian K., Ali Y., Alghoul M.A., Zaharim A., Ahmad I. "Optimisation of PVwind-hydro-diesel hybrid system by minimizing excess capacity." *European Journal of Scientific Research*, 25(4), 663-71, 2009.
- [201] Chakraborty S., Senjyu T., Saber A.Y., and Funabashi T. "Optimal thermal unit commitment integrated with renewable energy sources using advanced particle swarm optimisation." *IEEE Transactions on Electrical and Electronic Engineering*, 4, 609-17, 2009.
- [202] Matevosyan J., Olsson M., and Soder L. "Hydropower planning coordinated with wind power in areas with congestion problems for trading on the spot and the regulating market." *Electric Power Systems Research*, 79 (1), 39-48, 2009.
- [203] Castronuovo E.D, and Lopes JAP. "On the optimisation of the daily operation of a wind-hydro power plant." *IEEE Transactions on Power Systems*, 19 (3), 1599-606, 2004.
- [204] Jurado F., and Saenz J.R. "Neuro-fuzzy control for autonomous wind-diesel systems using biomass." *Renewable Energy*, 27 (1), 39-56, 2002.
- [205] Duflo-Lopez R., Bernal-Agustin J.L. "Design and control strategies of PV-diesel systems using genetic algorithms." *Solar Energy*, 79 (1), 33-46, 2005.
- [206] Anagnostopoulos J.S., and Papantonis D.E. "Simulation and size optimisation of a pumped-storage power plant for the recovery of wind-farms rejected energy." *Renewable Energy*, 33 (7), 1685-94, 2008.
- [207] Anarbaev A.I., Zakhidov R.A., and Avezov R.R. "Schematic and parametric optimisation of solar and fuel boiler installations." *Applied Solar Energy*, 44(1), 20-3, 2008.
- [208] Abeer A.M., Shawky H., Maged N.F and Ramadan S.G., "Modelling and Simulation for Hybrid of PV-Wind System," *International Journal of Engineering Research*, vol. 4, no. 4, pp. 178- 183, Apr. 2015.
- [209] Tina, G., Gagliano S., and Raiti S., "Hybrid solar/wind power system probabilistic modelling for long term performance assessment." *Solar Energy*, 80, 578-588.
- [210] IEA renewable energies for remote areas and islands, April, 2012.
- [211] Yen H. and Su-yin L. "Economic analysis and optimal energy management models for microgrid systems. A case study in Taiwan." *Applied Energy*, 103, 145-154, 2013.
- [212] Wies S.W., Johnson R.A. and Chubb T.J. "Simulink model for economic analysis and environmental impacts of a PV with diesel-battery system for remote villages power system." *IEEE Transactions*, 20 (2), 692-700 11, 2010.

- [213] Collares-Pereira, M. and Rabl, “The average distribution of solar radiation correlation between diffuse and hemispherical and between daily and hourly insolation values.” *Solar Energy*, 22, 155-164.
- [214] Tina G., Gagliano S., and Raiti S. “Hybrid solar/wind power system probabilistic modelling for long term performance assessment.” *Solar Energy*, 80, 578-588.
- [215] Celik, A.N. “Techno-economic analysis of autonomous PV-wind hybrid energy systems using different sizing methods”, *Energy Conversion and Management*, 44, 1951-1968, 2003.
- [216] Panwara N.L., Kaushik S.C., and Surendra K., “Role of Renewable and Sustainable Energy Reviews” vol. 15, pp. 1513- 1524, Jan 2011.
- [217] Bakos, G.C., and Tsagas, N.F. “Techno economic assessment of a hybrid solar/wind installation for electrical energy saving.” *Energy and Buildings*, 35(2), 139-45, 2003.
- [218] Chen H., and Cong T.N. “Progress in electrical energy storage system: A critical review.” *Prog Nat Sci.*, 19, 291-312, 2009.
- [219] European Commission. “The future role and challenge of energy storage” In: DG ENER work Pap, 18; 2013.
- [220] Ma T., Yang H., Lu L., and Peng J. “Technical feasibility on a standalone hybrid solar – wind system with pumped hydro storage for a remote island in Hong Kong”. *Renewable Energy*, 69, 7-15, 2014.
- [221] Aihara R., Yokoyama A., and Nomiya F. “Impact of operational scheduling of pumped storage power plant considering excess energy and reduction of fuel cost on power supply reliability in a power system with a large penetration of photovoltaic generations.” *Power System Technology (POWERCON) International Conference*, pp. 1- 8, 2011.
- [222] Padron S., Medina J.F., and Rodriguez A. “Analysis of a pumped storage system to increase the penetration level of renewable energy in isolated power systems. Gran Canaria: a case study on energy.” *Energy*, 53-62, 2011.
- [223] Zhang S., and Xia X. “Optimal control of operation efficiency of belt conveyor system,” *Applied Energy*, 1929-1937; 2010.
- [224] Xia X., Zhang J., and Elaiw A. “An application of model predictive control to the dynamic dispatch of power generation.” *Control Eng. Practice*, 19, 638-48, 2011.
- [225] Bemporad A., Borrelli F., and Morari M. “Model predictive control based on linear programming: The explicit solution.” *IEEE Trans. Autom Control*, 47, 2002.
- [226] Henerica T. Bing Z. and Xiaohua “ Switched model predictive control for energy dispatching of a photovoltaic –diesel –battery hybrid power System” *IEEE Transactions on Control System Technology*, vol. 23, no. 3 pp 1229 – 1236, May 2015.
- [227] Lalor G., Mullane A., and O'Malley M. “Frequency control and wind turbine technologies.” *IEEE Trans Power Syst*, 20, 1905–13, 2005.
- [228] ENTSO-E. “Operational handbook; policies; load-frequency control and performance” available online: <https://www.entsoe.eu/>; 2009 accessed 26.04.2013.

