

**THE DEVELOPMENT AND EVALUATION OF A RADIO  
FREQUENCY IDENTIFICATION BASED CATTLE HANDLING  
SYSTEM**

**T J Mutenje**

Submitted in fulfilment of the requirements for the degree of MSc Eng

School of Engineering  
University of KwaZulu-Natal  
Pietermaritzburg

January 2013

## DECLARATION

I Tendai Justin Mutenje declare that;

- (i) The research reported in this dissertation/thesis, except where otherwise indicated, is my original work.
- (ii) This dissertation/thesis has not been submitted for any degree or examination at any other university.
- (iii) This dissertation/thesis does not contain other persons' data, pictures, graphs or other information, unless specifically acknowledged as being sourced from other persons.
- (iv) This dissertation/thesis does not contain other persons' writing, unless specifically acknowledged as being sourced from other researchers. Where other written sources have been quoted, then:
  - a) their words have been re-written but the general information attributed to them has been referenced;
  - b) where their exact words have been used, their writing has been placed inside quotation marks, and referenced.
- (v) Where I have reproduced a publication of which I am an author, co-author or editor, I have indicated in detail which part of the publication was actually written by myself alone and have fully referenced such publications.
- (vi) This dissertation/thesis does not contain text, graphics or tables copied and pasted from the Internet, unless specifically acknowledged, and the source being detailed in the dissertation/thesis and in the References sections.

Signed: \_\_\_\_\_

## ACKNOWLEDGEMENTS

The author wishes to record his sincere appreciation for the assistance given by the following:

Professor J.C. Smithers, former Head of the School of Bioresources Engineering and Environmental Hydrology, University of KwaZulu Natal, for the supervision of this project and for providing his invaluable assistance, guidance and support throughout the duration of this project, without which it would have not been possible to complete.

Professor T.E. Simalenga, Research Institute Manager of the Agricultural Research Council's Institute for Agricultural Engineering, for assistance, support, invaluable advice and co-supervising this project.

Mr P.J. Britz, Programme Manager at the Agricultural Research Council's Institute for Agricultural Engineering, for assistance and support on engineering design principles.

Mr J.G. van Gass, Manager at Limpopo Department of Agriculture, for his invaluable advice on the structural design requirements for the cattle handling facilities and engineering principles of conceptual design.

Mr C. Challis, Mr K. McCaull, Mr G. Ward and Mr G. Talbot, Directors at Axxon Pty, Tru-Test, Pratley Systems and Taltec respectively, for their invaluable advice on cattle automation control, electronics, systems design, fabrication and evaluation procedures.

The Agricultural Research Council's Institute for Agricultural Engineering (ARC-IAE) for funding this project and Researchers Miss K.I. Maroo, Mr T. Mavundza and Mr M. Mamabolo for their assistance throughout the research.

My family, wife and children for their encouragement and moral support during my studies.

## **ABSTRACT**

Manual cattle handling systems are widely used in South Africa. A literature review and consultations were conducted with both producers and equipment manufactures, to assess the advantages and disadvantages of various cattle handling systems with the objective of developing a more efficient system that incorporates automation, electronics and Radio Frequency Identification (RFID) technology. In this study an automated, selective sorting (RFID) based cattle handling system was developed and assessed as an alternative to the widely adopted conventional manual management system practiced in South Africa. The system is still under research and not yet available on the market.

This document describes the research and development process undertaken which included planning, literature review, consultation, design, fabrication, evaluation and discussions. The RFID based system developed consists of manual, semi- and fully automated components in the form of a neck-body clamp with through access, flow control double split gates and a weigh-identification-sort system. For the ease of comparison the system was developed with a manual by-pass as a control to compare the automated and manual systems in terms of establishment cost, handling duration including identification, weighing and sorting, and operator and animal stress levels which impact on business profitability and system efficiency. Both the manual by-pass and automated RFID-based systems were evaluated.

The automated system resulted in reduced handling duration, operational costs and handling stress on both operator and the animal whilst enabling selective automated sorting. The infrastructure was designed to have a capacity to handle 500 animals per day with 5 handlers and a capital investment of R200 000 was required with an operational cost of R25 000 per month.

After incorporating RFID, electronics and automation of the system it was established that, on average, cattle handling duration was reduced by 63%, incorrect sorting was

reduced by 5.5%, man hours were reduced by 70% with 23% and 14% less fatigue and stress levels to the handler and the animals respectively, whilst achieving efficient selective sorting. A cost benefit analysis was undertaken for both systems with the aim of assessing and determining the most profitable system. An assumption was made that the cash flow pattern remains uniform for both systems over the entire evaluation period. This revealed that the introduction of RFID based technology as an alternative to a manual based system results in an increase in business profitability by 20% and shorten the payback period by 5 years. Although there is still need to further investigate the performance parameters under different environments, it can be concluded that the introduction of RFID, electronics and automation improves the overall system technical efficiency by 32% whilst enabling efficient selective handling.

## TABLE OF CONTENTS

	Page
DECLARATION .....	i
ACKNOWLEDGEMENTS .....	ii
ABSTRACT .....	iii
TABLE OF CONTENTS .....	v
LIST OF FIGURES .....	viii
LIST OF TABLES .....	x
1. INTRODUCTION.....	1
2. REVIEW OF MANUAL AND RFID BASED CATTLE SYSTEMS .....	6
2.1 Cattle Feedlots .....	6
2.2 Handling Facility for Cattle.....	6
2.2.1 Cattle Weighing System.....	7
2.2.2 Tagging and Identification .....	7
2.2.3 Cattle Sorting .....	8
2.2.4 Feeding and Dipping System .....	10
2.2.5 Challenges of Stress and Fatigue in Conventional Handling.....	10
2.3 Electronic RFID Cattle Management Systems.....	11
2.3.1 Reading of Electronic Identifiers and Control Interfaces .....	12
2.3.2 Applicability and Performance of Electronic Management.....	13
2.3.3 Comparison between Electronics Tags and Rumen Boluses .....	14
2.4 Case Studies of RFID Technology Implementation for Cattle Handling.....	15
2.4.1 Application of RFID Tags for Cattle Management.....	15
2.4.2 Animal Identification, Weighing and Auto-sorting Applications.....	16
2.4.3 Case Study of a Total Management System .....	18
2.5 Summary of System Performance .....	19
2.5.1 Characteristics of a Standard Design Handling System.....	20
2.5.2 Comparison of Manual and RFID Systems .....	20
2.5.3 Cost Benefit Analysis.....	23
2.5.4 Statistical Methods Used to Substantiate Benefits.....	25
2.5.5 Need Statement for South African Feedlots Systems .....	25

2.6	Design Problem Areas .....	26
3.	CONCEPTUAL DESIGN AND METHODOLOGY .....	28
3.1	Funder's System Requirements .....	28
3.2	Selection Considerations .....	29
3.2.1	Forward Velocity .....	29
3.2.2	Lighting in Sorting Facilities .....	30
3.2.3	Learning and Adaptation in Cattle .....	30
3.3	Concept Design and Methodology Summary.....	30
4.	DESIGN OF AN AUTOMATED CATTLE HANDLING SYSTEM.....	31
4.1	Standard Design Procedures.....	31
4.2	System Prototype Development .....	31
4.3	Box Shaped Cattle Crush Design .....	32
4.3.1	Design Problems in Existing Box Shaped Cattle Crush Systems .....	33
4.3.2	Final Specifications and Detailed Design .....	33
4.4	Cattle Flow Control Design.....	36
4.4.1	Design Problems in the Existing Manual Systems .....	37
4.4.2	Design Solutions .....	37
4.5	Cattle Sliding Gates System Design.....	38
4.5.1	Design Problems in the Existing Manual Systems .....	38
4.5.2	Design and Final Specifications.....	39
4.6	Identification and Weigh Box Design .....	40
4.6.1	Design Problems in the Existing Manual Systems .....	40
4.6.2	Detailed Design and Final Specifications .....	40
4.7	Cattle Restraining System Selection .....	42
4.7.1	Design Problems in the Existing Manual Systems .....	42
4.7.2	Selection Criteria for the Restraining System.....	42
4.8	Handler Access Gate Design .....	43
4.8.1	Specification Requirements for the Handler Access Gates.....	44
4.8.2	Selection Consideration for the Handler Access Gates.....	44
4.9	Automated Cattle Sorting System Design.....	45
4.9.1	Specification Requirements for the Cattle Sorting System.....	45
4.9.2	Selection Consideration and Computations .....	46

4.10	Proposed Complete System Development and Evaluation Procedure .....	47
4.11	Summary of the System Development Process and Way Forward .....	48
5.	SYSTEM FABRICATION AND EVALUATION PROCESS .....	49
5.1	Design Modification Prior to Fabrication .....	49
5.1.1	Layout Design Modification .....	50
5.1.2	Handler Access Gates .....	52
5.1.3	Flow Control Gate Design Modification .....	54
5.1.4	Identification and Weigh Box Design Modification .....	55
5.1.5	Automatic Sorting Gates Design Modification .....	57
5.1.6	Ergonomics Evaluation .....	59
5.2	Complete Fabricated and Constructed Infrastructure .....	60
6.	EVALUATION PROCEDURES AND OUTCOMES .....	63
6.1	Handling Duration Determination .....	64
6.2	Determination of Stress and Fatigue Levels .....	65
6.3	Accuracy of the Cattle Sorting System .....	66
6.4	System Efficiency Determination .....	66
6.5	Evaluation of the System .....	69
6.6	Challenges and Solutions .....	70
6.7	Results .....	71
6.7.1	Sorting Accuracy .....	74
6.7.2	Work Physiology .....	75
6.7.3	Stress Levels Analysis .....	77
6.7.4	Summary of Results .....	79
6.8	Cost-Benefit Analysis for RFID Based Technology Introduction .....	81
7.	DISCUSSION AND CONCLUSIONS .....	85
8.	REFERENCES .....	89
9.	APPENDIX A: COMPLETE HANDLING SYSTEM DESIGN NOTES .....	101
10.	APPENDIX B: DEVELOPED VIRTUAL DESIGN DRAWINGS .....	102
11.	APPENDIX C: MODIFIED DRAWINGS FOR CONSTRUCTION .....	109
12.	APPENDIX D: CONSTRUCTED CATTLE HANDLE SYSTEM .....	115
13.	APPENDIX E: EVALUATION PROCESS AND OUTPUT DATA .....	116



## LIST OF FIGURES

	Page
Figure 2.1 Typical working area (Breedt, 2003) .....	8
Figure 2.2 Typical sorting gates leading from clamp (Boontech, 2010).....	9
Figure 2.3 Transponders in (a) rumen boluses and (b) ear tags (IDEA, 2003) .....	11
Figure 2.4 Examples of stationary reader panels (IDEA, 2003) .....	12
Figure 2.5 Sorting unit making us of RFID technology (INRA, 2009) .....	18
Figure 2.6 Standard conventional cattle handling system layout (Mutenje, 2010b) ....	26
Figure 4.1 Basic standard design procedure (SABS Standards, 2010d) .....	31
Figure 4.2 Schematic diagram of the RFID based cattle handling system.....	32
Figure 4.3 Pictorial view of the proposed box shaped crush.....	36
Figure 4.4 Flow control double split gates .....	38
Figure 4.5 Cattle sliding gates system .....	40
Figure 4.6 Cattle identification and weigh box .....	42
Figure 4.7 Photo of a neck and body clamp (Longhorn, 2010).....	43
Figure 4.8 Rendered drawing of the handler access gates.....	45
Figure 4.9 Automated pneumatic cattle sorting system .....	47
Figure 5.1 Revised layout of infrastructure .....	50
Figure 5.2 Final modified design of cattle lead alley passageway .....	51
Figure 5.3 Views of the modified restraining system adopted (Taltec, 2010) .....	52
Figure 5.4 Final modified design of the handler access gates .....	53
Figure 5.5 Operational handler access gate with cattle in alleyway.....	53
Figure 5.6 Final modified design of the flow control double split gates.....	54
Figure 5.7 Flow control double split gates with automation and air control.....	55
Figure 5.8 Final modified design of the identification weighing box assembly .....	56
Figure 5.9 ID-Weigh box modifications and fabricated outcome .....	57
Figure 5.10 Final modified design of the automated sorting system .....	58
Figure 5.11 Automated sorting gates modification and fabrication outcomes.....	58
Figure 5.12 Modified Polar Sport Tester-Profi utilised for cattle stress measurement.	59
Figure 5.13 Polar Sport Test Heart-rate Monitor used for human exertion monitoring.	60
Figure 5.14 Complete portable, automated RFID based animal handling system .....	61

Figure 6.1	Average handling duration per animal for evaluations on Day 3 .....	71
Figure 6.2	Average handling duration per animal for evaluations on Day 6 .....	71
Figure 6.3	Average handling duration per animal for evaluations on Day 10 .....	72
Figure 6.4	Total handling durations for the 10 days .....	72
Figure 6.5	Significance test results extract from Graph Pad InStat software.....	74
Figure 6.6	Averaged daily number of incorrectly sorted animals for the two systems	75
Figure 6.7	Initial input capital requirement for each system.....	80
Figure 6.8	Total cost of cardiac work for the systems .....	80
Figure 6.9	Overall technical efficiencies of the systems .....	81
Figure 10.1	Box shaped crush detailed design drawing.....	103
Figure 10.2	Flow Control double split gates design drawing.....	104
Figure 10.3	Automated sliding gates design drawing .....	105
Figure 10.4	ID-weigh box design drawing.....	106
Figure 10.5	Handler access gates design drawing.....	107
Figure 10.6	Automated sort gates design drawings.....	108
Figure 11.1	Modified alley passageway for cattle flow into restraining system.....	110
Figure 11.2	Modified handler access gates .....	111
Figure 11.3	Modified flow control double split gates .....	112
Figure 11.4	Modified RFID identification-weigh box .....	113
Figure 11.5	Modified automated three way cattle sorting system.....	114
Figure 12.1	Complete constructed RFID based automated cattle handling system.....	115
Figure 13.1	Significance test results extract from Graph Pad InStat software.....	120
Figure 13.2	Significance test for heart rate results obtained .....	121
Figure 13.3	Significance test for energy expenditure of the two systems.....	122
Figure 13.4	Significance test for total cardiac cost of work of the two systems.....	123
Figure 13.5	Significance test for physiological cost of work of the two systems .....	124
Figure 13.6	Significance test for cattle breathing frequency for the two systems .....	125
Figure 13.7	Significance test for cattle heart rate for the two systems.....	126

## LIST OF TABLES

	Page
Table 2.1 Rumen bolus and electronic tags comparison (Erasmus <i>et al.</i> , 1999) .....	14
Table 2.2 Performance limitations of the two handling systems (Grandin, 1994).....	21
Table 2.3 Benefits of incorporating RFID technology in animal handling systems ....	22
Table 2.4 Cost benefit analysis focus areas (Levitan, 2010).....	23
Table 2.5 Selected cost benefit analysis methods (Levitan, 2010).....	24
Table 2.6 Design problem areas of the cattle handling system (Naas, 2002) .....	27
Table 3.1 Concept and specification principles of the proposed system.....	29
Table 4.1 Problems in the existing box shaped crush systems.....	33
Table 5.1 End-user design modification requirements.....	49
Table 5.2 Handler access gates modifications.....	52
Table 5.3 Flow control double split gates modifications .....	54
Table 5.4 ID-Weigh box design modifications .....	56
Table 5.5 Automated sorting gates modification and fabrication outcomes .....	57
Table 5.6 Contributors to infrastructure development and evaluation.....	62
Table 6.1 Details of evaluation site .....	63
Table 6.2 Handling duration parameters .....	64
Table 6.3 Sorting categories schedules and directions.....	66
Table 6.4 Physiological workload classification (Varghese <i>et al.</i> , 1994) .....	67
Table 6.5 Equations for system technical efficiency (Jandrow <i>et al.</i> , 1982).....	69
Table 6.6 Intervention employed to address system limitations during evaluation ....	70
Table 6.7 Average handling duration for both systems.....	73
Table 6.9 Characteristics of the handlers monitored .....	75
Table 6.10 Handler workload classification in manual cattle handling .....	76
Table 6.11 Handler workload classification in automated cattle handling .....	76
Table 6.12 Work physiology analysis between manual and automated systems.....	77
Table 6.13 Estimated and Day 10 stress levels in cattle for the two systems .....	78
Table 6.14 Estimated and Day 10 stress levels from heart rate monitoring.....	78
Table 6.15 Summary of results of the system evaluation process.....	79
Table 6.16 Considerations given in feedlot operations (Grandin, 2003) .....	82

Table 6.17 Cost benefit analysis between RFID and manual based support systems ....	83
Table 6.18 Payback period comparison table .....	84
Table 9.1 Contents of Appendix A: System design notes .....	101
Table 10.1 Contents of Appendix B: Virtual prototype outputs .....	102
Table 11.1 Contents of Appendix C: Modified drawing of the developed system .....	109
Table 13.1 System evaluation process data collection form .....	116
Table 13.2 Day 3 average handling duration results .....	117
Table 13.3 Day 6 average handling duration results .....	117
Table 13.4 Day 10 average handling duration results .....	117
Table 13.5 Sessional total handling duration for the developed system .....	118
Table 13.6 Handler work physiology data obtained from systems evaluation.....	118
Table 13.7 Cattle work physiology data obtained from systems evaluation .....	119

# 1. INTRODUCTION

Handling animals efficiently and speedily as possible is of paramount importance for profitable management of beef cattle in production systems (Anderson *et al.*, 2005). This has been found to minimise handling duration and stress levels to both cattle and operator (Grandin, 2010). According to Ewbank and Parker (2007), cattle are handled for various reasons including; production operations, health issues and transport for marketing.

Nowers and Welgemoed (2010) highlight and confirm Shackleton's (1993) findings that cattle are generally finished for market on natural veld, permanent pastures, intensive animal housing facilities or in intensive feeding systems called feedlots. Grandin (1994) defines a feedlot as a closed and intensive feeding system for finishing beef cattle before slaughter. Mapiye *et al.* (2007) highlights low production levels in extensive production systems and suggests further investigation into a more intensive production strategy. Veld grazing is discouraged and Cordova and Wallace (1978) highlight overgrazing as the major cause of desertification of rural land in South Africa. In an institutional context to cattle development in Southern Africa, Vink (1987) report that there is a need to adopt more intensive production strategies in South Africa as are being utilised in more developed countries for livestock production systems. For example, researchers from the Nebraska Lincoln Animal Production Institute in the USA have shown that intensive beef cattle feedlot system adoption has increased productivity by 50% (Anderson *et al.*, 2005). Thus, intensive cattle feedlot systems can be considered the most appropriate measure to ensure sustainability of animal production operations in developing countries (Erickson, 2010). Subak (1999) concluded from research into the global environmental cost of beef production that the world needs to migrate to intensive feedlot systems as opposed to extensive veld grazing which is associated with overgrazing and poor productivity. This sentiment is also shared by Anderson *et al.* (2005) who evaluated the efficiency of beef cattle production systems and concluded that intensive feedlot systems are 60% more productive in terms of profitability than extensive veld grazing systems.

In a feedlot system animals gain on average 2.5-3% of body mass per day which translates into approximately 1 kg per day (Grandin, 2010). A feedlot comprises of pens and infrastructure for animal handling where management practices such as identification, sorting, feeding and dipping are performed (Grandin, 2003). Ligthelm and van Wyk (1985) encourages and emphasise that to ensure sustained profitability of a feedlot operation there is a need to continuously review and develop better management practices to ensure more efficient handling systems.

According to the South African Feedlot Association (SAFA, 2010), there are approximately 70 commercially viable feedlots in South Africa which account for 75% - 85% of all the beef produced in the country. The Census for Commercial Agriculture (CCA, 2010) reported that there are approximately 12 large feedlots comprising of more than 20 000 cattle and more than 50 small to medium sized feedlots with less than 2000 cattle. It is in these systems, where better management practises are thought to improve profitability (SAFA, 2010). According to Nowers and Welgemoed (2010), feedlot operations are either manual or automated depending on the owner preference, technology available or affordability. They further indicated that from research conducted in the USA, it has been realised that automation has increased system efficiency, through improved animal identification, weighing and sorting, which reiterates findings by Borg (1993). Strydom *et al.* (2008) highlighted that 95% of feedlots in South Africa are manually operated with little or no automation and thus rely on human accuracy for their management and production practices. Conversely, in many EU countries only 15% are manually operated, whilst manually operated systems make up less than 5% in countries like Australia and New Zealand (Fatcow, 2010.). Manually based feedlot systems have been highlighted as the major cause of low system efficiencies in South African feedlots and there is thus a need to investigate the applicability of automation for improved cattle production systems in South Africa (Galyean *et al.*, 2010). Butchbaker *et al.* (1999) also highlight the importance to review and improve current management practices in animal handling facilities in South Africa as improvements may increase both the profitability and the efficient running of the enterprises.

Nowers and Welgemoed (2010) state that the lower profit margins of most South African feedlots in the size range of 4000 or less cattle are mainly as a result of current management practices. They further identified the shortcomings of conventional manual management systems such as long animal handling duration, handling errors, low standards of record keeping, limited consideration of animal welfare and poor sorting systems when selecting animals for marketing. Lambooij and Merks, (1989) indicated that the use of electronic and automated technology would be a more desirable alternative to improve handling operations as practiced in many developed countries. According to Lambooij and Merks (1989), the technology of electronic cattle management can be utilised in recording animal data and animal identification for good farm practices. From research and evaluations conducted in Dublin; it was found that electronic cattle management results in improved data management reduced animal handling time and enabled easy planning of animal handling activities (Lambooij and Merks, 1989).

Taking into considerations the global increase in Precision Livestock Farming (PLF), designers are increasingly adopting electronic management systems using Radio Frequency Identification (RFID) and automated feedlot systems (ATL, 2010). The adoption of RFID based infrastructure is increasing in the developed world as they result in improved cattle handling. South African is lagging behind in the adoption of PLF, and hence there is a need to investigate the applicability of such technology locally (Strydom *et al.*, 2008).

Researchers from many developed countries have highlighted the benefits of developing and adoption of RFID based technologies that improve system operations. With the introduction of RFID based technology in cattle operations, Naas (2002) report a reduction in labour cost, whilst Artman (1999) found a reduction of incorrect readings from 6% to 0.1% and Geers (1997) anticipated that the use of RFID would provide possibilities such as automatic sorting, feeding and health treatments. Trovan (2009) report a 60% faster handling with RFID based systems with consequently less stress on the animals and time saving in the operations. Dairymaster (2009) also report a reduction in labour costs where the manpower required reduced from 13 to 6

labourers and one operator could milk 800 cows in a period of 3.5 hours compared to manually managed systems where only 350 cows were handled for the same duration. INRA (2009) reports the development and testing of RFID based technologies which was able to sort an average of 700 ewes in 20 minutes, which was 80% faster than manual sorting, resulting in a reduction of an equivalent of almost 200 labour hours per week. Cox *et al.* (2006) observed a labour force reduction of almost 50% and reduced data recording errors by almost 5% when RFID technologies were introduced. It was also observed that this management practice reduced sorting time by 3 to 4 h per day for 500 cattle, which in turn resulted in reduced animal stress and worker fatigue, thus increasing the profit margins for the operation.

In order to investigate the applicability of RFID for the improved operation of cattle feedlot systems in cattle handling systems in South Africa, a project was commissioned by the Agricultural Research Council's Institute for Agricultural Engineering (ARC-IAE). This study resulted from and was funded by the commissioned project.

The aim of this project was to design and develop an animal handling system that incorporates RFID technology in order to improve cattle handling systems and to facilitate improved operation and management of feedlots in South African. The objectives of this study were to:

- to investigate the limitations in the current conventional management practices being utilised in South African feedlots,
- to review, through the use of case studies and experience from other countries, the benefits of incorporating RFID technology in animal management systems,
- to develop an automated, selective sorting RFID based cattle handling system that could be utilised as an alternative to the widely adopted conventional manual management practices widely used in South Africa, and
- to assess and compare the performance of the conventional and automated, selective sorting RFID based cattle handling system in terms of handling duration, operational costs and handling stress.



If the research findings from studies conducted in other countries are applicable in South Africa, it was hypothesised that the incorporation of automated RFID based technology into a cattle handling system would translate into an increase in overall system efficiency and business profitability. This document describes the research and development process which included planning, literature review, consultation, design, fabrication and evaluation.

Chapter 2 contains a literature review of the conventional cattle management system currently being utilised in the South African feedlot industry. It describes its limitations and how automated RFID technology has improved operations in other countries.

Chapter 3 contains details on the basic design problems in handling systems and how they can be addressed through the introduction of technology for improved handling identification and selection. Different approaches to the problem are discussed and the design problem is divided into three basic systems, i.e. flow control, identification and sorting systems.

Chapter 4 contains the detailed design procedures derived from literature, consultations and computation until the final specification was developed. Sections also contain virtual prototypes of the end product for visualisation prior to fabrications of the designs. With the aid of the virtual prototypes produced for the entire system, researchers from the ARC-IAE were able to give their own assessment of the developed system and identified the issues which required further attention.

Detailed fabrication, construction and evaluation processes are summarised in Chapter 5. This chapter contains procedural system development, construction, and both workshop and site evaluation. The outcomes of the evaluation process are also contained in this chapter followed by brief discussions of the findings.

Chapter 6 contains discussion of the project and a summary of conclusions made, while Chapter 7 contains a list of references used in the study.

## **2. REVIEW OF MANUAL AND RFID BASED CATTLE SYSTEMS**

This chapter contains a literature review of the performance parameters of manual cattle management in South Africa and a comparative analysis between conventional and automated RFID based technology used in other countries.

### **2.1 Cattle Feedlots**

According to Breedt (2003), construction of cattle feedlots should be on a slope of between 3-6% and is a function of the soil type, prevailing winds, possible future extensions and space for pollution control dams. Grandin (1999) indicated that a typical layout consists of feedlot pens where the animals are kept, handling facilities where management practices are performed, a unit for storing and processing feed, an office and workshop area, and manure, waste and drainage handling structures. A feedlot should also include facilities for staff and business operations (Meuling, 2006).

### **2.2 Handling Facility for Cattle**

Grandin (2004) defines a handling facility as the area where the cattle are initially received into the feedlot system. Collyer and Viljoen (2003) highlighted that under the current manual management practices, once the animals are received, the following sequential activities of weighing, tagging and dehorning, sorting, dipping and inoculation are conducted prior to release to the holding pens. The handling facilities comprise of the following basic handling zones: leader crush, weighing area, neck and body clamp, sorting pens, spray race or dipping passage, working area, feeding area and loading/offloading zones (Fulwider *et al.*, 2008). Meuling (2006) defines crush pens as channels or passages where cattle move throughout the handling zones, *i.e.* from sorting to the loading platform or even in the opposite direction. It is highlighted by Bowling *et al.* (2008) that the crush pens are usually provided with moveable gates that are used for leading the cattle into the crush. These gates restrict the area behind the animal such that the animal moves forward to where it is required (Aderson and Edney, 1991).

McDermott *et al.* (2010) further highlighted that a funnel-type crush is usually used in handling facilities with a rectangular layout.

A typical funnel shaped crush pen is usually associated with a passageway that directs animals from the off-loading ramp to the scale where their mass is recorded (Collyer and Viljoen, 2003). In the conventional method, the animals are manually driven through the passageway to the weighing scale prior to tagging and identification (Notter *et al.*, 1979). Fulwider *et al.* (2008) caution that this practice is likely to result in difficulties of animal identifications as they would have been weighed without tagging and identification, which is an issue also identified by Grandin (2003).

### **2.2.1 Cattle Weighing System**

It is important to select and locate weighing scales to ensure easy and effective animal handling (ATL, 2010). There are four categories of scales namely: spring balance scales, hydraulic scales, oil bath scales and electronic scales (Grandin, 2003). Cattle arrive at the weighing area where their mass is captured. If an electronic scale is used, the reading is displayed on the dial, and if an analogue scale is used, the animal's mass is indicated by the counter mass it balances (Ford, 2010). In manual systems, the observed reading is manually recorded in the data book by the attending registrar/clerk for later compilation and information storage (Grandin, 2000a). There are limitations associated with the manual capturing of cattle mass data which include the following:

- the risk of losing information recorded during weighing (Galyean *et al.*, 2010),
- the risk of data mix-up as identification and tagging are done after weighing (Grandin, 1990), and
- the risk of recording or capturing incorrect readings from the scale as influenced by the skill and fatigue of the operator (Collyer and Viljoen, 2003).

### **2.2.2 Tagging and Identification**

Tagging of an animal refers to the placement of identifiers on the cattle's ear. The identifier could be a unique plastic tag with a code or a number written on it (Meuling,

2006). Tagging and identification are done when the animal is held in the neck and body clamps which are located in the working area of the handling facility (Taltec, 2010). Figure 2.1 shows a typical working area showing the neck clamp where the animal is restrained during the tagging process. According to Louw *et al.* (2003), there is a risk of having two or more animals with the same identity number or code which could be the result of tagging after data acquisition. After tagging and identification, the animals are then released to the sorting gates for them to be allocated to their respective pens (Grandin, 1984).



Figure 2.1 Typical working area (Breedt, 2003)

### 2.2.3 Cattle Sorting

Sorting refers to the allocation of cattle to a holding pen according to various criteria such as mass and stage of growth (Grandin, 1997). Vink (1987) further explain that the sorting system comprises of gates that lead to different pens from a central passage where the tagging and identification are done. Figure 2.2 contains a typical plan view of a multiple sorting gate leading from a cow identification system.

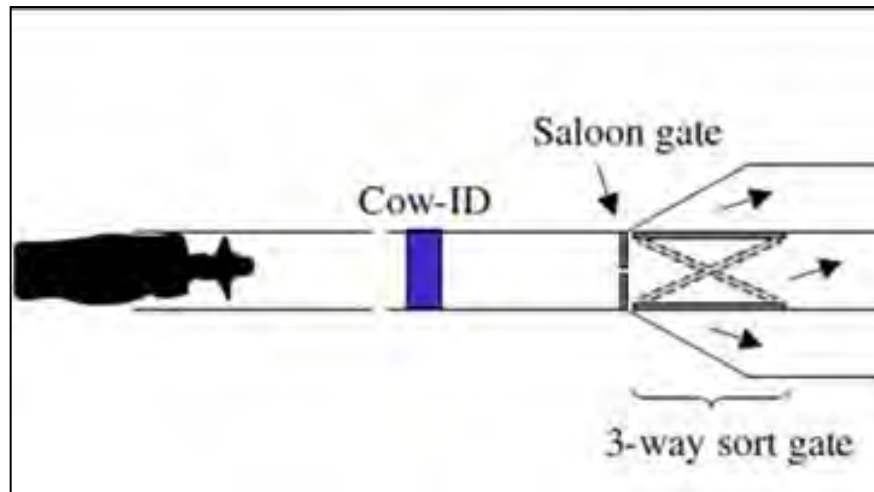

Figure 2.2 Typical sorting gates leading from clamp (Boontech, 2010)

According to Mukuahima (2008), the decision of how the animals are to be sorted is based on the animal mass and the management requirements. From research findings in a 500 cattle facility in South Africa, it takes approximately 3.6 seconds and 55.0 seconds for the identification and weigh-sort procedures to be undertaken respectively with 6% incorrect sorting (Strydom *et al.*, 2008). According to Lambooij and Merks (1989) the average values obtained from experimentation in Dublin for a similar facility size were approximately 3.4 sec and 49.0 seconds for the identification and weigh-sort procedures to be undertaken respectively with 2-3% incorrect sorting. Due to the fact that errors and mistakes are not easily identified, Mapiye *et al.* (2007) noted that processing when using a manual system increases the chance of incorrectly sorting animals as a result of mistakes carried over from the identification and weighing systems. Ratsaka (2009) reports that in South Africa a 500 cattle handling facility costs R500 000 to construct with a monthly operational cost of R 45 000. The conventional system discussed above would require 30 men in order to handle 500 cattle per day with an average of 6% incorrect identification errors. Lambooij and Merks (1989) reported that a 500 cattle handling facility in Dublin cost the equivalent of R65 000 at current (8.0 ZAR: 1.0 USD) currency exchange rates to construct with a monthly operational equivalent cost of R 25 000 and it requires 20 skilled men to handle between 400-600 cattle per day with 2-3% incorrect sorting errors.

#### **2.2.4 Feeding and Dipping System**

Butchbaker *et al.* (1999) reported that a fully grown cow consumes approximately 6-10 kg of dry matter and 40-50 litres of water per day. Conventional feeding uses a community feeding method whereby the animals feed from a common trough without rationing feed quantities and without limiting or monitoring individual consumption (Chipa *et al.* (2010). Mapiye *et al.* (2007) highlighted that with community feeding, data on individual animal feed consumption are not available to improve management practices for the successful operation of the enterprise.

Cattle diseases are transmitted by ticks and SAFA (2010) state that in cases of a serious infection it can cause anaemia. In South Africa the widely used control methods for ticks are: spray race, immersion dipping, and pour-on remedies (Ratsaka, 2009). The major limitation of this conventional manual management practice is that there is a possibility of carrying over of incorrect data from previously incorrect information and less consideration of animal welfare thus, causing injuries and harm to the animal (Maton *et al.*, 1985).

#### **2.2.5 Challenges of Stress and Fatigue in Conventional Handling**

Research has revealed that conventional or manual handling systems are associated with high stress levels that affect meat quality produced from feedlots (Strydom *et al.*, 2008). According to Anderson *et al.* (2005), animal heart rates as high as 108 beats per minutes have been a common feature in some manually operated feedlot systems, due to long waiting periods during handling. This extreme heart rate translates to breathing frequencies in the range of 19 flanks per minute and operator heart rates of 125 beats per minutes have been recorded (Strydom *et al.*, 2008). Cattle breathing frequencies of 18 breathing cycles per minute, heart rates of 105 beats per minute and operator heart rates of 122 beats per minute were recorded at the University of Nebraska, Agricultural feedlot Research and Development Center (Anderson *et al.*, 2005). These aspects have negative impacts on business profitability as they have an adverse effect on meat quality and the ergonomics of the handling system (Apple *et al.*, 1994). In the USA, conventional cattle handling systems are being given less preference due to their poor

ethical rating. These research findings were also confirmed by McDermott *et al.*, (2010), who emphasised the need to establish intervention methods to facilitate the reduction in cattle and handler stress levels.

### 2.3 Electronic RFID Cattle Management Systems

The technology that makes use of electronic identification (RFID) as a control interface for livestock handling is currently available in simple or complex forms (Eigenberg and Brown-Brand., 2005). It works with both an identifier; which is read and an interrogator; the reading device (Artman, 1999). According to Samad *et al.* (2010) transponders and readers are the most common components. They define a transponder as a device that transmits and responds to electronic interrogation by a reader panel. A reader panel is a device that interrogates a transponder by sending an electromagnetic signal, thereby activating it for data transmission (RFID Journal, 2005). Some of the identifiers currently utilised include implantable chips, rumen boluses and ear tags, as illustrated in Figure 2.3 (IDEA, 2003). Implantable chips consist of integrated circuits used for identification that are implanted underneath the animal's skin (Hossain and Quaddus, 2010). Rumen boluses are electronic devices for identification that are placed in a container and administered to the cow through the mouth and reside in the rumen (Llie-Zudor *et al.*, 2010). Electronic ear tags may be made up of plastic or metal tags which house an integrated circuit that has an identification number or code Lewis (2010). These are pinned onto the cattle's ear cartilage for identification (IDEA, 2003).

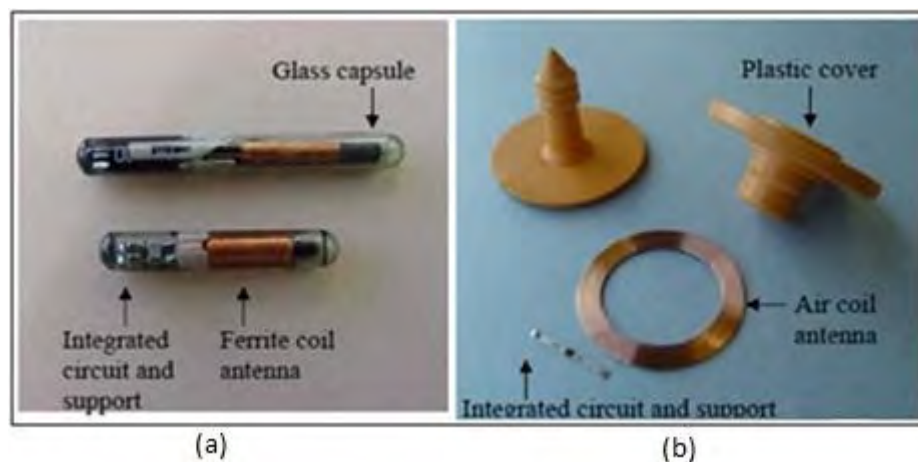

Figure 2.3 Transponders in (a) rumen boluses and (b) ear tags (IDEA, 2003)

According to IDEA (2003), the three main types of readers are hand-held, movable and stationery readers. It is essential that the reader creates a field and, as soon as the identifier enters, the field is activated and the reader then receives the signal that comes from the transponder (Schleppe *et al.*, 2010). Stationary readers, as illustrated in Figure 2.4, are widely used for free range animals and where the animals are unattended (IDEA, 2003). This stationary reading unit is placed in a chute where the animals will pass through for optimum handling (Rudd, 2010).



Figure 2.4 Examples of stationary reader panels (IDEA, 2003)

Aarts *et al.* (1992) states that for optimum working conditions the readers should be placed 750 mm apart. This will enable only one cow to be in the readers' range at a time and avoid collisions caused by having two identifiers in the reader's range at the same time (Bowling *et al.*, 2008). Normally the transponders are best read if travelling at a speed of not more than  $2 \text{ m.s}^{-1}$  (Aarts *et al.*, 1992). It is of importance to also investigate the functional characteristics of these electronic devices in order to evaluate the preferred device to use (Voulodimos *et al.*, 2010).

### 2.3.1 Reading of Electronic Identifiers and Control Interfaces

Pendell *et al.* (2010) recommended that electronic readings be undertaken by a skilled operator to avoid mistakes and errors. The identifier is first tested before it is applied to the animal to ensure that it is not defective (Voulodimos *et al.*, 2010). As a rule of thumb, an identifier that shows signs of damage or fault must not be applied to the animal as it may not be reliable when in use (Aarts *et al.*, 1992).



Stationary or static reading involves the use of hand held readers directed at an animal that is restrained and this method is time consuming and tiresome (Voulodimos *et al.*, 2010). According to IDEA (2003) this method requires the reader to be passed exactly over the identifier's positioning, thus hand held readers are mainly utilised for small herds. Hanton *et al.* (1992) states that in dynamic reading the animals pass through a single file raceway where the panel readers will be on the sides of the corridor. As the transponder comes into the field of the reader it is activated and identified (Aarts *et al.*, 1992).

### **2.3.2 Applicability and Performance of Electronic Management**

According to Lambooij and Merks (1989), the technology of electronic identification can be utilised for good farm practices. Results from a study conducted in Dublin, indicate that implantable electronic transponders, also referred to as IETs, offer a more reliable system for individual animal identification compared to visual tags alone (Lambooij and Merks, 1989). From approximately 150 experiments conducted in Ireland under different conditions and climates, a 97.5% success and recovery rate (obtaining them back after use) of the electronic identification technology was achieved (Lambooij and Merks, 1989).

Before 1989 there was little consensus on the best implantation site for the various IETs (Aarts *et al.*, 1992). Studies were then undertaken by Aarts *et al.* (1989) on four sites of a cattle's body and it was found that the most suitable position on which the RFID tag was to be applied is under the scutiform cartilage of the ear. This was first recommended by Fallon *et al.* (1991) and confirmed as suitable by Hasker *et al.* (1992).

Hanton *et al.* (1992) highlighted that a drawback of the utilisation of injectable transponders was that there is risk of not recovering the device after slaughter and thus IETs are usually regarded as an unacceptable method of identification for animals to be slaughtered. Other experiments conducted showed the possibility of utilising a rumen bolus as a means of identification (Eigenberg *et al.*, 2005); where sifting through the stomach contents at slaughter house was conducted to recover the device.

However, according to Lambooij and Merks (1989), careful consideration is required when selecting the type of identifier to use between the rumen bolus and ear tag as they both have similar advantages. When comparing the rumen bolus and the ear tags they found that reading a bolus was more difficult when used with hand held readers. This was also confirmed by Holmes (1991) in his literature review on practical animal handling.

### 2.3.3 Comparison between Electronics Tags and Rumen Boluses

An experiment to compare the use of electronic tags and rumen boluses as a means of identification was conducted at the Teagasc, Grange Research Centre (Erasmus *et al.*, 1999). In this experiment 1120 cattle were used in the study. The categories varied from beef cows, 1-5 weeks old calves, weaners, replacement heifers and feedlot cattle that were due for slaughter within 100 days (Erasmus *et al.*, 1999). The experiment made use of rumen boluses and tags supplied from key manufactures, namely Allflex and Nedap (Allflex, 2010). The study commenced in September 2000 and the results after 7 months of observation are summarized in Table 2.1. The results indicate that boluses are more durable and reliable compared to electronic ear tags.

Table 2.1 Rumen bolus and electronic tags comparison (Erasmus *et al.*, 1999)

<b>PERIOD</b> (When readings were taken)	<b>ALFLEX</b> (Units still active)		<b>NEDAP</b> (Units still active)	
	Bolus	Ear tag	Bolus	Ear tag
Day 0	510	511	511	510
Day 7	510	511	511	499
Day 28	510	506	511	489
After 7 Months	505	503	506	487
Not reading at 7 Months	5	8	5	23
% Change	0.98	1.57	0.98	4.51

Eradus *et al.* (1999) conducted a holistic analysis that included economics, applicability and effect on animal welfare of the boluses and tags. They concluded that, although boluses seem to be more durable, analysing all other factors like cost, reading distance and applicability, the result favoured the use of electronic ear tags as they are easily available, cheaper and easy to administer.

Walker (2009) reported that electronic ear tags in cattle make use of radio waves operating at a low frequency. The waves are able to pass through living tissue. The ISO 11784 standard is the set of guidelines that explains the identification code structure itself (ISO, 2010a). The ISO 11785 standard focuses on the technicalities of the tag and reader to ensure compatibility (ISO, 2010b). In these standards it is specified that the 134.2 kHz band is the operating frequency for animal identification. Information interchange between tag and reader is based normally on either a half-duplex (one way communication at a time) or a full duplex (both ways communication at the same time) protocol, defined and symbolised by (HDX) and (FDX-B) respectively. After the transponder sends a signal to uniquely identify itself, it reverts back to its passive state waiting to be activated again by a reader field (ISO, 2010b). Walker (2009) and Hardy and Meadowcroft (1990) further noted that the limitations in the conventional manual feedlot management practices have been outlined by many scholars and the need of an automated system has been highlighted. The next section uses case studies where the suggested RFID technology has been applied and the performance evaluated.

## **2.4 Case Studies of RFID Technology Implementation for Cattle Handling**

In this section case studies from other countries where RFID, automation and electronics have been introduced for animal handling and identification systems to improve management practices are discussed and summarised.

### **2.4.1 Application of RFID Tags for Cattle Management**

Naas (2002) reported that the use of RFID ear tags yield a number of advantages in the management of cattle feedlots. In addition, electronic tags can be regarded as a

significant improvement compared to the visual reading of codes and numbers. The 52% reduction in labour cost, 12% in reduced cattle stress levels and 18% reduction in operator fatigue are highlighted as one of the major advantages of the use of RFID tags (Naas, 2002). Artman (1999) concluded that the use of RFID tags reduced incorrect readings from 6% to 0.1%.

Naas (2002) reported that for a 500 cattle handling system averages of 0.66 seconds and 10.25 seconds were measured as the identification and weigh-sort durations respectively for the RFID based system with 0.1% incorrect sorting. This infrastructure was designed to be operated by 13 men at an equivalent operational cost of R 12 000 per month based on 8.0 ZAR: 1.0 USD exchange rate. Bowling *et al.* (2008) confirmed Naas's (2002) results as they measured a reduction of cattle stress levels after the adoption of an automated RFID system. Using this system, an operational lower heart rate of 85 and 102 for cattle and operator respectively were observed (Bowling *et al.*, 2008). Lower cattle breathing frequency of 13 cycles per minute was also observed in these studies, indicating reduced stress levels.

Geers (1997) postulated that the use of electronic tags in animal production and management practices opens possibilities for the monitoring of tasks such as automatic sorting, feeding and health treatments. This was confirmed by tests and experiments conducted by Artman (1999) where specific technology was developed and tested successfully for improved management practices.

#### **2.4.2 Animal Identification, Weighing and Auto-sorting Applications**

The first case study reviewed, details the application of electronic ear tags equipped with TROVAN ID-100A tags (TROVAN, 2009) and visual tags for the management of a 35 000 head of cattle at Campo Ranch in Argentina. A computer and management software were utilised in the study. It was found that the electronic identification of animals was 60% faster with less stress on the animals and time saving in the operations (TROVAN, 2009).

The second case study reviewed on the application of RFID was conducted on a dairy farm in Dublin, Ireland (Dairymasters, 2009). RFID technology operating at 125 kHz with passive tags and a short read range of 800 mm was used. The objective of the study was to identify cattle using RFID technology and use the information in cattle management practices for a dairy herd. The RFID technology was utilised in the identification of cattle when weighing, milking, feeding, dipping and sorting. The system also incorporated management software that recorded data and performed feeding schedules based on the user instructions. The feed was also quantified and rationed for each animal according to the milk yields. There was a reduction in labour costs as the labour requirements were reduced from 13 to 6 personnel where one operator could manage the milking of 800 cows in a period of 3.5 hours.

In a study in Route d'Arles, France, the Institute of Natural Resources Arles, in collaboration with the WALLACE foundation, developed and tested an automatic sorting system for sheep using RFID (INRA, 2009). The technology which made use of electronic tags in sheep sorting resulted in time and manpower savings. As indicated in their evaluation, the system was able to sort an average of 700 ewes in 20 minutes which is 80% faster than manual sorting, resulting in a reduction of an equivalent of almost 200 labour hours per week whilst achieving a 55% overall reduction in handling duration.

Figure 2.5 shows a plan view of a sorting system that was developed by people at INRA (2009) and which makes use of RFID technology. As indicated in the INRA (2009) report, the sheep pass through the RFID detector and an RFID compatible electronic scale system after which, via the management software, the sheep are sorted to either camp A or B based on the sheep's mass. Should the device fail to read, the animal is directed to a device error channel where it is marked by ink for further attention.

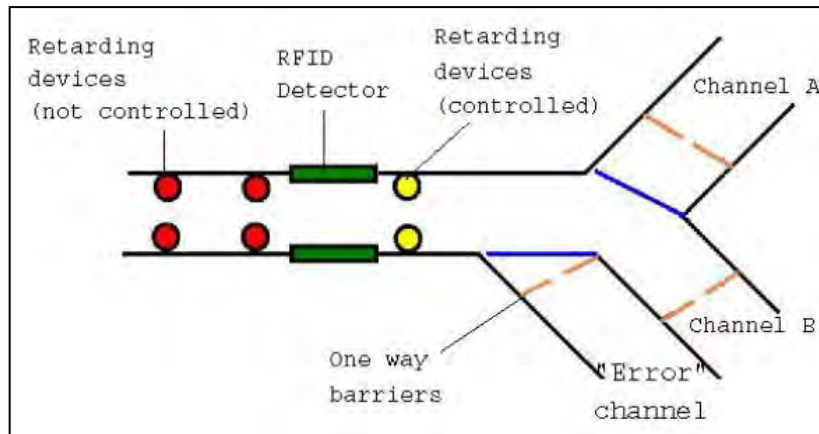

Figure 2.5 Sorting unit making use of RFID technology (INRA, 2009)

Boote and Mavundza (2009) developed a four way automated sheep sorter at a cost of less than R 50 0000 and which is capable of sorting an average of 720 sheep per hour. They also reported that the sheep sorter was designed and constructed to be portable to the extent that it only required two men to be able to lift it into the back of a truck for transport. Mavundza (2010) highlighted that the sorting module was part of the electronic management of livestock using RFID technology project being undertaken by the Agricultural Research Council-Institute for Agricultural Engineering (ARC-IAE) in South Africa and the idea would be adopted for cattle systems.

### 2.4.3 Case Study of a Total Management System

Another case study, conducted at Corona Range and Livestock Research Centre, was reviewed to investigate the benefits of using RFID ear tags to complement individual animal record-keeping (Cox *et al.*, 2006). In the investigation visual and electronic ear tags, a reader system, a compatible electronic scale, indicators, various management software suites for example Beeflink, Cow sense, CattleMax2, GMP Basic, RFID compatibility, an image capturing device and a computer system were used. In their study they established a system which included capabilities such as records of individual animal performance, automated electronic mass recording, monitoring performance during weighing, and information interchange with herd management software without any information loss.

It was also established that a comprehensive recording system working on 500 head of cattle would cost an equivalent of R40 000.00, excluding the feeding and dipping mechanism (Schleppe *et al.*, 2010). In the 3 year duration of the project, 150 electronic tags fitted to cattle were 100% responsive and only one tag was lost, whilst the replacement rate for the visual tags was in the range of 2.7% (Cox *et al.*, 2006). Dean *et al.* (1992) stated that electronic ear tags are the most widely used identifiers and they consist of two basic components, namely the internal integrated circuit and the outside shell holder which is fastened onto the animal's ear. An animal is fitted with two tags, an electronic tag attached to the left ear and a visual tag on the right ear. Cox *et al.* (2006) argued that the use of RFID technology/tags also come with a price to pay in maintaining the technology as there is need for regular servicing of all the equipment, software upgrades, computer maintenance and upgrades to keep up with technology. The use of the technology reduced animal handling duration by 60%, labour force by almost 50%, data recording errors by almost 5% and also reduced animal and handlers stress by 10% and 15% respectively through reductions in handling and sorting times, whilst at the same time remained responsive even after 3 years of use (Cox *et al.*, 2006). It was also reported that this management practice reduced sorting time by 3-4 hours per day for 500 cattle, which in turn reduced animal stress and worker fatigue, thus increasing the operational profit margins.

## **2.5 Summary of System Performance**

The main objective of establishing a feedlot operation is to maximise the rate of mass increase through specialised feeding and handling. In order to have an understanding of how the systems can be improved, it is necessary to review the handling facility layout and key livestock management zones. The sections below contain summarised information from studies reported in the literature of what a conventional handling system entails, the limitations of manual handling, and success factors from other countries where automated RFID systems have been incorporated. A summary of reported problem areas in the conventional systems used in South African and potential solutions are presented.

### **2.5.1 Characteristics of a Standard Design Handling System**

For the purpose of this study reference is given to a standard design of a 500 cattle handling system. The system described consists of the basic areas:

- receiving area (offloading and loading ramps and circular forcing gate),
- holding pens (10 pens of 50 cattle each at 2 m<sup>2</sup> per animal) and,
- handling area (box shaped crush, scale area, control gates, restraining and sorter).

Of importance to this study is the handling area where the flow control, identification, weighing, restraining and sorting is undertaken.

### **2.5.2 Comparison of Manual and RFID Systems**

A number of limitations have been reported in conventional or manual handling systems, both locally and abroad, with regards to animal restraining, movement, identification, weighing, animal stress and sorting (Grandin, 1994). In the studies reviewed the adoption of automated RFID techniques have resulted into enhanced system performance.

Table 2.2 contains a summary of performance parameters of both conventional manual and automated RFID based handling systems, from both South Africa and other countries.

In addition to the economic and physical parameters considered when evaluating the impact of system improvements, there is also need to undertake an ergonomic evaluation. For ergonomic evaluation, the average handling durations of each procedure is obtained and utilised to compute the savings in man hours, operational costs, system efficiencies and Cardiac Cost of Work (*CCW*) and Cardiac Cost of Recovery (*CCR*) using the heart rate monitoring results. Total cardiac cost is a measurement of the area under the curve obtained by plotting the heart rate for each minute during work and recovery. (Jandrow *et al.* 1982).



Table 2.2 Performance limitations of the two handling systems (Grandin, 1994)

Aspect of Consideration	Manual Livestock Management		Automated RFID Incorporated Systems	Impact of Introducing RFID Based Technology Into Livestock System
	South Africa	Other Countries		
Consideration Handling Facility size (capacity: Animals per day)	500	500	500	Baseline for comparison
Cattle Identification (ID duration per animal) in seconds	3.66	3.40	0.66	Decreases handling duration, man hours, stress, fatigue and costs
Weighing and Sorting (duration per animal) in seconds	55.00	49.00	10.25	Decreases handling duration, man hours, stress, fatigue and costs
Incorrect Sorting%	6%	2-3%	0.1%	Decreases incorrect management decision
Operational Cost R	R 45 000	R 30 000	R 15 000	Increased profits margins per year
Labour Requirement (Handlers)	30	20	10	Decreases operational costs, low profit margins
Cattle Breathing frequency (Breath cycles per minute)	19	18	13	Lower stress levels results in better meat quality
Cattle Heart-rate (Flanks per minute)	108	105	85	Reduced stress levels results in better meat quality
Operator Heart-rate(Beats per minute)	125	122	102	Manual handling not ergonomically friendly

The results in Table 2.2 indicate that incorporating an automated RFID technology in a handling system increases both efficiency and operational costs. South African feedlot systems have been shown to be performing poorly with regards to system efficiency. In this regard, there is a great need to identify key areas where automation and RFID technology can be incorporated to increase system efficiency. Table 2.3 summarises information from the literature that demonstrates how incorporating automated RFID technology has improved system performance in other countries.

The results in Table 2.3 indicate that incorporating an automated RFID technology in a

handling system increases both efficiency and business profitability. South African feedlot systems have been shown to be performing poorly with regards to system efficiency, ergonomics and business profitability (Ratsaka, 2009). In this regard, there is a great need to identify key areas where automation and RFID technology can be incorporated to increase business profitability and system efficiency.

Table 2.3 Benefits of incorporating RFID technology in animal handling systems

Item	Aspect	Benefits Realised by Automated RFID Technology Introduction
1	Handling Duration	Beef cattle handling duration was reduced by 60% at Corona Range and Livestock centre (Cox <i>et al</i> , 2006)
		Sheep handling duration and sorting were reduced by 55% and 80% at Route d'Arles Natural Resources Institute (INRA, 2009)
		Reduced sorting time by 3-4hrs per day for 500 cattle at Corona Range and Livestock Centre (Cox <i>et al</i> , 2006)
		60% faster identification for 3500 cattle at Compo Range in Argentina (TROVAN, 2009)
2	Handling Errors	Animal incorrect sorting was reduced from 6% to 0.1% at Teagasc Research Institute (Artman, 1999)
		Sheep sorting was 80% faster at Route d'Arles (INRA, 2009)
		Data handling errors reduced by 5% at Corona Range and Livestock Centre (Cox <i>et al</i> , 2006)
3	Labour Requirements	Labour requirement reduced from 13 to 6 for dairy system handling in Ireland (Dairymaster, 2009)
		Labour reduced by almost 50% at Corona Range and Livestock Centre (Cox <i>et al</i> , 2006)
		Labour saving of 200 man hours per week for sheep handling at Route d'Arles (INRA, 2009)
		52% reduction in labour cost was realised in various automated RFID systems (Naas, 2002)
4	Animal Stress Levels	Stress levels reduced by 10% at Corona Range (Cox <i>et al</i> , 2006) 12% reduction in stress levels at Teagasc (Naas, 2002)
5	Handler Fatigue Levels	Cattle handler fatigue levels were reduced by 15% at Corona Range and Livestock Centre (Cox <i>et al</i> , 2006) Cattle handler fatigue levels were reduced by 18% at Teagasc (Naas, 2002)

An economic analysis is, however, required to be able to test the hypothesis of improved business profitability with the introduction of RFID based cattle handling technology.

### 2.5.3 Cost Benefit Analysis

One of the key items in any business case is an analysis of the costs of a project that includes some consideration of both the cost and the payback period, either in monetary or other terms (Levitan, 2010). For small projects that run for less than a 5 year duration with budgets not exceeding R20 000 000, a cost-benefit analysis can be simple and Table 2.4 contains an example of what benefit could be derived and what evidence may be required.

Table 2.4 Cost benefit analysis focus areas (Levitan, 2010)

<b>Benefit of Proposed Product</b>	<b>Evidence</b>
Return on investments	Financial analysis of the cash flows associated with the new RFID technology, to show a net gain. Simple payback techniques are considered adequate for small projects that run for less than a 5 year duration with budgets not exceeding R20 000 000.
Improved performance, e.g. lower operating costs, improved meat quantity and quality, improved system ergonomics, higher speed or more flexibility	Technical capabilities of the proposed RFID based system showing: <ul style="list-style-type: none"> <li>• expected gains in productivity gains,</li> <li>• reduced inefficiency, e.g. incorrect sorting, and</li> <li>• reduced stress levels.</li> </ul> Such information might come from: <ul style="list-style-type: none"> <li>• suppliers,</li> <li>• the results of pilot studies,</li> <li>• the experience from other studies,</li> <li>• the results of a customer survey showing that the aspect of customer service in question is a priority for customers, and</li> <li>• analysis of the technical capabilities of the technology in relation to customer requirements, showing that the stated aspects of customer service are likely to be improved.</li> </ul>
Improved service	Information that other competitors are already investing in equivalent technology, and therefore not to do so would be to fail to keep up. Feedlot owner's surveys that demonstrate that the quality/service improvement predicted will attract/keep customers more effectively than at present.

Table 2.5 contains a selection of cost benefit analysis methods that are most commonly utilised as a way of demonstrating system advantages that translate to financial gains through technological improvements (Levitan, 2010).

Table 2.5 Selected cost benefit analysis methods (Levitan, 2010)

Aspect	Detailed Description of the Aspect
Payback	<p>The amount of time required for the cash inflows from a capital investment project to equal the cash outflows.</p> <p>Payback period = Initial payment/Annual cash inflow</p> <p><i>The shorter the payback period, the better the investment, under the payback method.</i> Projects with large costs should employ a more sophisticated analysis based on net present value (NPV) or internal rate of return (IRR), as explained below.</p>
Average Rate of Return (ARR)	<p>The average rate of return expresses the profits arising from a project as a percentage of the initial capital cost. However, the definition of profits and capital cost vary. For instance, the profits may be taken to include depreciation, or they may not. One of the most common approaches is as follows:</p> <p>ARR = (Average annual revenue / Initial capital costs) x 100</p> <p>Although this method is considered simple and easy to use, the method does not take account of the project duration or the timing of cash flows over the course of the project. Thus it is difficult to decide whether or not to invest. This lack of a guide for decision making means that investment decisions remain subjective.</p>
Net Present Value (NPV)	<p>This is a Discounted Cash Flow (DCF) technique. It relies on the concept of opportunity cost to place a value on cash inflows arising from capital investment. NPV is a technique where cash inflows expected in future years are discounted back to their present value. This is calculated by using a discount rate equivalent to the interest that would have been received on the sums, had the inflows been saved. A positive NPV means that the project is feasible because the cost of tying up capital is compensated for by the resulting cash inflows.</p>
Internal Rate of Return (IRR)	<p>The IRR is the annual percentage return achieved by a project, at which the sum of the discounted cash inflows over the life of the project is equal to the sum of the capital invested. However, IRR should not be used to compare mutually exclusive projects. For example, a project with a lower IRR may in fact have a higher NPV so the potential income (or saving) could be higher and also to compare project of different durations because it doesn't consider cost of capital</p>
Modified Internal Rate of Return (MIRR)	<p>This is usually used to rank various choices. As the name implies, MIRR is a modification of the IRR. MIRR adds up the negative cash flows after discounting them to time zero, adds up the positive cash flows after factoring in the proceeds of reinvestment at the final time period, then works out what rate of return would equate the discounted negative cash flows at time zero to the future value of the positive cash flows at the final time period. This rate of return is the MIRR.</p>

Given the relatively small scale of projects addressed in this study, the payback period method was used as suggested by Levitan (2010) to analyse and compare the benefits of an automated RFID based system to a manually based system. The motivation for the use of the pay back method (Levitan, 2010) includes the following:

- It is simple. Research has shown that UK companies favour it. This is understandable given how easy it is to calculate
- In an environment of rapid technological change, systems may need to be replaced sooner than in the past, so a quick payback on investment is essential.

There is also a need to obtain statistical evidence to support the benefits realised.

#### **2.5.4 Statistical Methods Used to Substantiate Benefits**

In-order to obtain an informed choice it is important to employ analytical methods to analyse the performance of the two systems in order to establish the benefits supported by statistical evidence (Naas, 2002).

Assuming that the data are normally distributed, a Student's *t*-test can be used to test and compare the mean performance parameters of the manual and automated systems (Cox *et al*, 2006). According to Anderson *et al.* (2005), the comparison would analyse the difference between the two mean values in relation to the variation in the data obtained from both systems. In this case, a null hypothesis was constructed to assume that the introduction of automated RFID technology will not result in any system improvement. The results from the student's *t*-test can be used to test the null hypothesis. A significant result at the 95% probability level implies that the data supports the conclusion with 95% confidence, although there is a 1 in 20 chance of being wrong (Anderson *et al.*, 2005).

#### **2.5.5 Need Statement for South African Feedlots Systems**

Standard designs have been prepared by the Department of Agriculture and other feedlot operators in South Africa since 2007 and there are approximately 13 units in operation to date (NDA, 2010). The systems consist of a weighing station, handling area, cattle flow control sliding gates and a three way manually operated sorting systems, as illustrated in Figure 2.6. The handler and sorting gates are constructed primarily of 75 mm diameter hollow section high tensile steel. Both gates can swing 1000 mm during sorting to create an 800 to 1000 mm passageway. All other passageways, with the exception of the box shaped circular crush assembly, are

generally made of 125-150 mm diameter treated poles and four 75-100 mm stranding poles established in approximately 400 mm x 400 mm concrete footings which are 600 mm deep (Mutenje, 2010a). The lead up race gates and sliding gates at race entry are manually operated and positioned, as shown in Figure 2.6.

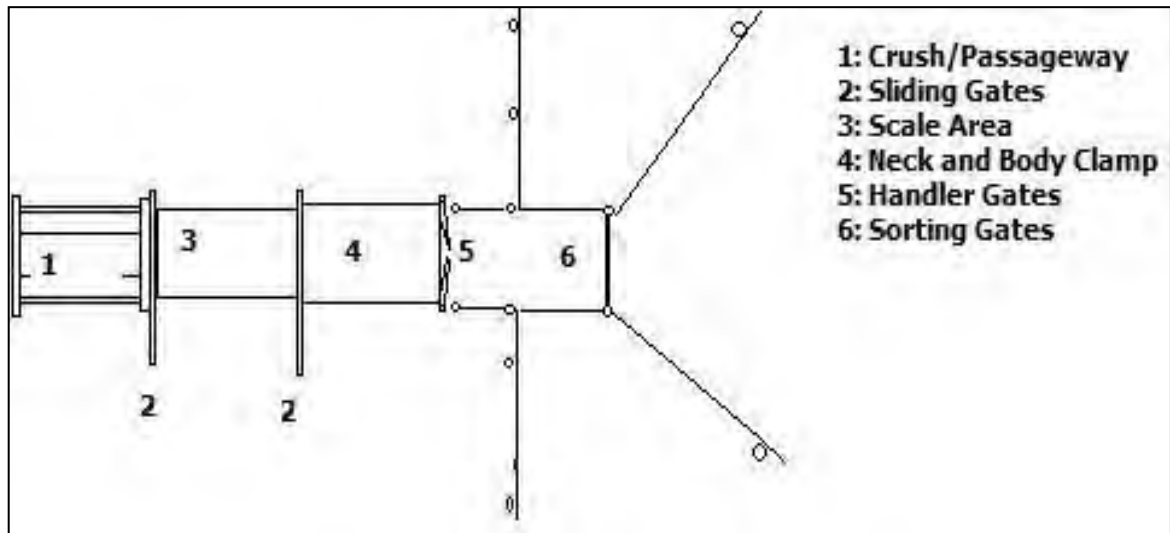

Figure 2.6 Standard conventional cattle handling system layout (Mutenje, 2010b)

## 2.6 Design Problem Areas

According to Ratsaka (2009), surveys conducted by the ARC-IAE revealed a number of limitations experienced by operators that make use of the standard conventional system and these are summarised in Table 2.6.

From the survey conducted by the ARC-IAE, it is however important to research and develop solutions to the identified challenges and limitations (Mutenje, 2009). The following chapter contains the concept design and methodologies followed throughout the problem solving process.

Table 2.6 Design problem areas of the cattle handling system (Naas, 2002)

<b>DESIGN AREA</b>	<b>DESIGN PROBLEM</b>
Box shaped crush and flow control system	<ul style="list-style-type: none"> <li>• Noisy gate operations</li> <li>• No adequate anti- backing system</li> <li>• Structurally unsound system</li> <li>• Uncontrollable cattle flow towards the identification and weighing system</li> <li>• Stressful operations (opening and closing of gates manually)</li> <li>• Injuries to animal when gate closes late</li> <li>• Flow speed regulation and individual animal control problems</li> </ul>
Identification and weighing system	<ul style="list-style-type: none"> <li>• Long identification duration</li> <li>• Long handling duration</li> <li>• Inaccurate cattle mass reading</li> <li>• Inaccurate cattle identification</li> <li>• High operator fatigue levels and</li> <li>• High animal stress levels</li> </ul>
Sorting System	<ul style="list-style-type: none"> <li>• High incorrect sorting levels</li> <li>• Noisy gate operations</li> <li>• Long sorting duration</li> <li>• Strenuous sorting gates operation</li> <li>• Difficult selective sorting</li> <li>• High operator fatigue in operations</li> <li>• High cattle stress levels</li> </ul>
Complete system	<ul style="list-style-type: none"> <li>• High handling duration</li> <li>• High stress levels to animal</li> <li>• High handler fatigue levels</li> <li>• Long sorting duration</li> <li>• High operational costs</li> <li>• High incorrect cattle sorting</li> <li>• High labour and man hours requirements</li> </ul>

### **3. CONCEPTUAL DESIGN AND METHODOLOGY**

In order to develop an improved cattle handling system, the following design requirements were considered:

- the funder's requirements (ARC-IAE),
- standardisation, and
- technical requirements.

The major criteria to be achieved include reduced handling duration, reduced stress on animals and operators, reduced incorrect sorting and enabling automated selective sorting. Standardisation and technical requirements, for functionality of the intended system were considered in the development of the engineering design.

#### **3.1 Funder's System Requirements**

It was highlighted by the ARC-IAE that they would prefer Precision Livestock Farming (PLF) techniques and automation systems to be incorporated into a standard cattle handling facility design. With the global increase in PLF and use of automated RFID technology, the design was divided into the following three main areas:

- a cattle flow control system,
- a cattle identification and weighing system and,
- a cattle sorting system.

Table 3.1 contains the concept and specification requirements for the movement control, identification, weighing and sorting systems. Specific requirements and intended achievements for each section are also contained in Table 3.1.



Table 3.1 Concept and specification principles of the proposed system

DESIGN AREA DESCRIPTION	CONCEPT AND SPECIFICATION PRINCIPLES
Cattle flow control system	<ul style="list-style-type: none"> <li>• Regulates cattle flow speed</li> <li>• Allows only one animal at a time into the identification system</li> <li>• Includes an anti-backing system</li> </ul>
Cattle identification system	<ul style="list-style-type: none"> <li>• Identifies cattle (tags and readers)</li> <li>• Captures and uploads cattle identification and mass</li> </ul>
Cattle sorting system	<ul style="list-style-type: none"> <li>• Receives sorting decision from control and identification system</li> <li>• Selective sorting of cattle on a mass basis into 3 categories, i.e. ready for market, still requiring feeding but ready for next dispatch and those still requiring constant attention for mass gains</li> </ul>

### 3.2 Selection Considerations

When designing a sorting system, the factors to consider are the cattle forward velocity, environment and animal learning and adaptation. This section contains details and impacts of the above factors in the crush and handling area, the environment in the sorting facility together with learning and adaptation by the cattle.

#### 3.2.1 Forward Velocity

According to Taylor (1997) beef cattle have a low speed of forward movement. On average an adult beef animal being handled walks at a velocity of between  $1.4 \text{ m}\cdot\text{s}^{-1}$  (Ewbank and Parker, 2007) and  $0.65 \text{ m}\cdot\text{s}^{-1}$  due to anxiety of being handled (Grandin, 1998), although heifers generally walk faster than adult cattle (Grandin, 2000a). The floor characteristics also have the effect of slowing or increasing walking speed (Stefanowska *et al.*, 1998). The effect of forward speed effect in the design is primarily for the determination of distance between sensors and gates in the flow control system (Nilsson, 1992).

### **3.2.2 Lighting in Sorting Facilities**

In gathering areas, light affects the movement of cattle and hence they tend to concentrate where there is more light intensity (Vowles and Hollier, 1982a). However in motion, cattle are usually afraid of the dark and thus walk faster in darker than in lighter environments. Therefore, the handling facility should have a 32-119 lux lighting environment (Fallon *et al.*, 1991).

### **3.2.3 Learning and Adaptation in Cattle**

Grandin (1980a) observed that cattle usually adopt a “follow the leader” behaviour, thus it is necessary to have some of the gates of a see through type (Murphy *et al.*, 2008). Grandin (1980b) found that equipment with lower noise levels result in a more efficient animal handling environment. A Luminance of 32-119 lux is recommended for the handling system to encourage a constant animal speed (McNitt, 1983). According to CIGR (1984), cattle normally require between 1 to 5 days to adapt to a new operating system.

## **3.3 Concept Design and Methodology Summary**

Above all, the key aspect to consider in the conceptual design process are the specifications set by the funder, standardisation, and system technical requirements. These aspects are to be used as a guide throughout the design process. Forward speed, lighting in sorting facilities and learning and adaptation in cattle would also be taken into account when selecting appropriate technology.

The following chapter contains a discussion of the design process followed by the development of the automated cattle handling system from the entry alley passageway to the exit from the sorting system.

## 4. DESIGN OF AN AUTOMATED CATTLE HANDLING SYSTEM

The following sections summarises the design processes followed during the system development.

### 4.1 Standard Design Procedures

Figure 4.1 illustrates standard agricultural infrastructure design procedures developed and utilised in this study which was adopted from the South Africa Bureau of Standard guidelines (SABS Standards, 2010d). Some virtual reality packages were utilised in the engineering design procedures, including drafting and simulations as illustrated in Appendix A and Appendix B. In the design procedure illustrated in Figure 4.1, these virtual tools were mainly utilised in concept creation, sketch production and modelling of the end product prior to fabrication.



Figure 4.1 Basic standard design procedure (SABS Standards, 2010d)

The following section contains the system prototype development process, which is a further elaboration of the standard design procedure illustrated above.

### 4.2 System Prototype Development

During the design process various virtual prototyping tools were utilised, including CAD software and simulation software in order to evaluate the design prior to construction. In developing the prototype, it was important to consult the end users and clients throughout the research and development process. These consultations identified design problems associated with the current manually based design system. The design process was strengthened by concept sketches, specifications and detailed technical

drawings as illustrated in Appendix A and Appendix B.

The following sections contain a summary of the design and development process for the individual components of the RFID based cattle handling system. As shown in Figure 4.2, the system includes a box shaped crush portion with an operator side catwalk, flow control system, identification/weigh box, sliding gates, restraining system, handler access gates and automated sorting system. The detailed design drawings of the different components are illustrated in the Appendix A and Appendix B containing the design notes and drawings respectively.

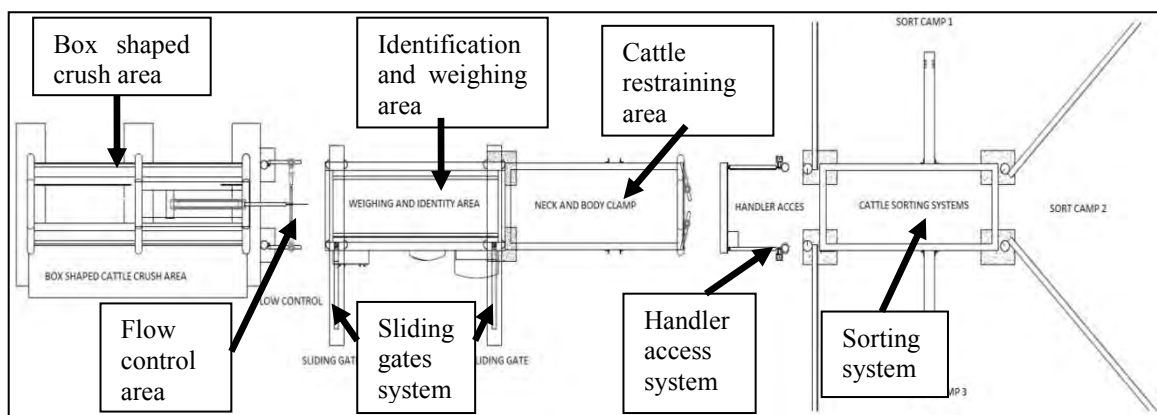

Figure 4.2 Schematic diagram of the RFID based cattle handling system

### 4.3 Box Shaped Cattle Crush Design

A box shaped cattle crush, also referred to as a cattle alleyway, serves the purpose of guiding the cattle in a single file, in their transition from the receiving area to the flow control and handling sections.

The following sections summarises problems with the existing manually operated systems and proposed solutions.

### 4.3.1 Design Problems in Existing Box Shaped Cattle Crush Systems

Table 4.1 contains some of the design problems highlighted by end users of the manual based system.

Table 4.1 Problems in the existing box shaped crush systems

ITEM NO.	DESIGN FACTOR	DESIGN PROBLEM
1	Unpredictable cattle behaviour in the crush	<ul style="list-style-type: none"> <li>• May be caused by contrasting light levels in the crush design finish and colours</li> </ul>
2	Cattle flow problems caused by wall design	<ul style="list-style-type: none"> <li>• Uprights distracting flow</li> <li>• Overlapping sheets causing harm to livestock</li> <li>• Screw and sharp objects protrusions</li> </ul>
3	Cattle slip along passage	<ul style="list-style-type: none"> <li>• Smooth floor</li> <li>• Cattle lying down in passage</li> <li>• Passage too wide</li> </ul>
4	Slope along crush affecting flow	<ul style="list-style-type: none"> <li>• Poor drainage and dung removal systems</li> </ul>
5	Bruises and leg injuries	<ul style="list-style-type: none"> <li>• Sharp angled corners causing injuries</li> <li>• Gap between floor and wall too big/small</li> </ul>
6	Race dimension affecting flow	<ul style="list-style-type: none"> <li>• Passage allowing cattle to turn</li> <li>• Areas of passage too narrow for cattle flow</li> </ul>

### 4.3.2 Final Specifications and Detailed Design

Based on literature reviewed and information contained in Smith *et al.* (2009), design considerations used to select the best solutions to overcome the design problems listed in Table 4.1, are detailed below.

To enhance the flow of cattle, a uniform environment in a cattle handling system must be provided. High contrasts in cattle handling operations increases the anxiety levels in cattle by more than 20% and must therefore be limited (Grandin, 1989).

The South African Bureau of Standards developed a series of standards that guide the application and levels of galvanising for cattle infrastructure in SABS 763 (SABS, 2010a) and SANS 121 (SABS, 2010b) which was derived from the ISO 1461 standard

(ISO, 1999a; ISO, 1999b). The coating quality of hot dip galvanising for animal products that would be exposed to climatic condition in South Africa are specified in the SABS Standards (2010e) and SABS Standards (2010f) as category A1-A2, which specify a depth of coating in the range of 55-25  $\mu\text{m}$ .

Appendix A contains the final specification derived from the literature on the design specifications in cattle handling infrastructure design.

It is important that the uprights of the crush walls are constructed on the outside and wall panels on the cattle flow side as experience has shown that having uprights on the cattle side increased the chances of injuries and resistance to cattle flow (Vowles, 1982). The idea proposed by Schoonover *et al.* (2001), cited by SACO (2010), requires that overlapping sheets should be in the direction of cattle flow to reduce the possibility of injuries to the animal, was adopted in this study.

In order to avoid sharp edges at the top and bottom of the internal wall panel it is necessary to have the sheets curved over at the top and bottom to prevent injuries. In addition, all screws and fasteners should be countersunk to avoid bruises and injuries and cattle panel walls should be constructed to a height of 1.5 m for uniformity (NMR, 2010).

Although there are different schools of thought in terms of the characteristics of the panel wall (Vowles and Hollier, 1982b), it is advisable to make use of solid panels for crush walls to minimise outside visual disturbances and reduce the risk of cattle jumping out of the crush.

The recommended specification derived from the synthesis of the above design details and also supported by Vowles *et al.* (1984b) are contained in Appendix A and in Figure 10.1 in Appendix B.

Floor surface specification is also another area of contention in terms of cattle facilities as different scholars have different views of how the floor surface has to be constructed

(Vowles *et al.*, 1984a). The slopes of floors for cattle are generally constructed with a longitudinal slope of approximately 4% for drainage reasons (Vowles *et al.*, 1984b). In some cases the longitudinal slope is dependent on the location of the infrastructure and whether the structure is under a closed roof, where drainage is not an issue, or external and exposed to the elements (Maton *et al.*, 1985). In this study, the infrastructure is intended for external use and drainage needs to be taken into account. For areas that receive moderate rainfalls of about 600 – 800 mm per annum, it is recommended that the floor be constructed of 25 mm deep grooves arranged in 200 mm diamond and square pattern to avoid slip (Vowles, 1982). Appendix A contains design notes and the final specification of the floor surface design.

Many designs avoid sharp angled corners to reduce injuries and use corners with smooth round posts or poles that aid flow is recommended (Marshall, 1977). There is also a need to have a gap of between 80 - 100 mm between floor and wall bottom for drainage and dung removal. These specifications are stipulated in the Government Gazette (2010) as a recommendation to minimise injuries as specified in the design notes.

Referring to Appendix A which contains the design computations, assuming a crush width of 430 mm at the bottom and 900 mm at top of the wall, a 500 kg average animal mass with a length of between 1.5 - 2.5 m would apply a force of 2 kN to the wall at approximately 1100 – 1200 mm above ground, which is approximately two thirds of the cattle height. Using standard tables (SABS, 2010c), computations showed that using 100 mm diameter planted posts and 50 mm stranding poles spaced at 3000 mm and 380 mm centre to centre respectively, translates to a resistance of 0.6 kN load and a bending moment of 11 kNm. A safety factor of 1.3 was used in the design process and a 30 MPa concrete mix for all concrete works was assumed. Appendix A contains the design notes and the final specification for the boxed shaped crush. It was also further recommended to make use of the box crush orientation for structural stability as it is the most capable for resisting both tensional and compressive stresses associated with cattle facilities, as advocated by Longhorn (2010). The detailed assumptions and design calculations are contained in Appendix A.

Further design computations contained in Appendix A were undertaken to determine the characteristics of the catwalk/platform on the box shaped crush side. It is found that 50 mm square tubing is an appropriate size for the support frame and 40 mm square tubing for the base frames (SANS Standards, 2010). The design notes in Appendix A contain the detailed specifications obtained from the ISO, SANS and SABS design standards for structural components (HDGASA, 2010).

Figure 4.3 is a pictorial sketch of the designed box shaped crush. Detailed design drawings, specifications and construction procedures are contained in Appendices A and B. Appendix A contains the detailed design notes and Figure 10.1 in Appendix B contains a detailed drawing, specification document, material list and construction procedure document of the boxed shaped crush. It also contains a virtual prototype of the proposed box shaped crush assembly for design visualisation by the client and end users.

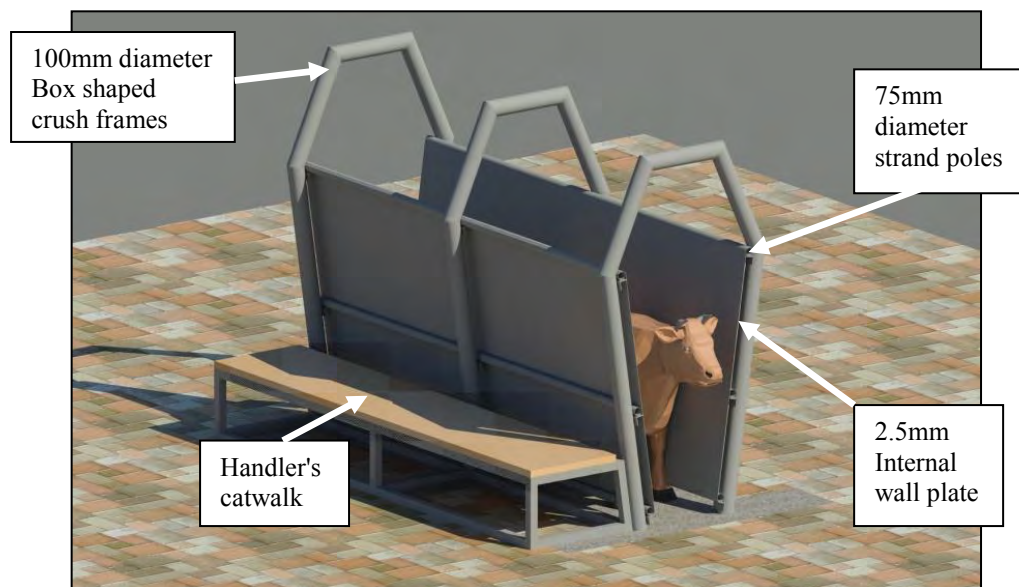

Figure 4.3 Pictorial view of the proposed box shaped crush

#### 4.4 Cattle Flow Control Design

Cattle flow control is of importance to ensure smooth flow of operations in a handling system. This section provides details of the flow control requirements, recommendation and designs.



#### **4.4.1 Design Problems in the Existing Manual Systems**

Appendix A contains a summary of the problems encountered with current manual flow control systems, as summarised in CIGR (1984), CIGR (1992) and CIGR (1994) animal housing reports; also confirmed by Weeks *et al.* (2002) and Bowling *et al.* (2008).

#### **4.4.2 Design Solutions**

The design notes in Appendix A contain the design solutions to the design problems based on literature surveys and design computations to select the best alternative.

In order to have better animal control along the crush, it is important to have a flow control system at the mouth of the box shaped crush for regulation of movement. It was concluded that a combination of split gates and sliding gates resulted in improved practice assuming an animal speed of 1-2 m.s<sup>-1</sup>. Automation results in both quicker and more accurate handling and easier integration with other tasks. Appendix A2 contains the synthesised specification of the design which indicates the proposed solutions to uncontrollable cattle flow, stressful and noisy gate operations and speed regulation whilst minimising injuries to the animals.

Mechanical, pneumatic and hydraulic actuated automation systems were considered as possible alternatives. Pneumatic actuated automation was selected and Appendix A2 contains the selection considerations used in the design process. Standardised compressed air rams were recommended by many experts in the automation field due to their flexibility and ease of operations (Racewell, 2010). The standard ISO 6431 type DNC/DKE supplied locally by Festo (2010) was found to be the most appropriate system to use in this kind of operation (McCauill, 2011). Appendix A2 contains the final specification of the gate automation. The detailed selection process is illustrated and contained in Appendix A2.

Figure 4.4 is a pictorial sketch of the flow control double split gates. Details of the design drawings, specification, construction procedures and virtual prototype are contained in Appendix A2 and Figure 10.2 in Appendix B2 contains a detailed drawing, specification document, material list and construction procedure for the flow control double split gates.

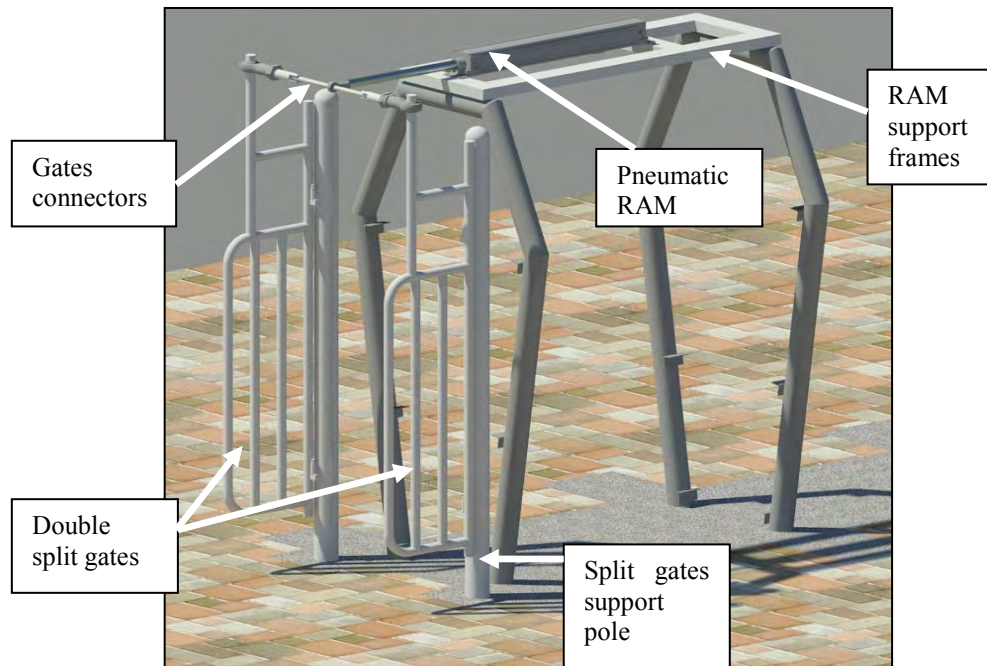

Figure 4.4 Flow control double split gates

## 4.5 Cattle Sliding Gates System Design

These gates serve the purpose of restricting flow and anti-backing of cattle movements and enhance flow patterns and smooth operations. This section provides detail designs of the gates system.

### 4.5.1 Design Problems in the Existing Manual Systems

Appendix A3 contains a list of the sliding gate system design problem areas and details which were obtained from the study undertaken by the ARC-IAE (Mutenje, 2009).

#### **4.5.2 Design and Final Specifications**

A sliding gate system is the most widely used system for closing and opening narrow cattle lanes or races (Grandin, 1993). The functions of the sliding gates are to block and to limit baulking and back tracking. A sliding gate system is typically used in places where there is limited room and where a traditional swing gate would pose an obstruction in its open position.

There are three main actuated types of sliding gates that can be utilised, i.e. manually operated, pneumatic gates (single unit) and pneumatic split gates (double leaf). Due to cost restrictions and effectiveness of operations, a pneumatic gate system was selected for this system.

Compressed air rams supplied by Festos (2010), incorporated with automation control systems from Omron (2010), were utilised in this project. This information was also verified by computations as detailed in Appendix A3 which also contains detailed solutions adopted for the above problem. Appendix A3 contains the design solutions to the above mentioned design problems, extracted from Appendix A design notes.

Figure 4.5 shows a pictorial sketch of the design cattle sliding gates system. Details of the design drawings, specifications and construction procedure are contained in Appendix A3 and Figure 10.3 in Appendix B3 contains a detailed drawing, specification document, material list and construction procedure for the flow control double split gates.

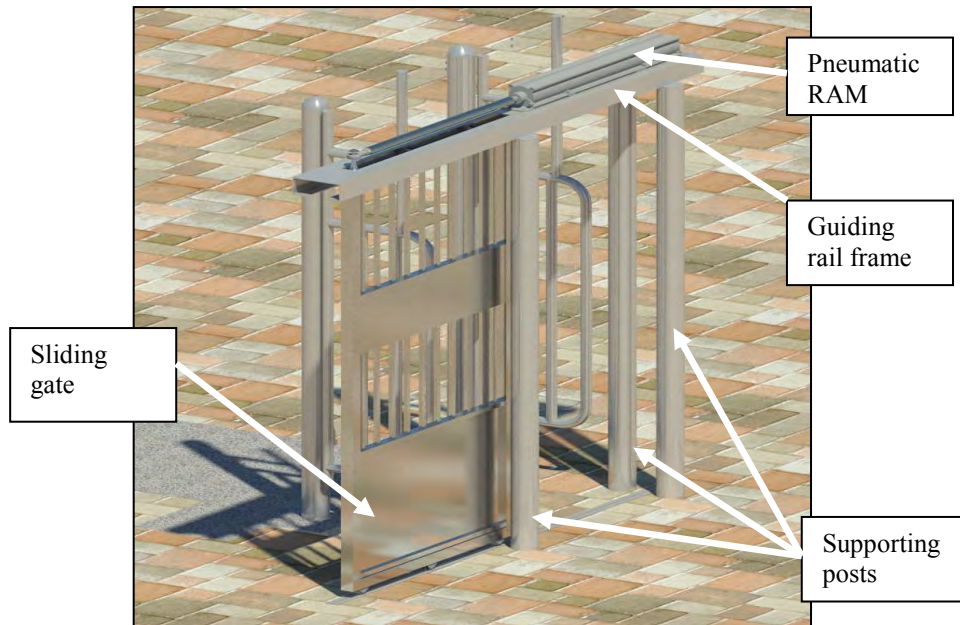

Figure 4.5 Cattle sliding gates system

The sliding gates are installed to act as boundaries of the identification and weigh box both at entrance and exit. The components that require design consideration include the identification and weigh box.

## 4.6 Identification and Weigh Box Design

This is the most important section of cattle handling where the animal is identified and animal specific data is captured. If the operation is undertaken incorrectly, it might result in poor management practices and result in a waste of resources. Appendix A4 contains a detailed design report of these systems.

### 4.6.1 Design Problems in the Existing Manual Systems

The design notes in Appendix A4 contains a list of problems in the identification of animals and weigh box currently experienced with manually operated systems.

### 4.6.2 Detailed Design and Final Specifications

Although RFID tags are a more efficient system for cattle identification, it is necessary

to make use of visual tags in case of electronic failure. It is more advantageous to make use of panel readers for identification as compared to stick readers, as they have a bigger reading surface area. From computations and experimentations reported, it was concluded that for efficient system flow it is necessary to make use of the 132.4 kHz frequency compliant weighing and display units (Cox *et al*, 2006).

In order to realise the benefits of electronic sorting and management system, management software should be incorporated. The benefits of automation can be negated by delays in the conveyance of an instruction to open or shut a gate. Although automation has advantages in management practices, it is necessary to investigate the financial and logistical challenges associated with these systems.

The design solutions of the identification and weighing system, with more details in Appendix A4.

Figure 4.6 is a rendered image of the designed identification and weighing system. Details of the design calculations, drawings, specifications and construction procedure are contained in Appendix A4 and Figure 10.4 in Appendix B4 contains a detailed drawing, specification document, material list and construction procedure for the cattle identification and weigh box.

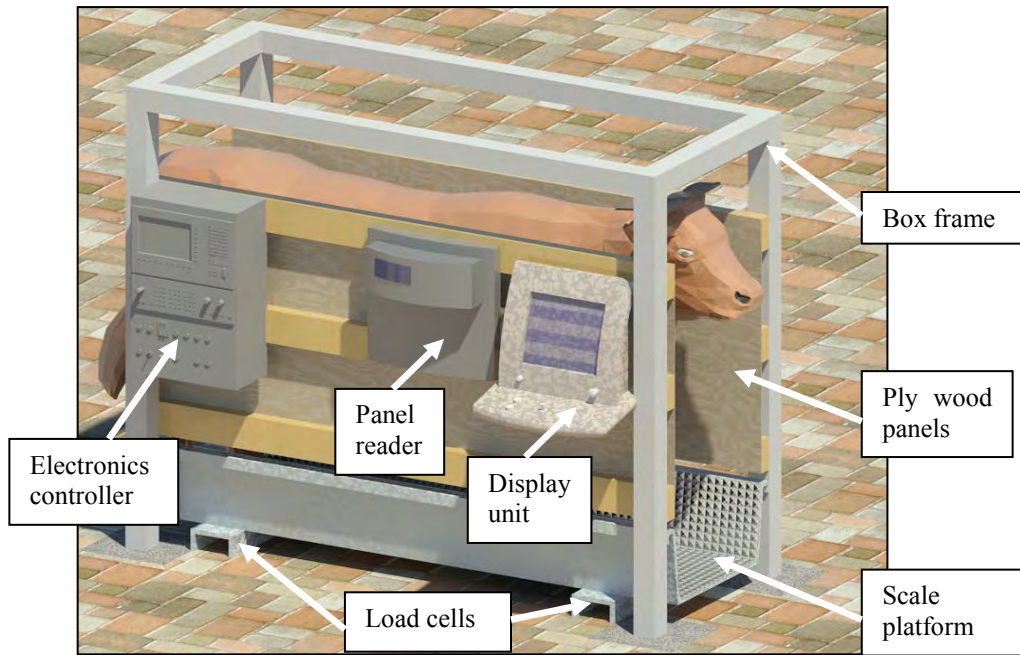

Figure 4.6 Cattle identification and weigh box

#### 4.7 Cattle Restraining System Selection

Cattle restraining mechanisms, commonly referred to as a crush, can generally be described as side frames between which cattle are driven and both neck and body are restrained for working purposes. This system enables an animal to be worked on in an upright position. Crushes normally are approximately 2 m long, 2 m high with 0.7 m as minimum width.

##### 4.7.1 Design Problems in the Existing Manual Systems

Appendix A5 contains the design problem areas and design details associated with cattle restraining system, sometimes referred to as a neck and body clamp.

##### 4.7.2 Selection Criteria for the Restraining System

Although the restraining system was not part of the design process, it was selected based on the desired characteristics to ensure ethical management systems. These

characteristics include more efficient operated restrainers. This included a walk-through head bail at the mouth of the system to enable clamping of the animal at the system exit.

There should be a full height gate at the rear of the restrainers as an anti-backing system. It is important to have at least a 3 mm plate, welded or bolted in as a platform, for efficient cattle flow. These ideas are contained in the Taltec (2010) neck and body clamp characteristics brochure and manuals. Appendix A5 and Figure 4.7 contain the required characteristics of cattle restraining systems.

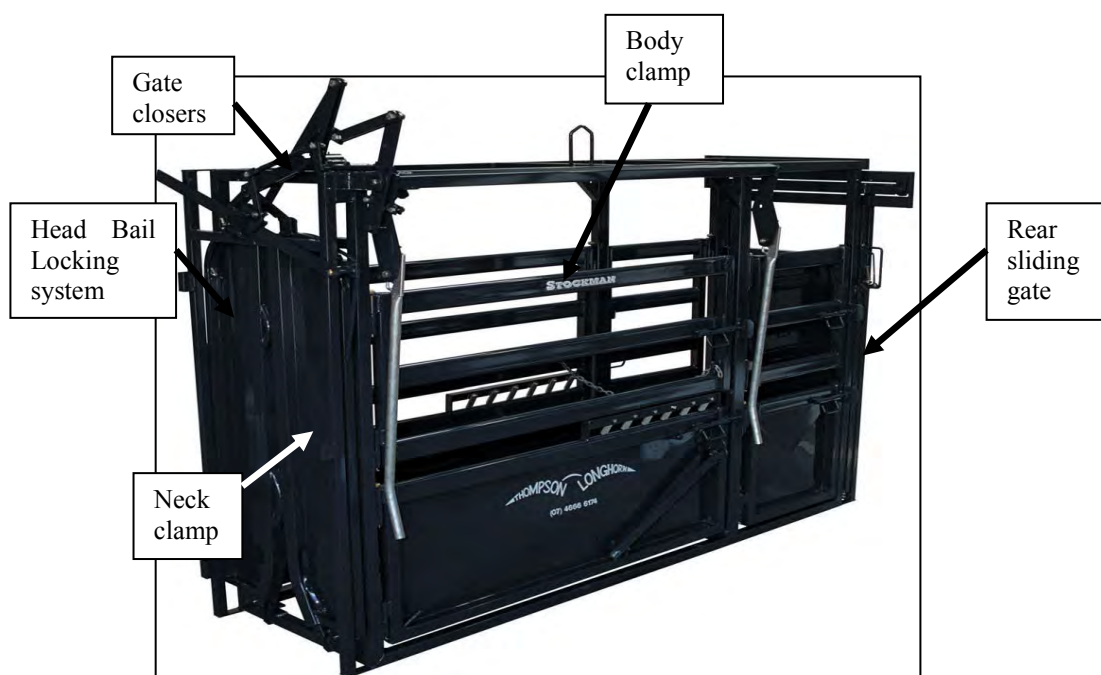

Figure 4.7 Photo of a neck and body clamp (Longhorn, 2010)

#### 4.8 Handler Access Gate Design

During the handling process at the restraining zone, it is important to be able to manoeuvre from one side to the other side during operations as there are operations that need to be undertaken on both sides of the animal. Access gate areas act as a transition zone from the restraining to the sorting system. The following section contains specifications for the handler access gates.

#### **4.8.1 Specification Requirements for the Handler Access Gates**

Appendix A6 contains the specification and design requirements of the handler access gates. These requirements formed the basis for the design.

#### **4.8.2 Selection Consideration for the Handler Access Gates**

Most of the operation in a cattle handling facility are undertaken on the right in the direction of movement, but the handler should have access from both sides. This passage not only serves as access to a handler, but also acts as a means of transferring handling equipment from one side to the other side. For efficient operation, the access gates passage should be at least 750 mm wide to allow items like computers and readers to be transferred from one side to the other side. From the literature it was established that gates should be at least 250 mm above the ground to avoid possible obstruction brought about by the gate sagging and as manure accumulates on the floor (Grandin, 2003). A height of 1500 mm above ground for fencing was selected for uniformity of the handling structure. The side gates of the handler access are to be made of solid sheeted material to inhibit cattle from exiting through it.

The SABS (2010a) recommends making use of a water proof and anti-corrosion finish for the components as it is likely to be exposed to manure containing ammonia. Figure 4.8 is a pictorial representation of the detailed specifications contained in Appendix A6 and in Appendix B6.



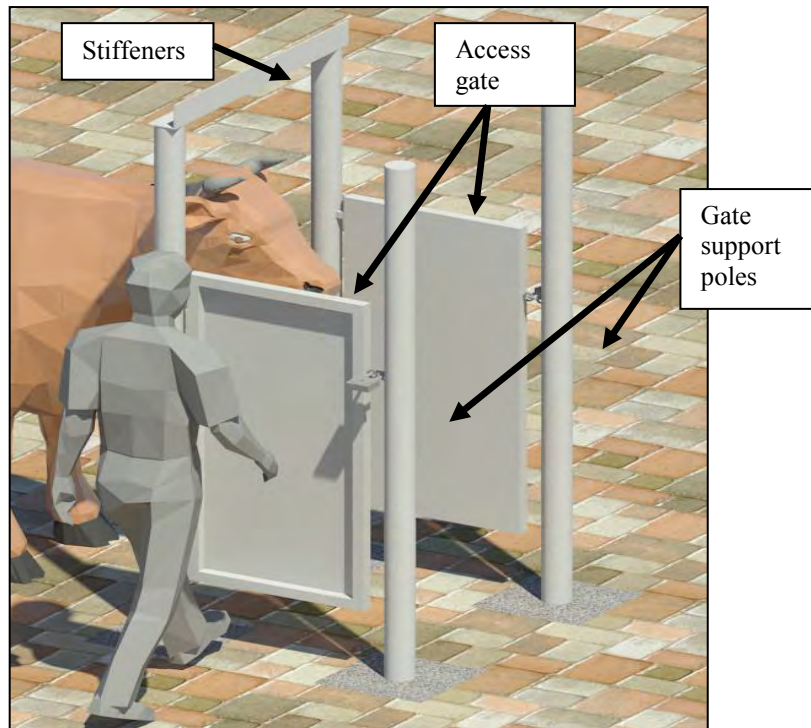

Figure 4.8 Rendered drawing of the handler access gates

#### **4.9 Automated Cattle Sorting System Design**

After cattle restraining has been carried out and a management decision has been made, the animal is then moved to the sorting system. The automated sorting system is at the centre of cattle handling as it serves to translate all the handling practise of the entire system into tangible results. In this section animals are sorted based on the management decision.

The system serves the purpose of translating a management decision into action. This section contains specification requirements for the automated sorting system for adequate system performance.

##### **4.9.1 Specification Requirements for the Cattle Sorting System**

Appendix A7 contains the specification and design requirements of the cattle sorting system.

#### **4.9.2 Selection Consideration and Computations**

For efficiency, a system was developed to incorporate state of the art technology that supports selective sorting of animals for various management reasons. Markets currently pay premium prices for animals within a particular mass range. The sorting system must be able to achieve sorting into three basic camps: for market, almost ready and still requiring constant feeding and monitoring. This will enable the forecasting of output schedules which will enable the feedlot operator to give advance notice to the market as to when the next groups of animals will reach the target mass.

Sorting gates passages should be at least 850 mm wide for efficient cattle flow. The gates should be 1650 mm long and 1000 mm high as this allows free animal movement whilst limiting turning back. As manure is deposited on the floor, accumulations can impact on to gate operation and thus a clearance of 250 mm below gates in the sorting system is necessary. The design for withstanding forces resulted in the use of a 100 mm square tubing support system for suspending the sorting system. The gates should be automated for both opening and closure as these gates are robust and are difficult to operate manually.

The use of management software and weighing systems that are compatible with the system is advisable. Gates can either be controlled from the management software or by remote activation. For cattle sorting systems, Challis (2010) recommends the use of 4 kN thrust and retreat air rams for gate controls. The same specification was confirmed by Omron (2010) for these kinds of operations. The gates should be 1500 mm high with a clearance of 250 mm above the ground.

Design specifications of the sorting systems are detailed in Appendix A7 and in Appendix B7 and a schematic representation is shown in Figure 4.9.

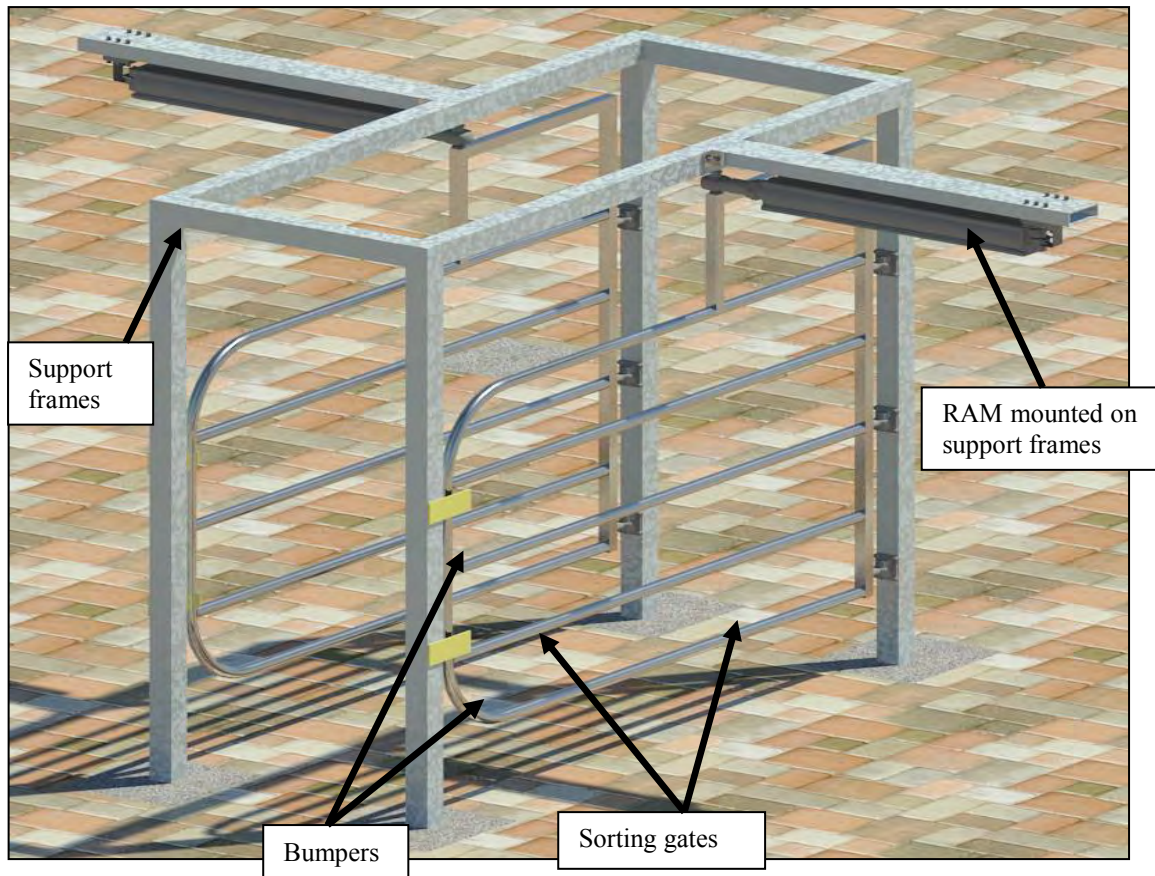

Figure 4.9 Automated pneumatic cattle sorting system

#### 4.10 Proposed Complete System Development and Evaluation Procedure

The conceptual design phase was followed by a detail design and computation phase which resulted in virtual prototypes and final designs of the following cattle handling system components:

- the box shaped crush system,
- cattle flow control system (double split gates),
- automated cattle sliding gates system,
- cattle identification and weighing system,
- cattle restraining system (neck and body clamp),
- cattle handler access gates, and
- pneumatic controlled automated cattle sorting system.

Detailed prototypes and design data were produced for all the design areas. Appendices

A7 and B7 contain the detailed designs and include the project funder's commentary on each component.

#### **4.11 Summary of the System Development Process and Way Forward**

Virtual engineering tools were utilised in the development of the RFID based cattle handling prototype system without physical modelling. This technological advancement facilitated the establishment of design challenges during the preliminary stages of prototype development. The design reports, contained in Appendices A and B, detail the standard design process followed by the development of the virtual prototype of the system.

With the aid of virtual tools the project funder was able to make informed decisions regarding the system outcomes in parallel with the design process and implementation procedure, which resulted in an acceptable prototype ready for fabrication and construction.

It was found that the virtual prototypes resulted in the visualisation of the end product and made it easy to visualize the specification. In addition, it illustrated construction procedures that were easily read and interpreted by the project funder. All of the above enabled informed decision making on the material, capital cost, space requirements and construction duration. In his literature review and proposal, Mutenje (2009) estimated that the whole RFID based cattle handling system would require, a capital cost of R 200 000, 110 man hours to construct, an area of 250 m<sup>2</sup> and a construction duration of approximately 12 weeks. The next chapter details the design modifications, fabrication, construction and evaluation process that was undertaken.

## 5. SYSTEM FABRICATION AND EVALUATION PROCESS

The system design phase was followed by the modifications to the design, fabrication, infrastructure construction and the evaluation process. After construction, testing was undertaken which resulted in the determination of performance parameters of the final system.

### 5.1 Design Modification Prior to Fabrication

In any research and development project, the end user's requirements must be incorporated throughout the design process. With the aid of the virtual prototypes produced for the entire system, researchers from the ARC-IAE were able to give their own assessment of the developed system and highlighted aspects which required further attention, as listed in Table 5.1.

Table 5.1 End-user design modification requirements

Item No.	Identified System Requirements	Proposed Design Alternatives
1	Portability (portable vs. fixed infrastructure)	It was concluded that there was need to modify the system design to enable the infrastructure to be portable.
2	Tagging before handling (Layout changes)	Researchers highlighted that it was necessary to tag the animal before any handling procedure, thus a restraining system needs to be placed before the handling system.
3	Pneumatic rams guiding system	Researchers highlighted that there was need to develop pneumatic systems that has precision positioning and guidance to avoid damaging equipment rather than free flow bores.
4	Modification for free-standing components	It was established that the requirement is to develop physical stand alone components , independent of each other on separate platforms .
5	Modification for ID-Weigh system to accommodate different animal sizes	Researchers highlighted that the design was to be modified to enable the handling of animals of different sizes, i.e. calves, weaners and adult animals which required modification to a tapered structure
6	Modification for minimisation of external interference	Researchers highlighted that there was need to modify the system such that see through infrastructure is minimised throughout the system.

Having discussed the above mentioned aspects there was the need to investigate and undertake design modification to satisfy the ARC-IAE’s requirements. Modification had to start with the layout changes to fulfil the ARC-IAE’s requirement to tag the animals before the handling system.

### 5.1.1 Layout Design Modification

Modifications to the design were made to ensure that cattle arrive into the handling system, are tagged and then handled. The details of the processes were widely and it was concluded that for efficient cattle movement it would be best if the infrastructure is subdivided into manual, semi-automated and automated processes.

Initially, the cattle would be confined to the restraining system from a portable alley passageway, from where they are passed to the flow control system. The flow control system was to be modified such that it is a stand-alone type with the capabilities of holding and controlling flow through a semi-automated pneumatic system.

Figure 5.1 shows the adopted modified layout as described above and which addresses the items listed in Table 5.1.

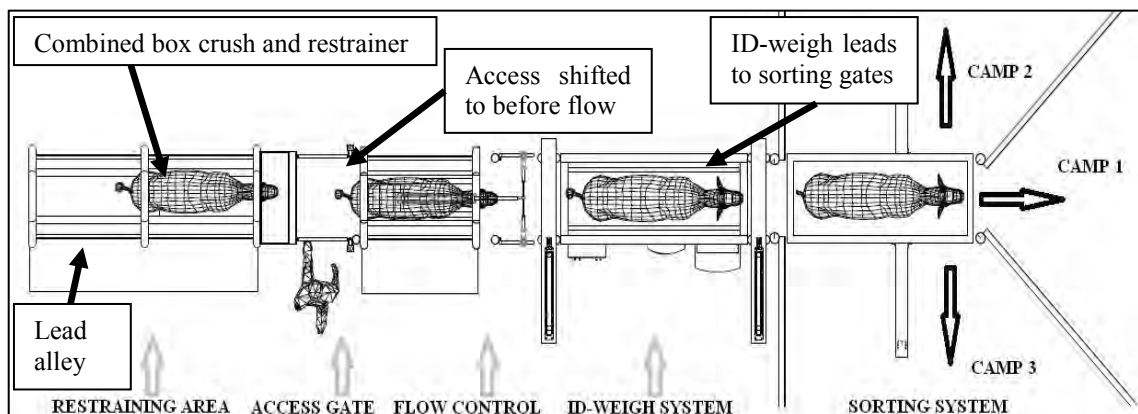

Figure 5.1 Revised layout of infrastructure

Design modification resulted in the adoption of the layout illustrated in Figure 5.1. An alley passageway illustrated in Figure 5.2, was developed to lead cattle into the

restraining system. A Taltec neck and body clamp (Taltec, 2010) illustrated in Figure 5.3 was chosen as the suitable restraining system installed between the restraining area and access gate. Detailed information on the complete infrastructure is contained in Appendix C.

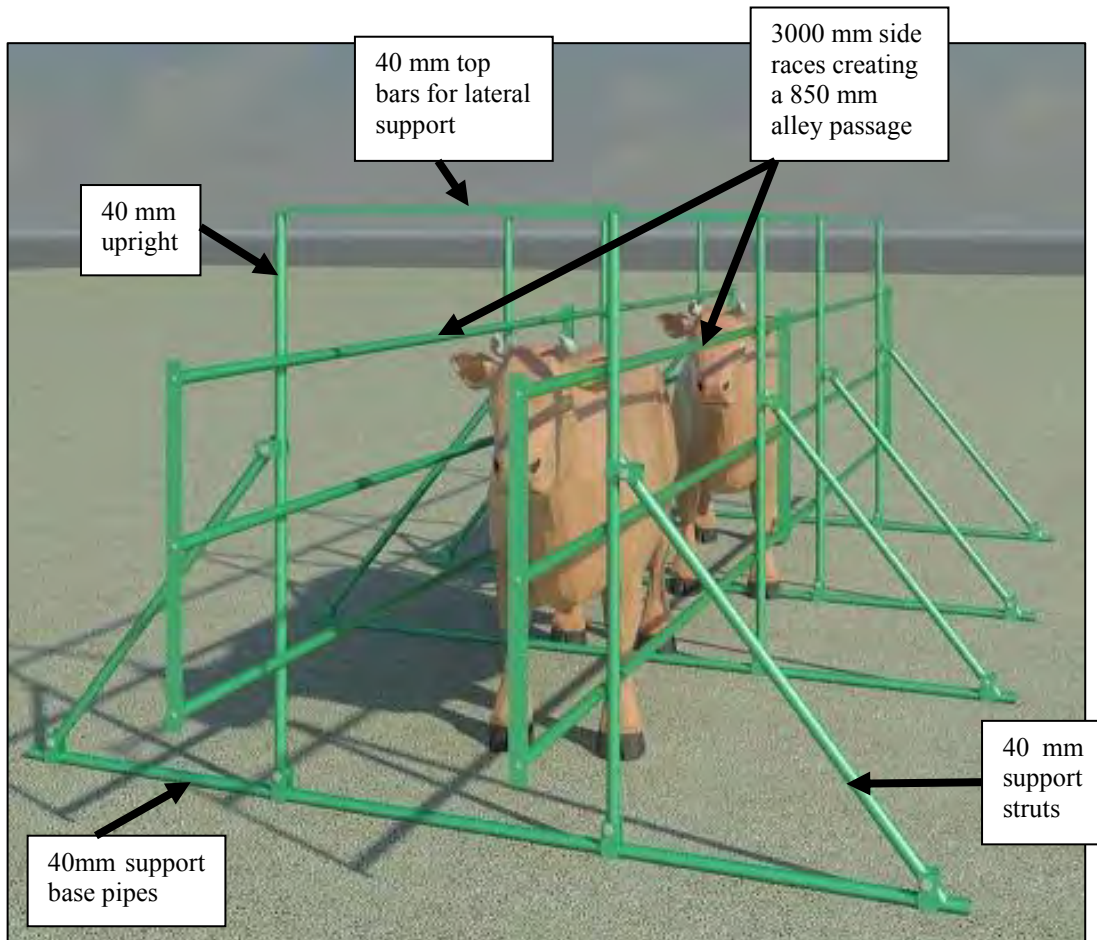

Figure 5.2 Final modified design of cattle lead alley passageway

The cattle lead alley passageway and restraining system also satisfied the client requirement of portability and enabled manual tagging before handling. Figure 5.3 shows the neck and body clamp that was adopted for use as the restraining system.

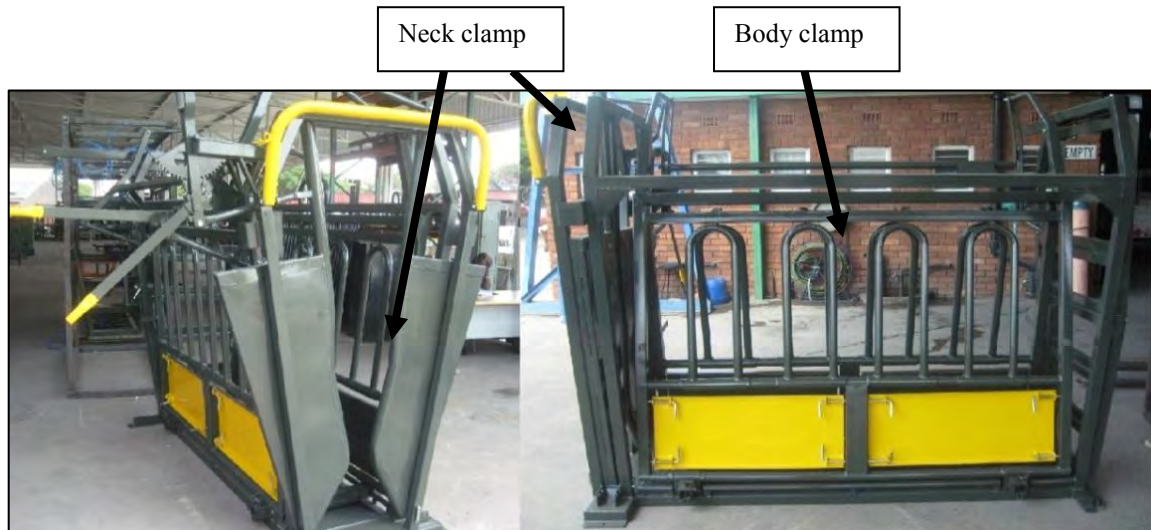

Figure 5.3 Views of the modified restraining system adopted (Taltec, 2010)

### 5.1.2 Handler Access Gates

The handler access gates design was modified to enable the access gates to be stand-alone and portable, as listed in Items 1 and 4 in Table 5.1. Table 5.2 and Figure 5.4 contain and show the design changes made for the handler access gates respectively, whilst Figure 5.5 is a photo representation of the end product.

Table 5.2 Handler access gates modifications

Item No.	Design Modification
1	Use of light mass 50 mm diameter steel tubes for portable structure stands
2	Infrastructure extended to full cow length to enable animal to stand in access gate before flow control system



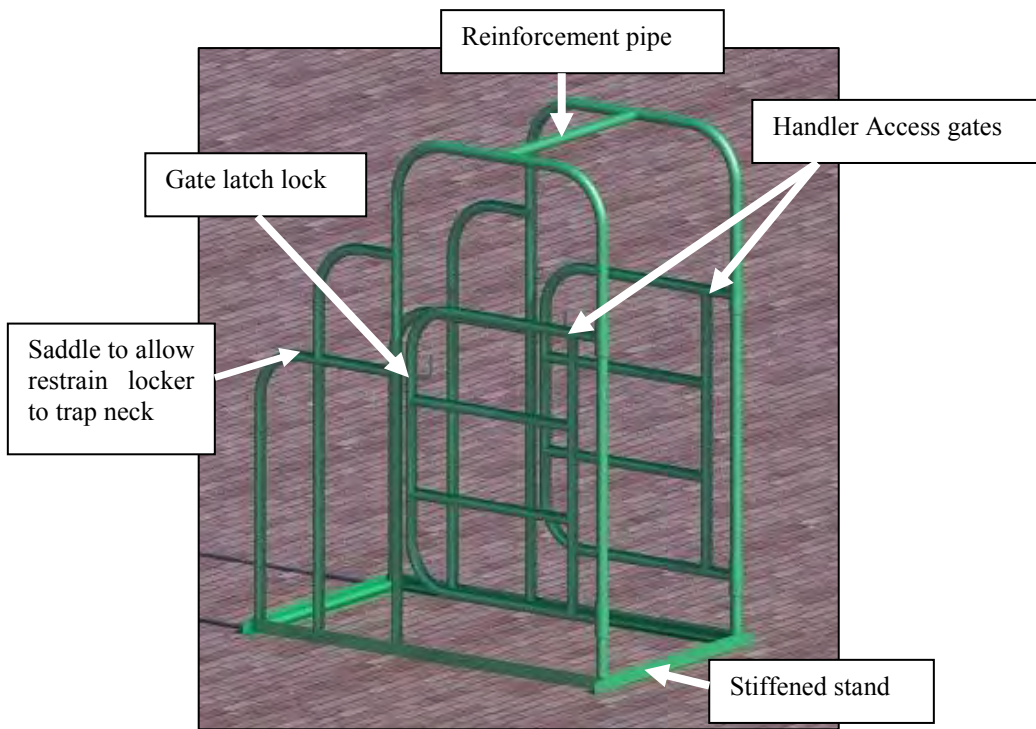

Figure 5.4 Final modified design of the handler access gates

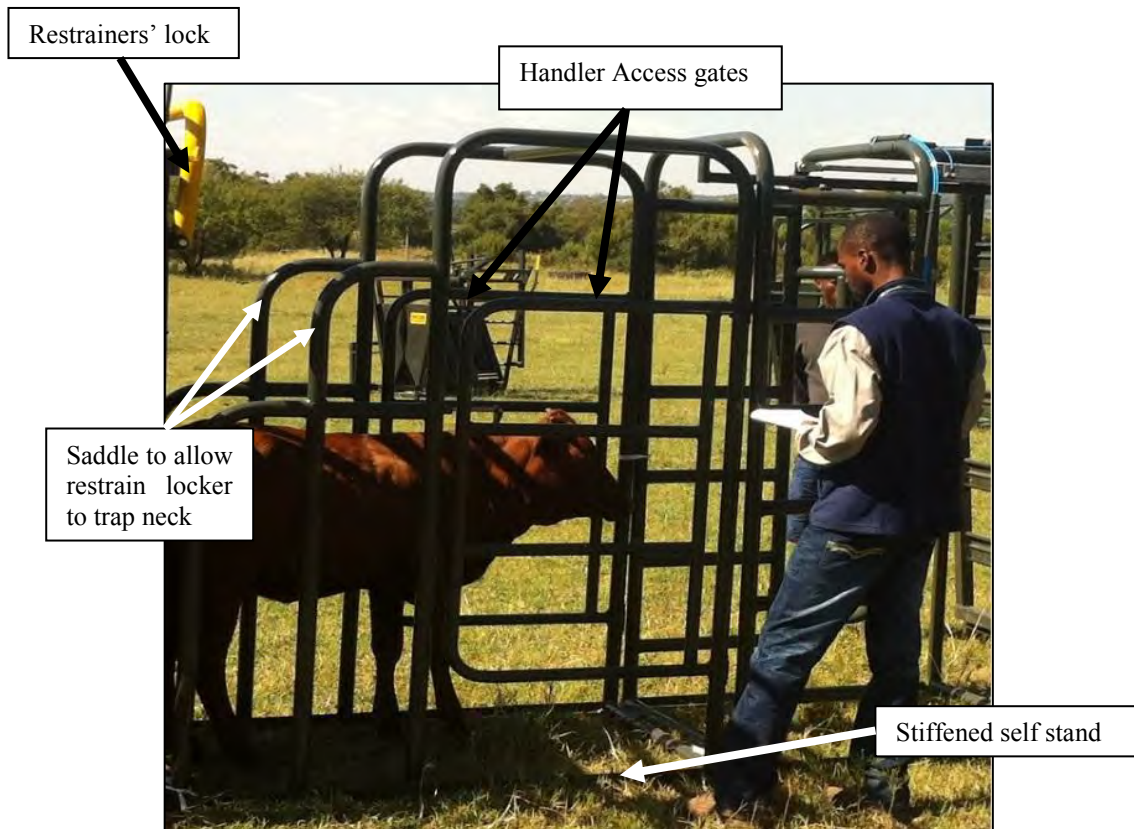

Figure 5.5 Operational handler access gate with cattle in alleyway

### 5.1.3 Flow Control Gate Design Modification

The double split gates design was modified to enable the flow control gates to be stand-alone, portable and pneumatically controlled, as listed in Items 1, 2 and 4 in Table 5.1. Table 5.3 and Figure 5.6 contain and show the design changes and the fabricated modified flow control double split gates system that was adopted for the infrastructure in order to address Items 3 and 4 as listed in Table 5.3.

Table 5.3 Flow control double split gates modifications

Item	Design Modification
1	Use of light mass 50 mm diameter steel tubes for portable structure stands
2	Pneumatic rams guiding system was introduced to minimise misalignment
3	Semi-automated air and electronics control was introduced to enable independent operations i.e. flow control system works independently of the ID-weigh automatic
4	Introduction of separate air control valve and handle for opening and closing as illustrated in Figure 5.6

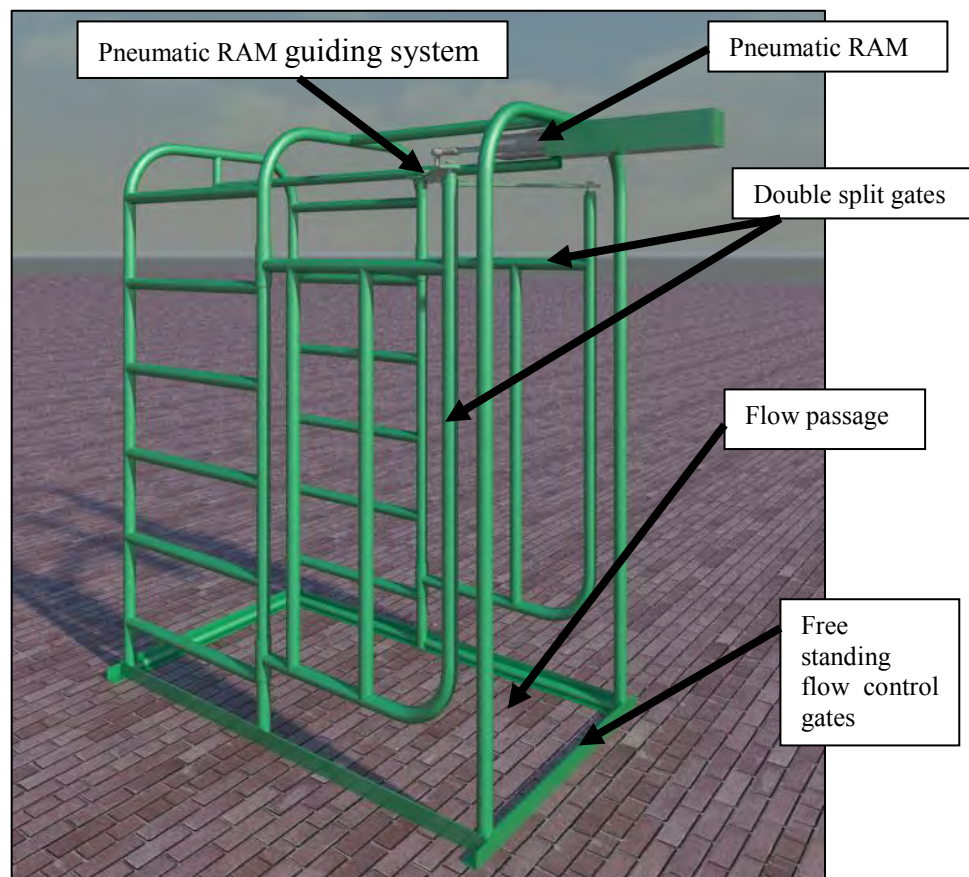

Figure 5.6 Final modified design of the flow control double split gates

Figure 5.7 is a photo of the end product during evaluation phase, after the fabrication and construction process.

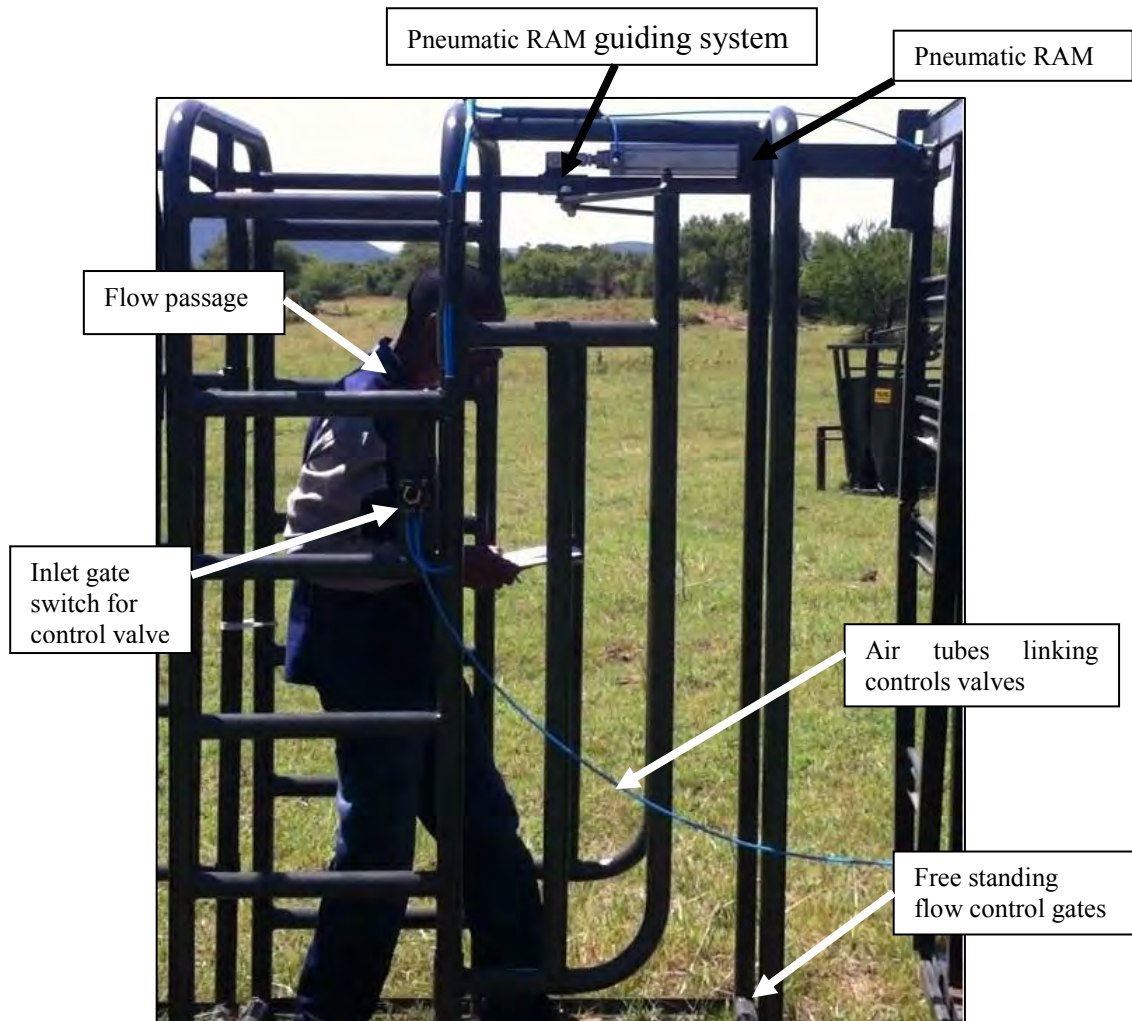

Figure 5.7 Flow control double split gates with automation and air control

#### 5.1.4 Identification and Weigh Box Design Modification

Due to the fact that the project funder highlighted the need to handle multi-size animals, the identification and weighing box was modified so that it caters for cattle of different age groups. Table 5.4 and Figure 5.8 contain and show the design changes and the pictorial representation of the end product respectively.

Table 5.4 ID-Weigh box design modifications

Item	Design Modification
1	Complete solid panels and walls to inhibit external interference
2	Tapered ID-Weigh box for multiple size handling
3	Fully suspended crate on robust 1010 mm load cells to increase accuracy of mass determination without external pressures altering the readings as the scale is zeroed at the suspended load
4	Automated sliding gates incorporated to improve accuracy

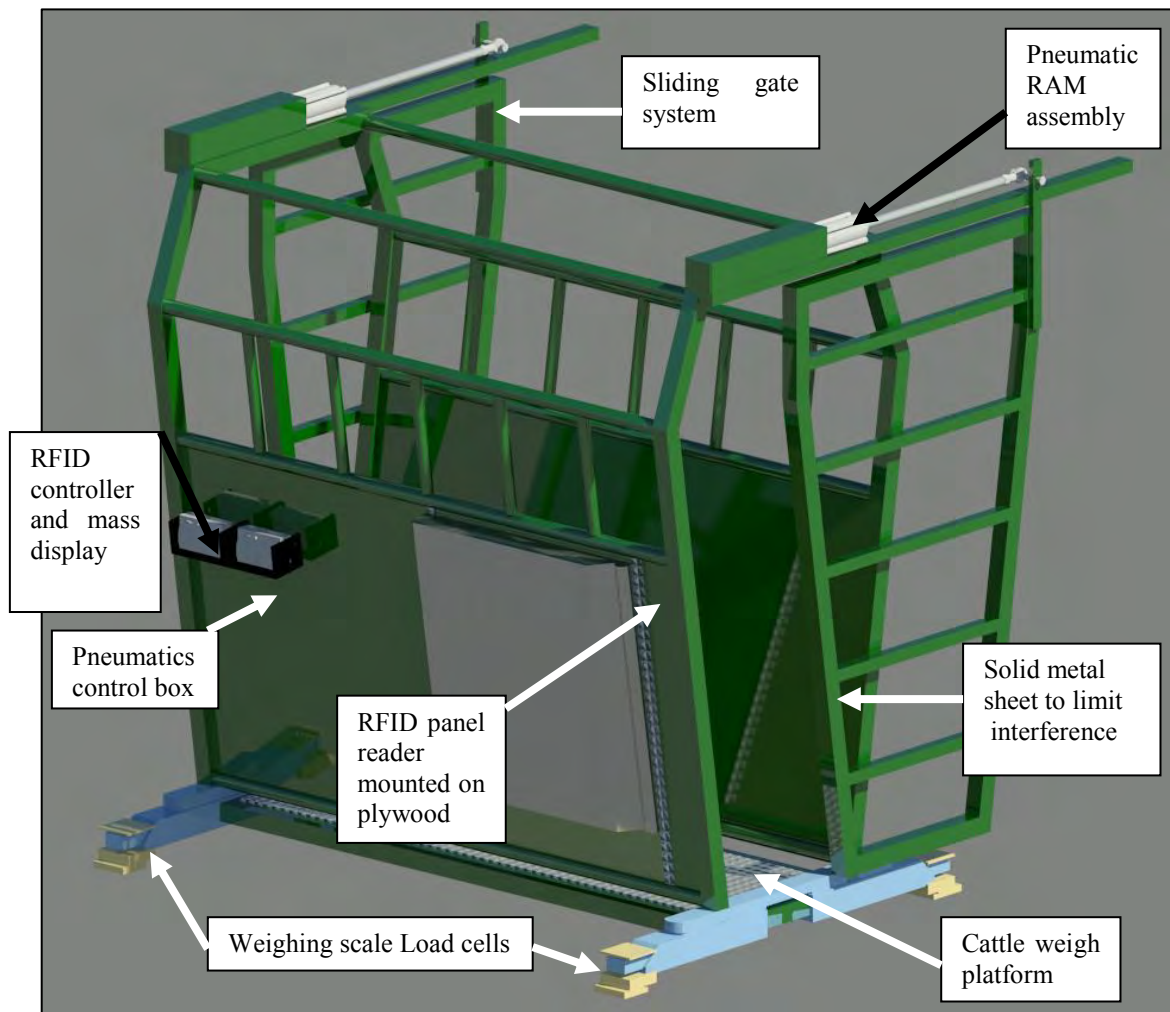

Figure 5.8 Final modified design of the identification weighing box assembly

Figure 5.9 shows the fabricated modified ID-Weigh system that was developed for the infrastructure.

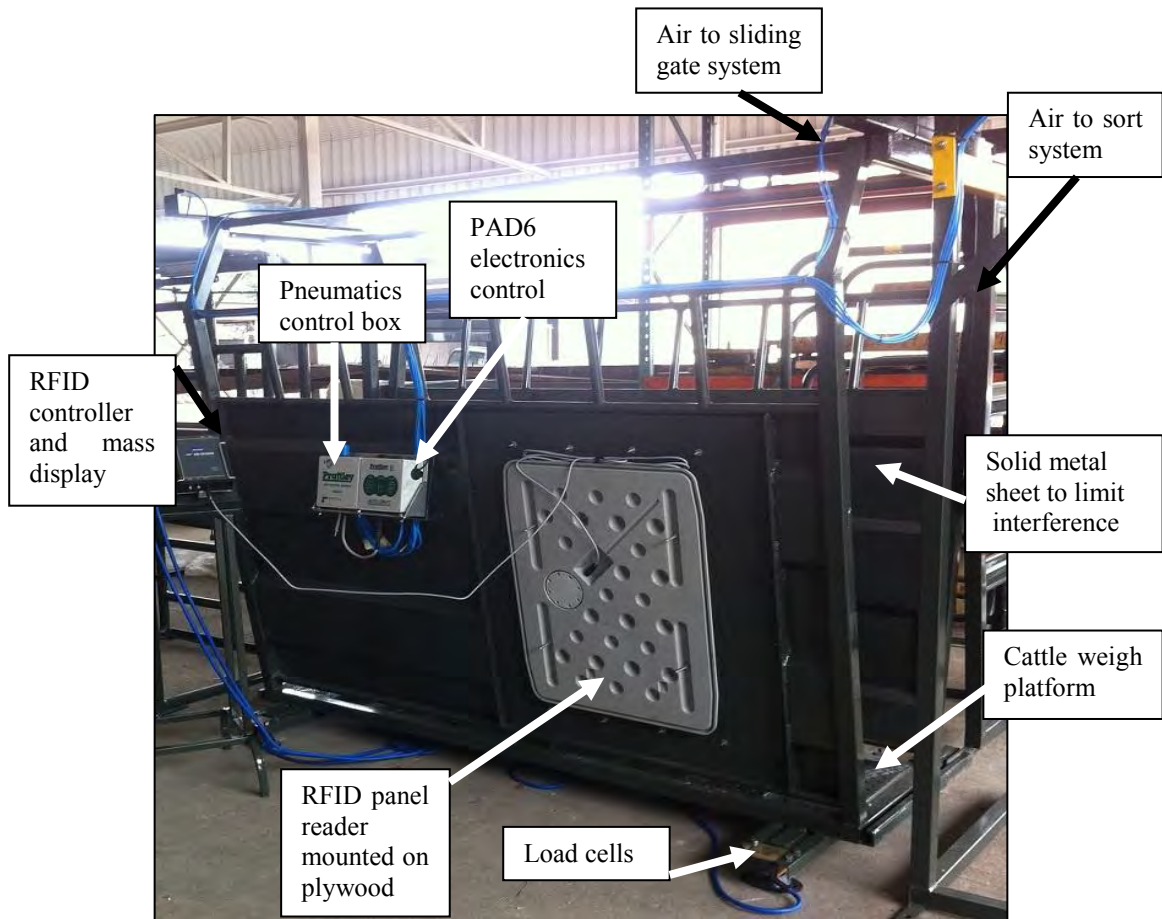

Figure 5.9 ID-Weigh box modifications and fabricated outcome

### 5.1.5 Automatic Sorting Gates Design Modification

Initial testing showed that it was possible for animals, when they are passing through the sorting system, to try to force themselves through the see-through gates. Thus, it was suggested that the walls be made up of solid panels to minimise this potential problem. Table 5.5 and Figure 5.10 contain and show the design changes and a pictorial representation of the end product respectively.

Table 5.5 Automated sorting gates modification and fabrication outcomes

Item	Design Modification
1	Complete solid panels and walls to inhibit external interference
2	Change of ram orientation to minimises air pressure and power requirements
3	Rubber bumpers for structure protection and stoppers
4	Full automation and control. No system reset to avoid injury to cattle should the animal stop along the way (With system reset the gates return to original position after sorting instruction is executed, which might result in cattle being injured should it fail to pass through before restore duration as it will be trapped against the walls)

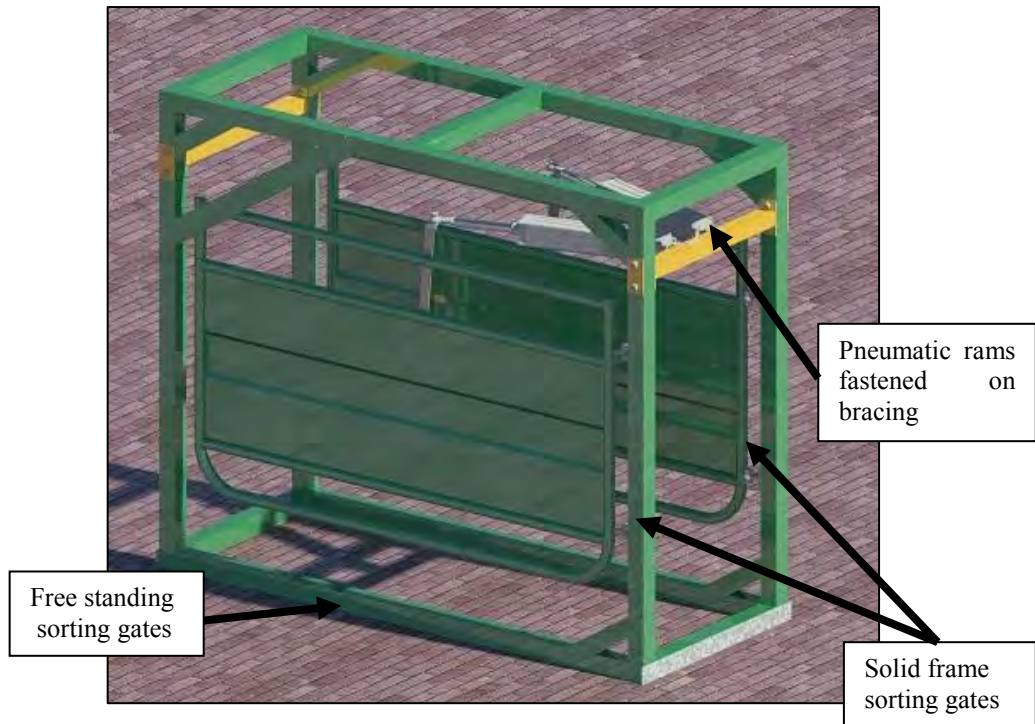

Figure 5.10 Final modified design of the automated sorting system

Figure 5.11 shows the fabricated modified automated sorting system that was adopted for the infrastructure.

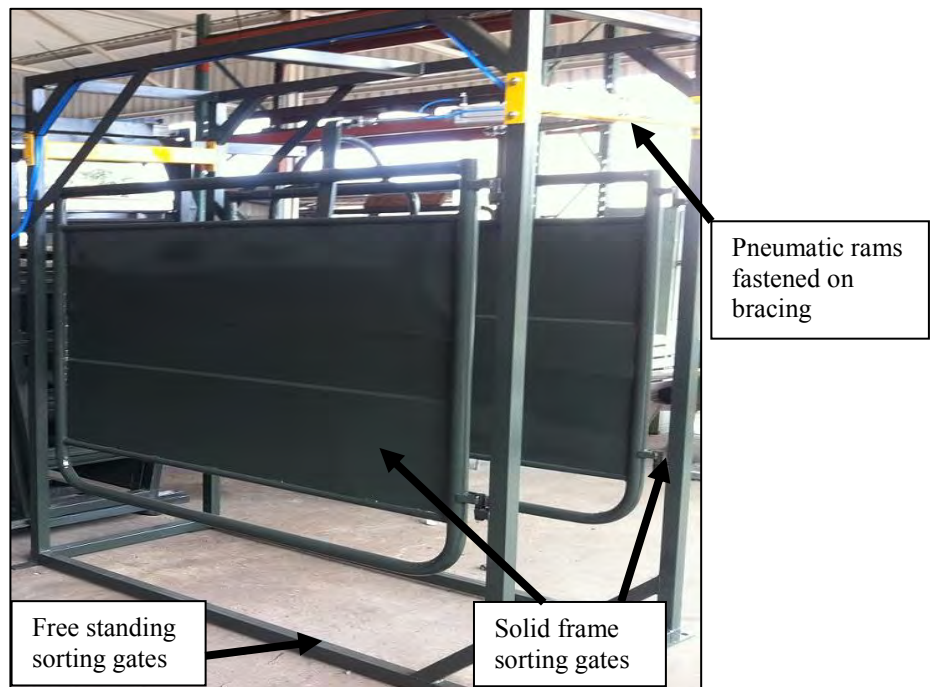

Figure 5.11 Automated sorting gates modification and fabrication outcomes

### 5.1.6 Ergonomics Evaluation

With any new technology development or improvement, it is necessary to evaluate whether the infrastructure is ergonomically friendly and compliant to animal management ethics (Fleming *et al.*, 2010). The important indices which required measurement were the stress and fatigue levels in both the animal and the operator (Grandin, 1994). It was realised that for comparison reasons there was a need to determine the stress levels in both operator and animal.

Research studies conducted at the University of Maribor, Slovenia (Janzekovic *et al.*, 2005) have shown the difficulty of establishing cattle stress levels directly. With this in mind, it was decided to measure the parameters associated with stress, i.e. breathing frequency and heart rate, and it was assumed that these would be adequate for this evaluation (Janzekovic *et al.*, 2005). For the determination of heart rate a modification of the Polar Sport Tester-Profi supplied by Polar electro Oy was utilised (Janzekovic *et al.*, 2005). The device comprises of a transmitter, with a tie down elastic belt. The tie down elastic belts were fitted with movable holders and a Bluetooth based computer interface, as illustrated in Figure 5.12. For efficient measurement a dual electrode system was used where one electrode was placed 10 cm offset from the central back line (behind the withers) and the other electrode in the pericardium area. Information was transferred from the Polar HR Analysis package into a Microsoft Excel spreadsheet.

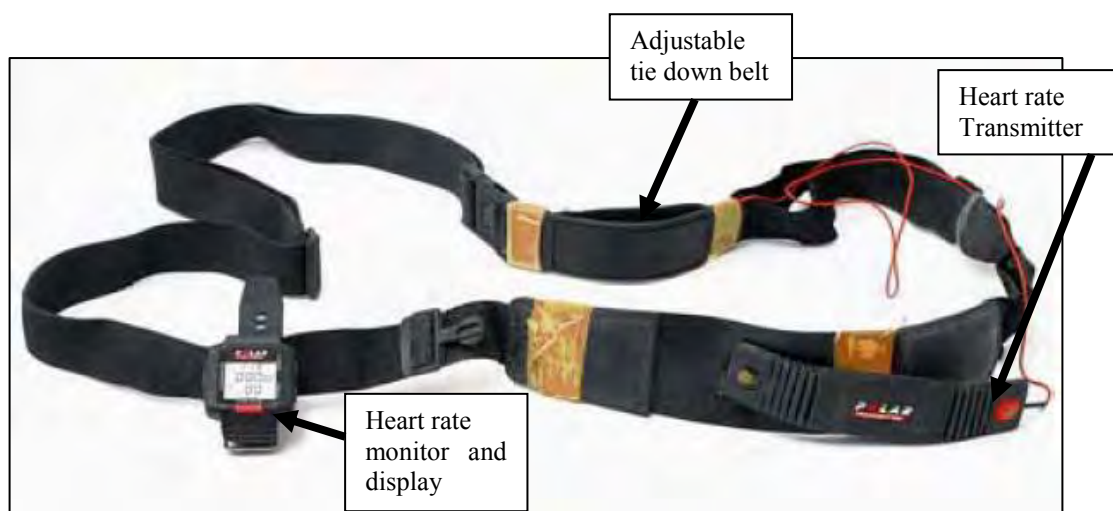

Figure 5.12 Modified Polar Sport Tester-Profi utilised for cattle stress measurement

Similarly, in order to measure the operator's exertion levels, a Polar sport test heart rate monitor model S-830 was utilised. Figure 5.13 shows the heart rate monitor that was utilised for the determination of the operator's exertion levels.

All other equipment for measuring parameters of importance like temperature (thermometer), relative humidity (hygrometer) and rainfall (rain gauge) were supplied by Axxon through their director in South Africa, Mr Chris Challis (Challis, 2011).

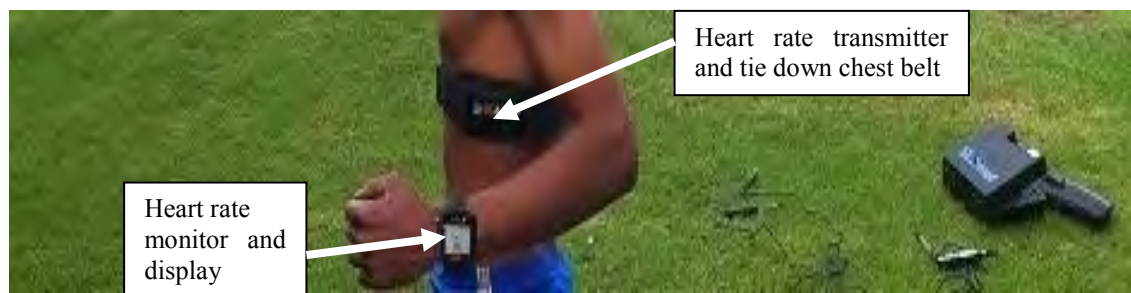

Figure 5.13 Polar Sport Test Heart-rate Monitor used for human exertion monitoring

## 5.2 Complete Fabricated and Constructed Infrastructure

The design modifications were incorporated into the final fabrication. The system comprised of six components namely, a lead passage alleyway, restraining system, handler access gates, flow control double split gate, ID-Weigh box and an automated sorting system, as illustrated in Figure 5.14.



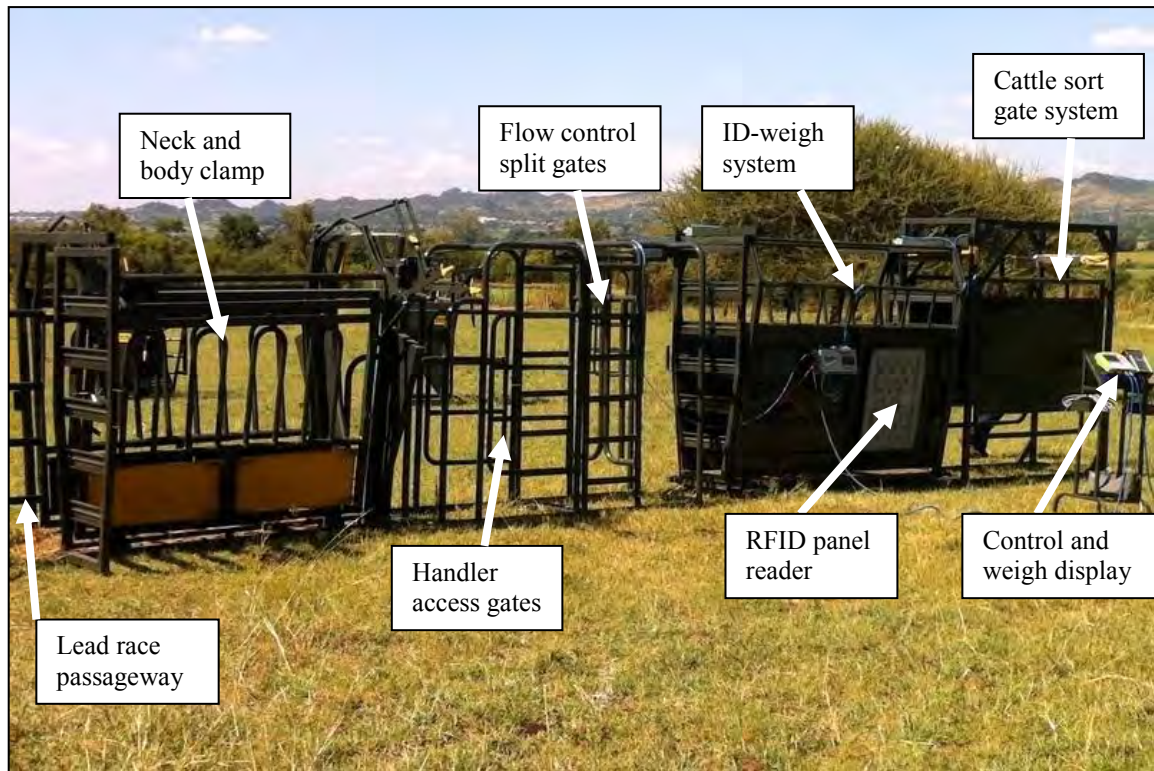

Figure 5.14 Complete portable, automated RFID based animal handling system

The fabrication and construction of individual components was undertaken by different service providers, as summarised in Table 5.6.

Table 5.6 Contributors to infrastructure development and evaluation

<b>Item</b>	<b>Details of Infrastructure</b>	<b>Service Provider</b>
1	All detailed design specification and bill of quantities. Design ideas. With the exception of box shaped crush assembly all the other infrastructures and components were fabricated by service providers	ARC-IAE Engineering Pretoria South Africa
2	Project coordination and equipment procurement	Axxon RSA (Challis, 2011)
3	Fabrication of restraining system	Taltec RSA (Taltec, 2010)
4	Fabrication of handler access gates	Taltec RSA (Taltec, 2010)
5	Fabrication of flow control double split gates	Taltec RSA (Taltec, 2010)
6	Fabrication of ID-Weigh box structural component	Taltec RSA (Taltec, 2010)
7	Fabrication of automated sorting system	Taltec RSA (Taltec, 2010)
8	Supply of automation control box	Pratley New Zealand (Ward, 2011)
9	Supply of pneumatic and air control box	Pratley New Zealand (Ward, 2011)
10	Supply of pneumatics, cylinders and accessories	Festo Australia (Festo, 2010)
11	Provision of farm and cattle for structure evaluation	Mr Greg Talbot RSA (Talbot, 2011)
12	Supply of heart rate, stress level and time equipment	Axxon RSA (Challis, 2011)
13	Supply of manual labour for infrastructure evaluation	Mr Greg Talbot RSA (Talbot, 2011)

The next chapter contains the comprehensive procedure and principles followed throughout the evaluation phase. These included evaluation for design compliance (in workshop) and practical evaluation (onsite).

## 6. EVALUATION PROCEDURES AND OUTCOMES

The infrastructure was evaluated for design compliance at the Taltec workshops and on a commercial farm located near Britz in the North West Province of South Africa courtesy of Mr. Greg Talbot, owner of Talbot beef cattle farm. The fabrication and workshop modifications were tested by intensive and rigorous on-site evaluation. The evaluation was undertaken with a sample size of 30 *Bonsmara* cattle, which are a cross breed produced for high quality meat production. Table 6.1 contains the geographical information of the evaluation site.

Table 6.1 Details of evaluation site

Site Details	Geographical Location	Elevation	Average Temperature	Rainfall and Relative Humidity
Mr G Talbot Farm: Beef Cattle	S 25° 03' 37.89" E 27° 44' 55.01"	1110 m	Morning: 14 °C Afternoon: 28 °C Evening: 21 °C	MAP = 540 mm Average RH=60%

The system was evaluated for both the automated electronics RFID based and the manual by-pass states. The manual bypass was to act as a control emulating conventional handling, which is currently widely practised in South Africa. Four basic aspects that direct impact on the efficiency of a handling system were monitored during the evaluation process and these were:

- handling duration which translates into man hours and operational costs,
- stress and fatigue levels in both animal and operator which impacts on meat quality and ergonomics,
- incorrect cattle sorting (selective sorting for marking strategies and admin), and
- overall efficiency which has an impact on business profitability.

The evaluation process was conducted over a period of 10 days. Evaluation procedures were undertaken three times per day i.e. in the morning (08:00), afternoon (12:00) and evening (04:00) from Day 1 to Day 10. A number of aspects were considered during the evaluation process as explained below. Raw data is contained in Appendix E.

## 6.1 Handling Duration Determination

Handling duration was defined as the time (s) that an animal spends in any stage of the handling system. A sample of 30 *Bonsmara* beef cattle was handled through the system in order to evaluate the handling performance. The total handling duration ( $T_{Total}$ ) is the sum of time spent in the flow passage, flow control gates, ID-weigh box and sorting.

Table 6.2 contains an explanation of the key areas where handling duration was measured for both the manual and automated states.

Table 6.2 Handling duration parameters

Item	Section	Purpose of Determination	Representation
1	Duration in flow passage	Duration of travel was utilised to determine the cattle flow speed in the passage way of known length	$T_a$ in s $v_a$ in $m.s^{-1}$
2	Duration in flow control gates	Duration taken from opening gate, cattle passing through to closing flow gate	$T_f$ in s
3	Duration in ID-weigh crate	Duration from opening rear gate, cattle entering, weighing, front gate opening, cattle exiting and up to when gate returns to closed default position	$T_{id-weigh}$ in s
4	Duration in sorting gates	Duration for decision, sorting and exit	$T_{sort}$ in s

The handling duration was determined through the use of a multi-lap stop watch. The watch was able to capture all the individual durations (flow passage, flow gates, ID-weigh and sort durations) as laps. Animals were passed through the handling system using both manually controlled and automated control. This process was repeated three times per day, in the morning, afternoon and evening.

The manual and automated procedures were repeated and alternated for a period of 10 days. In the reverse procedure the animals were first passed through the handling system in the manual by-pass state and then the automated states three times per day. The average handling durations of each procedure were then obtained and utilised to compute the savings in man hours, operational costs, system efficiencies and Cardiac

Cost of Work (*CCW*) and Cardiac Cost of Recovery (*CCR*) using the heart rate monitoring results. Details of how to compute *CCW* and *CCR* were explained in Section 2.5.2 paragraph 3.

## 6.2 Determination of Stress and Fatigue Levels

Stress levels in beef cattle have a direct impact on business profitability due to its negative effect on meat quality (Jandrow *et al.* 1982; Challis, 2011). As discussed in Chapter 2; stress levels on the animals were determined as a function of Breathing Frequency ( $f_b$ ) and Heart Rate ( $r_h$ ). For comparison of the two systems, maximum breathing frequency was calculated using Equation 6.1 (Varghese *et al.*, 1994).

$$\dots^{-0.251} \} \tag{6.1}$$

where

- $f_{maxx}$  = maximum expected breathing frequency (breath cycles per minute),
- 53 = mass breathing frequency constant, and
- $W$  = animal mass (kg).

Discomfort in an animal can easily be obtained by monitoring its heart rate as it is directly proportional to stress level in cattle (Grandin, 2010). From this statement from a leading researcher in animal production, the evaluation will compare the differences in heart rates and breathing frequency as parameters defining stress level in the cattle through both the manual and automated systems. Breathing frequency was obtained by measuring the time for 15 flank movements.

For analysis purposes, the operator was allowed to undertake work for a period of twenty minutes followed by a five minutes rest period. During the rest period the heart rate parameters were monitored and recorded for further analysis.

### 6.3 Accuracy of the Cattle Sorting System

The cattle were selectively sorted into three different camps on a mass and mass gain basis. The defined mass categories used are summarised in Table 6.3

Table 6.3 Sorting categories schedules and directions

Item No.	Mass Category (kg)	Sorting Camp	Sorting Purpose
1	0.0 – 100.0	Camp 3 - Right	Feedlot Entry : Feed
2	100.5 – 300	Camp 2 - Left	Transition Zone : Maintain
3	300.5 - 650	Camp 1 - Straight	Market Requirement : Market ready

Selective sorting was considered as one of the critical aspects of system performance. In cattle feedlots, it is important to sort the animals correctly based on their live mass as this controls market readiness of an animal. Incorrect sorting on a mass basis has negative impacts as many abattoirs require animals of a certain mass category for market.

Mass gain is also useful for animal performance assessment and thus incorrect sorting results in distorted outcomes. Animals were passed through the sorting system both in the manual and automated modes. After the animals were sorted, they were re-weighed in order to evaluate the correctness of the sorting. The number of incorrectly sorted animals was expressed as a percentage of the total number of animals handled, thus obtaining an incorrect reading percentages denoted by  $R_{incorrect}$ .

### 6.4 System Efficiency Determination

The overall Technical system Efficiency ( $TE$ ) was determined by computing difference aspects of the two systems, i.e. handling duration, operational man hour costs, Physiological Cost of Work ( $PCW$ ) and Energy Expenditure ( $EE$ ) in each operational mode.  $PCW$  was determined as a function of Total Cardiac Cost of Work ( $TCCW$ ) and

the total time of the activity in minutes.

Workload classification for humans by Varghese *et al.* (1994) was used to determine the physiological workload, as defined in Table 6.4

Table 6.4 Physiological workload classification (Varghese *et al.*, 1994)

Item No.	Workload Classification	Heart rate (beats .min <sup>-1</sup> )	Energy Expenditure (kJ.min <sup>-1</sup> )
1	Very Light	Up to 90	Up to 5.0
2	Light	91 – 105	5.1 - 7.5
3	Moderately Heavy	106 -120	7.6 - 10
4	Heavy	121 -135	10.1- 12.5
5	Very Heavy	136 - 150	12.6 - 15.0
6	Extremely Heavy	Above 150	Above 15

A comparison was also undertaken to assess how the measured average heart rate during operation compared to the method developed Rodahl (1989), who established from experimentation that the maximum heart rate of a healthy human can be estimated using Equation 6.2 .

$$220 - A \} \tag{6.2}$$

where

$HR_{Max}$  = maximum expected heart rate (beats per min),

220 = constant, and

$A$  = age of the handler in years.

Utilising the Equation 6.2 an analysis was undertaken to assess how the average heart rate for the people operating the systems compared with results published in the literature.

The purpose of introducing automation and RFID technology into cattle handling was to increase the productivity of the handlers and to reduce stress in animals, thus the above mentioned aspects are important in the analysis of the physiological cost and circulatory stress of cattle handling.

Heart rate and duration analysis were combined to calculate the  $PCW$  ( $\text{beats}\cdot\text{min}^{-1}$ ) and  $EE$  ( $\text{kJ}\cdot\text{min}^{-1}$ ). According to Varghese *et al.* (1994),  $PCW$  can be defined as the impact of work activity on the handler, i.e. the extent to which a procedure affects the operator's physiological being and is computed using Equation 6.3 (Varghese *et al.*, 1994).

$PCW$  is an indication of how much the handling procedure costs in terms of physiological labour whilst  $EE$  indicates energy spent in work between the two systems and is computed using Equation 6.4 (Varghese *et al.*, 1994).

$$PCW = \left\{ \frac{TCCW}{T} \right\} \quad (6.3)$$

where

- $PCW$  = physiological cost of work (beats per min),
- $TCCW$  = total cardiac cost of work (beats per time activity), and
- $T$  = total activity time (min).

and

$$- \quad \} \quad (6.4)$$

where

- $EE$  = energy expenditure ( $\text{kJ}\cdot\text{min}^{-1}$ ),
- $HR$  = heart rate ( $\text{beats}\cdot\text{min}^{-1}$ ), and
- 8.72 = heart rate energy constant.

Other important parameters for the evaluation are the  $TCCW$ , estimated through the use of Equation 6.5 contained in Table 6.5 which was developed by Rodahl, (1989) and Varghese (1994) from studies on the ergonomics of agricultural operation and activities. Table 6.5 contains other key parameters and equations useful in their computation. In agricultural activities and cattle management systems, the level of technical efficiency is considered a more efficient way of determining effective system improvements (Fleming *et al.* 2010). According to Jandrow *et al.* (1982) Technical efficiency is the effectiveness with which a given set of inputs is used to produce an output. Cattle handling systems are said to be technically efficient if they produce the maximum output from the minimum quantity of inputs, such as labor, capital and



technology. Technical efficiency can be determined through the use of a predictor derived by Jandrow *et al.* (1982) and confirmed by Fleming *et al.* (2010). Computation of system technical efficiency is contained in Table 6.5.

Table 6.5 Equations for system technical efficiency (Jandrow *et al.*,1982)

Item No.	Parameter Details	Equation for Computation
1	<i>TCCW</i> : Total Cardiac Cost of Work	$TCCW = CCW + CCR \quad (6.5)$ where $CCW$ = Cardiac Cost of Work ( b/min), and $CCR$ = Cardiac Cost of Recovery (b/min)
2	<i>CCW</i> : Cardiac Cost of Work	$CCW = \frac{AHR}{T} \quad (6.6)$ where $AHR$ = Average Recovery HR (b/min/time activity ), and $T$ = Duration (min).
3	<i>CCR</i> : Cardiac Cost of Recovery	$CCR = \frac{ec - es}{T} \quad (6.7)$ where $AReCHR$ = Average Recovery Heart Rate , $AResHR$ = Average Resting Heart rate (b/min) ), and $T$ = Duration (min).
4	<i>TE</i> : Technical Efficiency of System	$TE = e^{-u_f} \quad (6.8)$ where $TE$ = Technical efficiency (decimal), and $u_f = \frac{EE}{PCW}$

## 6.5 Evaluation of the System

Throughout the evaluation process, a number of challenges and limitations were encountered. This led to a number of system modification and changes to procedures in order to execute the evaluation process.

## 6.6 Challenges and Solutions

Table 6.6 contains a list of challenges and limitations encountered during the system evaluation and intervention methods implemented to alleviate them.

Table 6.6 Intervention employed to address system limitations during evaluation

Item No	System Limitation	Intervention Methods
1	Cattle turning in alley passage way	Alley passageway width was reduced to 690-700 mm to limit cattle turning
2	Cows with calves reluctant to move	Calves were put ahead of cows in queue
3	Tagging proved difficult as the restraining system did not have a tight grip on the animal neck	A head locking mechanism was introduced to the neck and body clamp front to ensure cattle immobilisation
4	Cattle retreated as they approach noisy flow control gate air valve	A silencer was introduced to the air control valve of the flow control double split gates to minimise noise levels
5	Cattle fur and thick cattle skin resulted in difficulties of heart rate determination.	Kitchen salt mixed with luke warm water was applied to the monitor contact area to increase conductivity
6	Cattle were reluctant to flow smoothly in the system	Animals were run through the system five times without any management practice being undertaken to acclimatise the animals
7	Animals were locked by retracting gates due to slow locomotion speed	By-pass button was introduced on the drafting remote to free animals after being trapped as prevention was difficult to predict prior to activity. Sensors were found to be more expensive for the production system.
8	Incorrect scale readings due to external loading	Handlers were instructed not to lean on weigh box thus excluding external load
9	RFID system malfunction due to more than one tag being within range of the reader	Handlers were instructed not to have RFID tags in their possession before coming within 1.5 m from reader panel as this caused electronic collisions
10	Noisy sorting gates when opening	Rubber bumpers were introduced to minimise noise levels on gate opening
11	Signal loss for cattle heart rate monitoring	Heart rate transmitter was moved closer to the animal in alley parallel to cattle flow direction

## 6.7 Results

After evaluating the infrastructure three times per day (morning, afternoon and evening) for a period of ten days, daily system averages were computed for three of the days, i.e. Days 3, 6 and 10 with the results shown Figure 6.1 to Figure 6.3.

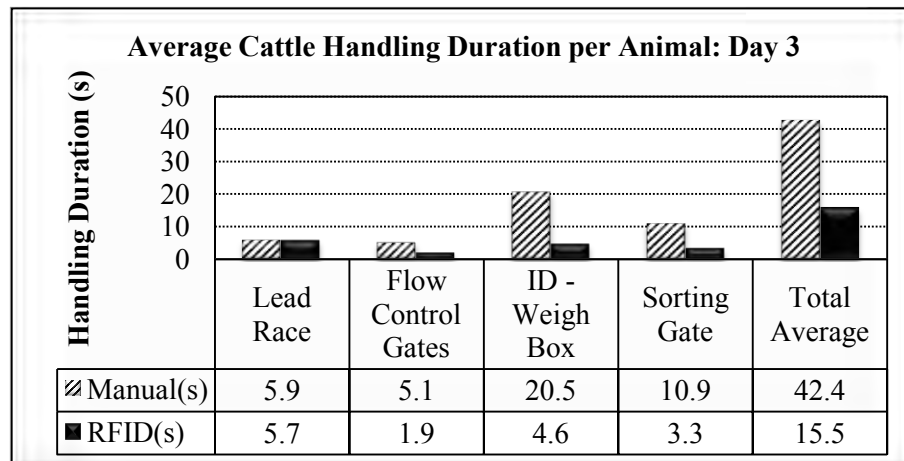

Figure 6.1 Average handling duration per animal for evaluations on Day 3

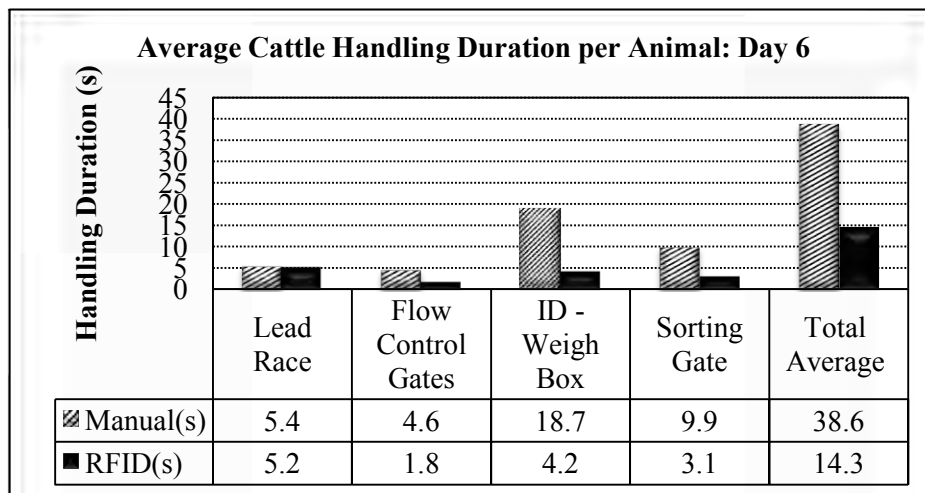

Figure 6.2 Average handling duration per animal for evaluations on Day 6

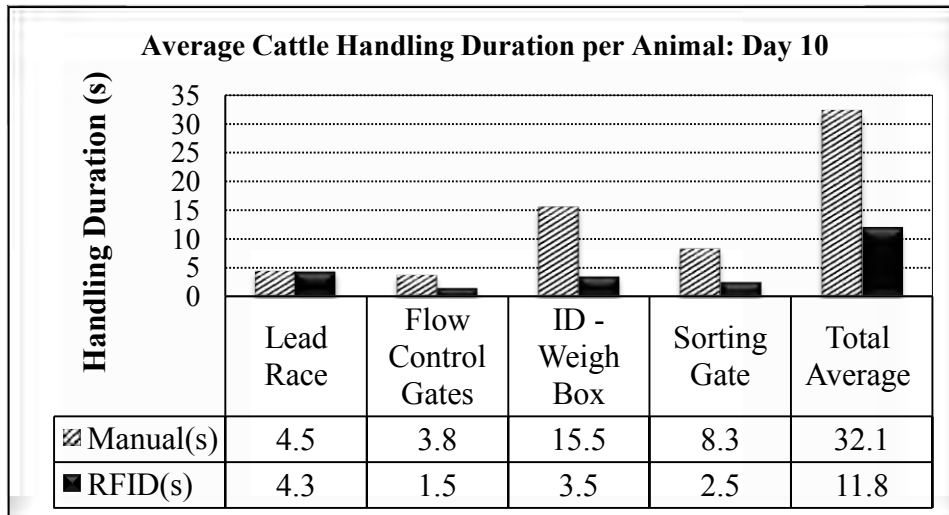

Figure 6.3 Average handling duration per animal for evaluations on Day 10

According to Grandin (2010), cattle require from 3-5 days to adapt to a new handling system. These results are confirmed in this study and, as shown in Figure 6.4, it took approximately 6 days for the animals to get used to the handling system. This is evident by the relatively constant total handling average duration of approximately 11 seconds and 32 seconds per animal for the RFID and manual based practices respectively for Days 7 to 10.

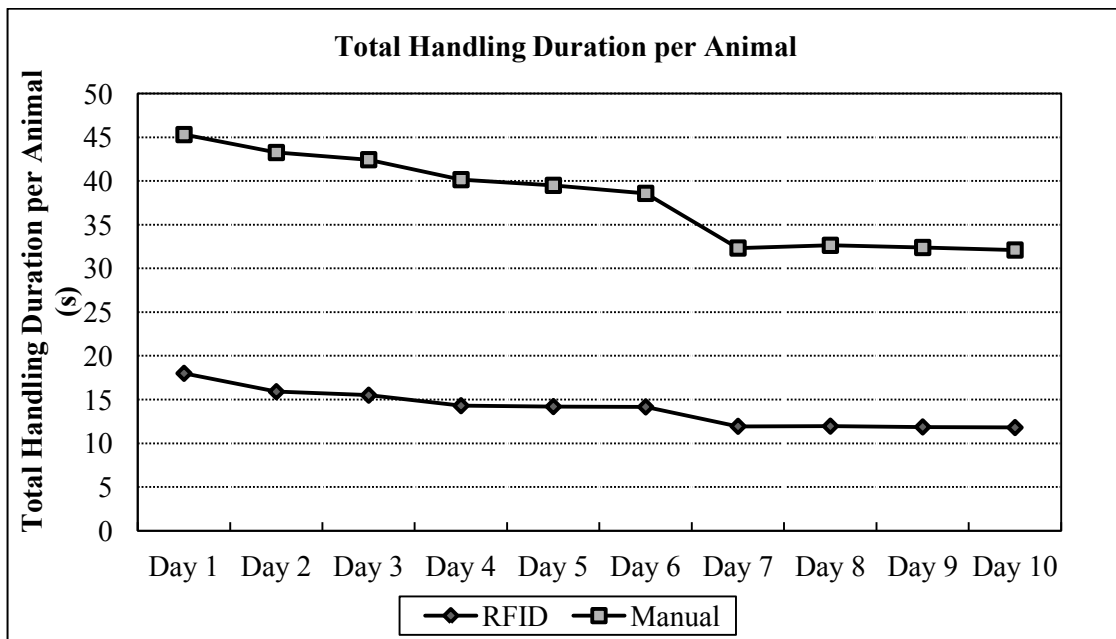

Figure 6.4 Total handling durations for the 10 days

Table 6.7 contains a summary of results from the evaluation process. It also includes a significance test of man hours saved by the use of the automated system. The RFID system required five men to operate while the manual system required three additional men to operate the front and rear gates of the ID-weigh box and recording section. Average total handling duration in Table 6.7 refers to the total time spent whilst animals pass through the system. This time is then multiplied by the number of men working in the system at the particular time to determine the average man hours for the handling process.

Table 6.7 Average handling duration for both systems

<b>Handling System</b>	<b>Day 10 Average Handling Duration/Animal</b>	<b>Average Total Handling Duration for 30 Animals</b>	<b>Average Man Hours for Handling 30 Animals</b>
Manual System	32.1 s	963 s	2.14 h (8 men)
RFID System	11.8 s	354 s	0.50 h (5 men)
Difference (s)*	23.9 s	609 s	1.64 h
Reduction (%)	63.2%	63.3%	77.0%

\*P < 0.0001

Using a two-tailed Student t-test for significance resulted in a statistically significant (P < 0.0001) difference in the average handling times per animal between the manual and automated RFID systems. Figure 6.5 contains an extract from Graph Pad InStat software that was utilised for the significance tests.

Paired t test			
Does the mean of the differences between Manual systems and Automated systems differ significantly from zero?			
<u>P value</u>			
The two-tailed P value is < 0.0001, considered extremely significant.			
t = 24.353 with 9 degrees of freedom.			
<u>95% confidence interval</u>			
Mean difference = 23.900 (Mean of paired differences)			
The 95% confidence interval of the difference: 21.680 to 26.120			
<u>Assumption test: Was the pairing effective?</u>			
Correlation coefficient (r) = 0.9760			
The one-tailed P value is < 0.0001, considered extremely significant.			
Effective pairing results in a significant correlation between the columns.			
With these data, the pairing (or matching) appears to be effective.			
<u>Assumption test: Are the differences sampled from a Gaussian distribution?</u>			
The paired t test assumes that the differences are sampled from a Gaussian distribution. This assumption is tested using the method of Kolmogorov and Smirnov:			
The Kolmogorov-Smirnov distance (KS) is 0.26			
The P value is 0.0618The data passed the normality test with P>0.05.			
Summary of Data			
Parameter:	Manual systems	Automated systems	Difference
Mean:	37.870	13.970	23.900
# of points:	10	10	10
Std deviation:	5.119	2.100	3.103
Std error:	1.619	0.6640	0.9814
Minimum:	32.100	11.800	20.300
Maximum:	45.300	18.000	27.400
Median:	39.050	14.200	24.850
Lower 95% CI:	34.208	12.468	21.680
Upper 95% CI:	41.532	15.472	26.120
	*	*	*

Figure 6.5 Significance test results extract from Graph Pad InStat software

### 6.7.1 Sorting Accuracy

During the handling procedure, incorrect sorting of cattle in the manual based system, was observed to range between 3-5%. Figure 6.6 shows the averaged daily number of incorrectly sorted animals experienced during the ten days evaluation period.

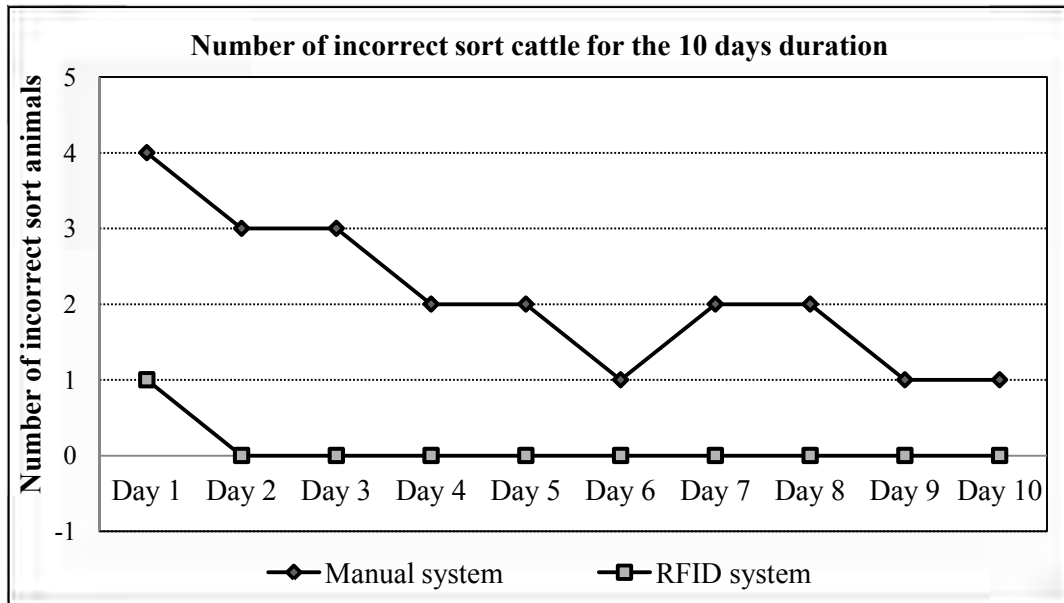

Figure 6.6 Averaged daily number of incorrectly sorted animals for the two systems

### 6.7.2 Work Physiology

Table 6.8 contains the characteristics of the five handlers that were involved in the ergonomic evaluation process.

Table 6.8 Characteristics of the handlers monitored

Item	Handler Characteristics	Average and Standard Deviation
1	Age (years)	31.50 ± 7.48
2	Height (m)	1.553 ± 0.0626
3	Mass (kg) measured by cattle load cells	53.52 ± 7.21

(5 Handlers were utilised for RFID System)

After the evaluation process with thirty cattle in both manual and automated systems in alternate procedures as described in the Chapter 4, the resting, handling and recovery heart rates were measured. These heart rates were utilised in the computation of the average and peak working heart rates, energy expenditure, total cardiac cost of work (beats per minute), physiological cost of work (beats per minute) and work load classification as per Varghese *et al.* (1994)'s categorisation of agricultural activities.

Table 6.9 contains the results for the manual handling system.

Table 6.9 Handler workload classification in manual cattle handling

Details	Observed Values		Computed Values				Conclusion
	Average Heart Rate (beats/minute)		Energy Expenditure (kJ/minute)		Average TCCW	Average PCW	
Operation	<i>Mean</i>	<i>Max</i>	<i>Mean</i>	<i>Max</i>	<i>(b/min)</i>	<i>(b/min)</i>	<i>Description</i>
Pre-work	87.54	89.75	4.39	4.95	443.62	11.09	Very Light
Handling	115.34	118.96	7.67	9.38	753.55	18.34	Moderately heavy
Post work	89.32	91.54	4.46	5.05	452.49	11.31	Very Light

After incorporating RFID automation and electronics control, the results contained in Table 6.10 were obtained.

Table 6.10 Handler workload classification in automated cattle handling

Details	Observed Values		Computed Values				Conclusion
	Average Heart Rate (beats/minute)		Energy Expenditure (kJ/minute)		Average TCCW	Average PCW	
Operation	<i>Mean</i>	<i>Maxi</i>	<i>Mean</i>	<i>Maxi</i>	<i>(b/min)</i>	<i>(b/min)</i>	<i>Description</i>
Pre-work	87.76	89.35	4.40	5.02	452.49	11.32	Very Light
Handling	95.31	97.55	6.23	7.45	619.69	14.15	Light
Post work	88.31	90.33	4.45	5.03	451.70	11.38	Very Light

Comparison of the values in the Table 6.9 and Table 6.10 indicates a reduction of heart rate and energy expenditure with the use of the automated system. These features were utilised as indicators of stress level.

In the Student t-tests of significant difference between the manual and automated systems conducted for heart rate, energy expenditure, total cardiac cost of work, physiological cost of work, the differences in the results were highly significant ( $P < 0.0001$ ) which indicates that automated RFID system resulted in highly significant improvements in these parameters.

Table 6.11 contains a summary of the findings of the extent to which automation and



RFID reduces average heart rate, energy expenditure and cost of work. These factors determine the extent of stress and fatigue on the operator. It also includes a significance testing and work physiology analysis of the two systems.

Figure 13.1 to Figure 13.5 in Appendix E contains raw output extracts from Graph Pad InStat software of the tests that were conducted to assess the significance of the probability that the results obtained were by coincidence

Table 6.11 Work physiology analysis between manual and automated systems

<b>Operation Procedure</b>	<b>Heart Rate (Beats/minute)</b>	<b>Energy Expenditure (kJ/minute)</b>	<b>Average TCCW</b>	<b>Average PCW</b>	<b>Workload Classification</b>
Manual	115.34	9.38	753.55	18.34	Moderately heavy
RFID	95.31	6.23	619.69	14.15	Light
Reduction	20.03*	3.15*	133.86*	4.19*	
Reduction (%)	17.3	33.5	17.8	22.8	

\*  $P < 0.0001$  (two-tailed Students t-test)

### 6.7.3 Stress Levels Analysis

Having considered the operator's environment, there was also a need for evaluating the impact of the handling system on cattle stress levels. As discussed earlier in Sections 6.3 and 6.4 above, breathing frequency and heart rate can be utilised as an indication of stress level.

Table 6.12 contains a comparison between results obtained from the evaluation process of breathing frequency for the two systems. The results obtained were compared to the postulated safe non-stress working breathing frequency obtained from equations presented by Mortola and Lanthier (2004).

Table 6.12 Estimated and Day 10 stress levels in cattle for the two systems

<b>Handling Mode</b>	<b>Average Cattle Mass (kg)</b>	<b>Safe Non-stress Breathing Frequency (bpm)</b> [ $f = 53W^{-0.251}$ ]	<b>Average Measured Breathing Frequency (bpm)</b>	<b>Stress Level Indicator (%)</b>
Manual	485.6	11.22	12.94	15.15
RFID	485.6	11.22	11.40	1.6
Two-tailed P value	P < 0.0001			
Confidence interval	$M_{\text{manual}} - M_{\text{auto}} = 1.540$ , 95% CI which is 1.274 to 1.806			
Intermediate values	t= 13.099, df = 9, correlation coefficient (r) = 0.9773			
Statistical significance	By conventional criteria, this difference is considered to be extremely statistically significant. Refer Figure 13.5 for more details			
Differences in stress level between the manual and automated systems as a percentage above non-stress threshold				13.55%

Figure 13.6 in Appendix E contains raw output extracts from Graph Pad InStat software of the tests that were conducted to assess the significance of the probability that the stress level results obtained were by coincidence

According to Grandin (2010) an animal is considered as being handled safely under non-stress conditions if its heart rate is on average 82.5 breaths per minute. Table 6.13 contains the results of the cattle heart rate measurements.

Table 6.13 Estimated and Day 10 stress levels from heart rate monitoring

<b>Procedure</b>	<b>Threshold Non-stress Heart Rate (Grandin, 2010)</b>	<b>Average Measured Frequency bpm</b>	<b>Stress Level Indicator %</b>
Manual	82.5	94.91	15.03
RFID	82.5	83.82	1.32
Two-tailed P value	P < 0.0001		
Confidence interval	$M_{\text{manual}} - M_{\text{auto}} = 11.080$ , 95% CI which is 9.082 to 13.078		
Intermediate values	t= 12.542, df = 9, correlation coefficient (r) = 0.9760		
Statistical significance	By conventional criteria, this difference is considered to be extremely statistically significant. Refer Figure 13.6 for details		
Stress Level Variation between Manual and Automated system as a percentage above non-stress threshold as per Grandin (2010)'s research findings of an average of 82.5 beats per minute			13.71%

Figure 13.7 in Appendix E contains raw output extracts from Graph Pad InStat software of the tests that were conducted to assess the significance of the probability that the heart rate results obtained were by coincidence.

The results from the evaluation indicate that the introduction of RFID and automation reduced animal stress level by an average 13.7%. Introducing RFID components into the system translated to a capital cost difference of infrastructure by R 98 500 (Flow control automation, electronic components and pneumatic devices) when compared to the basic manual facility. In addition to the manual labourers required for the operation, three technical personnel were required for the automated operations whilst a single technical person was sufficient for manual based handling. The technical efficiencies (TE) of the automated RFID and manual based systems were computed using Equation 6.8, and found to be 0.85 and 0.54 respectively.

#### 6.7.4 Summary of Results

Table 6.14, Figure 6.7, Figure 6.8 and Figure 6.9 all contain summarised results of the system evaluation. The results include capital requirements, technical expertise, total cardiac cost of work and technical efficiencies of the two systems.

Table 6.14 Summary of results of the system evaluation process

<b>Parameter</b>	<b>Handling Duration / Animal</b>	<b>Incorrect sorting %</b>	<b>Man Hour/ 30 cattle</b>	<b>Operator Stress Indicator PCW</b>	<b>Cattle Stress Indicator %</b>	<b>Energy Expenditure (kJ/minute)</b>	<b>TCCW</b>
Manual	32.1 s	8.0	1.7h	18.3	15.2	9.38	753.55
RFID	11.8 s	2.1	0.5h	14.2	1.6	6.23	619.69
Reduction %	63.2%	5.9%	69.7%	22.9%	13.6	33.58	17.76
P-value	<0.0001	<0.0001	<0.0001	<0.0001	<0.0001	<0.0001	<0.0001
t-value	24.3534	7.7460	45.1690	23.4290	13.0990	19.7930	23.3990
Correlation coefficient (r)	0.981	0.671	0.839	1.000	0.977	0.953	1.000

The basic alley lead passageway, handler access gates, flow control, weighing and sorting system components required a capital investment cost of R 101 500. Making

use of RFID supporting components for the flow control automation, electronic and pneumatic devices resulted in an increased capital cost difference of infrastructure by R 98 500. The capital requirements difference is illustrated in Figure 6.7. Figure 6.8 and Figure 6.9 contains graphical representation of the TCCW and TE contained in Table 6.14.

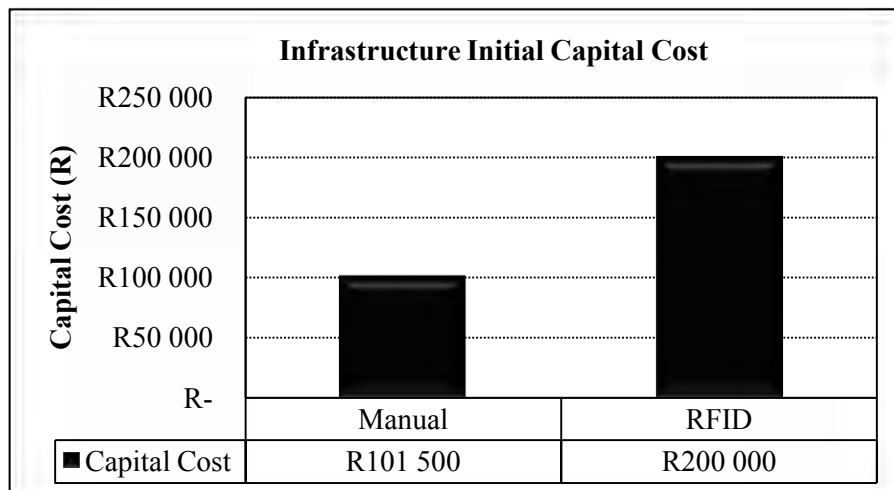

Figure 6.7 Initial input capital requirement for each system

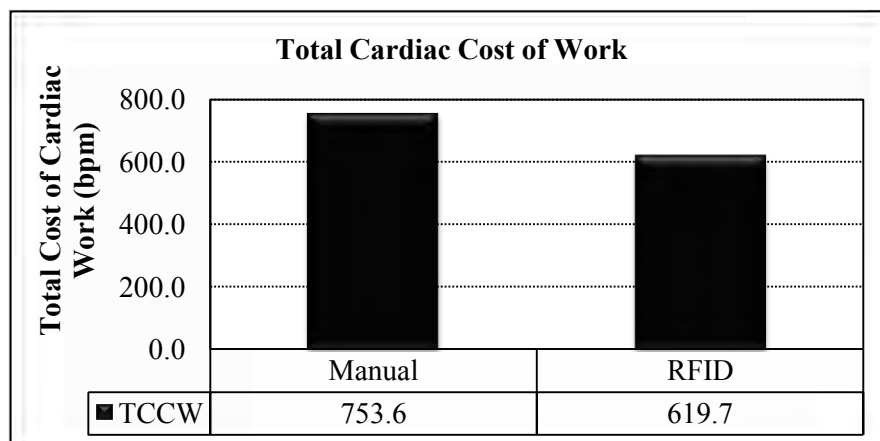

Figure 6.8 Total cost of cardiac work for the systems

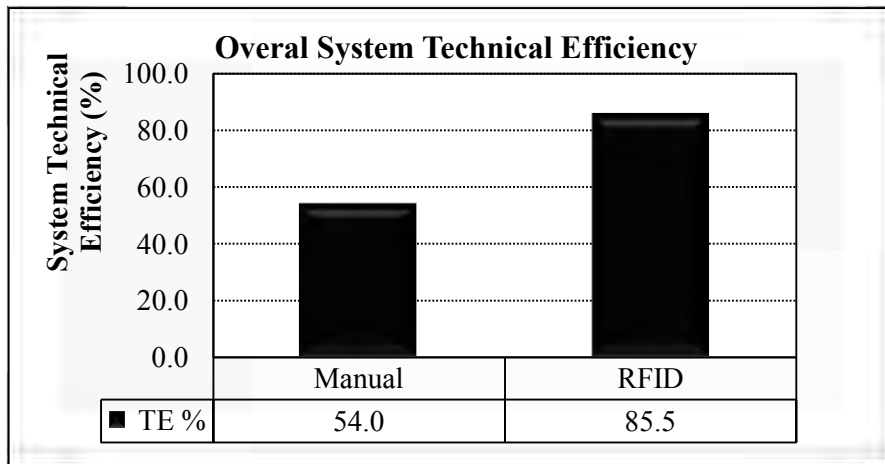

Figure 6.9 Overall technical efficiencies of the systems

### 6.8 Cost-Benefit Analysis for RFID Based Technology Introduction

The results in Section 6.7 strongly support the hypothesis that the introduction of RFID based technology in the cattle handling system translates into an improved system technical efficiency. However, it is also important to assess the impact on business profitability as consequence of the adoption of the automated system.

One of the key items in any business case is an analysis of the costs of a project and the payback period. In this case there is a need to compare the cost-benefits associated with the two systems. In doing this, certain assumptions were made. The assumption was made that sufficient land is available for the establishment of a comprehensive 500 cattle feedlot and its entire supporting infrastructure. Table 6.16 contains a comparative summary of the two systems with regards to input costs and calculated expected outputs.

It is evident that there is not a large difference in capital input required as both systems require the same infrastructure with the exception of areas where the RFID and associated support equipment needs to be installed. In addition, more training costs are required for the implementation of the RFID based system. The introduction of RFID technology has been shown to reduce man hours, handling duration and incorrect sorting, thus a reduced operational cost of approximately R 1 000 000 per annum is

allocated to the RFID based system compared to the manual system.

The significant benefits of the RFID based system are realised in the improved system performance, with reduced animal handling time and reduced animal stress resulting in greater gains in body mass per day as compared to the manual system. This translates to higher prices at the market and increased income for the RFID based system compared to the manual system. The net impact is that the introduction of RFID based technology results in an improved profitability of 15%, as shown in Table 6.15. Table 6.15 contains a list of assumptions made and consideration given when developing the cost benefit analysis

Table 6.15 Considerations given in feedlot operations (Grandin, 2003)

<b>Item</b>	<b>Description and consideration</b>
Weaner weight at feedlot entry	250 kg
Marketing weight	500 kg
Feedlot duration	150 days
Weight gain	250 kg
Average selling price of live weight	R45- 60/kg of live weight for meat sales and after value addition
Average feed consumed through cycle per animal	1500 kg per animal

Table 6.16 Cost benefit analysis between RFID and manual based support systems

Item	Classification	Details	RFID Based System (R)	Manual Based System (R)
System Costs	Capital Input for Implementation	Lead alleyways, restraining system, handler access gates, , feedlot pens, carcass disposal trench, manure lagoons, administration building, water supply system, fencing, security, silage bunkers, feed storage and processing unit, site earthworks and internal road networks and 500 herd of weaners to start off project.	R 7 100 000	R 7 100 000
		Specialised equipment requirements for the automated flow control gates, weigh-ID system, sorting system and their supporting infrastructures	R 400 000	-
	Recurring Costs	Annual system maintenance	R 105 000	R 40 000
		External consultants (Annual)	R 165 000	R 85 000
		Operational costs (Man hours/annual)	R 450 000	R 1 500 000
		Livestock feed and processed mixes: 750 tonnes/annum and water supply 6250 m <sup>3</sup> /anum	R 1 200 000	R 1 400 000
		Overheads (annual)	R 180 000	R 80 000
	Non Recurring Costs	Installation - additional	R 200 000	R 65 000
		Training		
	<b>Total System Costs (Annually)</b>			<b>R 9 800 000</b>
System Benefits	Income obtained from sales based on meat quantity and quality	Improvements for RFID system result from reduced man hours, reduced handling duration and incorrect sorting and reworking	R 4 500 000	R 3 802 000
<b>Total System Benefits (Annually)</b>			<b>R 4 500 000</b>	<b>R 3 802 000</b>

Table 6.17 contains the cash flows required to determine the payback period for the two systems. The comparison of the two system showed that RFID based system is a more viable option with a payback period of 3.5 years compared to the manually based system payback period of 10.5 years.

Table 6.17 Payback period comparison table

Year	Manual Based Handling (R)		RFID Based Handling (R)	
	Cash flow	Cumulative cash flow	Cash flow	Cumulative cash flow
0	(7 165 000)	(7 165 000)	(7 700 000)	(7 700 000)
1	697 000	(6 468 000)	2 400 000	(5 300 000)
2	697 000	(5 771 000)	2 400 000	(2 900 000)
3	697 000	(5 074 000)	2 400 000	(500 000)
4	697 000	(4 377 000)	2 400 000	<b>1 900 000</b>
5	697 000	(3 680 000)	2 400 000	4 300 000
6	697 000	(2 983 000)	2 400 000	
7	697 000	(2 286 000)	2 400 000	
8	697 000	(1 589 000)	2 400 000	
9	697 000	(892 000)	2 400 000	
10	697 000	(195 000)	2 400 000	
11	697 000	<b>502 000</b>	2 400 000	

In the cost benefit analysis undertaken for both systems the assumption was made that the cash flow pattern remains constant for both systems over the evaluation period. Business profitability is obtained by the margin between total system cost and total system benefits. Comparing the two systems margins will indicate the percentage of business profitability. The results contained in Table 6.17 show that the introduction of the RFID based technology as an alternative to a manual based system results in an increase in business profitability by 20% and shorten the payback period by 5 years. .



## 7. DISCUSSION AND CONCLUSIONS

Commercial feedlots in the South African beef industry account for up to 80 % of the meat produced in the country. The literature review contained in this document revealed that 95 % of conventional feedlot systems in South Africa utilise manual operations and this results in inefficient management practices. The challenges in such systems were found to include high operational costs, intensive labour requirements, inaccurate process control and increased stress and fatigue levels to both the animals and system operators.

From literature review and the evaluation conducted for 30 cattle with 8 men for the manual and 5 men for the RFID based systems, it was estimated that a total of 30 men are required to manually handle 500 cattle per day in feedlot setup with a monthly operational cost of R45000 as explained in Chapter 2 of the literature review. In a manual system the weigh-sort procedure yielded high durations of up to 59 seconds per animal with an average of 6 % incorrect reading. Recordings of heart rates as high as 108 bpm and 125 bpm for animal and operator respectively, were recorded for a manually operated system. These are an indication of high stress levels associated with the manual management in South African feedlots. These aspects have adverse effects on productivity and profitability of the enterprise. From the results obtained for the manual handling system it can be concluded that shortcomings of conventional manual management systems such as long animal handling duration, handling errors, limited consideration of animal welfare and poor sorting systems when selecting animals for marketing, contribute to low profitability. In order to find solutions to the challenges currently being experienced in beef facilities, a literature review of best management practices used internationally was undertaken in order to identify practices which could be adopted in South Africa to improve the management of cattle in feedlots and hence to improve system efficiencies.

From the literature reviewed it was evident that the introduction of automated RFID systems in some instances lowered handling durations by up to 45 seconds whilst also

reducing incorrect sorting to 0.1%. In some instances, only 10 men were required to process 500 cattle through the management system. This translated to a 50% reduction in the cost of system operation whilst also lowering stress and fatigue levels in both cattle and operator by 18% and 15% respectively. It was thus concluded that the introduction of RFID technology in a cattle management system could result in system improvements in the South African industry.

The aim of this study was to design, develop and assess the performance of an animal handling system that incorporates Radio Frequency Identification System (RFID) and automation in order to improve the cattle handling systems technology to facilitate improved operation and management. The technological development process followed through the normal design processes, which were: needs assessment, planning, design, consultation, procurement, fabrication, construction, re-design, final fabrication and evaluation. The funder of the project was consulted to establish other special requirements that had to be met. Problem areas were identified as the boxed shaped crush, ID-weighing and sorting systems. Conceptual design was developed following the three guides: funders' requirements, standardisation and technical requirements. Virtual tools were utilised to aid technical computations and designs throughout the development process. A number of modifications were made throughout the design process which included, portability, layout changes to enable tagging before handling, pneumatic rams guiding system for alignment, modification for free-standing components, modification for the ID-Weigh system to accommodate different animal sizes, and modification for the minimisation of external interference. The design modifications were incorporated into the final fabrication.

The system comprising of six components, a lead passage alleyway, restraining system, handler access gates, flow control double split gate, ID-weigh box and an automated sorting system and was evaluated in terms of performance and compared to the performance of a conventional management system. The system facilitates the flow of cattle from the receiving pens through the handling facility until they are sorted to the appropriate holding pens. The structural components that constitute the prototype animal handling system are a neck and body clamp with through access, a double-split

flow control gate, an identification and weigh box and a sorting system. An automation system that incorporates the RFID technology was installed in the components of the design prototype in conjunction with a manual by-pass. This was done in order to compare the functionality of the automated system and the conventional manual handling system. Thirty *Bonsmara* cattle were used when evaluating both the manual and automated RFID animal handling systems. The key parameters considered during the evaluation process were handling duration, stress level and fatigue for both the animal and operator, sorting accuracy, man hours of operation and overall technical efficiency of the system.

In order to establish the handling duration, cattle were timed while passing through the handling system. It was found that the automated system resulted in a 63 % reduction in the average handling duration compared to the manual system. An analysis of the variation in results of the total handling duration confirms the results established by other studies that, in cattle, it takes between 5-8 days for them to get used to new handling procedures. This was indicated by the stability of the total handling duration at 11.8 seconds per animal for the automated system from Day 6 to Day 10 of the evaluation process. Results of this evaluation process might not be a good indication of the performance parameters with wild cattle as the animals utilised for this procedure had been exposed to handling before and also that *Bonsmara* cattle are considered to be a docile and highly adaptive breed of cattle.

Through the use of the Polar Sport Tester-Profi and flank analysis measurement, the heart rate and breathing frequency of the operator and cattle were monitored. After the introduction of automation, the stress and fatigue were reduced by 23 % and 14 % on both handler and animal respectively. A comparison between the developed system in this study to other systems developed and evaluated at the University of Nebraska was undertaken. Results gave an indication of reduced stress levels in the developed system which is expected to result in improved meat quality. Analysis of incorrect sorting of animals for the two systems revealed that the introduction of RFID and automation increased the sorting accuracy by 5.5 %. This is consistent with results in other studies where, for example, Artman (1999) concluded that the use of RFID tags reduced

incorrect readings from 6 % to 0.1 %.

An analysis of the handling durations and labour requirements indicated that incorporating automation reduces man hours by 70 % which impacts on operational cost. The operational cost reduction from the reduced manpower requirement confirms experimental findings by Dairymasters (2009) from trial runs that were conducted on a dairy farm in Dublin, Ireland. The existing infrastructure was designed for 500 animals per day capacity operated by five handlers at a capital investment of R 200 000 and an operational cost of R25 000 per month. Automating the conventional system raises the initial capital requirement by R98 000. These aspects play critical roles in technology adoption due to higher initial capital requirement, shortage of a technically skilled labour force and cost implication associated with adoption. Using a two-tailed Student t-test for significance resulted in a statistically significant ( $P < 0.0001$ ) difference in all performance related variables between the manual and automated RFID systems. This is an indication that the probabilities of the improvements established in the system were not merely by coincidence. The P-value obtained in this study indicates that the introduction of RFID technology improved system performance. A cost benefit analysis was undertaken for both systems with the aim of assessing and determining the financially most viable system. An assumption was made that the cash flow pattern remains uniform for the two systems over the entire evaluation period. This analysis showed that the introduction of RFID based technology as an alternative to manual based system increased business profitability by 20 % and shortened the payback period by 5 years.

Although researchers encourage that systems be investigated fully over a period of 3 to 4 years to determine performance parameters under different environments, breeds and handlers, it was concluded that the introduction of RFID, electronics and automation improves the overall system technical efficiency by 32 % whilst enabling efficient selective handling. System technical efficiency is regarded as an indication of business profitability. Thus the automated RFID based system developed satisfies the hypothesis that the introduction of RFID based automated systems increases feedlot system profitability.

## 8. REFERENCES

- Aarts, H., Finkenzeller, T., Huiskes, J.H., Lambooij, E. and Langeveld, N. G. 1992. Electronic identification with injectable transponders in pig production: Results of a field trial on commercial farms and slaughterhouses concerning injectability and irretrievability. [Internet]. Institute for Animal Science and Health, Zeist, The Netherlands. Available from: <http://www.ncbi.nlm.nih.gov/pubmed/8751271> [Accessed 18/3/2009].
- Aderson, R. S. and Edney, ATB. 1991. *Practical Animal Handling*. Library of Congress Cataloging-in-Publication Data, Toronto, Canada.
- Anderson, R. V., Rasby, R. J., Klopfenstein, T. J., and Clark, R. T. 2005. An Evaluation of Production and Economics Efficiency of two Beef Systems from Calving to Slaughter. *Journal of Animal Science*, 83: 694-704.
- Allflex. 2010. Allflex Tags, EID Tags, Stick Reader, Compact Reader, Tagger. [Internet]. Allflex Homepage. Available from: <http://www.rfidtagstcc.com/site/1615593/page/877073>. [Accessed 20/03/2010].
- Apple, K., Huhnke, R.L. and Harp, S. 1994. *Modern Corral Design*. Report Number E-938, Oklahoma State University, Stillwater, Oklahoma, USA.
- Artman, R., 1999. Electronic identification systems: state of the art and their further development. *Computers and Electronics in Agriculture* 24(1-2, November): 5-26.
- ATL. 2010. Cattle Systems Technology. [Internet]. Agricultural Technology. London, UK. Available from: <http://www.agricultural-technology.co.uk>. [Accessed 10/05/2010].
- Borg, R. 1993. *Corrals for Handling Beef Cattle*. Alberta Agriculture, Food and Rural Development, Edmonton, Alberta, USA.
- Boontech. 2010. Automated Livestock Systems. [Internet]. Boontech Pty Ltd Homepage. Kyneton, Victoria, Australia. Available from: <http://www.boontech.com/> [Accessed 09/05/2010].
- Bowling, M. B., Pendell, D. L., Morris, D. L., Yoon, Y., Katoh, K., Belk, K. E., and Smith G. C. 2008. Review: Identification and Traceability of Cattle in Selected Countries Outside of North America. *The Professional Animal*

- Scientist*, 24(Aug): 287-294.
- Breedt, H.T., 2003. *Beef Cattle Facilities Manual*. Report Number ISDN1003/1, ARC-IAE, Silverton, RSA.
- Butchbaker, A.F., Harp, S., and Rider, A., 1999. Beef working. Sorting and loading facilities. ASAE Paper Number.74-4523. ASAE, St Joseph, Michigan, USA.
- Boote, G.L.N. and Mavundza, T. 2009. Design, construction and evaluation of an automated four way sheep sorter. Unpublished BSc Eng. Final Year Design Project, School of Bioresources Engineering and Environmental Hydrology, University of KwaZulu-Natal, Pietermaritzburg, RSA.
- Bowling, M. B., Pendell, D. L., Morris, D. L., Yoon, Y., Katoh, K., Belk, K. E. and Smith, G. C. 2008. Review: Identification and Traceability of Cattle in Selected Countries Outside of North America. *Professional Animal Scientist*, 24: 287-294.
- Challis, C. 2010. Personal communication, Axxon Pty, Johannesburg, South Africa 26/10/2010.
- Challis, C. 2011. Personal communication. Axxon Pty, Johannesburg, South Africa 03/03/2011.
- CCA. 2010. The South African feedlot industry to grow. STATS SA. Animal Statistics Department, Census of Commercial Agriculture, Pretoria, RSA.
- Chipa, M.J., Siebrits, F.K., Ratsaka, M.M., Leeuw, K.J., and Nkosi, B.D. 2010. Growth Performance of Feedlot Weaners Cattle Fed Diet Containing Different Levels of Cold Press Soya Bean Oilcake. In: *Proceedings of the 43rd Congress of the South African Society for Animal Science, Pretoria, South Africa*, 499-501. South African Journal of Animal Science, Pretoria, RSA.
- CIGR, 1984. *Report of Working Group on Climatization of Animal Houses*. CIGR, Liège, Belgium.
- CIGR, 1992. *2nd Report of Working Group on Climatization of Animal Houses*, 1989, 2nd Edition. CIGR, Liège, Belgium.
- CIGR 1994. *The Design of Dairy Cow Housing*. Report of CIGR Section 2 Working Group No.14. ADAS Bridgets Dairy Research Centre Farm Buildings Research Team, CIGR, Liège, Belgium.
- Collyer, J. and Viljoen, J., 2003. Feedlot options for small scale farmers. [Internet]. KwaZulu- Natal Department of Agriculture, Research and Extension Engineers,

- Pietermaritzburg, RSA. Available from:  
[http://agriculture.kzntl.gov.za/portal/AgricPublications/TechnicalInformation/Fee  
dlotOptionsforSmallScaleFarmers/tabid/221/Default.aspx](http://agriculture.kzntl.gov.za/portal/AgricPublications/TechnicalInformation/Fee%20OptionsforSmallScaleFarmers/tabid/221/Default.aspx). [Accessed  
26/8/2009].
- Cordova and Wallace, J. D. 1978. Forage intake by grazing livestock: a review. *Journal of Range Management*, 31(6): 430-438.
- Cox, S., Mathis, C., Petersen, M., and Rubio, M. 2006. *Using ear tags to complement individual animal record keeping*. Report number 2061/06/06, NMSU, New Mexico, USA.
- Dairymasters. 2009. RFID on Dairy Farms. Internal Report ISDM101/3, [Internet]. Dairymaster's Inc, Dublin, Ireland. Available from: <http://www.rfid4sme.com/dairymasters.pps>. [Accessed 28/09/2009].
- Dean, M., Leigh, W., Murray, D., and Roberts, R., 1992. Basis of RFID research on tags. Department of Range Management, Paper No. 3. Allen Press, Utah, USA.
- Eigenberg, R. A. and Brown-Brandl, T. M. 2005. Development of a cattle ID monitoring system. 2005. In: *Proceedings of the Seventh International Livestock Environment Symposium*, 600-606. ASABE, St. Joseph, Michigan, USA.
- Eradus, T., Jansen, F., and Klindtworth, J., 1999. Animal identification and monitoring. *Computers and Electronics in Agriculture*. 24(1-2), November 1999: 91-98.
- Erickson, G. E. 2010. Beef Cattle: Intensive Management. *Encyclopaedia of Animal Science*, 1(1): 25-28.
- Ewbank, R. and Parker, J. 2007. The behaviour of cattle in crushes. *Veterinary Record*, 73: 853-856.
- Fallon, R.J., Rogers, P.A.M. Earley, B. 1991. *Electronic Animal Identification-End of Project.*, Report No.ARMIS604/91, Grange Research Centre, Dublin, Ireland.
- Fatcow. 2010. Australia's Local Farming and Agricultural Director. [Internet]. Fatcow Directory Homepage. Victoria, Australia. Available from: <http://www.fatcow.com.au/> [Accessed 10/05/2010].
- Festo. 2010. Automation and Control Systems. [Internet]. Festo Products Homepage. Techno Park, Pretoria, RSA. Available from: [http://www.festo.com/cms/en-za\\_za/index.htm](http://www.festo.com/cms/en-za_za/index.htm) [Accessed 15/10/2010].
- Fleming, E., Fleming, P., Griffith, G., and Johnston, D. 2010. *Measuring Beef Cattle*

- Efficiency in Australian Feedlots: Applying Technical Efficiency and Productivity Analysis Method.* Australasian Agribusiness Review. ISSN 1442-6951: 18-201(4).
- Fulwider W., Grandin, T., Rollin E., Engle E., Dalstead L., and Lamm D., 2008. Survey of dairy management practices on one hundred thirteen North Central and North Eastern United State Dairies. *Journal of Dairy Sciences* 91:1686-1692.
- Ford, D. 2010. Personal communication. South African Feedlot Association, Pretoria, RSA, 27 November 2008.
- Galyean, M. L., DiLorenzo, N., McMeniman, J. P., Defoor, P. J. 2010. Predictability of feedlot cattle growth performance. *Journal of Animal Science*, 1(1): 332-333
- Geers, F., 1997. Genesis of the Cooperative Research Centre for the Cattle and Beef Industry: integration of resources for beef quality research (1993–2000). [Internet]. Collingwood reports, Victoria, Australia. Available from: <http://www.publish.csiro.au/journals/ajea> [Accessed 15/02/2009].
- Government Gazette No. R. 10154. 2010. Government Gazette - Republic of South Africa. No. R. 10154.
- Grandin, T. 1980(a). Observations of cattle behaviour applied to the design of cattle handling facilities. *Applied Animal Ethology*, 6(May): 19-31.
- Grandin, T. 1980(b). Livestock behaviour as related to handling facilities design. *International Journal for the Study of Animal Problems*, 1(Jan): 33-52.
- Grandin, T. 1984. Race system for cattle slaughter plants with 1.5m radius curves. *Applied Animal Behaviour Science*, 13: 295-299.
- Grandin, T., 1989. Behavioural Principles of Livestock Handling [Internet]. Professional Animal Scientist, Colorado, USA. Available from: <http://www.grandin.com/references/new.corral.html> [Accessed 15/02/2010].
- Grandin, T., 1990. Design of loading facilities and holding pens. *Applied Animal Behaviour Science*, 28: 187-201.
- Grandin, T., 1993. Behavioural agitation during handling of cattle is persistent over time. *Applied Animal Behaviour Science*, 36: 1-9.
- Grandin, T., 1994. Solving livestock handling problems. *Veterinary Medicine*, 10: 989-998.
- Grandin, T., 1997. The design and construction of facilities for handling cattle.



- Livestock Production Science*, 49: 103-119.
- Grandin, T., 1998. Cattle Handling Systems. Practical tips on why some handling systems work better than others. *Practical Beef tips*, 98(September): 50-52.
- Grandin, T., 1999. Safe handling of large animals (cattle and horses). *Philadelphia Occupational Medicine*, 14: 195-212.
- Grandin, T., 2000(a). Behavioural principles of handling cattle and other grazing animals under extensive conditions. In: eds. Grandin, T, *Livestock Handling and Transport (2nd edition)*, 63-86. CABI Publishing, Oxon, UK.
- Grandin, T. 2000(b). Handling facilities and restraint of range cattle. In: eds. Grandin, T, *Livestock Handling and Transport (2nd edition)*, 103-125. CABI Publishing, Oxon, UK.
- Grandin, T. 2003. Handling facilities and restraint of range animals. *Livestock Production Science* 85(2003): 85-101.
- Grandin, T. 2004. Solving livestock handling problems. *Veterinary Medicine* 26(2004): 989-998.
- Grandin, T., 2010. Loading chute and Catwalk Cross Section [Internet]. Professional Animal Scientist, Colorado, USA. Available from: <http://grandin.com/design/blueprint/ramp2.html>. [Accessed 20/03/2010].
- Hanton, P. Hasker, P. J. S. Konerman, J. and Lambooi, E. 1992. Evaluation of electronic identification transponders implanted in the rumen of cattle. *Australian Journal of Experimental Agriculture* 36(1): 19 – 22.
- Hardy, R. and Meadowcroft, S. 1990. Indoor Beef Production. In: *Cattle Production Handbook*, Farming Press, Ipswich, UK.
- Hasker, P.J.S., Bassingthwaite, J., Round, P.J. 1992. A comparison of sites for implanting identification transponders in cattle. *Australian Veterinary Journal* 69(4): 91 - 91.
- HDGASA. 2010. Hot Dip Galvanizers Association of Southern Africa [Internet]. HDGASA Website St Andrews, Bedfordview, Johannesburg, RSA. Available from: <http://www.hdgasa.org.za/infoSheets.html> [Accessed 20/07/2010].
- Holmes, R.J. 1991. Cattle. In: eds. Anderson, R.S. and Edney, A.T.B, *Practical Animal Handling*, 63-86. Pergamon Press, Oxford, UK.
- Hossain, M. A. and Quaddus, M. 2010. An Adoption Diffusion Model of RFID-Based

- Livestock Management System in Australia. In: *Human Benefit through the Diffusion of Information Systems Design Science Research*. IFIP Advances in Information and Communication Technology, 179-191. Springer Publishing Co., Boston, USA
- IDEA, 2003. *Technical guidelines for Council Regulation: In field application of identifiers, their reading and recognition*. Report No.21/2004. Institute for the Protection and the Security of the Citizen. European Commission, Italy.
- INRA. 2009. Automatic sorting of sheep using RFID. Internal Report INRA151, pp 28. [Internet]: Available from: [http://www.inra.fr/partnerships/privatesector/livefromlabs/\\_automatic-sorting-system-of-sheep-using-RFID.html](http://www.inra.fr/partnerships/privatesector/livefromlabs/_automatic-sorting-system-of-sheep-using-RFID.html) [Accessed 16/08/2009].
- ISO Standards, 1999a. 1461. Hot dip galvanized coatings on fabricated iron and steel articles - Specifications and test methods. International Organization for Standardization (ISO), Geneva, Switzerland.
- ISO Standards, 1999b. 14713. Protection against corrosion of iron and steel in structures - Zinc and aluminium coatings - Guidelines. International Organization for Standardization (ISO), Geneva, Switzerland.
- ISO Standards, 2010a. 11784. Radio Frequency Identification (RFID) for Animal – Code Structure Definitions-Guidelines. International Organization for Standardization (ISO), Geneva, Switzerland.
- ISO Standards, 2010b. 11785. Radio Frequency Identification (RFID) for Animal- Technicalities of the Tag and Reader for Compatibility-Guidelines. International Organization for Standardization (ISO), Geneva, Switzerland.
- Idea21. 2010. Virtual Reality and Prototyping [Internet]. Ideas21 Ltd. London EC1M 5UD, UK. Available from: [http://www.ideas21.co.uk/categories/20080217\\_12](http://www.ideas21.co.uk/categories/20080217_12) [Accessed 13/09/2010].
- Jandrow, J., Lovell, C. A. K., Materov, I., and Schmidt, P, .1982. On the estimation of inefficiency in the stochastic production function model. *Journal of Econometrics*, 25(Jan): 110-113.
- Janžekovič, M.; Muršec, B.; Janžekovič, I. 2005. Development of non-invasive method of measuring of heart rate in cattle. In: Proceedings of the 4th DAAAM International Conference on Advanced Technologies for Developing Countries,

- September 21-24, Croatia, ATDC'05, Slavonski Brod, Vienna: DAAAM International, pp. 523-528.
- Levitan, B., 2010. Cost Benefit Analysis [Internet]. Business Improvement Manager, Manchester Metropolitan University, Manchester, UK. Available from: <http://www.mmu.ac.uk/bit/docs/Cost-Benefit-analysis-toolkit-v2.pdf> [Accessed 12/01/2013].
- Lewis. 2010 The Premium Tag System for Superior Livestock Management. [Internet] Lewis Cattle Oiler Co Ltd. Oak Lake, Manitoba, Canada. Available from: <http://www.lewiscattleoilers.com/other.html#corral> [Accessed 10/05/2010].
- Ligthelm, A. A. and van Wyk L. A. 1985. The policy implications of an appropriate development strategy for Southern Africa. *Development Southern Africa*, 2: 324-345
- Ilie-Zudor, E., Kemeny, Z., van Blommestein, F., Monostori, L. and van der Meulen, A. 2010. A survey of applications and requirements of unique identification systems and RFID techniques. *Computers in Industry*, 62(3): 227-252
- Lambooij, E. and Merks, J 1989. Automatic electronic identification systems for farm animals. In: Lambooij, E, *Automatic electronic identification systems for farm animals*. 17-19. Brussels, Belgium.
- Longhorn. 2010. Livestock Handling Systems. [Internet].Thompson Longhorn Livestock Equipment Homepage. Goomburra Valley, QLD 4362, Australia. Available from: <http://www.thompsonlonghorn.com.au/index.asp> [Accessed 10/05/2010].
- Louw, A., Grosskoff, J. F. W. and Groenewald, J. A. 2003. Beef Production Systems and Sales Strategies in an Extensive Ranching Region in South Africa. *Agricultural Systems Journal*, 4(2): 101-104.
- Mapiye, C., Chimonyo, M., Muchenje, V., Dzama, K., Munyaradzi, M., Marafu, C. and Raats, J.G., 2007. Potential for Value-addition of Nguni Cattle Products in the Communal Areas of South Africa: A review. *African Journal of Agriculture Research*. 2 (October), 488-495.
- Marshall, B.L. 1977. Bruising in cattle presented for slaughter. *New Zealand Veterinary Journal*, 25: 83-86.
- Maton, A. Daelemans, J, and Lambrecht, J. 1985. *Housing of Animals*. . Elsevier

- Science Publishing Company INC, New York, United States.
- Mavundza, T., 2010. Personal communication, UKZN, Pietermaritzburg, South Africa, 15/01/2010.
- McCauill, K. 2011. Personal communication. Tru-Test Pty Ltd, Auckland, New Zealand 04/03/2011.
- McDermott, J.J. Staal, S.J. Freeman, H.A. Herrero, M. and Van de Steeg, J.A. 2010. Sustaining Intensification of Smallholder Livestock Systems in the Tropics, *Livestock Science*, 130(1): 95-109.
- McNitt, J.I. 1983. *Livestock Husbandry Techniques*. Granada Publishing Limited, London, UK.
- Meuling, A. J., 2006. Livestock production systems and selection criteria. In: Lambooij, E, *State-of-the-art, Livestock environment 2*, 300-320. Food Engineering Association, Michigan, USA.
- Mortola, J. P, and Lanthier, C. 2004. *Breathing Frequency in Ruminants: A Comparative Analysis with non-ruminant Mammals*. Elsevier Science Publishing Company INC, New York, United States.
- Mukuahima, G., 2008. The performance of beef cattle bulls in the Vrede district of Mpumalanga, South Africa. Unpublished MSc Dissertation, School of Agricultural Sciences, University of Pretoria, South Africa.
- Murphy, R. G. L., Pendell, D. L., Morris, D. L., Scanga, J. A., Belk, K. E. and Smith, G. C. 2008. Review: Animal Identification Systems in North America. *Professional Animal Scientist*, 24: 277-286.
- Mutenje, T. J. 2009. The Application of Radio Frequency Identification for the Management of Beef Cattle. Unpublished MScEng Proposal Design Project, School of Bioresources Engineering and Environmental Hydrology, University of Natal, Pietermaritzburg, RSA.
- Mutenje, T. J. 2010(a). *Venda 500 Cattle Feedlot Design Report*. ARC-IAE, Silverton, RSA.
- Mutenje, T.J., 2010(b). *Agricultural Infrastructure design drawings*. Unpublished Standard Plans, ARC-IAE, Silverton, RSA.
- Naas, I., 2002. Application of Mechatronics to animal production. *Agricultural Engineering International: the CIGR Journal of Scientific Research and*

- Development*. Invited Overview Paper 4(2): 58-72.
- NDA , 2010. Abstract for Agricultural Statistics. Yearly Agricultural statistics. Vol 5 of 2010: October 2010, Pretoria, RSA.
- Nilsson, C. 1992: Walking and lying surfaces in livestock houses. In: ed. C. Phillips and D. Piggins, *Farm Animals and the Environment*. p. 93-110. CAB, UK.
- NMR. 2010. Livestock Feeding and Handling Equipment [Internet]. NMR Engineering Homepage. Newcastle, RSA. Available from: <http://www.nmreng.co.za/> [Accessed 12/06/2010].
- Notter, D. R., Sanders, J. O., Dickerson, G. E., Smith, G. M., Cartwright, T. C. 1979. Simulated Efficiency of Beef Production for a Midwestern Cow-Calf-Feedlot Management System. *Journal of Animal Science*, 49: 70-80.
- Nowers, C.B. and Welgemoed, J. 2010. The Economic Viability of Finishing Nguni Weaners on Natural Veld and Permanent. In: *Proceedings of the 43rd Congress of the South African Society for Animal Science, Pretoria, South Africa*, 422-423. *South African Journal of Animal Science*, Pretoria, RSA.
- Omron. 2010. Industrial Automation Systems. [Internet]. OMRON Electronics (Pty) Ltd (OEE-ZA). Longmeadow South, 1640 Modderfontein, RSA. Available from: <http://industrial.omron.co.za/> [Accessed 10/05/2010].
- Pendell, D.L., Brester, G.W., Schroeder, T. C., Dhuyvetter, K. C. and Tonsor, G. T. 2010 Animal Identification and Tracing in the United States. *American Journal of Agricultural Economics*, 92(4): 927-940.
- Racewell. 2010. Superior Stock Handling Solutions [Internet]. IRacewel Pty. Wespac, New Zealand . Available from: <http://www.racewell.co.nz/> [Accessed 20/05/2010].
- Ratsaka, M., 2009. *Cattle management in South Africa*. Report number ISDN4223/40, ARC-IRENE, Pretoria, RSA.
- RFID Journal. 2005, What is RFID? [Internet]. RFID Tribe, Boston, USA. Available URL: <http://www.rfidjournal.com/article/articleview/1339/1/129/>. [Accessed 18/3/2009].
- Rodahl, K. 1989. *The Physiology of Work*. Philadelphia: Taylor and Francis, Ltd. 240-241.
- Rudd. 2010. Identification and Cattle Handling Systems [Internet]. Rudd Products

- Homepage. Kyalami, Midrand, Pretoria, RSA. Available from: <http://www.rudd.co.za/index.html> [Accessed 10/09/2010].
- SABS Standards, 2010(a). 435. Steel Reverts and Fasteners. South African Bureau of Standards (SABS), Pretoria, South Africa.
- SABS Standards, 2010(b). 763-1997. Hot Dip Galvanised Coating. South African Bureau of Standards (SABS), Pretoria, South Africa.
- SABS Standards, 2010(c). 1200-H-1990. Structural Steel Works. South African Bureau of Standards (SABS), Pretoria, South Africa.
- SABS Standards, 2010(d). 1431. Metal Fabrication Standard. South African Bureau of Standards (SABS), Pretoria, South Africa.
- SABS Standards, 2010(e). 3575-1996. Continuous hot dip zinc coated carbon steel sheet of commercial, lock forming and drawing grades. South African Bureau of Standards (SABS), Pretoria, South Africa.
- SABS Standards, 2010(f). 4998-1996. Continuous Hot Dip Galvanised Coated Steel Sheets. South African Bureau of Standards (SABS), Pretoria, South Africa.
- Shackleton, C.M. 1993. Are the communal grazing lands in need of saving? *Development Southern Africa*, 10: 65-78.
- SACO. 2010. *Technical report on Cattle Management*. Report No. SAC10/2010. RenTech Technology. Pretoria. RSA.
- SAFA., 2010. South African Feedlots industry and the economics of beef production. Unpublished Research document. Research Department, South African Feedlot Association, Pretoria, RSA.
- Samad, A., Murdeshwar, P. and Hameed, Z. 2010. High-credibility RFID-based animal data recording system suitable for small-holding rural dairy farmers. *Computers and Electronics in Agriculture*, 73(2): 213-218.
- SANS Standards, 2010. 121. Hot dip Galvanising. South African Bureau of Standards (SABS), Pretoria, South Africa.
- Schleppe J. B., Lachapelle G., Booker C. W. and T. P. 2010. Challenges in the design of a GNSS ear tag for feedlot cattle. *Computers and Electronics in Agriculture*, 1: 84-95.
- Schoonover, C.W., Peterson, B.A., Vermillion, S.D., Maghirang, R.G. and Schrock, M.D. 2001. Development of an energy-absorbing headgate for cattle squeezes

- chutes. *Applied Engineering in Agriculture*, 17: 577-581.
- Smith, G. C., Pendell, D. L., Belk, K. E., Tatum, J. D., Sofos, J. N., and Morris, D. L. 2009. Opinions of Those in Cattle, Swine, and Sheep Slaughtering and Rendering Sectors Regarding Aspects of the National Animal Identification System. *Professional Animal Scientist*, 25: 641-653.
- Stefanowska, J., Smits, M. C. J., and Braam, C. R., 1998. *Impact of floor surface on behaviour, locomotion and foot lesions in cattle*. Report No. 98-09. 68. IMAG-DLO, Wageningen, the Netherlands.
- Strydom, P. E., Frylinck, L., van der Westhuizen, J., Burrow, H. M. 2008. Growth performance, feed efficiency and carcass and meat quality of tropically adapted breed types from different farming systems in South Africa. *Australian Journal of Experimental Agriculture* 48, 599–607.
- Subak, S. 1999. Global environmental costs of beef production. *Ecological Economics*, 30(1): 79-91.
- Talbot, G. 2011. Personal Communications. Taltec Cattle Systems, Brits, South Africa.
- Taltec. 2010. Livestock Handling Equipment [Internet]. Taltec Homepage. Britz, RSA. Available from: [http://www.taltec.co.za/products\\_Landing.aspx](http://www.taltec.co.za/products_Landing.aspx) [Accessed 12/06/2010].
- Taylor, I.A. 1997. Opportunity awaits livestock equipment manufacturers. Livestock Environment V. In: *Proceedings of the 5th International Symposium, Bloomington, Minnesota*, 252-253. American Society of Agricultural Engineers, Michigan, USA.
- Trovan., 2009. Livestock management: Argentina RFID identifiers with TROVAN Transponders for brucellosis eradication. [Internet]. Available from: <http://www.trovan.com/articles/livestock.htm>. [Accessed 05/05/2009].
- Varghese, M A, P N Saha and N Atreya. 1994. A rapid appraisal of occupational workload from a modified scale of perceived exertion. *Ergonomics*, 37(3): 485-491.
- Vink, N. 1987. An Institutional Approach to Livestock Development in Southern Africa. *Development Southern Africa Journal*, 4: 171-174.
- Vowles, W.J. 1982. Cattle handling facilities. *Proceedings of the Australian Society of Animal Production*, 14: 119-120.

- Vowles, W.J. and Hollier, T.J. 1982(a). The influence of yard design on the movement of animals. *Proceedings from the Australian Society of Animal Production*, 14: 597.
- Vowles, W.J. and Hollier, T.J. 1982(b). A survey of commercial cattle handling facilities on farms in Victoria. *Proceedings from the Australian Society of Animal Production*, 14: 598.
- Vowles, W.J., Eldridge, G.A. and Hollier, T.J. 1984(a). The behaviour and movement of cattle through forcing yards. *Proceedings of the Australian Society for Animal Production*.15: 766.
- Vowles, W.J., Eldridge, G.A. and Hollier, T.J. 1984(b). The behaviour and movement of cattle through single file handling races. *Proceedings of the Australian Society of Animal Production*, 15: 767.
- Voulodimos, A. S., Patrikakis, C. Z., Sideridis, A. B., Ntafis, Vasileios A. and Xylouri, E. M. 2010. A complete farm management system based on animal identification using RFID technology. *Computers and Electronics in Agriculture*, 70(2): 380-388.
- Walker, J., 2009. Radio Frequency Identification for Beef Cattle. [Internet]. South Dakota State University, Extension Area Beef Specialist, South Dakota, USA. Available from: <http://www.thebeefsite.com/articles/821/radio-frequency-identification-for-beef-cattle.htm> [Accessed 23/8/2009].
- Ward, G. 2011. Personal Communications. Pratley Systems, Auckland, New Zealand.
- Weeks, C.A., McNally, P.W. and Warriss, P.D. 2002. Influence of the design of facilities at auction markets and animal handling procedures on bruising in cattle. *Veterinary Record*, 150: 743-748.



## **9. APPENDIX A: COMPLETE HANDLING SYSTEM DESIGN NOTES**

The detail of the system design is provided separately on the attached CD for information. The contents are as detailed in Table 9.1.

Table 9.1 Contents of Appendix A: System design notes

<b>ITEM NO</b>	<b>DETAILED DESCRIPTION OF CONTENT</b>
<b>A1</b>	BOX SHAPED CATTLE CRUSH DESIGN NOTES
<b>A2</b>	CATTLE FLOW CONTROL SYSTEM DESIGN NOTES
<b>A3</b>	CATTLE SLIDING GATE SYSTEM DESIGN NOTES
<b>A4</b>	IDENTIFICATION AND WEIGH BOX DESIGN NOTES
<b>A5</b>	CATTLE RESTRAINING SYSTEM NOTES
<b>A6</b>	HANDLER ACCESS GATES DESIGN NOTES
<b>A7</b>	CATTLE SORTING SYSTEM DESIGN NOTES
<b>A8</b>	COMBINED SYSTEM PROTOTYPE DEVELOPMENT
<b>A9</b>	AUTOMATION AND PNEUMATIC SYSTEM DESIGN NOTES

## 10.APPENDIX B: DEVELOPED VIRTUAL DESIGN DRAWINGS

Appendix B contains detailed information provided separately for all components included in the design process. The contents are as detailed in **Error! Reference source not found.**

Table 10.1 Contents of Appendix B: Virtual prototype outputs

ITEM NO	DETAILED DESCRIPTION OF CONTENT
B1 Figure 10.1	BOX SHAPED CATTLE CRUSH PROTOTYPE 1. Detailed Design drawing
B2 Figure 10.2	CATTLE FLOW CONTROL SYSTEM PROTOTYPE 1. Detailed Design drawing
B3 Figure 10.3	CATTLE SLIDING GATE SYSTEM PROTOTYPE 1. Detailed Design drawing
B4 Figure 10.4	IDENTIFICATION AND WEIGH BOX PROTOTYPE 1. Detailed Design drawing
B5 Figure 10.5	HANDLER ACCESS GATES PROTOTYPE 1. Detailed Design drawing
B6 Figure 10.6	CATTLE SORTING SYSTEM PROTOTYPE 1. Detailed Design drawing

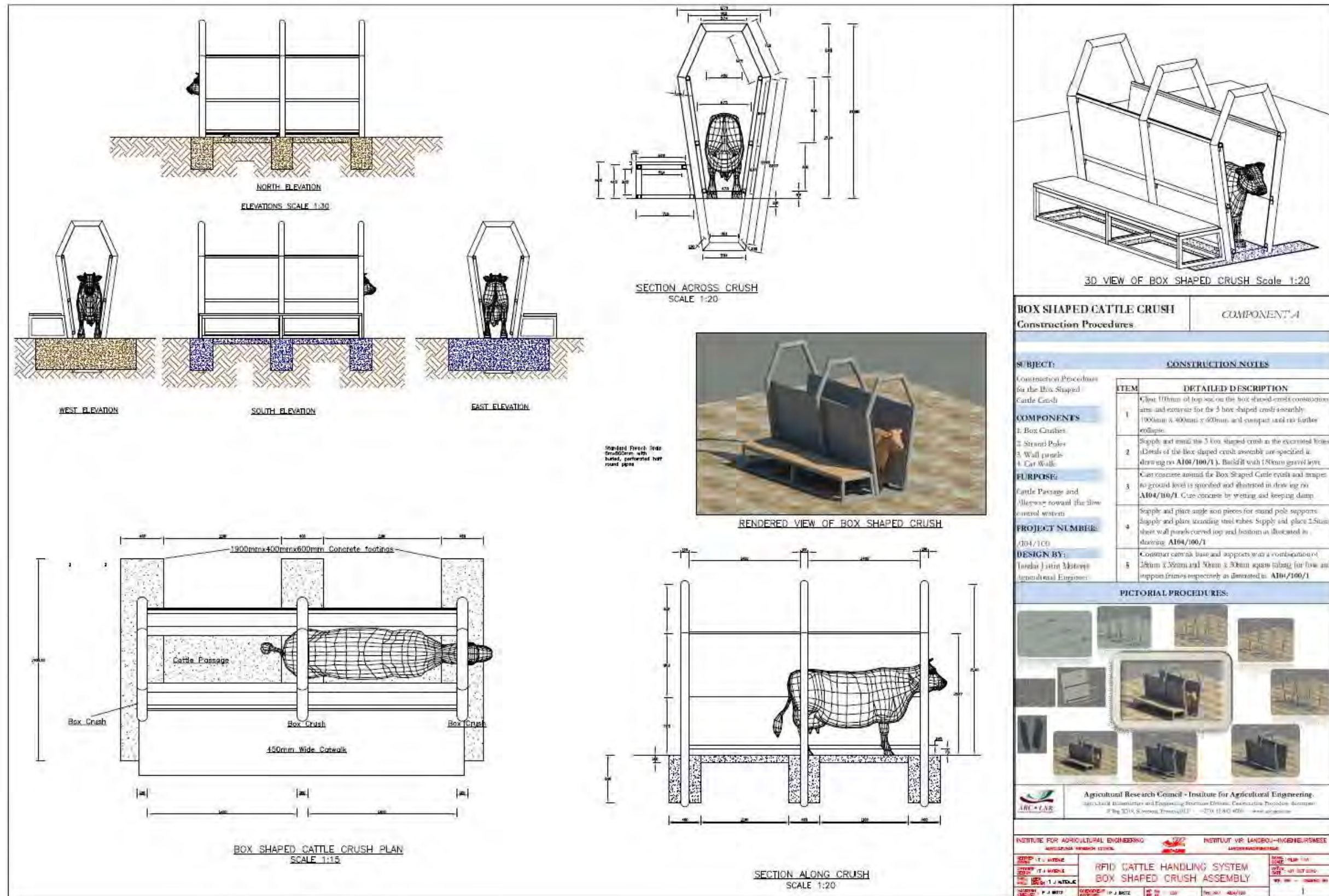
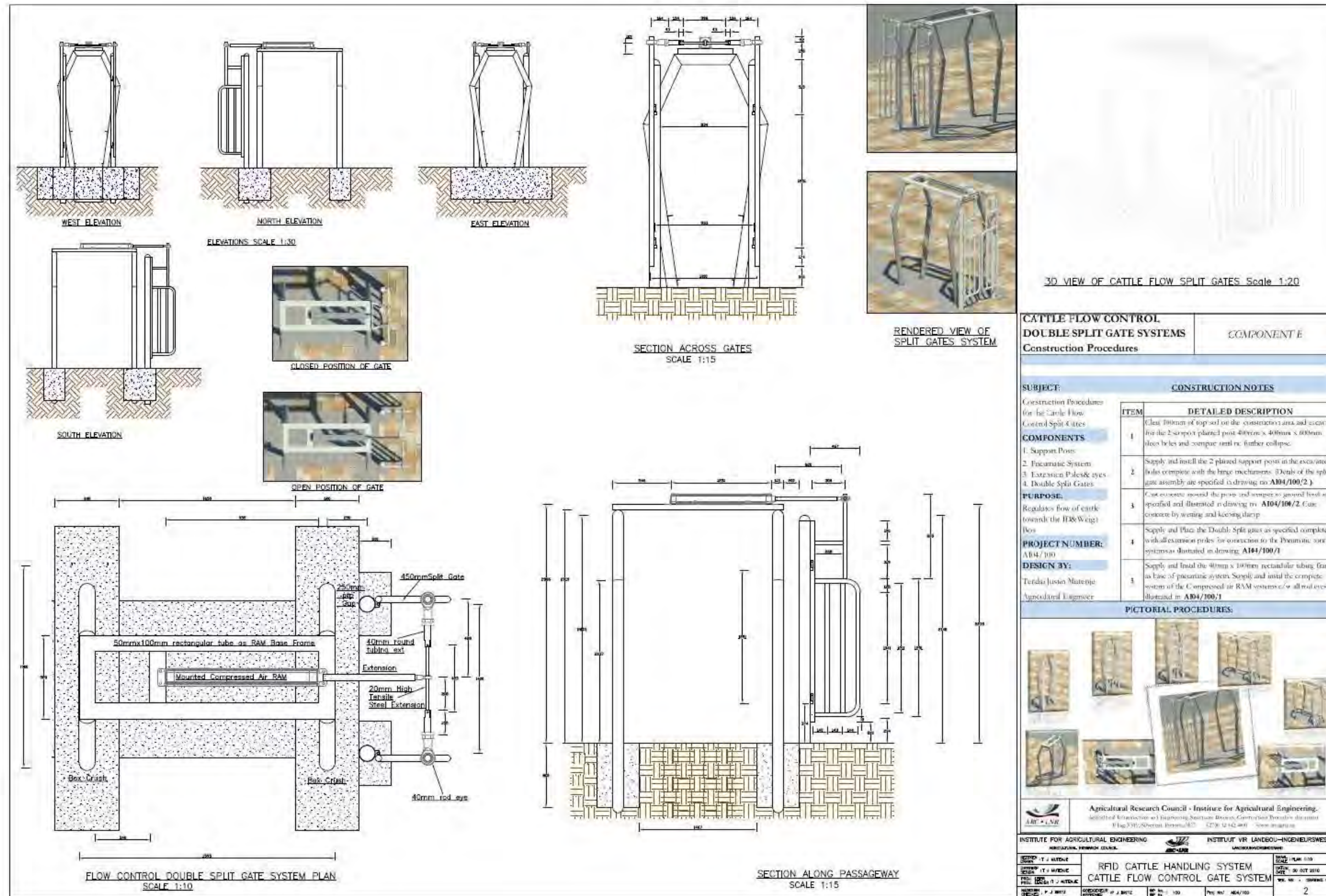

Figure 10.1 Box shaped crush detailed design drawing



**CATTLE FLOW CONTROL DOUBLE SPLIT GATE SYSTEMS**  
**Construction Procedures**

COMPONENT E

SUBJECT:		CONSTRUCTION NOTES	
Construction Procedures for the Cattle Flow Control Split Gates			
<b>COMPONENTS</b>		<b>ITEM</b>	<b>DETAILED DESCRIPTION</b>
1. Support Posts		1	Cast 100mm of topsoil on the construction area and excavate for the 2 support plated post 400mm x 400mm x 600mm. (Use brics and compare soil re. further collapse)
2. Pneumatic System		2	Supply and install the 2 plated support posts in the excavated holes complete with the hinge mechanisms. (Details of the split gate assembly are specified in drawing no A104/100/2.)
3. Extension Poles & eyes		3	Cast concrete around the posts and compare to ground level as specified and illustrated in drawing no. A104/100/2. Cure concrete by watering and keeping damp.
4. Double Split Gates		4	Supply and Place the Double Split gates as specified complete with all extension poles for connection to the Pneumatic control systems as illustrated in drawing A104/100/1
<b>PURPOSE:</b>		5	Supply and install the 40mm x 100mm rectangular tubing frame as base of pneumatic system. Supply and install the complete system of the Compressed air RAM systems as all materials illustrated in A104/100/1
<b>PROJECT NUMBER:</b>			
<b>DESIGN BY:</b>			
Tereza Justina Matejka Agricultural Engineer			



Agricultural Research Council - Institute for Agricultural Engineering.  
 Institute of Manufacturing and Engineering, Brunel University, Uxbridge, Middlesex UB8 3PH  
 Tel: 01895 200000, Fax: 01895 200001, Email: info@arc.ac.uk, www.arc.ac.uk

INSTITUTE FOR AGRICULTURAL ENGINEERING  
 AGRICULTURAL ENGINEERING COLLEGE

INSTITUUT VR LANDBOU-INGENIEURWESE  
 LANDBOUWINGENIEURWESCHOOL

DESIGNED BY: T. J. MATEJKA	DATE: 20 OCT 2010
CHECKED BY: T. J. MATEJKA	SCALE: 1:10
PROJECT: RFID CATTLE HANDLING SYSTEM	REV. NO.: 00000000
REVISIONS:	2

Figure 10.2 Flow Control double split gates design drawing

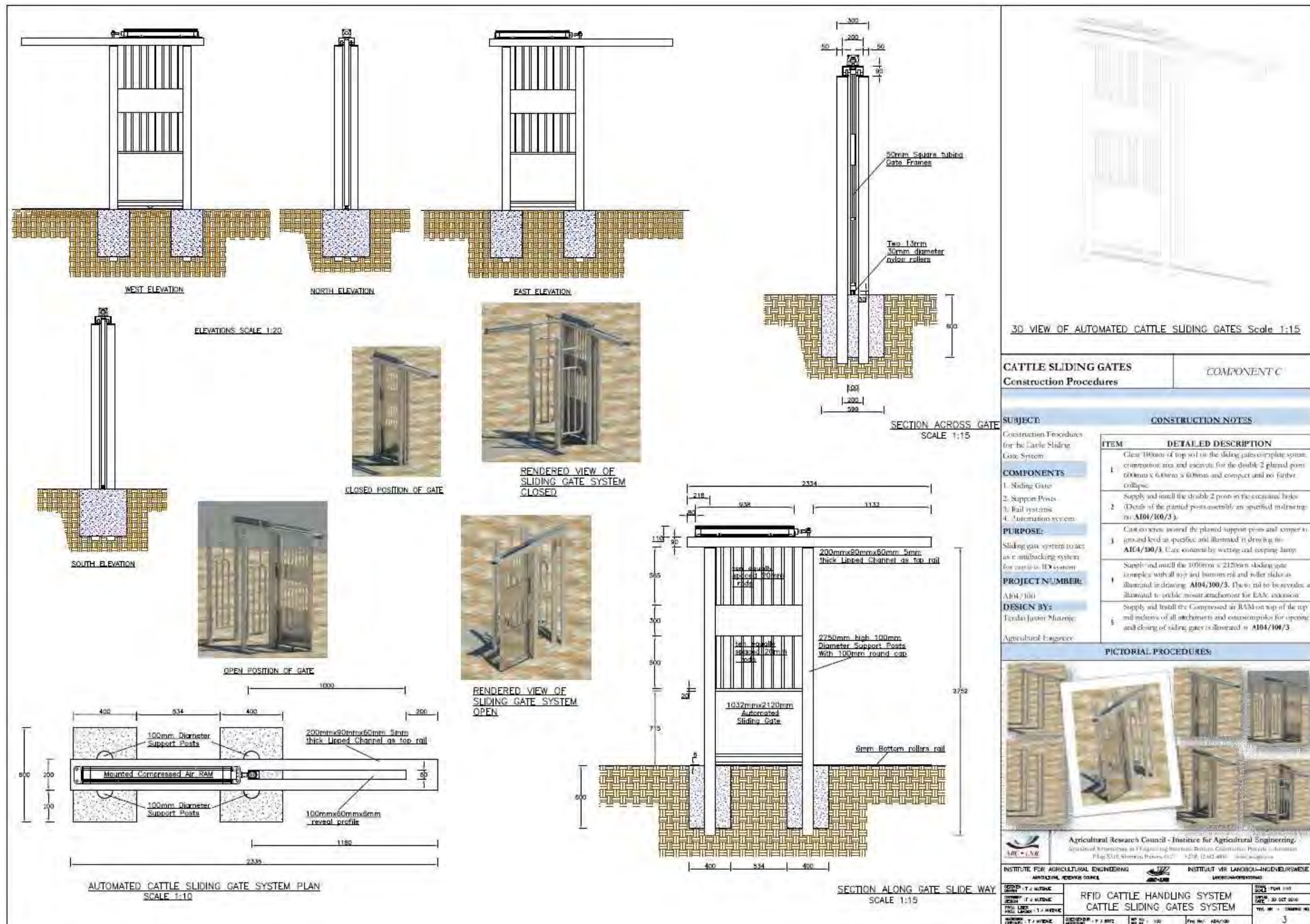

Figure 10.3 Automated sliding gates design drawing

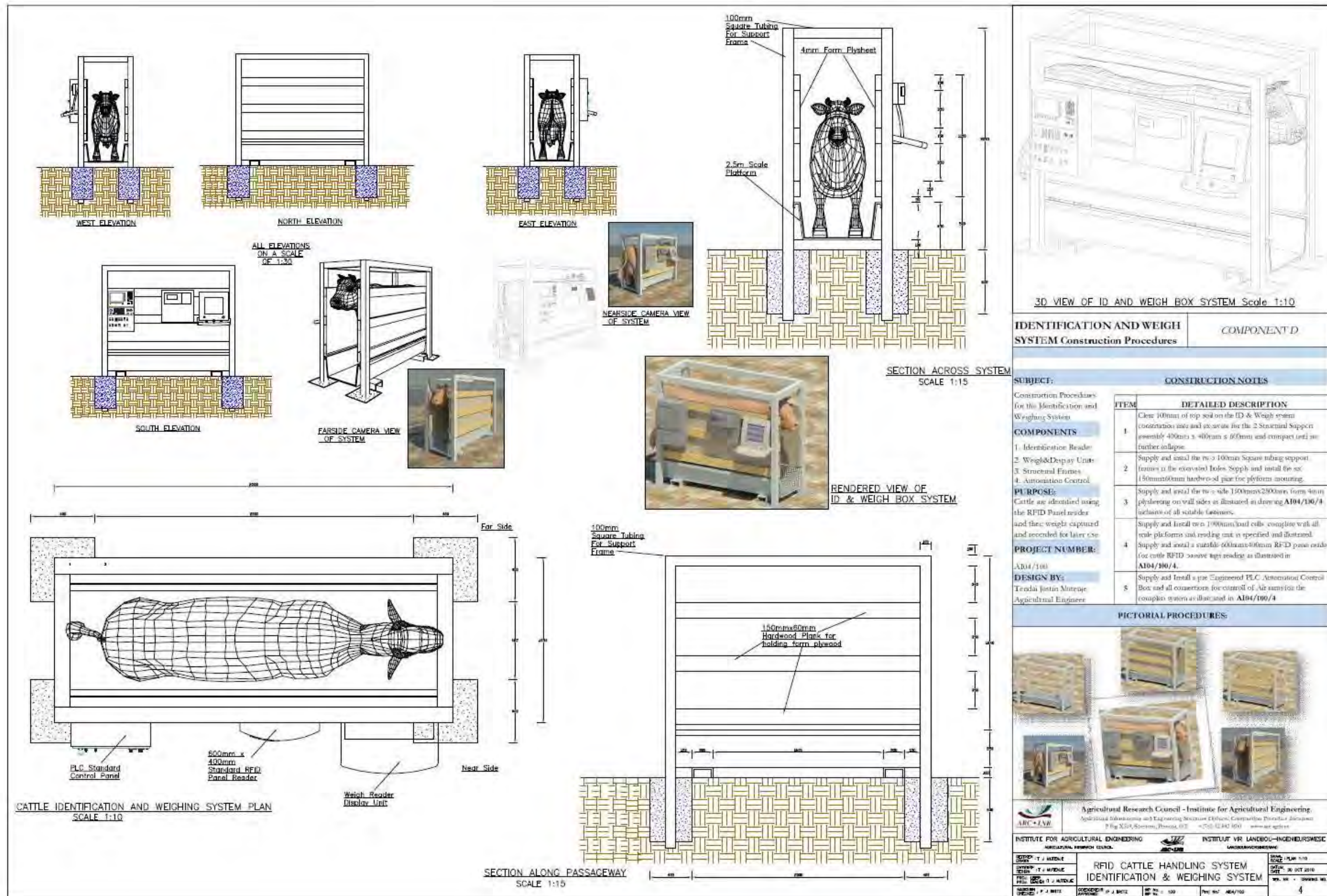

Figure 10.4 ID-weigh box design drawing

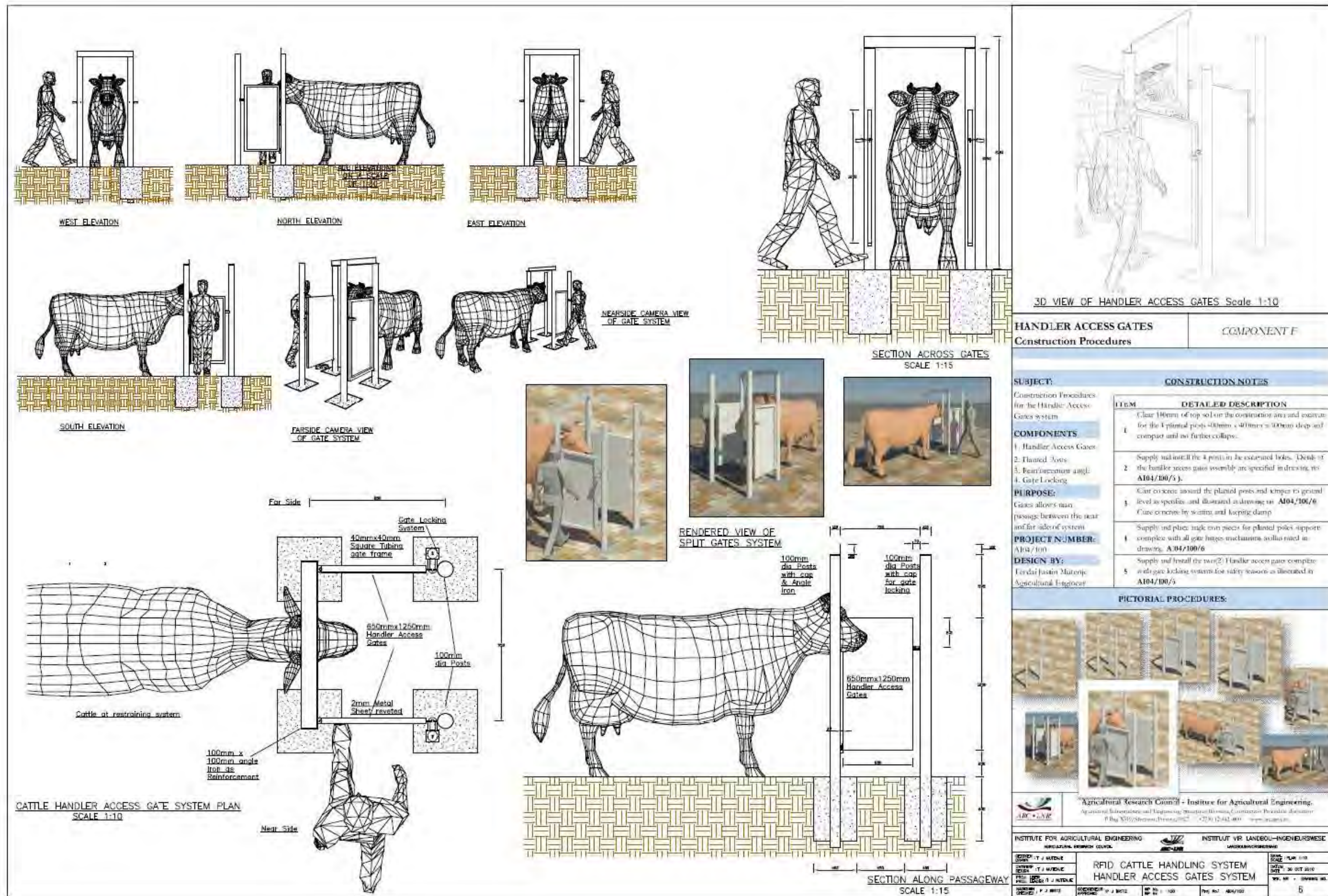

Figure 10.5 Handler access gates design drawing





## 11. APPENDIX C: MODIFIED DRAWINGS FOR CONSTRUCTION

Appendix C contains detailed information provided separately for all modified components included in the design process. The contents are as detailed in Table 11.1.

Table 11.1 Contents of Appendix C: Modified drawing of the developed system

<b>ITEM NO</b>	<b>DETAILED DESCRIPTION OF CONTENT</b>
C1 Figure 11.1	MODIFIED ALLEY PASSAGEWAY FOR CATTLE FLOW INTO RESTRAINING SYSTEM
C2 Figure 11.2	MODIFIED HANDLER ACCESS GATES
C3 Figure 11.3	MODIFIED FLOW CONTROL DOUBLE SPLIT GATES
C4 Figure 11.4	MODIFIED RFID IDENTIFICATION-WEIGH BOX
C5 Figure 11.5	MODIFIED AUTOMATED THREE WAY CATTLE SORTING SYSTEM

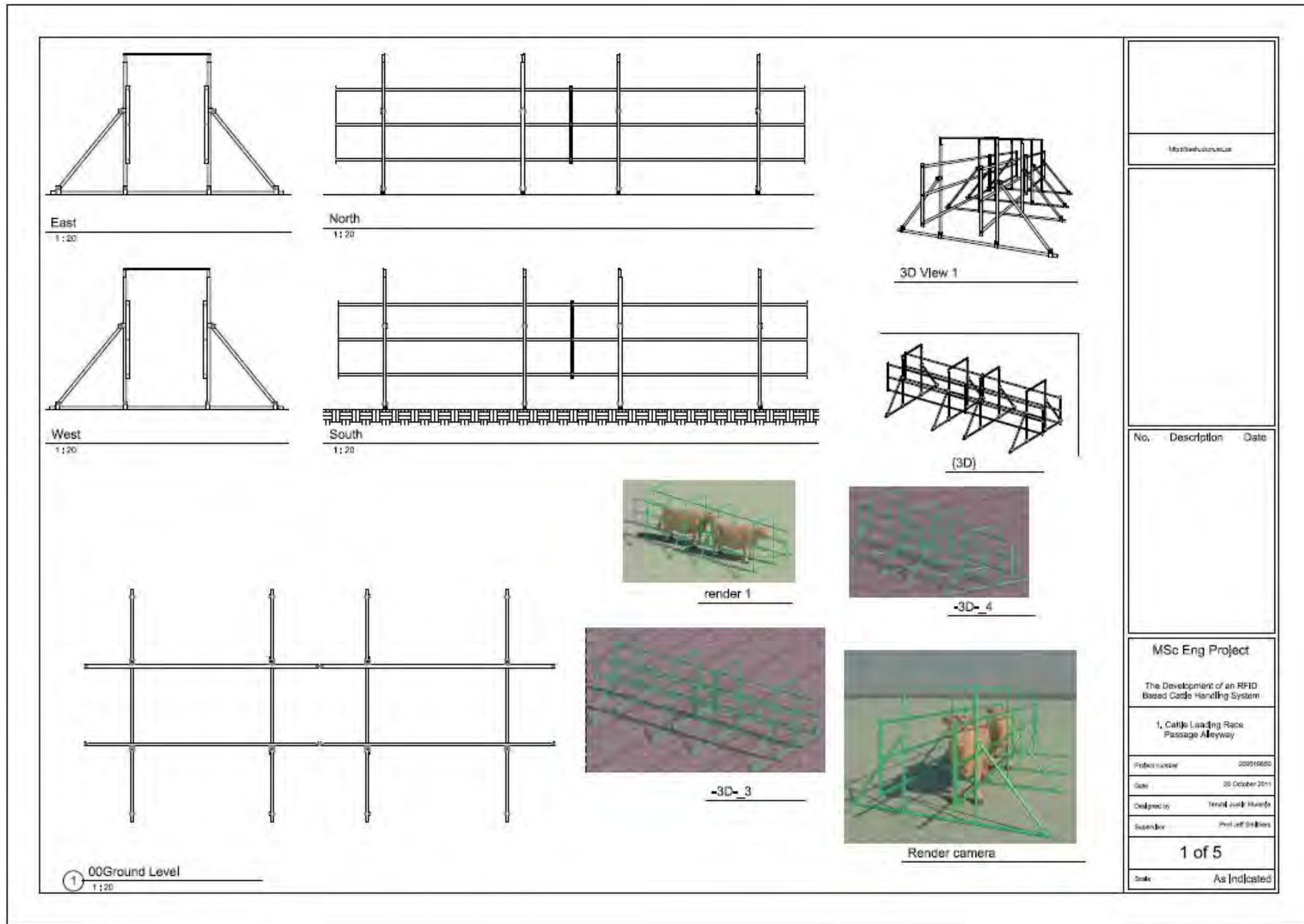

Figure 11.1 Modified alley passageway for cattle flow into restraining system



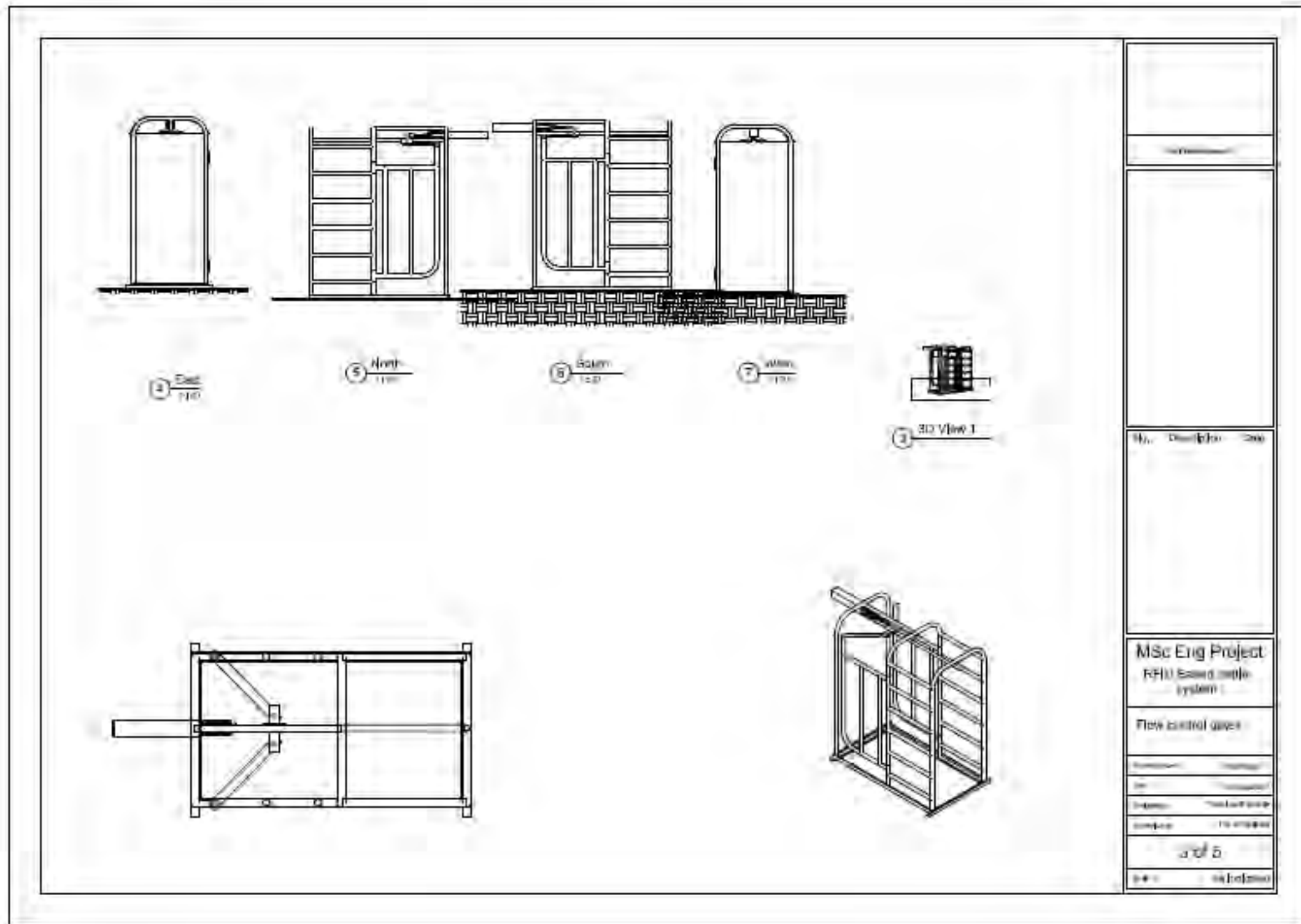

Figure 11.3 Modified flow control double split gates



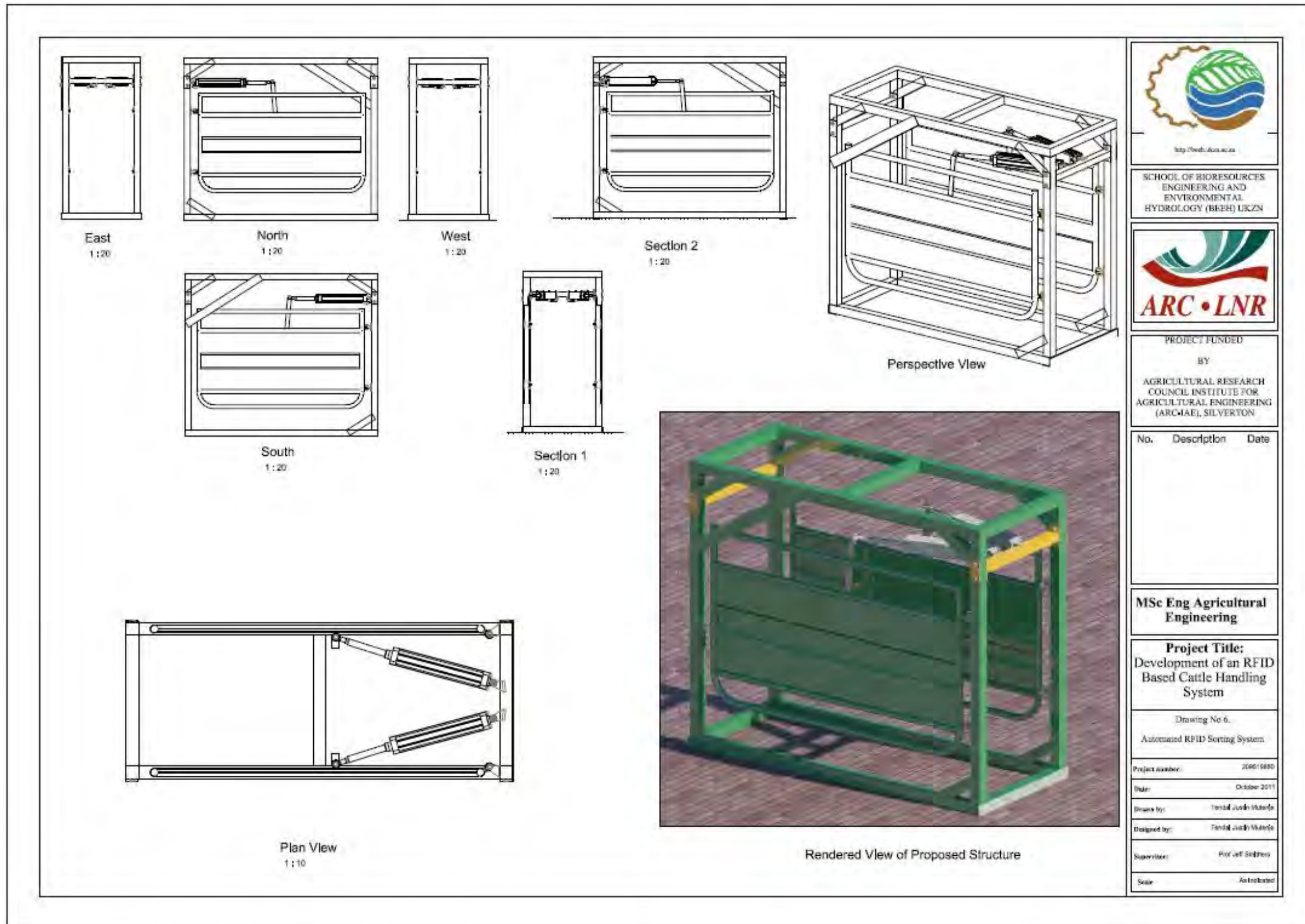

Figure 11.5 Modified automated three way cattle sorting system

**12.APPENDIX D: CONSTRUCTED CATTLE HANDLE SYSTEM**



Figure 12.1 Complete constructed RFID based automated cattle handling system

### 13. APPENDIX E: EVALUATION PROCESS AND OUTPUT DATA

Table 13.1 System evaluation process data collection form

RFID AND MANUAL BASED CATTLE HANDLING DATA COLLECTION AND SYSTEM EVALUATION FORM							
<b>Evaluation Undertaken By:</b>		Tendai Justin Mutenje (Agricultural Engineer)					
<b>Date:</b>	<input style="width: 150px; height: 20px;" type="text"/>	<b>Time:</b>	<input style="width: 150px; height: 20px;" type="text"/>				
<b>Sample No:</b>	<input style="width: 180px; height: 20px;" type="text"/>						
<b>A PERSONAL CHARACTERISTICS</b>							
Characteristics	Unit	Details					
Name of Subject	Full name						
Age	years						
Mass	kg						
<b>B PERSONAL MEASURABLE DETAILS</b>							
Characteristics	Unit	Details					
Blood Pressure	unit						
Pulse	bpm						
Body Temperature	°C						
<b>C EXTERNAL CONDITIONS</b>							
Item No	Details	Before Activity		During Activity		After Activity	
		Manual	RFID	Manual	RFID	Manual	RFID
1	Temp °C						
2	RH %						
Item No	Activity	Time(sec)	Heart rate (bpm)	Breathing frequency			
<b>E INCORRECT SORT CATTLE</b>							



Table 13.2 Day 3 average handling duration results

<b>Handling Area</b>	<b>Average Handling Duration (s)</b>	
	<i>Manual</i>	<i>RFID</i>
Lead Race	5.9	5.7
Flow Control Gates	5.1	1.9
ID -Weigh Box	20.5	4.6
Sorting Gate	10.9	3.3
<b>Total Average</b>	<b>42.4</b>	<b>15.5</b>

Table 13.3 Day 6 average handling duration results

<b>Handling Area</b>	<b>Average Handling Duration (s)</b>	
	<i>Manual</i>	<i>RFID</i>
Lead Race	5.4	5.2
Flow Control Gates	4.6	1.8
ID -Weigh Box	18.7	4.2
Sorting Gate	9.9	3.1
<b>Total Average</b>	<b>38.6</b>	<b>14.3</b>

Table 13.4 Day 10 average handling duration results

<b>Handling Area</b>	<b>Average Handling Duration (s)</b>	
	<i>Manual</i>	<i>RFID</i>
Lead Race	4.5	4.3
Flow Control Gates	3.8	1.5
ID -Weigh Box	15.5	3.5
Sorting Gate	8.3	2.5
<b>Total Average</b>	<b>32.1</b>	<b>11.8</b>

Table 13.5 Sessional total handling duration for the developed system

Test Day	Handling Duration	
	Manual	RFID
1	1151.94	456.1
2	1101.08	402.9
3	1078.19	392.8
4	1022.25	362.4
5	1004.45	359.8
6	981.563	359.8
7	821.36	301.5
8	828.989	304.1
9	823.903	301.5
10	816.274	299
<b>Total</b>	<b>9630</b>	<b>3540</b>
<i>Mean</i>	<i>963</i>	<i>354</i>

Table 13.6 Handler work physiology data obtained from systems evaluation

Test Day	Handling Duration		Heart rate		Energy expenditure		TCCW		PCW	
	Manual	RFID	Manual	RFID	Manual	RFID	Manual	RFID	Manual	RFID
1	45.3	18	138.0	122.8	11.22	8.03	901.39	741.27	21.94	16.93
2	43.3	15.9	131.9	108.5	10.72	7.09	861.60	708.54	20.97	16.18
3	42.4	15.5	129.1	105.7	10.50	6.91	843.69	693.82	20.53	15.84
4	40.2	14.3	122.4	97.6	9.96	6.38	799.91	657.82	19.47	15.02
5	39.5	14.2	120.3	96.9	8.56	6.33	785.98	646.36	19.13	14.76
6	38.6	14.2	117.6	96.9	9.56	6.33	768.08	631.64	18.69	14.42
7	32.3	11.9	98.4	81.2	8.00	5.31	642.72	528.54	15.64	12.07
8	32.6	12	99.3	81.9	8.07	5.35	648.69	533.45	15.79	12.18
9	32.4	11.9	98.7	81.2	8.03	5.31	644.71	530.18	15.69	12.11
10	32.1	11.8	97.8	80.5	7.95	5.26	638.74	525.27	15.55	11.99
<b>Total</b>	<b>378.7</b>	<b>139.7</b>	<b>1153.4</b>	<b>953.1</b>	<b>92.57</b>	<b>62.30</b>	<b>7535.50</b>	<b>6196.90</b>	<b>183.40</b>	<b>141.50</b>
<i>Mean</i>	<i>37.87</i>	<i>13.97</i>	<i>115.3</i>	<i>95.3</i>	<i>9.26</i>	<i>6.23</i>	<i>753.55</i>	<i>619.69</i>	<i>18.34</i>	<i>14.15</i>

Table 13.7 Cattle work physiology data obtained from systems evaluation

Test Day	Breathing Frequency		Heart rate	
	Manual	RFID	Manual	RFID
1	15.5	14.7	113.5	108.0
2	14.8	13.0	108.5	95.4
3	14.5	12.6	106.3	93.0
4	13.7	11.7	100.7	85.8
5	13.5	11.6	99.0	85.2
6	13.2	11.6	96.7	85.2
7	11.0	9.7	81.0	71.4
8	11.1	9.8	81.7	72.0
9	11.1	9.7	81.2	71.4
10	11.0	9.6	80.4	70.8
<b>Total</b>	<b>129.2</b>	<b>114.0</b>	<b>949.1</b>	<b>838.2</b>
<i>Mean</i>	<i>12.9</i>	<i>11.4</i>	<i>94.9</i>	<i>83.8</i>

Paired t test			
Does the mean of the differences between Manual systems and Automated systems differ significantly from zero?			
<u>P value</u>			
The two-tailed P value is < 0.0001, considered extremely significant.			
t = 24.353 with 9 degrees of freedom.			
<u>95% confidence interval</u>			
Mean difference = 23.900 (Mean of paired differences)			
The 95% confidence interval of the difference: 21.680 to 26.120			
<u>Assumption test: Was the pairing effective?</u>			
Correlation coefficient (r) = 0.9760			
The one-tailed P value is < 0.0001, considered extremely significant.			
Effective pairing results in a significant correlation between the columns.			
With these data, the pairing (or matching) appears to be effective.			
<u>Assumption test: Are the differences sampled from a Gaussian distribution?</u>			
The paired t test assumes that the differences are sampled from a Gaussian distribution. This assumption is tested using the method of Kolmogorov and Smirnov:			
The Kolmogorov-Smirnov distance (KS) is 0.26			
The P value is 0.0618The data passed the normality test with P>0.05.			
Summary of Data			
Parameter:	Manual systems	Automated systems	Difference
Mean:	37.870	13.970	23.900
# of points:	10	10	10
Std deviation:	5.119	2.100	3.103
Std error:	1.619	0.6640	0.9814
Minimum:	32.100	11.800	20.300
Maximum:	45.300	18.000	27.400
Median:	39.050	14.200	24.850
Lower 95% CI:	34.208	12.468	21.680
Upper 95% CI:	41.532	15.472	26.120
	*	*	*

Figure 13.1 Significance test results extract from Graph Pad InStat software

Paired t test			
Does the mean of the differences between Manual Heart RT and RFID Heart Rate differ significantly from zero?			
<u>P value</u>			
The two-tailed P value is < 0.0001, considered extremely significant.			
t = 18.169 with 9 degrees of freedom.			
<u>95% confidence interval</u>			
Mean difference = 20.030 (Mean of paired differences)			
The 95% confidence interval of the difference: 17.536 to 22.524			
<u>Assumption test: Was the pairing effective?</u>			
Correlation coefficient (r) = 0.9763			
The one-tailed P value is < 0.0001, considered extremely significant.			
Effective pairing results in a significant correlation between the columns.			
With these data, the pairing (or matching) appears to be effective.			
<u>Assumption test: Are the differences sampled from a Gaussian distribution?</u>			
The paired t test assumes that the differences are sampled from a Gaussian distribution. This assumption is tested using the method of Kolmogorov and Smirnov:			
The Kolmogorov-Smirnov distance (KS) is 0.27			
The P value is 0.0434			
The data failed the normality test with P<0.05.			
Consider using a nonparametric test or transforming the data (i.e. converting to logarithms or reciprocals).			
Summary of Data			
Parameter:	Manual Heart RT	RFID Heart Rate	Difference
Mean:	115.35	95.320	20.030
# of points:	10	10	10
Std deviation:	15.583	14.319	3.486
Std error:	4.928	4.528	1.102
Minimum:	97.800	80.500	15.200
Maximum:	138.00	122.80	24.800
Median:	118.95	96.900	19.100
Lower 95% CI:	104.20	85.078	17.536
Upper 95% CI:	126.50	105.56	22.524

Figure 13.2 Significance test for heart rate results obtained

Paired t test			
Does the mean of the differences between Manual Energy E and RFID Energy Exp differ significantly from zero?			
<u>P value</u>			
The two-tailed P value is < 0.0001, considered extremely significant.			
t = 19.793 with 9 degrees of freedom.			
<u>95% confidence interval</u>			
Mean difference = 3.027 (Mean of paired differences)			
The 95% confidence interval of the difference: 2.681 to 3.373			
<u>Assumption test: Was the pairing effective?</u>			
Correlation coefficient (r) = 0.9526			
The one-tailed P value is < 0.0001, considered extremely significant.			
Effective pairing results in a significant correlation between the columns.			
With these data, the pairing (or matching) appears to be effective.			
<u>Assumption test: Are the differences sampled from a Gaussian distribution?</u>			
The paired t test assumes that the differences are sampled from a Gaussian distribution. This assumption is tested using the method of Kolmogorov and Smirnov:			
The Kolmogorov-Smirnov distance (KS) is 0.24			
The P value is >0.10The data passed the normality test with P>0.05.			
Summary of Data			
Parameter:	Manual Energy E	RFID Energy Exp	Difference
Mean:	9.257	6.230	3.027
# of points:	10	10	10
Std deviation:	1.283	0.9365	0.4836
Std error:	0.4057	0.2961	0.1529
Minimum:	7.950	5.260	2.230
Maximum:	11.220	8.030	3.630
Median:	9.060	6.330	2.955
Lower 95% CI:	8.339	5.560	2.681
Upper 95% CI:	10.175	6.900	3.373

Figure 13.3 Significance test for energy expenditure of the two systems

Paired t test			
Does the mean of the differences between Manual TCCW and RFID TCCW differ significantly from zero?			
<u>P value</u>			
The two-tailed P value is < 0.0001, considered extremely significant.			
t = 23.399 with 9 degrees of freedom.			
<u>95% confidence interval</u>			
Mean difference = 133.86 (Mean of paired differences)			
The 95% confidence interval of the difference: 120.92 to 146.80			
<u>Assumption test: Was the pairing effective?</u>			
Correlation coefficient (r) = 1.0000			
The one-tailed P value is < 0.0001, considered extremely significant.			
Effective pairing results in a significant correlation between the columns.			
With these data, the pairing (or matching) appears to be effective.			
<u>Assumption test: Are the differences sampled from a Gaussian distribution?</u>			
The paired t test assumes that the differences are sampled from a Gaussian distribution. This assumption is tested using the method of Kolmogorov and Smirnov:			
The Kolmogorov-Smirnov distance (KS) is 0.25			
The P value is 0.0810The data passed the normality test with P>0.05.			
Summary of Data			
<b>Parameter:</b>	<b>Manual TCCW</b>	<b>RFID TCCW</b>	<b>Difference</b>
Mean:	753.55	619.69	133.86
# of points:	10	10	10
Std deviation:	101.86	83.767	18.091
Std error:	32.210	26.489	5.721
Minimum:	638.74	525.27	113.47
Maximum:	901.39	741.27	160.12
Median:	777.03	639.00	138.03
Lower 95% CI:	680.69	559.77	120.92
Upper 95% CI:	826.41	679.61	146.80

Figure 13.4 Significance test for total cardiac cost of work of the two systems

Paired t test			
Does the mean of the differences between Manual PCW and RFID PCW differ significantly from zero?			
<u>P value</u>			
The two-tailed P value is < 0.0001, considered extremely significant.			
t = 23.429 with 9 degrees of freedom.			
<u>95% confidence interval</u>			
Mean difference = 4.190 (Mean of paired differences)			
The 95% confidence interval of the difference: 3.785 to 4.595			
<u>Assumption test: Was the pairing effective?</u>			
Correlation coefficient (r) = 1.0000			
The one-tailed P value is < 0.0001, considered extremely significant.			
Effective pairing results in a significant correlation between the columns.			
With these data, the pairing (or matching) appears to be effective.			
<u>Assumption test: Are the differences sampled from a Gaussian distribution?</u>			
The paired t test assumes that the differences are sampled from a Gaussian distribution. This assumption is tested using the method of Kolmogorov and Smirnov:			
The Kolmogorov-Smirnov distance (KS) is 0.25			
The P value is 0.0835The data passed the normality test with P>0.05.			
Summary of Data			
Parameter:	Manual PCW	RFID PCW	Difference
Mean:	18.340	14.150	4.190
# of points:	10	10	10
Std deviation:	2.479	1.913	0.5655
Std error:	0.7838	0.6050	0.1788
Minimum:	15.550	11.990	3.560
Maximum:	21.940	16.930	5.010
Median:	18.910	14.590	4.320
Lower 95% CI:	16.567	12.781	3.785
Upper 95% CI:	20.113	15.519	4.595

Figure 13.5 Significance test for physiological cost of work of the two systems



Paired t test			
Does the mean of the differences between Manual Breath f and RFID Breath fre differ significantly from zero?			
<u>P value</u>			
The two-tailed P value is < 0.0001, considered extremely significant.			
t = 13.099 with 9 degrees of freedom.			
<u>95% confidence interval</u>			
Mean difference = 1.540 (Mean of paired differences)			
The 95% confidence interval of the difference: 1.274 to 1.806			
<u>Assumption test: Was the pairing effective?</u>			
Correlation coefficient (r) = 0.9773			
The one-tailed P value is < 0.0001, considered extremely significant.			
Effective pairing results in a significant correlation between the columns.			
With these data, the pairing (or matching) appears to be effective.			
<u>Assumption test: Are the differences sampled from a Gaussian distribution?</u>			
The paired t test assumes that the differences are sampled from a Gaussian distribution. This assumption is tested using the method of Kolmogorov and Smirnov:			
The Kolmogorov-Smirnov distance (KS) is 0.16			
The P value is >0.10The data passed the normality test with P>0.05.			
Summary of Data			
<b>Parameter:</b>	<b>Manual Breath f</b>	<b>RFID Breath fre</b>	<b>Difference</b>
Mean:	12.940	11.400	1.540
# of points:	10	10	10
Std deviation:	1.754	1.720	0.3718
Std error:	0.5548	0.5441	0.1176
Minimum:	11.000	9.600	0.8000
Maximum:	15.500	14.700	2.000
Median:	13.350	11.600	1.500
Lower 95% CI:	11.685	10.169	1.274
Upper 95% CI:	14.195	12.631	1.806

Figure 13.6 Significance test for cattle breathing frequency for the two systems

Paired t test			
Does the mean of the differences between Manual Heart RT and RFID Heart RT differ significantly from zero?			
<u>P value</u>			
The two-tailed P value is < 0.0001, considered extremely significant.			
t = 12.542 with 9 degrees of freedom.			
<u>95% confidence interval</u>			
Mean difference = 11.080 (Mean of paired differences)			
The 95% confidence interval of the difference: 9.082 to 13.078			
<u>Assumption test: Was the pairing effective?</u>			
Correlation coefficient (r) = 0.9760			
The one-tailed P value is < 0.0001, considered extremely significant.			
Effective pairing results in a significant correlation between the columns.			
With these data, the pairing (or matching) appears to be effective.			
<u>Assumption test: Are the differences sampled from a Gaussian distribution?</u>			
The paired t test assumes that the differences are sampled from a Gaussian distribution. This assumption is tested using the method of Kolmogorov and Smirnov:			
The Kolmogorov-Smirnov distance (KS) is 0.20			
The P value is >0.10The data passed the normality test with P>0.05.			
Summary of Data			
<b>Parameter:</b>	<b>Manual Heart RT</b>	<b>RFID Heart RT</b>	<b>Difference</b>
Mean:	94.900	83.820	11.080
# of points:	10	10	10
Std deviation:	12.823	12.599	2.794
Std error:	4.055	3.984	0.8834
Minimum:	80.400	70.800	5.500
Maximum:	113.50	108.00	14.900
Median:	97.850	85.200	10.650
Lower 95% CI:	85.727	74.808	9.082
Upper 95% CI:	104.07	92.832	13.078

Figure 13.7 Significance test for cattle heart rate for the two systems

File <b>AI04-BOX SHAPED CRUSH</b>	Project Title: Research and Development of an RFID controlled cattle handling technology system prototype	Date <b>30 August 2010</b>
--------------------------------------	--	-------------------------------

By: Tendai Justin Mutenje	Reviewed:	Subject: BOX SHAPED CATTLE CRUSH SYSTEM	Page: COVER PAGE
------------------------------	-----------	--	---------------------

Units Listed     
 Numbers Checked     
 Sources Referenced     
 Inputs Listed

Item	Design Title:	Chk
	<p><b>DESIGN NOTES</b></p> <p><b>FOR THE</b></p> <p><b>BOX SHAPED CATTLE CRUSH</b></p> <p><b>PASSAGE / ALLEY</b></p> <p><b>26 PAGES</b></p>	
	To page: 1	

Designed By: Tendai Justin MUTENJE	Date: 30 Aug 2010	Checked By:	Date:
---------------------------------------	----------------------	-------------	-------



Agricultural Research Council - Institute for Agricultural Engineering.  
Agricultural Infrastructure and Engineering Structures Division, Design & Calcs, Modeling, Design & Drafting  
P Bag X519, Silverton, Pretoria, 0127 +27(0) 12 842 4000 www.arc.agric.za

File AI04- Box SHAPED CRUSH	Project Title: Research and Development of an RFID controlled cattle handling technology system prototype	Date 30 Aug 2010
--------------------------------	--	---------------------

By: MUTENJE	Reviewed:	Subject: BOX SHAPED CRUSH ASSEMBLY DESIGN	Page: COVER
----------------	-----------	--	----------------

Units Listed   
 Numbers Checked   
 Sources Referenced   
 Inputs Listed

Item	Design Title:  <p style="text-align: center;">BOX SHAPED CRUSH ASSEMBLY DESIGN</p> <p style="text-align: center;">DESIGN NOTES</p> <p style="text-align: center;">FOR</p> <p style="text-align: center;">THE</p> <p style="text-align: center;">BOX SHAPED CATTLE CRUSH</p> <p style="text-align: center;">PASSAGEWAY / ALLEY</p> <p style="text-align: center;">26 PAGES</p>	Chk
	To page: 1	

Designed By: Tendai Justin Mutenje	Date: 30 Aug 2010	Checked By:	Date:
---------------------------------------	----------------------	-------------	-------

File AI04- Boxes MAPED CRUSH	Project Title: Research and Development of an RFID controlled cattle handling technology system prototype	Date 01 Sept 2010
------------------------------------	--	----------------------

By: T J Mutenje	Reviewed:	Subject: Cattle Crush Design Details	Page: 1
--------------------	-----------	---	------------

Units Listed   
 Numbers Checked   
 Sources Referenced   
 Inputs Listed

Item	Design Title: <u>Cattle Crush: Passage Way Design</u>	Chk
------	---	-----

Design Problems (Notes 1) ⊗ key features

- ① Unpredictable cattle behaviour in facility
  - May be caused by Contrasting light levels of the ⊗  
crush design finish and colours
- ② Cattle flow problems caused by Wall design
  - Uprights distracting flow
  - Overlapping sheets causing harm to livestock.
  - Screws & sharp objects protrusions
  - Cattle jumping outside crush passage ⊗
- ③ Cattle Slip along passage &
  - Slip during handling
  - Cattle lying down in passage ⊗
  - Cattle turning
- ④ Slope along crush affecting flow
  - Poor drainage & dung removal systems
- ⑤ Bruises & Leg Injuries
  - Sharp angled corners causing injuries
  - Gap between floor and wall too big/small ⊗
  - Legs being trapped in gaps
- ⑥ Race Dimension affecting flow
  - Passage allowing cattle to turn
  - Area of passage too narrow for cattle flow } ⊗

6 Design factors: Literature to solve on page 2 To page: 2

Designed By: T J MUTENJE	Date: 30 Sept 2010	Checked By:	Date:
-----------------------------	-----------------------	-------------	-------

File AI04- Box SHAPED CRUSH	Project Title: Research and Development of an RFID controlled cattle handling technology system prototype	Date 01 Sept 2010
By: TJ Mutenje	Reviewed:	Subject: CATTLE Crush Design Details
		Page: 2
<input type="checkbox"/> Units Listed <input type="checkbox"/> Numbers Checked <input type="checkbox"/> Sources Referenced <input type="checkbox"/> Inputs Listed		
Item	Design Title: <u>From Page 1 : Cattle crush Passageway Design</u>	Chk
	<u>DESIGN SOLUTIONS FROM LITERATURE</u> <p>① <u>Contrasting light levels</u>  a) <u>Grandin (1980)</u>: (ref)  Animal (Cattle) infrastructure to have uniform <sup>colour,</sup> texture and level to reduce areas of stark contrast.</p> <p>② <u>Apple K (1994)</u>: (ref) - Hot dip galvanised widely acceptable in facilities  Conclusion: Uniform Silver colour/Green/rust brown &amp; metal finish (Hot dip Galvanised finish)</p> <p>③ <u>SABS (2010)</u>:  SABS standard (Ref): SABS 1431 - Fabrication  SABS 1200-H-1990 - Structural steel work  SABS 435 - Steel Reverts and fasteners.  SABS 763:1997 - Hot dip galvanised coatings <sup>⊗</sup> sheets  SABS 4998:1996 - Continuous hot dip zinc coated steel</p> <p>④ <u>Hot Dip Galvanizers Association South Africa (2010)</u>:  HDGASA (2010): (ref) Hot dip galvanise after fabricating before installation.  * not centrifuged adopt SABS 763 or SANS 121/ISO 1461</p> <p>⑤ <u>ISO (2010)</u>:  ISO Standard (Ref): ISO 1461:1999 - Hot dip galvanised coating on steel  SANS (121)                      ISO 14713:1999 - Protection against corrosion (steel)</p> <p><u>Design Statement</u></p> <p>- Equipment steel hot dipped galvanizing for corrosion protection reasons (All components be hot dipped galvanised to conform to ISO 1461 or SANS 121 or SABS 763)</p>	
Carried to <u>PS1e</u>	Final Specification: Ref PS1@ * All steel work to be of uniform colour, texture and level to avoid stark contrast and to be hot dip galvanised to SABS 763/SANS 121/ISO 1461. Coating Quality minimum A1-A3 (55µm - 25µm) To page: 3	
Designed By: T J Mutenje	Date: 01/09/2010	Checked By: Date:
 Agricultural Research Council - Institute for Agricultural Engineering. Agricultural Infrastructure and Engineering Structures Division, Design & Cales, Modeling, Design & Drafting P Bag X519, Silverton, Pretoria, 0127 +27(0) 12 842 4000 www.arc.agric.za		

File AI04- Box SHAPED CRUSH	Project Title: Research and Development of an RFID controlled cattle handling technology system prototype	Date 01 Sept 2010
-----------------------------------	---	----------------------

By: TJ Mutenje	Reviewed:	Subject: CATTLE CRUSH DESIGN DETAILS	Page: 3
-------------------	-----------	---	------------

<input type="checkbox"/> Units Listed	<input type="checkbox"/> Numbers Checked	<input type="checkbox"/> Sources Referenced	<input type="checkbox"/> Inputs Listed
---------------------------------------	--	---	--

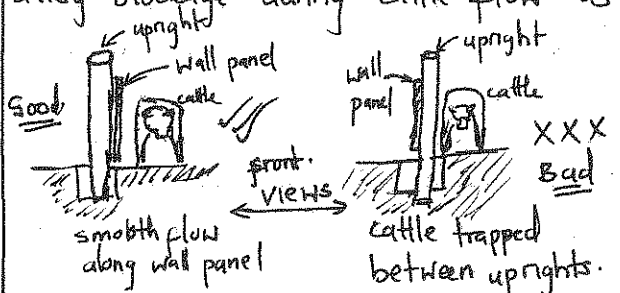
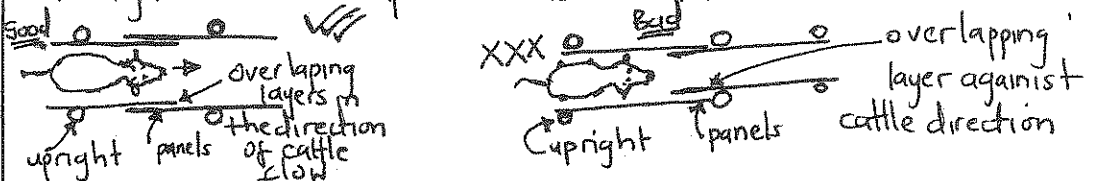
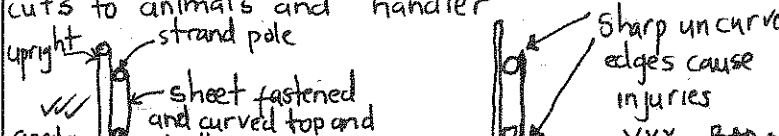
Item	Design Title: <u>Cattle Passageway Design</u>	Chk		
	<p><u>DESIGN SOLUTIONS FROM LITERATURE</u></p> <p>② <u>Crush Wall design</u></p> <p>ⓐ <u>Brockway (1983): (ref)</u> Uprights should be on the outside of the crush passageway to avoid alley blockage during cattle flow as illustrated below</p>  <p><u>Outcomes:</u> ⊕ Uprights to be on the outside and wall panels on the cattle side</p> <p>ⓑ <u>Meadowcroft (1990): (ref)</u> Overlapping sheets to be in the direction of cattle movement to avoid cattle injuries and entrapments as illustrated below</p>  <p><u>Outcome:</u> ⊕ Overlapping sheets to be following the direction of cattle flow</p> <p>ⓒ <u>Grandin (1997): (ref)</u> Thin sheets should be curved over along top and bottom to prevent cuts to animals and handler</p>  <p><u>Outcome:</u> sheets should be curved over along top and bottom to prevent injuries</p>			
	Designed By: <u>TJ MUTENJE</u>	Date: <u>01/09/2010</u>	Checked By:	Date:

To page: 4



File AI04-Box SHAPED CRUSH	Project Title: Research and Development of an RFID controlled cattle handling technology system prototype	Date 01 SEPT 2010
----------------------------------	---	----------------------

By: T J Mutenje	Reviewed:	Subject: CATTLE CRUSH DESIGN DETAILS	Page: 4
--------------------	-----------	---	------------

Units Listed   
 Numbers Checked   
 Sources Referenced   
 Inputs Listed

Item	Design Title: <u>Cattle Passageway design</u> : Continue from page 3	Chk
------	--	-----

Design solution from literature

① Broadway (1983): (ref)

Screws to be countersunk to avoid bruises and injuries

Outcome:  
Countersunk  
screws & fasteners

② Hardy (1990): (ref)

Walls to be approximately between 1,59-1,80m for most breeds but  $\approx$  1,68 high for most south African local breeds to avoid jumpers and ease of operations by handler

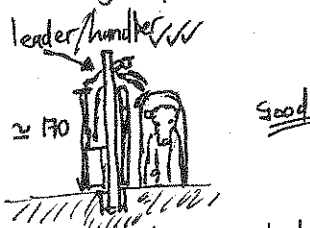

avoids jumpers but allow handler to work

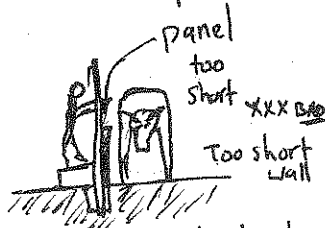

prone to jumpers and not economically friendly to handler

\* Outcome:

Cattle panel walls for SA to be approximately  $\approx$  160-170cm above ground high

③ Grandin (1997): (ref)

Use solid walls for side panels to limit visual disturbance and reduce the risk of jumpers.

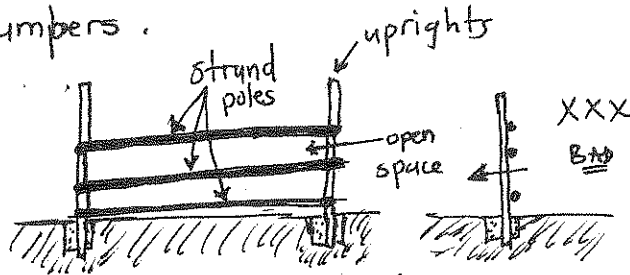
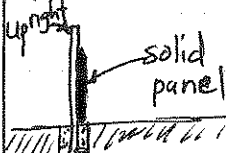
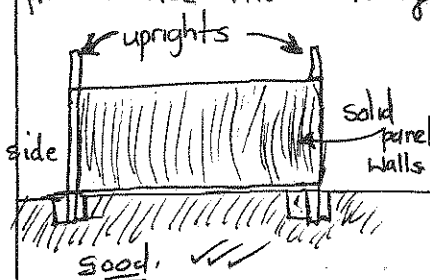

Outcome:

Use solid panels for passage walls to avoid visual disturbance.

Continue to 5

To page: 5

Designed By: T J MUTENJE	Date: 01/09/2010	Checked By:	Date:
-----------------------------	---------------------	-------------	-------





File AI04-Box SHAPED CRUSH	Project Title: Research and Development of an RFID controlled cattle handling technology system prototype	Date 01 SEPT 2010
By: T J MUTENJE	Reviewed: Subject: CATTLE CRUSH DESIGN DETAILS	Page: 5
<input type="checkbox"/> Units Listed <input type="checkbox"/> Numbers Checked <input type="checkbox"/> Sources Referenced <input type="checkbox"/> Inputs Listed		
Item	Design Title: <u>Cattle passageway design: continue from page 4</u> <u>Design Solution from Literature</u>  <u>Final Specification: Ref PS1b</u>  Carried to PS1b { <ul style="list-style-type: none"> <li>⊛ Uprights to be constructed on the outside and wall panels on the cattle side</li> <li>• Overlapping sheets to be in the direction of cattle flow</li> <li>• Sheets to be curved over along top and bottom to prevent injuries</li> <li>• All screws and fasteners to be countersunk to avoid bruises and injuries</li> <li>• Cattle panel walls to be constructed to a height of <math>1.65</math> above ground/cattle floor</li> <li>• Use solid panels for crush walls to minimise outside visual disturbances and reduce risk of jumpers.</li> </ul>	Chk
		To page: 6
Designed By: T J MUTENJE	Date: 01/09/2010	Checked By: Date:

File AI04- Box SHAPED CRUSH	Project Title: Research and Development of an RFID controlled cattle handling technology system prototype	Date 01 SEPT 2010
-----------------------------------	---	----------------------

By: TJ MUTENJE	Reviewed:	Subject: CRUSH DESIGN DETAILS	Page: 6
-------------------	-----------	----------------------------------	------------

Units Listed     Numbers Checked     Sources Referenced     Inputs Listed

Item	Design Title: <u>Crush Passageway Design</u>	Chk
------	--	-----

Design Solutions From Literature

③ Floor Surfaces

① Mc Nitt (1983) - (ref) \*Bicudo et al (2002) ref \*Boyles et al (2008)  
 \*Crush floor to have generally a 4% longitudinal slope for drainage. \*Cattle hate moving down thus slope < 5% to be used.  
Outcome:

Crush floor to adopt an  $\approx 4\%$  longitudinal slope for drainage.

② Weeks et al (2002): (ref)

V shaped grooves of 2,5cm depth arranged in 20cm diamond and square pattern <sup>if can</sup> be effectively used for concrete surfaces to avoid slip.

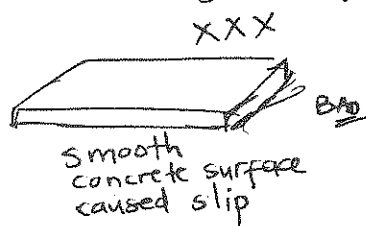
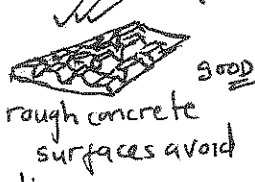

Outcome:  
 Concrete surfaces to have a rough finish to avoid slip

③ Grandin (1999): ref

To avoid slip or use 2,5cm steel rods placed in concrete slightly protruding above concrete surface to increase grip.

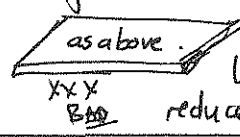
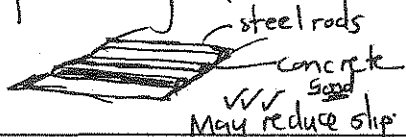

Outcome:  
 Use steel rods to reduce slip

Final Specification: Ref PS1c

- Carried to PS1c
- Slope to be constructed with a general longitudinal slope of  $\approx 4\%$
  - Make use of 2,5cm steel rods placed slightly above concrete for grip
  - Use 2,5cm deep grooves arranged 20cm diamond and square pattern to avoid slip

To page: 7

Designed By: T J MUTENJE	Date: 01/09/2010	Checked By:	Date:
-----------------------------	---------------------	-------------	-------



File AI04- BOX SHAPED CRUSH	Project Title: Research and Development of an RFID controlled cattle handling technology system prototype	Date 01 SEPT 2010
By: TJ MUTENJE	Reviewed: Subject: CATTLE CRUSH DESIGN DETAILS	Page: 7

Units Listed   
 Numbers Checked   
 Sources Referenced   
 Inputs Listed

Item	<p>Design Title: <u>CRUSH Passageway Design</u></p> <p><u>Design Solution From Literature</u></p> <p>④ <u>Avoidance of Bruises and leg Injuries</u></p> <p>ⓐ <u>Marshal (1977)(ref), Grandin (1990)(ref), Weeks et.al(2002)</u></p> <p>Sharp angled corners to be avoided and replaced by round posts and poles</p> <p>Outcome: Make use of round uprights and strand poles to avoid injuries</p> <p>Sharp angles piece animal and handler thro to be avoided</p> <p>Round poles and Posts aid flow and reduce injuries.</p> <p>ⓑ <u>Weeks et al (2002) (ref)</u></p> <p>Allow a gap of between 8cm-10cm between floor and wall bottom for drainage and dung removal. Gap not to be large enough to cause injuries to cattle feet or being trapped as illustrated below</p> <p>Outcome: Allow a maximum of 100mm gap between crush wall and floor for drainage and avoidance of cattle trap</p>	Chk
------	---	-----

Designed By: T J MUTENJE	Date: 01/09/2010	Checked By:	Date:
-----------------------------	---------------------	-------------	-------

File AI04-BOX SHAPED CRUSH	Project Title: Research and Development of an RFID controlled cattle handling technology system prototype	Date 01 SEPT 2010
----------------------------------	---	----------------------

By: TJ MUTENJE	Reviewed:	Subject: CATTLE CRUSH DESIGN DETAILS	Page: 9
-------------------	-----------	---	------------

<input type="checkbox"/> Units Listed	<input type="checkbox"/> Numbers Checked	<input type="checkbox"/> Sources Referenced	<input type="checkbox"/> Inputs Listed
---------------------------------------	--	---	--

Item	Design Title: <u>Crush Passageway Design:</u>	Chk
------	---	-----

DESIGN CALCULATIONS:

Uprights spaced  $\approx 1,5m$  ctc (Animal length)  
To ~~avoid~~ <sup>reflect</sup> construction costs (Vowles and Holier) (1982)

Design Analysis

In this scenario the three main action driving aspects would be the:

- ①  $F_c$  - Force reaction resolution of the  $W_c$  cattle weight and
- ② The turning moment produced by the concrete footing  $M_c$  where the upright is placed
- ③  $W_w$  the crush weight.

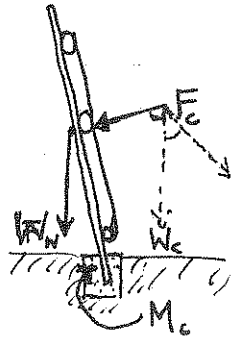

Assumptions:

From item 5(b) where the crush is 400mm wide at bottom and 900mm at top of wall translate to the <sup>design</sup> below

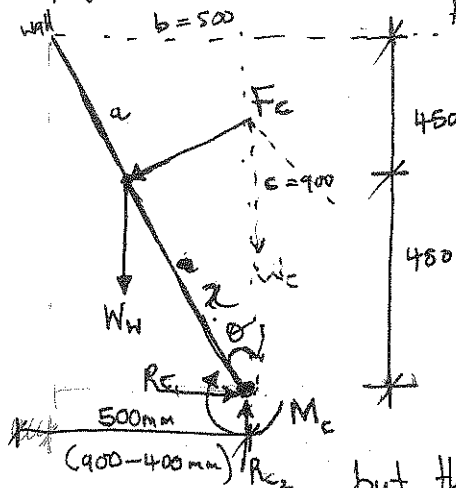

Assuming cattle reaction sidewall force is acting through centre of wall

Using pythagoras to obtain @

$$a^2 = b^2 + c^2$$

$$a^2 = (500)^2 + (900)^2$$

$$a^2 = 250000 + 810000$$

$$a^2 = 1060000 \quad a = \sqrt{1060000}$$

$$\therefore a = 1029,56 \text{ mm} \approx 1,03 \text{ m}$$

but the required unknown distance  $x = \frac{1}{2} a$

Continued to Page 10

To page: 10

Designed By: TJ MUTENJE	Date: 02/09/2010	Checked By:	Date:
----------------------------	---------------------	-------------	-------



File AI04- Box SHAPED CRUSH	Project Title: Research and Development of an RFID controlled cattle handling technology system prototype	Date 02 Sept 2010
--------------------------------	--	----------------------

By: TJ Mutenje	Reviewed:	Subject: BOX SHAPED CRUSH DESIGN DETAILS	Page: 11
-------------------	-----------	---	-------------

Units Listed    
 Numbers Checked    
 Sources Referenced    
 Inputs Listed

Item	<p>Design Title: Continued from page 10  <math>\therefore r = 514,78 \text{ mm} \approx 0,515 \text{ m}</math></p> <p>⊕ Assuming an average cow <sup>mass</sup> of 400 kg     Using <math>g = 10 \text{ kN/kg}</math> <math>\text{m/s}^2</math>.</p> <p style="margin-left: 40px;">Cow Weight = <math>400 * 10</math>  <math>= 4000 \text{ N} \approx 4 \text{ kN}</math></p> <p>Using Tan rule</p> $\tan \theta = \frac{\text{OH}}{A} = \frac{500}{900} = 0,5555$ $\therefore \theta = \tan^{-1}(0,5555) = 29,05^\circ \approx 30^\circ$ <p>Resolving for the <math>F_c = W_c \sin \theta</math>  <math>= 4000 \sin 30^\circ</math>  <math>= 2000 \text{ N} \approx 2 \text{ kN}</math></p> <p>⊗ Assuming a cattle <sup>height</sup> of 1,3-1,6 m long <sup>t</sup> fitting in a 2 planted poles space with solid panel. Assuming use of <del>black</del> <sup>galvanised</sup> pipe of <math>\phi 100</math> for planted and <math>\phi 50</math> mm strands</p> <p>Wall weight = Weight of pipes + Weight of solid panel  <math>= \text{Grade C350 (light weight pipes)} + (1,1 \text{ m} * 1,6 \text{ m} * 2 \text{ mm})</math>  <math>= [(100^{\text{XL}} \text{ DN}) \text{ pipes} * (1,1 + 0,6)] @ 8,477 \text{ kg/m} + [(50^{\text{XL}} \text{ DN}) \text{ pipes} * 4,5]</math>  <math>@ 3,399 \text{ kg/m} + 1,76 \text{ m}^2 @ 16 \text{ kg/m}^2) * 10</math></p> <p>Wall Weight = <math>(15,26 + 15,29 + 28,16) * 10</math>  <math>= 58,71 \text{ kg} * 10 \text{ N/kg}</math>  <math>= 587 \text{ N} \approx 0,587 \text{ kN}</math></p> <p style="text-align: center;">To page 12 .</p>	Chk
	To page: 12	

Designed By: T J MUTENJE	Date: 02/09/2010	Checked By:	Date:
-----------------------------	---------------------	-------------	-------



File AI04- Box SHAPED CRUSH	Project Title: Research and Development of an RFID controlled cattle handling technology system prototype	Date 02 SEPT 2010
-----------------------------------	---	----------------------

By: T J Mutenje	Reviewed:	Subject: Box SHAPED CRUSH DESIGN	Page: 12
--------------------	-----------	-------------------------------------	-------------

<input type="checkbox"/> Units Listed	<input type="checkbox"/> Numbers Checked	<input type="checkbox"/> Sources Referenced	<input type="checkbox"/> Inputs Listed
---------------------------------------	--	---	--

Item	Design Title:	Chk
	<p>From page 11</p> <p>Taking <math>\sum \vec{M} = M_c - (587 * 0,5) - (2000 * 0,515) = 0</math></p> <p>For stability assumed</p> $\sum \vec{M} = \vec{M}$ $\Rightarrow M_c - 29,35 - 1030 = 0$ $\therefore M_c = 1030 + 29,35$ $M_c = 1059,35$ <p><math>\therefore</math> Moments @ z in the positive direction of <math>M_c</math> indicated = <u>1059,35 kNm</u></p> <p>(*) To check whether the system is stable and balanced</p> <p>We take moments about B to take into account the effects of the concrete footing</p> <p>taking into consideration of the 400*400*600mm concrete footing of 20MPa mix @ 300kg/m<sup>3</sup> (SABS (2010)) ref</p> <p>Volume of footing = <math>0,4 * 0,4 * 0,6</math> = <u>0,096 m<sup>3</sup></u> - - - - - volume of footing concrete.</p> <p>Weight of concrete footing = <math>300 \text{ kg} * 0,096 \text{ m}^3 * 10</math> = <u>288 N</u></p> <p>Continued to page 13</p>	
		To page: 13

Designed By: T J Mutenje	Date: 02/09/2010	Checked By:	Date:
-----------------------------	---------------------	-------------	-------

File: AI04-BOX SHAPED CRUSH  
 Project Title: Research and Development of an RFID controlled cattle handling technology system prototype  
 Date: 02 SEPT 2010

By: T J MUTENJE  
 Reviewed:  
 Subject: BOX SHAPED CRUSH DESIGN DETAILS  
 Page: 13

Units Listed     Numbers Checked     Sources Referenced     Inputs Listed

Item      Design Title:      Chk

Continued from page 12.

Assuming a stable structure if we take moments about B  $M_c$  would balance and equal  $W_c$  moments'

CHECK // = for balance

$\sum M_B = 0$

$M_c - (288 * 0,5)$  should be equal to 0 (zero)

$M_c - 144 \neq 0$

$M_c \neq 144 \text{ Nm}$       thus structure fail / not stable

Conclusion: unstable

Recommendation: Investigate other designs to stabilise

Suggestion 1: Increase the concrete footing dimensions as illustrated below.  
 Good mix concrete of 30MPa @ 500kg/m<sup>3</sup> bonds and operate as one Unit. (SABS (2010)): (ref)

For stability maintaining  $Y$  constant @ 600mm and increase  $x$  could increase the  $W_c$  & balance  $M_c$

For Balance  $M_c$  must be equal to moments produced by footing

$\therefore M_c = \text{Mass of concrete} * g * 0,6 \text{ m}$   
 $1060 = (0,4 * 0,6 * x) * 500 * 10 * 0,6 \text{ m}$

continued to page 14 → To page: 14

Designed By: T J MUTENJE      Date: 02/09/2010      Checked By:      Date:



File AI04- Box SHAPED CRUSH	Project Title: Research and Development of an RFID controlled cattle handling technology system prototype	Date 02 SEPT 2010
--------------------------------	--	----------------------

By: T.J. Mutenje	Reviewed:	Subject: CATTLE Box SHAPED CRUSH DESIGN	Page: 14
---------------------	-----------	--	-------------

Units Listed     Numbers Checked     Sources Referenced     Inputs Listed

Item	<p>Design Title: Continued from page 13</p> <p>In order for <math>\sum M</math> to balance <math>\sum M</math> then  <math>M_c</math> must be equal to <math>= (0,4 * 0,6 * x) * 500 * 10 * 0,6 m</math>          (volume) * Mass/kg * g * Arm</p> <p><math>\therefore 1060 = 0,24 x * 3000</math>  <math>\Rightarrow 1060 = 720 x</math></p> <p>Solve for <math>x</math>      <math>\frac{720 x}{720} = \frac{1060}{720}</math></p> <p><math>\therefore x \approx 1,4722 \approx 1,5 m.</math></p> <p>Factor of safety = <math>\frac{\text{Material Strength}}{\text{Design load.}}</math>      (SABS 2010) (ref)</p> <p>* Considering vibration levels, deflection, strength, stability, buckling twisting and collapse</p> <p>Factor of safety (Design &amp; Materials) = <math>\frac{\text{Combined Material load strength}}{\text{Design load at max}}</math></p> <p><math>= \frac{5066,666}{4000}</math>      <math>\begin{cases} (3500) = 3506,5 N \\ \text{Concrete Structure} - 30 MPa \text{ on} \\ \text{surface area applicable} \\ \text{from above calculated} \\ x \text{ value } 1,17 * 10^{-4} \\ \text{Steel structure } \approx 1560,156 \\ \text{From balancing off} \end{cases}</math></p> <p>* Assuming cattle <del>lean</del> <sup>lean</sup> totally on one wall</p> <p><math>\therefore</math> Factor of safety = <math>\frac{5066,666}{4000} = 1,2667 \approx 1,3</math></p>	Chk
Continued to Page 15 $\longrightarrow$		To page: 15

Designed By: T J MUTENJE	Date: 02/09/2010	Checked By:	Date:
-----------------------------	---------------------	-------------	-------



File AI04-Box SHAPED CRUSH	Project Title: Research and Development of an RFID controlled cattle handling technology system prototype	Date 02 SEPT 2010
----------------------------------	---	----------------------

By: TJ Mutenje	Reviewed:	Subject: CATTLE BOX SHAPED CRUSH DESIGN DETAILS	Page: 15
-------------------	-----------	--	-------------

Units Listed     Numbers Checked     Sources Referenced     Inputs Listed

Item	Design Title: From page 14 continued	Chk
------	---	-----

Design Review

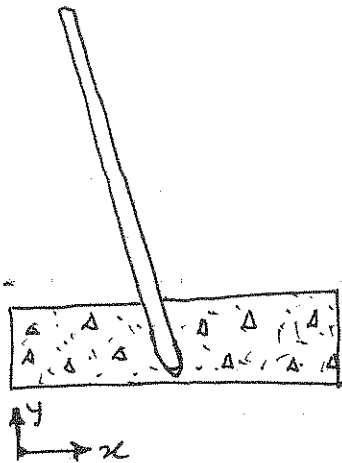

From before  $\alpha$  has been determined as:  
 $\alpha = 1,5$  before design factor

Design Concrete length for stability

$$\begin{aligned} \alpha_{final} &= \alpha * \text{design factor} \\ &= 1,5 * 1,3 \text{ (Over approximate)} \\ &= 1,95 \approx 1,9 \end{aligned}$$

Final Concrete footing length

$$\alpha_{final} = 1,9 \text{ m} \approx 1900 \text{ mm}$$

(\*)

Scenerio 2

Since the walls are symmetric about centre of passage/alley the updated design conforms to the below

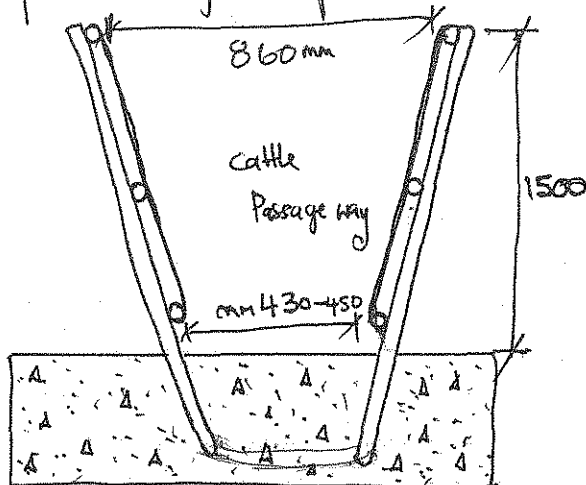

(\*) CHECK FOR STABILITY OF WALLS

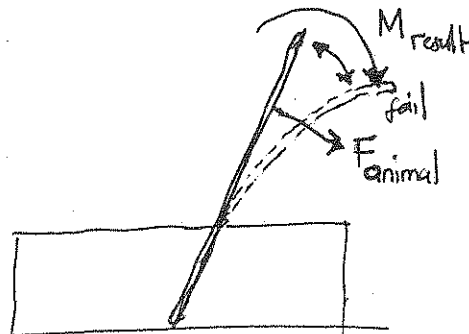

Continued to page 16 → To page: 16

Designed By: T J MUTENJE	Date: 02/07/2010	Checked By:	Date:
-----------------------------	---------------------	-------------	-------



File <b>AI04- Box SHAPED CRUSH</b>	Project Title: Research and Development of an RFID controlled cattle handling technology system prototype	Date 02 Sept 2010
---------------------------------------	--	----------------------

By: TJ Mutenje	Reviewed:	Subject: CATTLE BOX SHAPED CRUSH DESIGN DETAILS	Page: 16
-------------------	-----------	--	-------------

Units Listed    
 Numbers Checked    
 Sources Referenced    
 Inputs Listed

Item	Design Title: from page 15 continued	Chk
------	--------------------------------------	-----

⊗ In order to reduce turning moments there would be a need to share the load between both walls by joining the planted posts as below

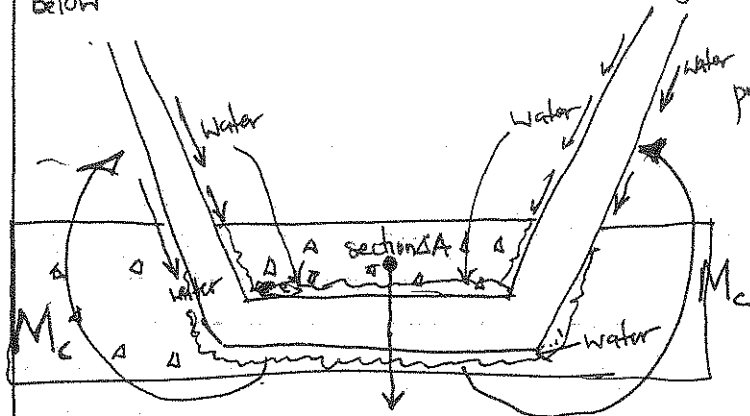

section A weight presses down on the

$M_c$  counters the turning moment caused by the lower level forces.

⊗ SABS (2010) recommends that:

⊗ Steel tubing planted in concrete must cut through concrete in order to deposit the excess water down to ground and not for the water to remain within concrete (oxidation might result) thus weakening concrete's grip

⊗ Recommendation:  
Extend the joined pipes/structure to below the concrete and check for pressures exerted on the structure.

Solution

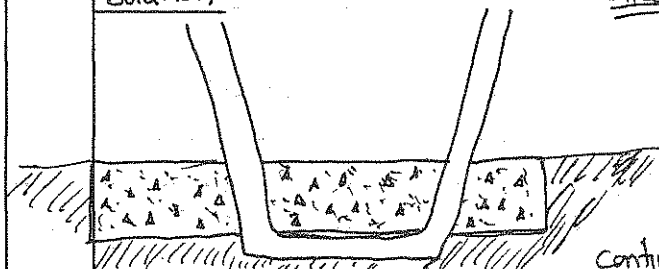

Check: The buried pipe (chosen) to sustain the concrete's weight and not deform

Total Concrete as a Unit = ~~(1.9 \* 0.6 \* 0.4)~~ \*  
= Weight \* distribution area  
= (1.9 \* 0.6 \* 0.4) \* 500 \* 10 = 2280N

continued to page 17     To page: 17

Designed By: T J MUTENJE	Date: 02/09/2010	Checked By:	Date:
-----------------------------	---------------------	-------------	-------

File AI04-Box SHAPED CRUSH	Project Title: Research and Development of an RFID controlled cattle handling technology system prototype	Date 02 SEPT 2010
----------------------------------	---	----------------------

By: TJ Mutenje	Reviewed:	Subject: CATTLE BOX SHAPED CRUSH DESIGN	Page: 17
-------------------	-----------	--	-------------

<input type="checkbox"/> Units Listed	<input type="checkbox"/> Numbers Checked	<input type="checkbox"/> Sources Referenced	<input type="checkbox"/> Inputs Listed
---------------------------------------	--	---	--

Item	Design Title: Continued from Page 16	Chk
------	--------------------------------------	-----

Concrete Weight = 2280 N  
distributed across 400 mm

∴ Considering Concrete as a uniformly distributed load implies

$$W_c = \frac{\text{Total Weight}}{\text{distribution distance}} = \frac{2280 \text{ N}}{0,4 \text{ m}} = 5700 \text{ N/m.}$$

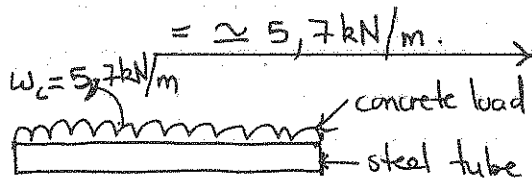

W<sub>c</sub> = uniformly distributed  
concrete load as  
illustrated.

⊛ Selection of tubing sizes from ISO steel tube standards  
Recommended size to sustain W<sub>c</sub> \* Safety factor (obtained from <sup>before</sup>)

$$\begin{aligned} \text{Size to sustain} &= 5,7 \text{ kN/m} * 1,3 \\ &= \underline{7,41 \text{ kN/m}} \end{aligned}$$

SABS 657/1 (hot rolled tubes round tubes)

Above specifications translate to  
SABS 657 Ø101,60m structural round tube of wall  
thickness 3-3,5mm and weight of 8,469 kg/m.

Carried Project Specification: Ref PS1e  
to Use SABS 657 Ø101,60m structural round tube of wall  
PS1e thickness 3-3,5mm, 8,469 kg/m for all planted posts and wall  
PS1e support boxes.

Continued on page 18 → To page: 18

Designed By: T J MUTENJE	Date: 02/09/2010	Checked By:	Date:
-----------------------------	---------------------	-------------	-------



File: AI04-Box SHAPED CRUSH  
 Project Title: Research and Development of an RFID controlled cattle handling technology system prototype  
 Date: 02 SEPT 2010

By: T J Mutenje  
 Reviewed: Subject: CATTLE BOX SHAPED CRUSH DESIGN  
 Page: 19

Units Listed  Numbers Checked  Sources Referenced  Inputs Listed

Item Design Title: Continued from page 18

Design Check.

Assumming we use the same SABS 657  $\phi$  101,60mm tubing with a maximum allowable force of \_\_\_\_\_

check

Considering the effects of taking Moments about M

$$\sum M = 0$$

$$-M_c + \overset{(2293,5)}{\text{Combined force}} * 0,515 - F_{\text{crush}} * 1,5 = 0$$

$$\Rightarrow -M_c + 1181,15 - F_{\text{crush}} * 1,5 = 0$$

$$\Rightarrow 1,5 F_{\text{crush}} = -1059,35 + 1181,15$$

(From page 15)

$$\Rightarrow 1,5 F_{\text{crush}} = 121,802$$

$$\Rightarrow F_{\text{crush}} = \frac{121,802}{1,5} = 81,20 \text{ N required}$$

check Required Force from box crush =  $F_{\text{crush}} * \text{factor} = 81,20 * 1,3 = 105,56 \text{ N}$

Force allowable for SABS 657  $\phi$  101,60 (Resolved)  $\gg F_{\text{crush}} \text{ required}$

thus stable  $\checkmark$  GOOD

To page: 20

Designed By: T J MUTENJE  
 Date: \_\_\_\_\_  
 Checked By: \_\_\_\_\_  
 Date: \_\_\_\_\_

File AI04- Box SHAPED CRUSH	Project Title: Research and Development of an RFID controlled cattle handling technology system prototype	Date 02 Sept 2010
--------------------------------	--	----------------------

By: T J Mutenje	Reviewed:	Subject: CATTLE BOX SHAPED CRUSH DESIGN	Page: 20
--------------------	-----------	--	-------------

Units Listed   
 Numbers Checked   
 Sources Referenced   
 Inputs Listed

Item	Design Title: Continued from page 19	Chk
------	--------------------------------------	-----

Design Review

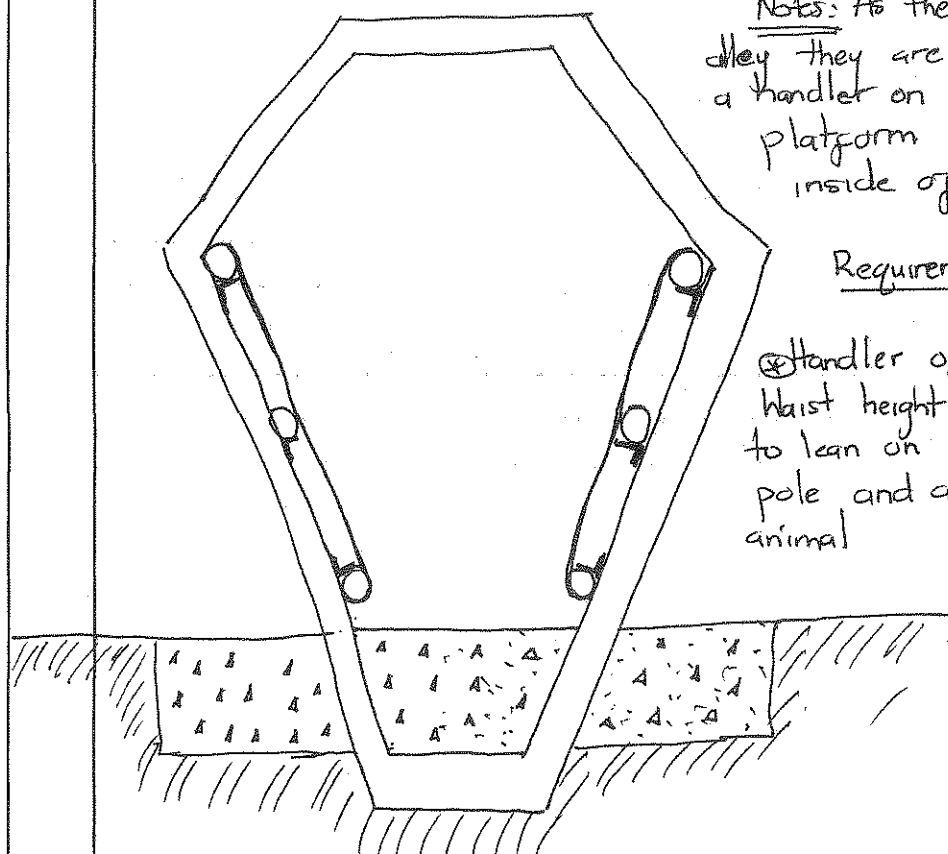

Notes: As the cattle follow the alley they are driven by a handler on a raised platform in the inside of the curve.

Requirements:

⊗ handler of an average waist height of 1,2-1,4m to lean on top strand pole and attend to the animal

To fulfill the design requirements

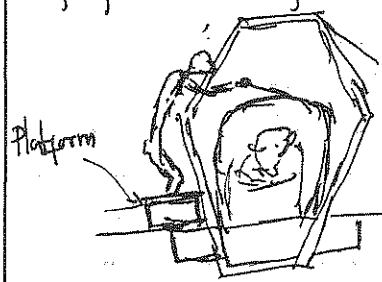

For the handler of waist height of between 1,1-1,3 m a raised catwalk is required.

Continued to page 21

To page: 21

Designed By: T J MUTENJE	Date: 02 Sept 2010	Checked By:	Date:
-----------------------------	-----------------------	-------------	-------



File AI04- Box SHAPED CRUSH	Project Title: Research and Development of an RFID controlled cattle handling technology system prototype	Date 02 SEPT 2010
--------------------------------	--	----------------------

By: T J Mutenje	Reviewed:	Subject: CATTLE BOX SHAPED CRUSH ASSEMBLY	Page: 21
--------------------	-----------	--	-------------

Units Listed     Numbers Checked     Sources Referenced     Inputs Listed

Item	Design Title: Continued design from page 20	Chk
------	---	-----

Design Calculation

Catwalk dimensions calculations

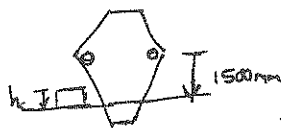

in order to accommodate waist height at the top barrier catwalk height  $h_c = \text{Rail height} - (\approx 1,2)$

$$h_{\text{catwalk}} = 1500 - 1100 \text{ mm} = 400 \text{ mm} \rightarrow$$

\* For ergonomics reasons allowance for a comfortable posture would be to allow two (2) feet <sup>600mm</sup> length as the catwalk width.

On average two (2) feet width  $\approx 600 - 650 \text{ mm}$  range

(Metric!)  
2 (304,8)  
610 mm

\* Material Selection and Structural design

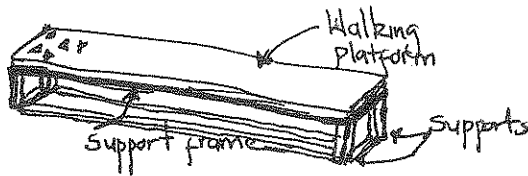

Resolution

- ① Walking platform
- Use expanded metal instead of pine plank for longer life corrosion reasons

- ② Use square tubing for support frame and,
- ③ Use square tubing for supports

Assumption

Assuming that one average person <sup>(80kg)</sup> stands on the <sup>(60kg)</sup> 1,5m  $\approx 1500 \text{ mm}$  portion of crush platform supported by expanded metal, support frame and upright supports.

Free body diagram:

\* continued on page 22

To page: 22

Designed By: T J MUTENJE	Date: 02/09/2010	Checked By:	Date:
-----------------------------	---------------------	-------------	-------



File AI04- Box SHAPED CRUSH	Project Title: Research and Development of an RFID controlled cattle handling technology system prototype	Date 02 SEPT 2010
-----------------------------------	---	----------------------

By: TJ Mutenje	Reviewed:	Subject: CATTLE CRUSH DESIGN DETAILS	Page: 22
-------------------	-----------	---	-------------

Units Listed     Numbers Checked     Sources Referenced     Inputs Listed

Item Design Title: Continued from page 21 (expanded metal NEM 318F)  
Catwalk Free body diagram

$W_e$  expanded metal as a uniformly distributed load.

From SABS/SANS 190-1:2000 and 190-2:2008 Expanded Metal of  $4,5 \text{ kg/m}^2$   
(SWM-15, LWM-40, STRAND 3,0mm & 1,6mm width & thickness respectively)

Expanded metal area  $A_E = L * \text{Width} = 1500 * 600 = 0,9 \text{ m}^2$

Total weight = Weight/ $\text{m}^2$  \* Total area  
 $= 4,5 \text{ kg/m}^2 * 0,9 \text{ m}^2 = 4,05 \text{ kg}$

Given a total length of Expanded metal for section to be 1500mm

$\therefore W_e = \frac{\text{Total Weight}}{\text{Expanded metal length}} = \frac{4,05 * 10}{1500 \text{ mm} / 1,5} = 27 \text{ N/m}$

Taking Moments about A  $(M_A)$   $W_e * 1,5 * 0,75 - R_B * 1,5 = 0$  assuming stability

$\Rightarrow 1,5 R_B = 1,125 W_e \quad \therefore R_B = \frac{1,125 W_e}{1,5} = 20,25 \text{ N}$

$\uparrow R \quad R_A + R_B - W_e * 1,5 = 0$   
 $\therefore R_A = -R_B + W_e * 1,5 = 1,5 W_e - R_B = 20,25 \text{ N}$  check

Reactions @ A and B are supported by 2 supports thus selection of support sizes that have an allowable compressional strength of  $\frac{R_A}{2}$  or  $\frac{R_B}{2}$  ✓



use X in  
stead of \*

Continued to page 23 To page: 23

Designed By: T J MUTENJE	Date: 2/09/2010	Checked By:	Date:
-----------------------------	--------------------	-------------	-------

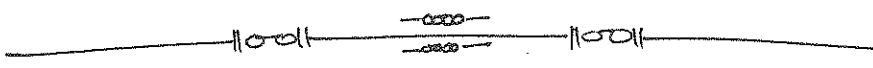

Weight forces of attendant? 80kgf!

File <b>AI04-Box SHAPED CRUSH</b>		Project Title: Research and Development of an RFID controlled cattle handling technology system prototype		Date 02 SEPT 2010
By: TJ Mutenje	Reviewed:	Subject: CATTLE CRUSH DESIGN DETAILS		Page: 23
<input type="checkbox"/> Units Listed <input type="checkbox"/> Numbers Checked <input type="checkbox"/> Sources Referenced <input type="checkbox"/> Inputs Listed				
Item	Design Title: Continued from page 22 Support tubes selection From page 22 each support to carry $F_{\text{support}} = \left(\frac{R_A \text{ or } R_B}{2}\right) \times \text{factor}$ $F_{\text{support}} = \left(\frac{R_A}{2}\right) \times 1,3 = 0,65 R_A = \underline{13,16 N}$ From SABS 1200+1990 Selection tables this translates to 4 Supports of 50*50mm square tubing			Chk
Carried PS1f	Project Specification: Ref PS1f <del>Use SABS 657 <math>\phi 101,60</math> (Standard, SWM-15; LWM-4,0; of 4,5kg/m<sup>2</sup>)</del> Use SABS 190-142 standard expanded metal for all catwalks to supported by 38*38 mm square tubing support frames on 50*50mm square tubing (4) four supports per each 1,5m portion of side crush to aid ergonomically friendly management practice.			
				
Continued to page 24				
Designed By: T J MUTENJE		Date: 02/09/2010	Checked By:	Date:
		Agricultural Research Council - Institute for Agricultural Engineering. Agricultural Infrastructure and Engineering Structures Division, Design & Calc, Modeling, Design & Drafting P Bag X519, Silverton, Pretoria, 0127 +27(0) 12 842 4000 www.arc.agric.za		



File AI04-Box SHAPED CRUSH	Project Title: Research and Development of an RFID controlled cattle handling technology system prototype	Date 03 Sept 2010
-------------------------------	--	----------------------

By: TJ Mutenje	Reviewed:	Subject: FINAL DESIGN : CATTLE CRUSH	Page: 25
-------------------	-----------	---	-------------

Units Listed     Numbers Checked     Sources Referenced     Inputs Listed

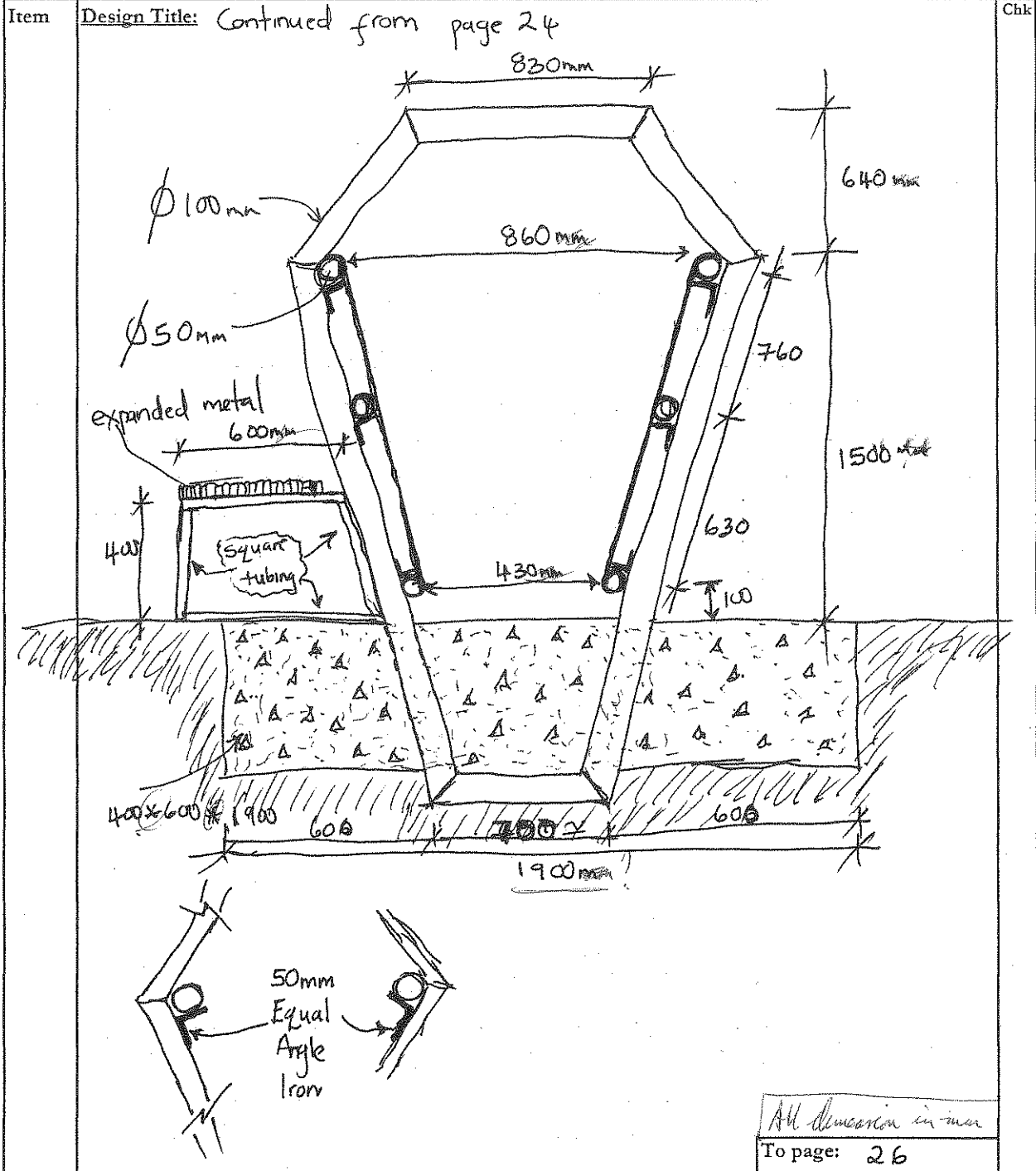

Designed By: T J MUTENJE	Date: 03/09/2010	Checked By:	Date:
-----------------------------	---------------------	-------------	-------

File <b>AI04- Box SHAPED CRUSH</b>	Project Title: Research and Development of an RFID controlled cattle handling technology system prototype	Date 03 SEPT 2010
---------------------------------------	--	----------------------

By: TJ Mutenje	Reviewed:	Subject: <b>FINAL DESIGN : CATTLE CRUSH</b>	Page: 24
-------------------	-----------	--	-------------

Units Listed    
 Numbers Checked    
 Sources Referenced    
 Inputs Listed

Item	Design Title: Finalised views of the Box Shaped Crush	Chk:
------	---	------

SIDE VIEW  
=||=||=||=  
AT WALK SIDE

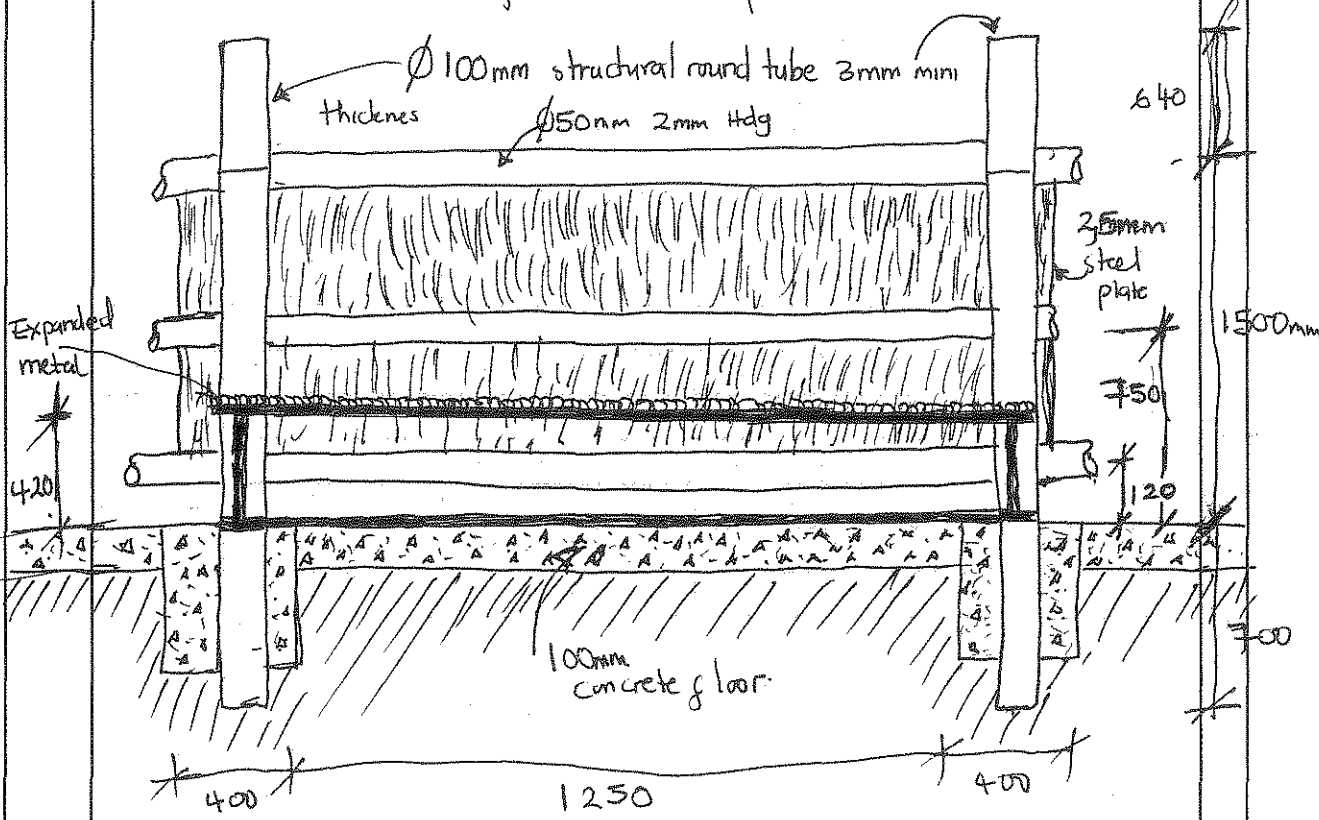

PLAN VIEW

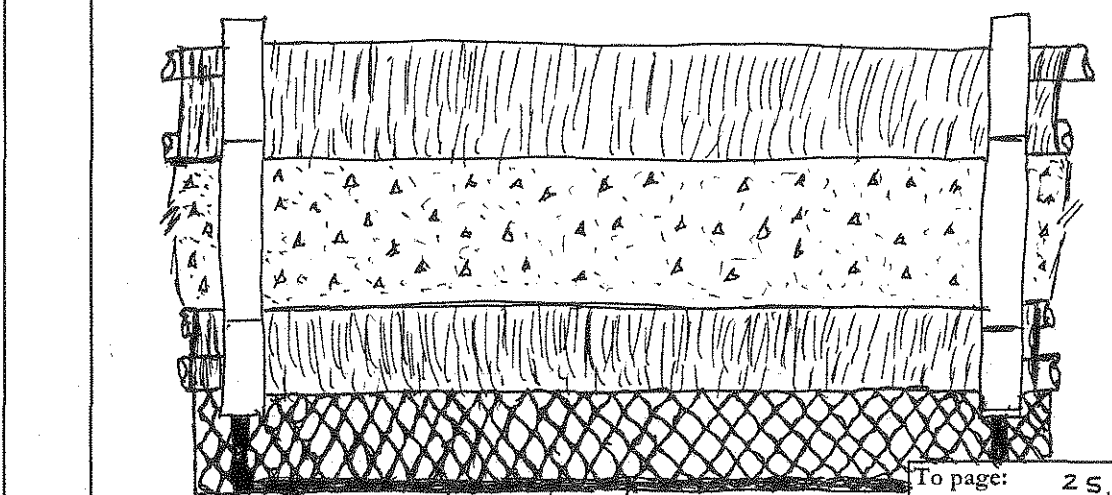

To page: 25.

Designed By: <b>T J MUTENJE</b>	Date: 03 Sept 2010	Checked By:	Date:
------------------------------------	-----------------------	-------------	-------

File AI04-Box SHAPED CRUSH	Project Title: Research and Development of an RFID controlled cattle handling technology system prototype	Date 03 SEPT 2010
----------------------------------	---	----------------------

By: TJ Mutenje	Reviewed:	Subject: BOX SHAPED CRUSH ASSEMBLY DESIGN	Page: 26
-------------------	-----------	--	-------------

Units Listed     Numbers Checked     Sources Referenced     Inputs Listed

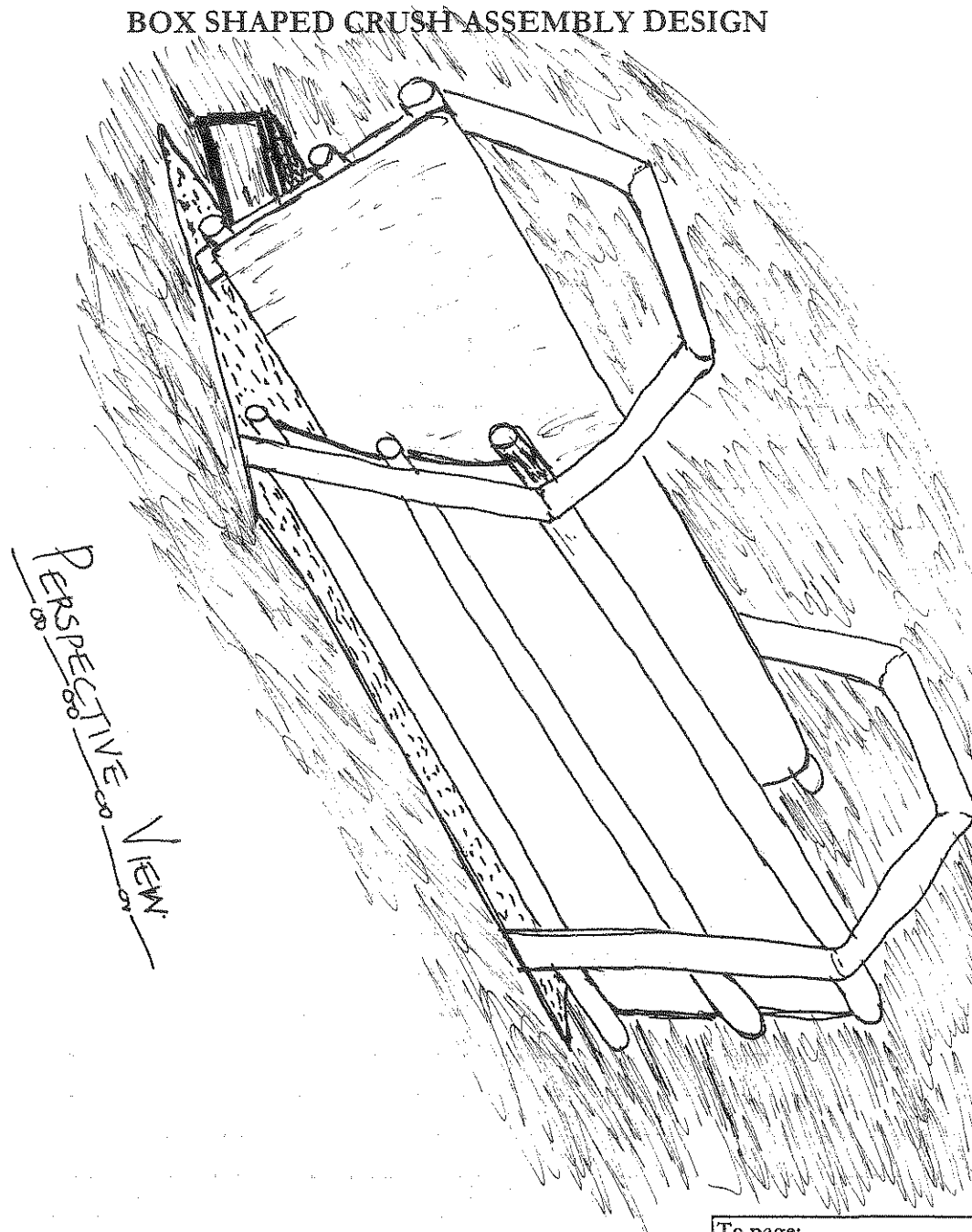
Item	Design Title: <b>BOX SHAPED CRUSH ASSEMBLY DESIGN</b>	Chk
 <p>PERSPECTIVE VIEW</p>		
		To page:

Designed By: TJ MUTENJE	Date: 03/09/2010	Checked By:	Date:
----------------------------	---------------------	-------------	-------



File <b>AI04-Cattle Flow Control System</b>		Project Title: Research and Development of an RFID controlled cattle handling technology system prototype		Date <b>17 September 2010</b>
By: Tendai Justin Mutenje	Reviewed:	Subject: CATTLE FLOW CONTROL SYSTEM		Page: COVER PAGE
<input type="checkbox"/> Units Listed		<input type="checkbox"/> Numbers Checked		<input type="checkbox"/> Sources Referenced
				<input type="checkbox"/> Inputs Listed
Item	Design Title:			Chk
<p><b>DESIGN NOTES</b></p> <p><b>FOR THE</b></p> <p><b>CATTLE FLOW CONTROL SYSTEM</b></p> <p><b>DOUBLE SPLIT GATE</b></p> <p><b>12 PAGES</b></p>				
				To page: 1
Designed By: Tendai Justin MUTENJE		Date: 17 Sept 2010	Checked By:	
			Date:	
		Agricultural Research Council - Institute for Agricultural Engineering. Agricultural Infrastructure and Engineering Structures Division, Design & Cales, Modeling, Design & Drafting P Bag X519, Silverton, Pretoria, 0127 +27(0) 12 842 4000 www.arc.agric.za		

File AI04- CATTLE FLOW CONTROL SYSTEM	Project Title: Research and Development of an RFID controlled cattle handling technology system prototype	Date 17 Sept 2010
--	--	----------------------

By: T J MUTENJE	Reviewed:	Subject: CATTLE FLOW CONTROL SYSTEM	Page: 1
-----------------	-----------	--	------------

Units Listed    
 Numbers Checked    
 Sources Referenced    
 Inputs Listed

Item	Design Title: <u>CATTLE FLOW CONTROL SYSTEM.</u>  Design Problems (Notes 2) <span style="float: right;">⊛ - Critical factor</span>  ① Uncontrollable cattle flow towards the weighing identification system ⊛ ② Stressfull operations (opening and closing of gates manually) ⊛ ③ Gates operation noisy. ④ Injuries on animal on closing of gates late. ⑤ Flow speed regulation. and individual animal control problems	Chk
Solutions to design problem go to page 2 →		To page: 2

Designed By: T J Mutenje	Date: 17/09/2010	Checked By:	Date:
-----------------------------	---------------------	-------------	-------

File <b>AI04-CATTLE FLOW CONTROL SYSTEM</b>		Project Title: Research and Development of an RFID controlled cattle handling technology system prototype	Date 17 SEPT 2010
By: T J Mutenje	Reviewed:	Subject: <b>CATTLE FLOW CONTROL SYSTEM</b>	Page: 2

Units Listed     
 Numbers Checked     
 Sources Referenced     
 Inputs Listed

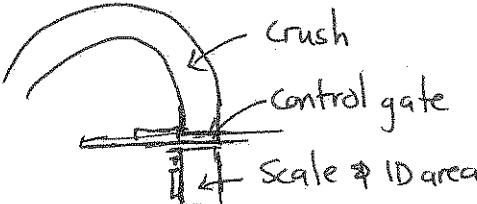
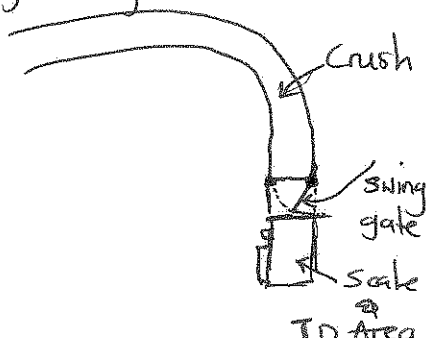
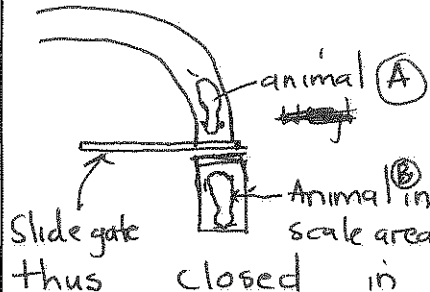
Item	<p>Design Title: → From page 1</p> <p><u>DESIGN SOLUTIONS</u></p> <p>① <u>CATTLE Control</u></p> <p><u>Grandin (2003) (ref)</u>  In order to have better control of animals from crush to scale there is need of flow control gates/system as below</p> <div style="display: flex; justify-content: space-around;"> <div style="text-align: center;">  <p>Crush Control gate Scale &amp; ID area.</p> </div> <div style="text-align: center;">  <p>Crush Swing gate Scale &amp; ID Area</p> </div> </div> <p style="text-align: center;">or</p> <p><u>CISR (2004) (ref)</u>  There is a problem in having a single control gate along the crush passage as different/a range of practices must be undertaken whilst control is required thus 1 gate won't serve the purpose as illustrated below. Notes: ① Animal (A) must have an independent control system different to that controls (B) ② Sliding gate takes long to come back to a closing position ~ 2.5s on average ③ Animal moves an average 1m/sec thus closed in between.</p> <div style="display: flex; align-items: center;">  <div style="margin-left: 20px;"> <p>animal (A)</p> <p>Slide gate</p> <p>Animal (B) in scale area</p> </div> </div> <p style="text-align: right;">Solution continue to page 3 →</p>	Chk
	To page: 3	

Designed By: T J Mutenje	Date: 17/09/2010	Checked By:	Date:
-----------------------------	---------------------	-------------	-------

File <b>AI04-CATTLE FLOW CONTROL SYSTEM</b>	Project Title: Research and Development of an RFID controlled cattle handling technology system prototype	Date 17 SEPT 2010
--	--	----------------------

By: <b>TJ Mutenje</b>	Reviewed:	Subject: <b>CATTLE FLOW CONTROL SYSTEM</b>	Page: <b>3</b>
--------------------------	-----------	---	-------------------

Units Listed     
 Numbers Checked     
 Sources Referenced     
 Inputs Listed

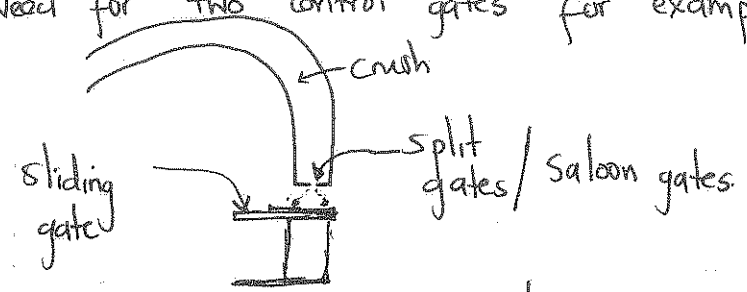
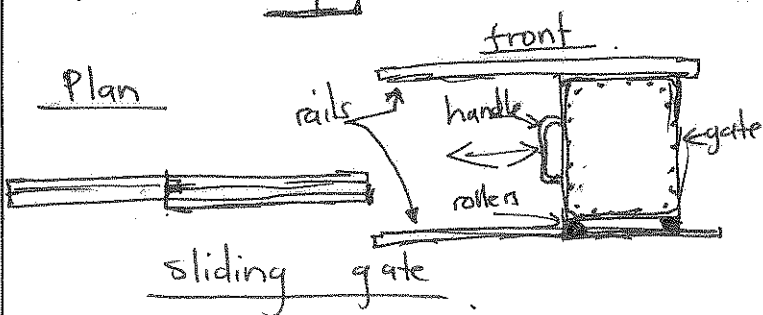
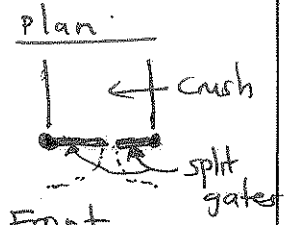
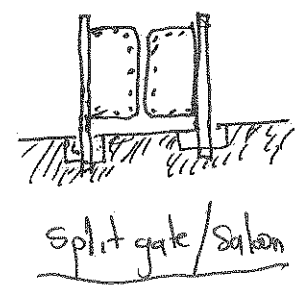
Item	Design Title:	<p>continued from page 2</p> <p><u>Owen (2004) (ref)</u> Need for two control gates for example below:</p> <div style="display: flex; justify-content: space-around;"> <div style="text-align: center;">  <p>Plan</p>  <p>sliding gate</p> </div> <div style="text-align: center;"> <p>Plan:</p>  <p>Front</p>  <p>Split gate/Saloon</p> </div> </div> <p><u>Mansholt laan (2004) (ref)</u> Need for 2 gates serving as</p> <ol style="list-style-type: none"> <li>① Access Control</li> <li>② Anti backing system</li> </ol> <p><u>CISR Workgroup (2004) ref:</u> Conclusion of two gates</p> <ol style="list-style-type: none"> <li>① Split gate - Cattle flow control</li> <li>② Sliding gate - Anti Backing system in identification and reading/weighing system.</li> </ol> <p style="text-align: center;">To page 4 →</p>	Chk
		To page: 4	

Designed By: <b>TJ Mutenje</b>	Date:	Checked By:	Date:
-----------------------------------	-------	-------------	-------

File AI04- CATTLE FLOW CONTROL	Project Title: Research and Development of an RFID controlled cattle handling technology system prototype	Date 17/09/2010
--------------------------------------	--	--------------------

By: T J MUTENJE	Reviewed:	Subject: CATTLE FLOW CONTROL SYSTEM	Page: 4
--------------------	-----------	--	------------

Units Listed     
 Numbers Checked     
 Sources Referenced     
 Inputs Listed

Item	<p>Design Title: From page 3</p> <p>② <u>Stressfull Operation of gates</u></p> <p>To ease the operations there is need to introduce a more egonomically friendly way of operations</p> <p><u>DESIGN NOTES</u></p> <p>Conceptual design - Change manual system to automated remote controlled system.</p> <p>Lewis (2010) (ref)</p> <p>Why Automate:</p> <table border="0"> <tr> <td>- task too difficult</td> <td rowspan="3">  - require too many resources</td> </tr> <tr> <td>- task time consuming</td> </tr> <tr> <td>- task too boring</td> <td>- too much exertion</td> </tr> </table> <p>Automation will make it:</p> <ul style="list-style-type: none"> <li>- Quicker</li> <li>- more acurate</li> <li>- more easily intergrated with other task</li> </ul> <p><u>Automation Types</u></p> <table border="0"> <tr> <td>Mechanical</td> <td rowspan="5">} Selected is a combination of all of the listed</td> </tr> <tr> <td>Electric</td> </tr> <tr> <td>Pneumatic</td> </tr> <tr> <td>Hydraulic</td> </tr> <tr> <td>Electronic</td> </tr> </table> <p>Design notes continues to page 5 →</p>	- task too difficult	- require too many resources	- task time consuming	- task too boring	- too much exertion	Mechanical	} Selected is a combination of all of the listed	Electric	Pneumatic	Hydraulic	Electronic	Chk
- task too difficult	- require too many resources												
- task time consuming													
- task too boring		- too much exertion											
Mechanical	} Selected is a combination of all of the listed												
Electric													
Pneumatic													
Hydraulic													
Electronic													
To page: 5													

Designed By: T J Mutenje	Date: 17/09/2010	Checked By:	Date:
-----------------------------	---------------------	-------------	-------



File <b>AI04-CATTLE FLOW CONTROL</b>	Project Title: Research and Development of an RFID controlled cattle handling technology system prototype	Date 17 SEPT 2010
---	---	----------------------

By: <b>TJ MUTENJE</b>	Reviewed:	Subject: <b>CATTLE FLOW CONTROL SYSTEM</b>	Page: <b>5</b>
---------------------------	-----------	---	-------------------

- Units Listed    
 Numbers Checked    
 Sources Referenced    
 Inputs Listed

Item	Design Title: Continued from page 4	Chk
------	--	-----

Design Notes

From Box shaped crush Design notes  
Passage  $\approx$  850mm wide  
Gate Concept

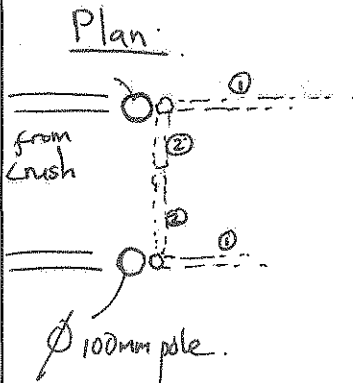

- Concept
- Gates closed @ position ② (stop flow)
  - Gates opened @ position ① (allow flow)
  - ⊛ Adapted 2 split gates

Control System

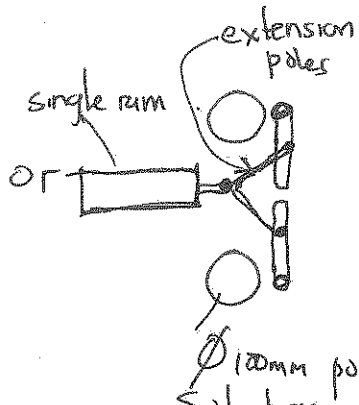
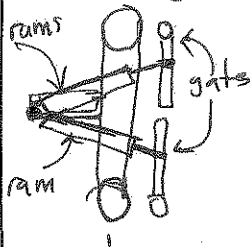

Solution 1

- More rams
- More programming
- More air control
- One may be faulty & fail other

Solution 2

- less air control
- less programming
- less air requirements
- Load on single ram
- Failure will halt entire system

⊛ Adopt solution ② →

To page: 6

Designed By: <b>TJ Mutenje</b>	Date:	Checked By:	Date:
-----------------------------------	-------	-------------	-------

File <b>AI04-CATTLE FLOW CONTROL</b>	Project Title: Research and Development of an RFID controlled cattle handling technology system prototype	Date 17 SEPT 2010
---	--	----------------------

By: <b>T J MUTENJE</b>	Reviewed:	Subject: <b>CATTLE FLOW CONTROL SYSTEM</b>	Page: <b>6</b>
----------------------------	-----------	---	-------------------

Units Listed       Numbers Checked       Sources Referenced       Inputs Listed

Item	Design Title: <b>Continued from page 5.</b>	Chk
------	---	-----

Design Notes

Advantages of Pneumatics (Compressed air operated)

- Safe, powerful, reliable and economical.
- No spark or electrical burn out
- tools and equipment components compact, lightweight & versatile

Concept

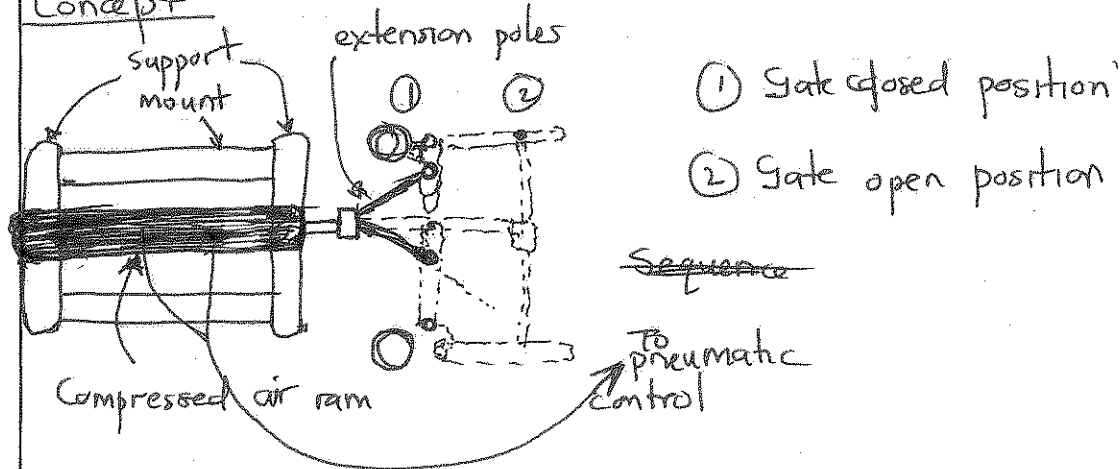

Sequence

Sequence

As cattle reach the gate system operator remotely opens the control gates through the use of a remote pneumatic control unit that opens/controls the compressed air rams.

Advantages & Concepts

- Double leaf split gates/saloon gates respond to remote control
- Each gate has a width equal to 1/2 of the width of the alley so that they close alley without interference to each other
- ⊗ Advantage of split gate is that they shut entrance quickly without trapping animal/allowing them to slip past during closure

Continued to page 7 →

To page: 7

Designed By: <b>T J Mutenje</b>	Date: 17/09/2010	Checked By:	Date:
------------------------------------	---------------------	-------------	-------



File <b>AI04-CATTLE</b> <b>FLOW CONTROL SYSTEM</b>	Project Title: Research and Development of an RFID controlled cattle handling technology system prototype	Date 17/sept/2010
--	---	----------------------

By: <b>T J MUTENJE</b>	Reviewed:	Subject: <b>CATTLE FLOW CONTROL SYSTEM</b>	Page: <b>7</b>
------------------------	-----------	---	-------------------

Units Listed   
 Numbers Checked   
 Sources Referenced   
 Inputs Listed

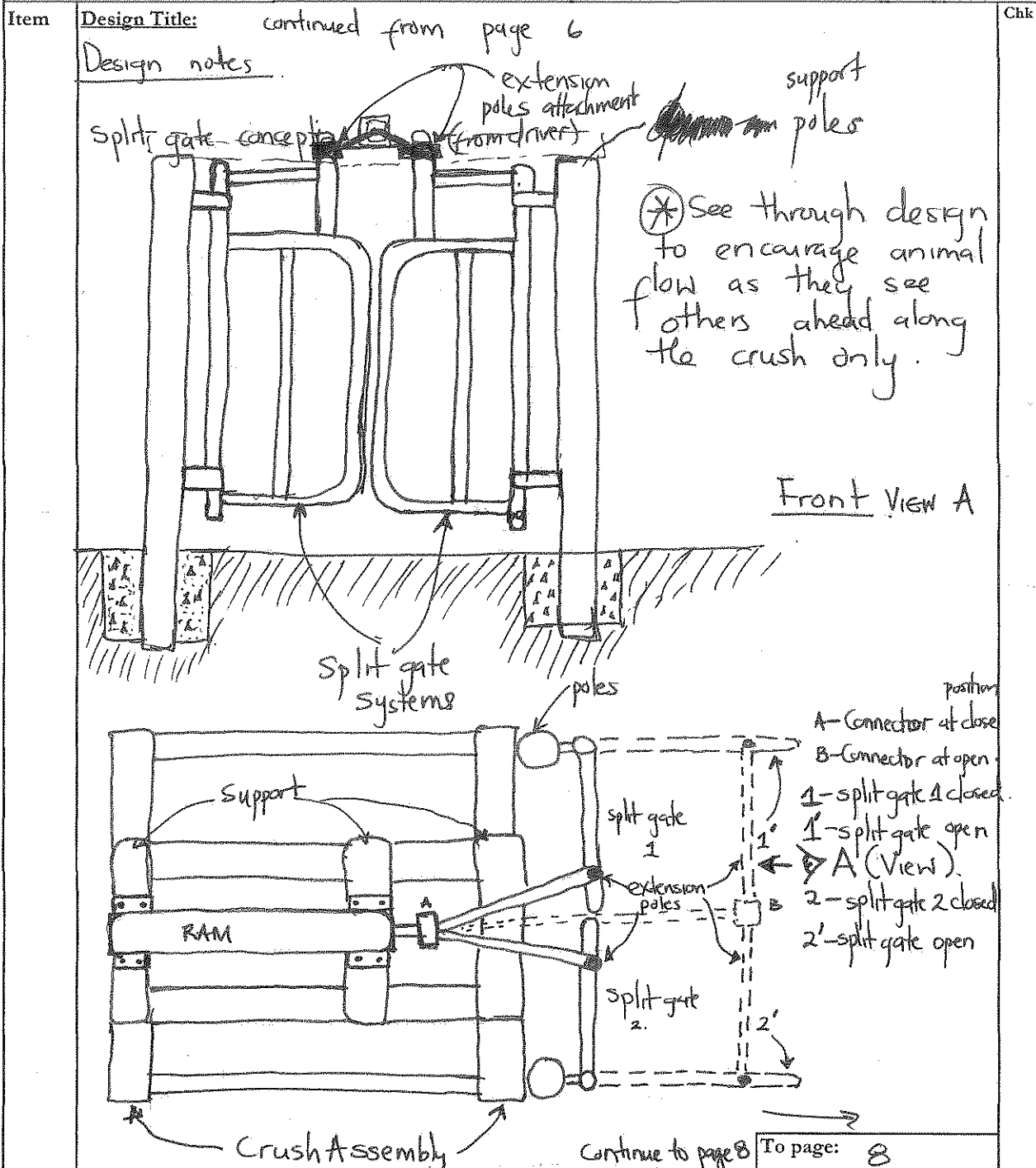

Designed By: <b>T J Mutenje</b>	Date: 17/09/2010	Checked By:	Date:
------------------------------------	---------------------	-------------	-------

File <b>AI04- CATTLE</b>	Project Title: Research and Development of an RFID controlled cattle handling technology system prototype	Date 17/Sept/2010
-----------------------------	--	----------------------

By: T J MUTENJE	Reviewed:	Subject: CATTLE FLOW CONTROL SYSTEM	Page: 8
--------------------	-----------	--	------------

Units Listed     
 Numbers Checked     
 Sources Referenced     
 Inputs Listed

Item	Design Title: continued from page 7 Design sketches continue	Chk
------	--	-----

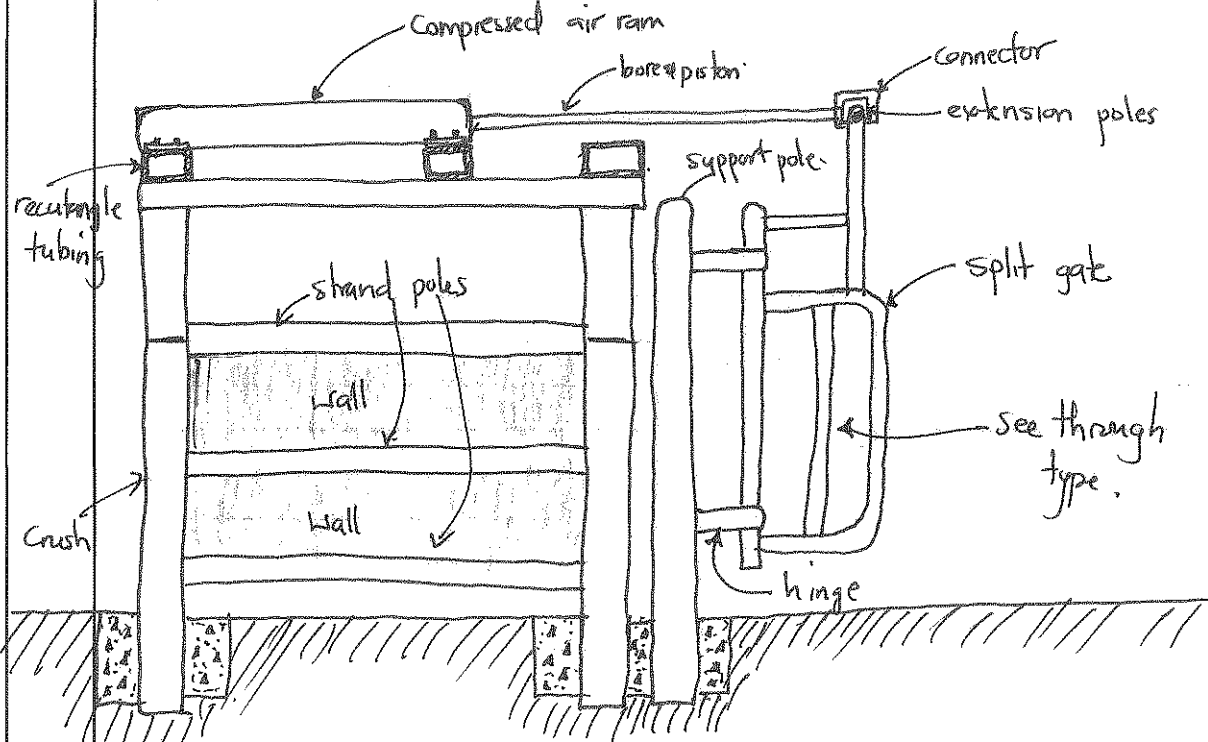

Side view

Design Data

Assuming we use ~~30~~ 50 mm round tubing for split gate  
 Assuming  $g = 10 \text{ N/kg}$   
 Gate weight = (Mass/unit mm) \* Total steel length \*  $g$   
 $= 3000 * 4940 \approx (5000) * 10$   
 $= 150 \text{ N}$   
 $\therefore$  Total gate weight = 150 N (factor of safety 1,3)

In order to support gate weight of 195 N from SABS standard \_\_\_\_\_ Choice of 2 hinges of \_\_\_\_\_ type.  
 continue to page 9  $\rightarrow$  To page: 9

Designed By: T J MUTENJE	Date: 17/09/2010	Checked By:	Date:
-----------------------------	---------------------	-------------	-------



File AI04- CATTLE FLOW CONTROL SYSTEM	Project Title: Research and Development of an RFID controlled cattle handling technology system prototype	Date 17 SEPT 2010
---	---	----------------------

By: T J MUTENJE	Reviewed:	Subject: CATTLE FLOW CONTROL SYSTEM	Page: 9
--------------------	-----------	--	------------

<input type="checkbox"/> Units Listed	<input type="checkbox"/> Numbers Checked	<input type="checkbox"/> Sources Referenced	<input type="checkbox"/> Inputs Listed
---------------------------------------	--	---	--

Item	<p><u>Design Title:</u> Continued from page 8 Assuming that the hinge has to sustain ① Weight of gate ② Impact of cattle on gate.</p> <p><u>Stopping force of Cattle</u></p> <p>Using the principle of momentum conservation.</p> $F = \frac{\Delta mv}{t} = \frac{mv_f - mu}{t}$ <p>where u = initial velocity V = final velocity t = time taken.</p> <p>Taking the worst case scenario from literature where cattle attained a speed of <math>\approx 3 \text{ m/s}</math> in a distance of <del>2</del> from rest in 2m in 1sec.</p> <p>u = 0    t = 1    Assuming a 500kg animal V = 3    m = 500</p> $\therefore F = \frac{\Delta mv}{t} = \frac{500(3-0)}{1} = 1500 \text{ N}$ <p>taking a safety factor of 1,3 <math>\therefore</math> stopping force = <math>1,500 \times 1,3</math></p> <p>Force required to stop cattle = <u>1950 N</u> →</p> <p><math>\therefore</math> Hinge and compressed air rams both must be able to stop a combined gate weight and stopping force</p> <p><math>\therefore</math> Design Force of the ramp to stop cattle and sustain gate</p> $\approx \text{Force (stop) (ow) + Force (gate)}$ $= 1950 + 195$ $= 2145 \text{ N} \quad \approx 2,2 \text{ kN}$	Chk
	To page: 10	

Designed By: T J Mutenje	Date: 17/09/2010	Checked By:	Date:
-----------------------------	---------------------	-------------	-------

File <b>AI04-CATTLE FLOW CONTROL SYSTEM</b>	Project Title: Research and Development of an RFID controlled cattle handling technology system prototype	Date 18/09/2010
--	---	--------------------

By: T J MUTENJE	Reviewed:	Subject: CATTLE FLOW CONTROL SYSTEM	Page: 10
--------------------	-----------	--	-------------

Units Listed       Numbers Checked       Sources Referenced       Inputs Listed

Item	<p><b>Design Title:</b> Continued from page 9</p> <p>Extension pipes and connection of total 420mm<sup>each</sup> length is also carried by the ramp. translate to a total weight of <math>\approx 50N</math> (in horizontal plane).</p> <p>Free body diagram of stopping force.</p> <p>Compressed air ram.</p> <p>Including a factor of safety of 1,3</p> <p>Required design force from RAM = <math>1,3 * 2,2</math>  <math>= 2,86 kN</math>  <math>\approx 3 kN</math> or <math>3000N</math> →</p> <p><u>Welding design</u></p> <p>Hinge weld</p> <p>for equilibrium</p> <p><math>\uparrow R \Rightarrow R - 200 = 0</math>  <math>\therefore R = 200N</math> →</p> <p><math>\rightarrow H \Rightarrow H - 2200 = 0</math>  <math>\Rightarrow H = 2200N</math> →</p> <p><math>\therefore</math> Design Hinge and all welds to sustain <math>H = 2200N</math>  <math>R = 200N</math> →</p> <p>Continued on page 11 →</p>	Chk
------	---	-----

Designed By: T J Mutenje	Date: 18/09/2010	Checked By:	Date:
-----------------------------	---------------------	-------------	-------

File: AI04- CATTLE FLOW CONTROL SYSTEM  
 Project Title: Research and Development of an RFID controlled cattle handling technology system prototype  
 Date: 18/09/2010

By: T J MUTENJE  
 Reviewed: Subject: CATTLE FLOW CONTROL SYSTEM  
 Page: 11

Units Listed     Numbers Checked     Sources Referenced     Inputs Listed

Item Design Title: continued from page 10

PNEUMATIC SYSTEM (ISO 6431 Type DNC/DKE

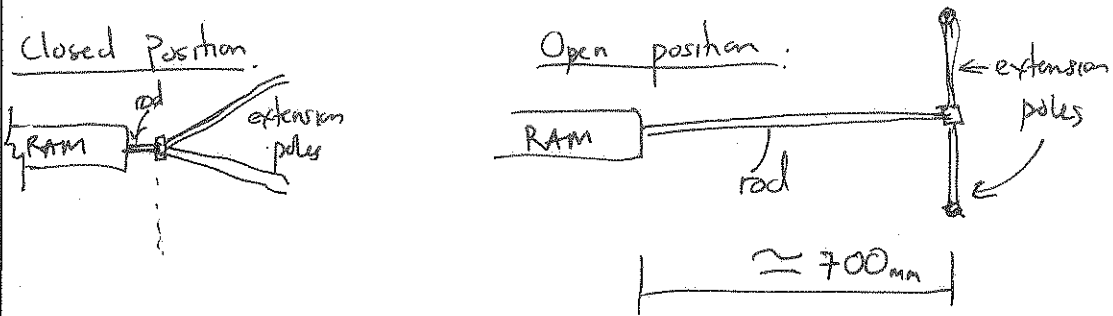

- (\*) Requirement 1 - Rod to extend  $\approx 700-750$ mm.
- (\*) Requirement 2 - Supply a retractive force of  $\approx 3$  kN
- (\*) Requirement 3 - Supply a push force of  $\approx 200$  N
- (\*) Requirement 4 - Thrust @ 600 kPa.
- (\*) Requirement 5 - Piston  $\phi \approx 100$ mm
- (\*) Requirement 6 - Foot mountings type HNC 100 Galvanised steel.
- (\*) Requirement 7 - Rod Eye type S9S - M20\*1,5
- (\*) Requirement 8 - Proximity sensor type SME-8-K-LED-330 <sup>socket</sup>
- (\*) Requirement 9 - Flow control valve.

CHOICE

To page: 12.

Designed By: \_\_\_\_\_ Date: \_\_\_\_\_ Checked By: \_\_\_\_\_ Date: \_\_\_\_\_



File <b>AI04- CATTLE FLOW CONTROL SYSTEM</b>	Project Title: Research and Development of an RFID controlled cattle handling technology system prototype	Date 18/09/2010
---	---	--------------------

By: <b>TJ MUTENJE</b>	Reviewed:	Subject: <b>CATTLE FLOW CONTROL SYSTEM</b>	Page: 12
---------------------------	-----------	---	-------------

Units Listed     
 Numbers Checked     
 Sources Referenced     
 Inputs Listed

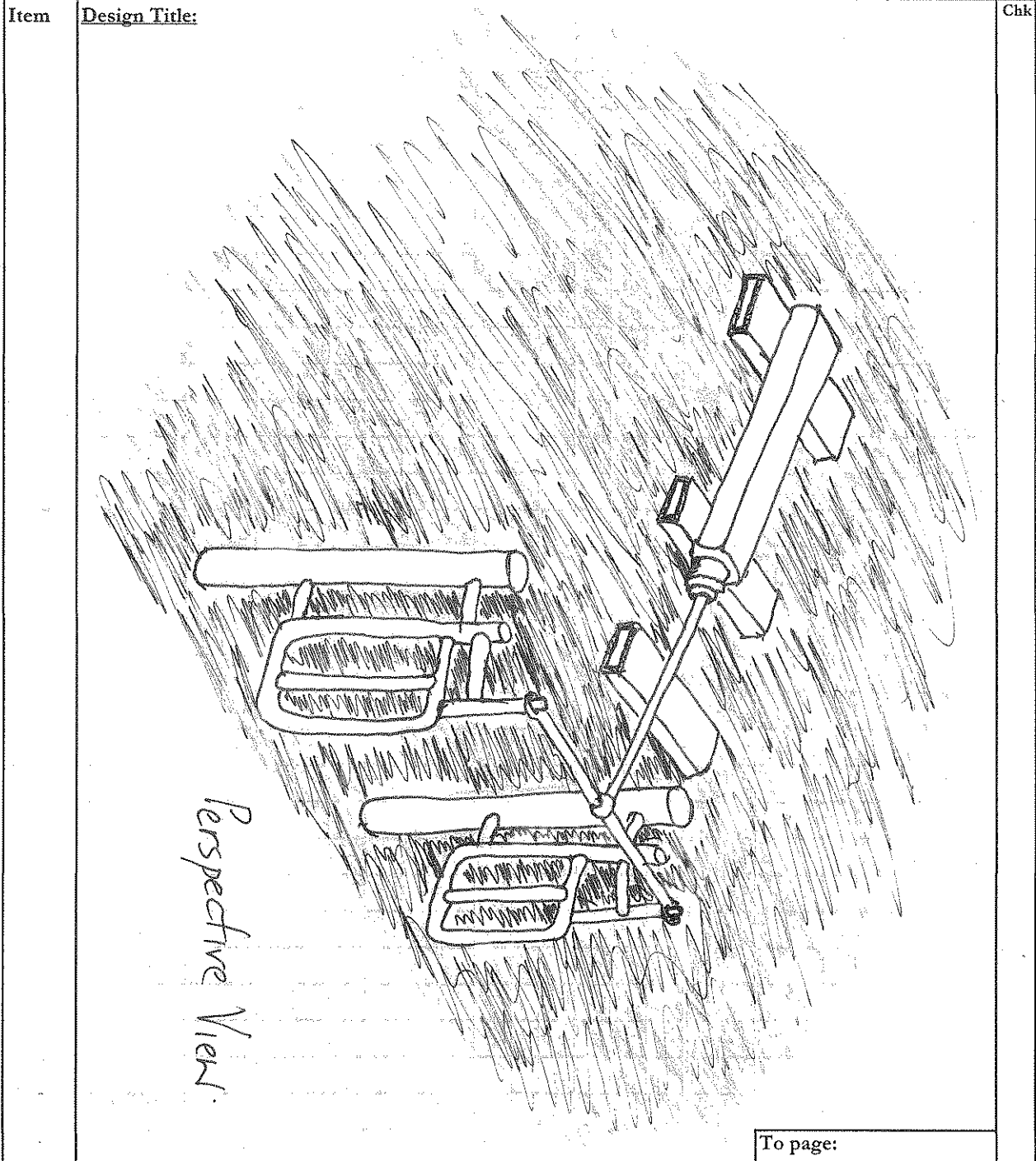

Designed By: <b>T J Mutenje</b>	Date: 19/09/2010	Checked By:	Date:
------------------------------------	---------------------	-------------	-------



File AI04-Cattle Sliding Gates	Project Title: Research and Development of an RFID controlled cattle handling technology system prototype	Date 20 September 2010
-----------------------------------	--	---------------------------

By: Tendai Justin Mutenje	Reviewed:	Subject: CATTLE SLIDING GATES SYSTEM	Page: COVER PAGE
---------------------------	-----------	---	---------------------

Units Listed     
 Numbers Checked     
 Sources Referenced     
 Inputs Listed

Item	Design Title:	Chk
	<p><b>DESIGN NOTES</b></p> <p><b>FOR THE</b></p> <p><b>CATTLE SLIDING GATES SYSTEM</b></p> <p><b>2 SINGLE SLIDING GATES</b></p> <p><b>7 PAGES</b></p>	
	To page: 1	

Designed By: Tendai Justin MUTENJE	Date: 20 Sept 2010	Checked By:	Date:
---------------------------------------	-----------------------	-------------	-------



Agricultural Research Council - Institute for Agricultural Engineering.  
Agricultural Infrastructure and Engineering Structures Division, Design & Calc, Modeling, Design & Drafting  
P Bag X519, Silverton, Pretoria, 0127 +27(0) 12 842 4000 www.arc.agric.za

File AI04-CATTLE SLIDING GATES	Project Title: Research and Development of an RFID controlled cattle handling technology system prototype	Date 19 SEPT 2010
--------------------------------------	--	----------------------

By: T J MUTENJE	Reviewed:	Subject: CATTLE SLIDING GATES	Page: 1
--------------------	-----------	----------------------------------	------------

Units Listed     
 Numbers Checked     
 Sources Referenced     
 Inputs Listed

Item	Design Title:	Chk
	<p align="center"><u>CATTLE SLIDING GATES (Notes 3)</u></p> <p><u>Design Considerations &amp; Problems</u></p> <ol style="list-style-type: none"> <li>① Alley flow control system</li> <li>② Anti <del>blo</del> backing, blocking, baulking and indexing</li> <li>③ Limited alley space for swing gate in system</li> <li>④ Remote control of slide gates</li> <li>⑤ Minimal walking distance of handler to open and close</li> <li>⑥ Cost effective system</li> <li>⑦ Better labour utilisation</li> </ol>	
	Continued to System design on page 2 →	To page: 2

Designed By: T J Mutenje	Date: 19/09/2010	Checked By:	Date:
-----------------------------	---------------------	-------------	-------

File <b>AI04-CATTLE SLIDING GATES</b>	Project Title: Research and Development of an RFID controlled cattle handling technology system prototype.	Date 19 SEPT 2010
--	---	----------------------

By: T J MUTENJE	Reviewed:	Subject: CATTLE SLIDING GATES	Page: 2
--------------------	-----------	----------------------------------	------------

<input type="checkbox"/> Units Listed	<input type="checkbox"/> Numbers Checked	<input type="checkbox"/> Sources Referenced	<input type="checkbox"/> Inputs Listed
---------------------------------------	--	---	--

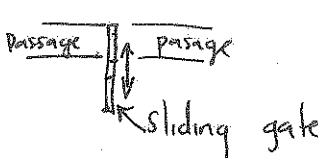
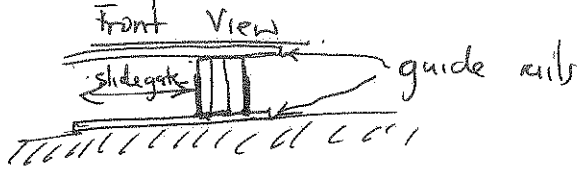
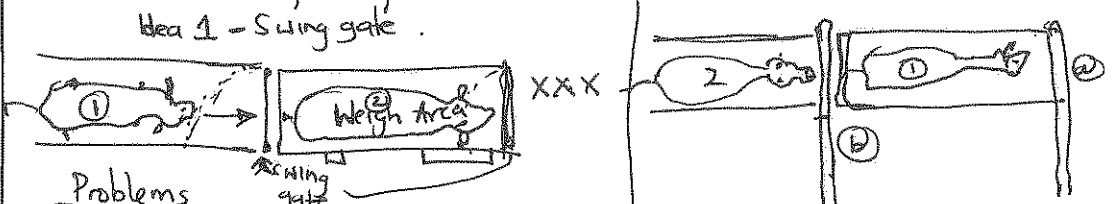
Item	Design Title:	Chk
	<p><u>DESIGN NOTES</u></p> <p><u>Purpose</u> - Slide sideways to block &amp; open narrow cattle lane as below</p> <p><u>Plan</u></p>  <p><u>Front View</u></p>  <p><u>Mainly Used in</u> - Narrow lanes and races</p> <p><u>Achievement Objective</u> - blocking, banking, indexing and anti-backing.</p> <p><u>Typical Use</u> - Used in places where there is limited room and a traditional swing gate would pose an obstruction in its open position as below</p> <p><u>Area 1 - Swing gate</u></p>  <p><u>Problems</u> As cattle 2 is still in the weigh ID area swing gate cant open forward so has to open backwards but cattle 1 is exactly in a blocking position thus gate fails to open. X X Chose sliding gate</p> <p>After cattle 1 is handled it move moves on as @ slides away and @ slides away also to allow cattle 2 to move into ID system.</p> <p>To page: 3.</p>	

Designed By: T J MUTENJE	Date: 19/09/2010	Checked By:	Date:
-----------------------------	---------------------	-------------	-------

File <b>AI04-CATTLE SLIDING GATES</b>		Project Title: Research and Development of an RFID controlled cattle handling technology system prototype	Date 19 SEPT 2010
By: <b>TJ MUTENJE</b>	Reviewed:	Subject: <b>CATTLE SLIDING GATES</b>	Page: <b>3</b>

Units Listed     
 Numbers Checked     
 Sources Referenced     
 Inputs Listed

Item	<p><u>Design Title:</u> continued from page 2 <u>Types of Sliding gates</u></p> <table border="0" style="width: 100%;"> <tr> <td style="width: 33%; vertical-align: top;"> <p>① <u>Manual operated gate</u></p> <ul style="list-style-type: none"> <li>- No electric &amp; pneumatic</li> <li>- Use gate latches to keep closed</li> <li>- Moved by human power</li> <li>XX - high manual labour requirement stressful</li> </ul> </td> <td style="width: 33%; vertical-align: top;"> <p>② <u>Pneumatic Gate</u></p> <ul style="list-style-type: none"> <li>- Pneumatic controlled</li> <li>- Remote controlled</li> <li>- less effort on handler</li> <li>- less human power</li> <li>✓✓ Chosen solution</li> </ul> </td> <td style="width: 33%; vertical-align: top;"> <p>③ <u>Pneumatic Split gate.</u></p> <ul style="list-style-type: none"> <li>- Split gates pneu. controlled</li> <li>- More expensive than single</li> <li>XX - to expensive</li> </ul> </td> </tr> </table> <p><u>Proposed Sketch:</u></p> <div style="display: flex; justify-content: space-around;"> <div style="text-align: center;"> <p>Gate in closed position</p> </div> <div style="text-align: center;"> <p>Gate in Open position</p> </div> </div> <p><u>Plan View with hidden details</u></p>	<p>① <u>Manual operated gate</u></p> <ul style="list-style-type: none"> <li>- No electric &amp; pneumatic</li> <li>- Use gate latches to keep closed</li> <li>- Moved by human power</li> <li>XX - high manual labour requirement stressful</li> </ul>	<p>② <u>Pneumatic Gate</u></p> <ul style="list-style-type: none"> <li>- Pneumatic controlled</li> <li>- Remote controlled</li> <li>- less effort on handler</li> <li>- less human power</li> <li>✓✓ Chosen solution</li> </ul>	<p>③ <u>Pneumatic Split gate.</u></p> <ul style="list-style-type: none"> <li>- Split gates pneu. controlled</li> <li>- More expensive than single</li> <li>XX - to expensive</li> </ul>	Chk
<p>① <u>Manual operated gate</u></p> <ul style="list-style-type: none"> <li>- No electric &amp; pneumatic</li> <li>- Use gate latches to keep closed</li> <li>- Moved by human power</li> <li>XX - high manual labour requirement stressful</li> </ul>	<p>② <u>Pneumatic Gate</u></p> <ul style="list-style-type: none"> <li>- Pneumatic controlled</li> <li>- Remote controlled</li> <li>- less effort on handler</li> <li>- less human power</li> <li>✓✓ Chosen solution</li> </ul>	<p>③ <u>Pneumatic Split gate.</u></p> <ul style="list-style-type: none"> <li>- Split gates pneu. controlled</li> <li>- More expensive than single</li> <li>XX - to expensive</li> </ul>			

continued to page 4

To page: 4

Designed By: <b>TJ Mutenje</b>	Date: 19 Sept 2010	Checked By:	Date:
-----------------------------------	-----------------------	-------------	-------

File AI04-CATTLE SLIDING GATES	Project Title: Research and Development of an RFID controlled cattle handling technology system prototype	Date 19 SEPT 2010
--------------------------------------	---	----------------------

By: T J MUTENJE	Reviewed:	Subject: CATTLE SLIDING GATES	Page: 4
--------------------	-----------	----------------------------------	------------

Units Listed     
 Numbers Checked     
 Sources Referenced     
 Inputs Listed

Item	Design Title: Continued from page 3	Chk
------	-------------------------------------	-----

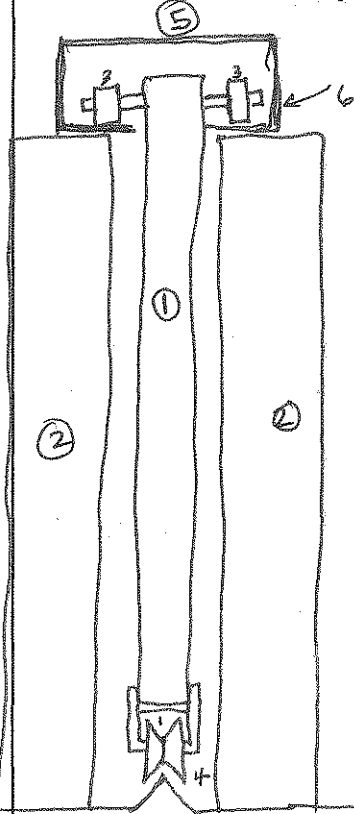

- ① Sliding gate
- ② Supporting poles (100 $\phi$ )
- ③ Rollers
- ④ V-shaped rollers
- ⑤ 120mm Lipped channel
- ⑥ 30\*50 mm angle iron
- ⑦ Rail support.

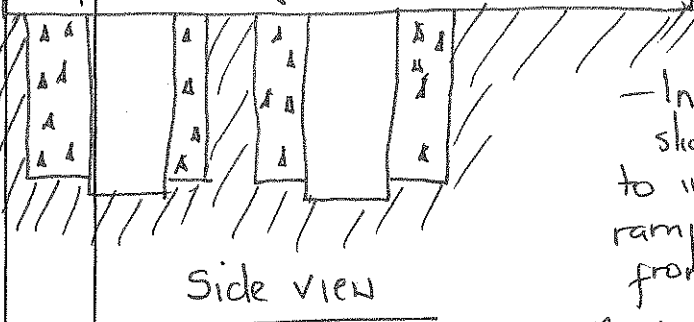

Suggestion:

- In order to automate the sliding gates there is need to introduce a compressed air ramp to open and shut gate from the top as below

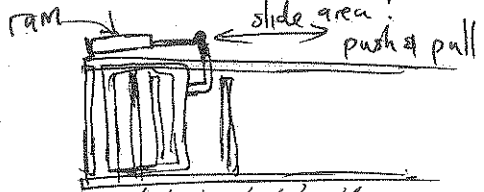

Continued to page 5 → To page: 5

Designed By: T J MUTENJE	Date: 19/09/2010	Checked By:	Date:
-----------------------------	---------------------	-------------	-------

File <b>AI04- CATTLE SLIDING GATES</b>	Project Title: Research and Development of an RFID controlled cattle handling technology system prototype	Date 19 SEPT 2010
---	---	----------------------

By: <b>T J MUTENJE</b>	Reviewed:	Subject: <b>CATTLE SLIDING GATES</b>	Page: <b>5</b>
----------------------------	-----------	---	-------------------

<input type="checkbox"/> Units Listed	<input type="checkbox"/> Numbers Checked	<input type="checkbox"/> Sources Referenced	<input type="checkbox"/> Inputs Listed
---------------------------------------	--	---	--

Item	Design Title: Continued from page 4	Chk
	<p>Free body diagram of sliding gate showing frictional forces on top rail and bottom rail.</p> <p>From <math>F_r = \mu N</math> where <math>F_r</math> = frictional force resisting motion  <math>\mu</math> = coefficient of friction  <math>N</math> = Reaction to gate weight</p> <p>Total gate weight = Mass/unit of structure * total length * g  <math>= 3,5 \text{ kg/m} * 10 \text{ m} * 10</math>  <math>= \underline{350 \text{ N}}</math></p> <p>Coefficient of top rail from tables <math>\mu_t = 2,8</math> (Materials tables)          Coefficient of bottom rail from tables <math>\mu_b = 3,2</math></p> <p><math>\therefore F_{r_{\text{top rail}}} = \mu_t * N = 2,8 * 350 = \underline{980 \text{ N}}</math>  <math>F_{r_{\text{bottom}}} = \mu_b * N = 3,2 * 350 = \underline{1120 \text{ N}}</math></p> <p><math>\therefore</math> Total force required including a safety factor of 1,3  <math>F_{\text{required}} = 1,3 * 2100</math>  <math>= \underline{2730 \text{ N}}</math></p> <p>Taken to Compressed air RAM selection</p>	
	Continued to page 6	To page: 6

Designed By: <b>T J Mutenje</b>	Date:	Checked By:	Date:
------------------------------------	-------	-------------	-------

File AI04- CATTLE SLIDING GATE	Project Title: Research and Development of an RFID controlled cattle handling technology system prototype	Date 19 Sept 2010
--------------------------------------	---	----------------------

By: TJ MUTENJE	Reviewed:	Subject: CATTLE SLIDING GATES	Page: 6
-------------------	-----------	----------------------------------	------------

<input type="checkbox"/> Units Listed	<input type="checkbox"/> Numbers Checked	<input type="checkbox"/> Sources Referenced	<input type="checkbox"/> Inputs Listed
---------------------------------------	--	---	--

Item	Design Title: continued from page 5.	Chk
------	---	-----

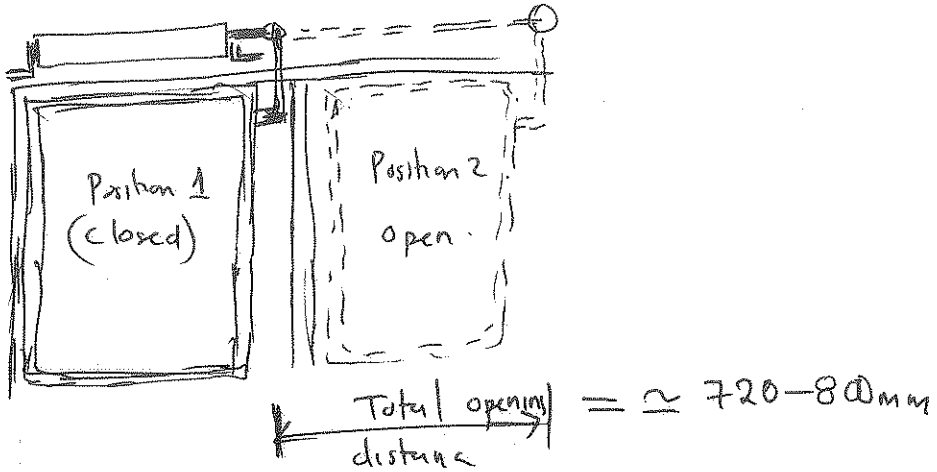

- (\*) Requirement 1 - Compressed air ram of a output both thrust and Return of 2,8 kN (506431)
- (\*) Requirement 2 - Stroke length of 700-750mm
- (\*) Requirement 3 - Operating pressure 600 kPa.
- (\*) Requirement 4 - Piston diameter  $\phi 100 - \phi 80$
- (\*) Requirement 5 - Foot mounting types HNC-100
- (\*) Requirement 6 - Rod eye type SSS - M20x1,5

CHOICE

Continued to Page 7

To page: 7

Designed By: T J MUTENJE	Date:	Checked By:	Date:
-----------------------------	-------	-------------	-------

File AI04- CATTLE SLIDING SATE	Project Title: Research and Development of an RFID controlled cattle handling technology system prototype	Date 19 SEPT 2010
--------------------------------------	---	----------------------

By: TJ MUTENJE	Reviewed:	Subject: CATTLE SLIDING SATE	Page: 7
-------------------	-----------	---------------------------------	------------

Units Listed     
 Numbers Checked     
 Sources Referenced     
 Inputs Listed

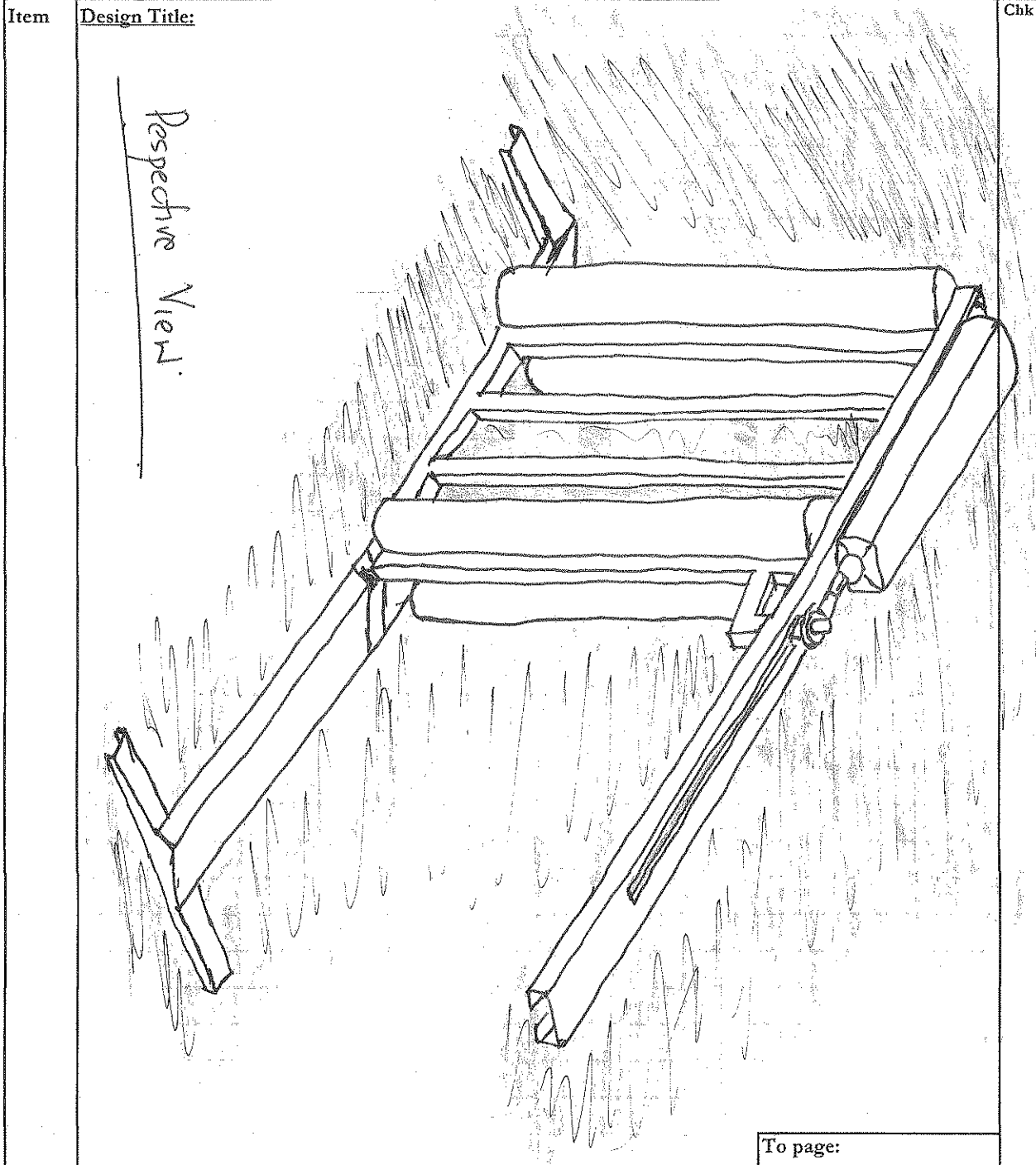

Designed By:	Date:	Checked By:	Date:
--------------	-------	-------------	-------



File <b>AI04-CATTLE ID/ WEIGH BOX</b>	Project Title: Research and Development of an RFID controlled cattle handling technology system prototype	Date <b>20 September 2010</b>
--	---	--------------------------------------

By: Tendai Justin Mutenje	Reviewed:	Subject: CATTLE IDENTIFICATION AND WEIGH BOX SYSTEM	Page: COVER PAGE
------------------------------	-----------	--	---------------------

Units Listed     
 Numbers Checked     
 Sources Referenced     
 Inputs Listed

Item	<u>Design Title:</u>	<p><b>DESIGN NOTES</b></p> <p><b>FOR THE</b></p> <p><b>CATTLE IDENTIFICATION AND</b></p> <p><b>WEIGH BOX SYSTEM</b></p> <p><b>12 PAGES</b></p>	Chk
		To page: 1	

Designed By: Tendai Justin MUTENJE	Date: 30 Aug 2010	Checked By:	Date:
---------------------------------------	----------------------	-------------	-------



Agricultural Research Council - Institute for Agricultural Engineering.  
Agricultural Infrastructure and Engineering Structures Division, Design & Calcs, Modeling, Design & Drafting  
P Bag X519, Silverton, Pretoria, 0127 +27(0) 12 842 4000 www.arc.agric.za

File <b>AI04- CATTLE ID/WEIGH BOX</b>	Project Title: Research and Development of an RFID controlled cattle handling technology system prototype	Date 19 SEPT 2010
--	---	----------------------

By: <b>TJ MUTENJE</b>	Reviewed:	Subject: <b>CATTLE IDENTIFICATION AND WEIGH BOX</b>	Page: <b>1</b>
---------------------------	-----------	--	-------------------

Units Listed    
 Numbers Checked    
 Sources Referenced    
 Inputs Listed

Item	Design Title: <b>CATTLE IDENTIFICATION AND WEIGH BOX DESIGN</b>	Chk
------	---	-----

DESIGN Considerations & Problems Associated (Notes 4)

- ① Accurate cattle identification
- ② Quick identification (short identification time)
- ③ Accurate cattle weighing system
- ④ Short weighing duration.
- ⑤ Safe cattle platforms
- ⑥ Humane cattle system.
- ⑦ Efficient cattle identification and weighing system.

Continued to page 2 for system design → To page: **2**

Designed By: <b>TJ MUTENJE</b>	Date: <b>19/09/2010</b>	Checked By:	Date:
-----------------------------------	----------------------------	-------------	-------



File AI04- CATTLE ID/WEIGH BOX		Project Title: Research and Development of an RFID controlled cattle handling technology system prototype		Date 19 Sept 2010
By: TJ MUTENJE	Reviewed:	Subject: CATTLE IDENTIFICATION AND WEIGH BOX		Page: 2

Units Listed     
 Numbers Checked     
 Sources Referenced     
 Inputs Listed

Item	Design Title:	Chk
	Continued from page 1	
①	<u>IDENTIFICATION SYSTEM</u> - Cattle RFID Tags as concluded in Proposal - Panel Readers as concluded in Proposal	
②	<u>Weighing System</u> - Electronic scale as concluded in proposal - Electronic reading unit - RFID Compatible scale which auto capture data to external device.	
③	<u>Data Capture and Softwares</u> - RFID Compatible data system - Management Software (for decision making) * - Weight based sorting programming.	
	<u>Importance of ID/Weigh box</u> - When dealing with large numbers of cattle to save a lot of time and money - Data obtained is important, whether one want to know progress on weight gains for rations decisions - By isolating each animal you will know exactly which animals have missing or non-reading tags.  * As earlier concluded in design of control gates. - Sliding gates will be used before and after the weigh/identification box	
	continued to page 3	
		To page: 3

Designed By: TJ MUTENJE	Date: 19/09/2010	Checked By:	Date:
----------------------------	---------------------	-------------	-------

File <b>AI04- ID &amp; WEIGH BOX SYSTEM</b>	Project Title: Research and Development of an RFID controlled cattle handling technology system prototype	Date 20 SEPT 2010
--	---	----------------------

By: TJ MUTENJE	Reviewed:	Subject: CATTLE WEIGH BOX AND ID SYSTEM	Page: 3
-------------------	-----------	--	------------

Units Listed    
 Numbers Checked    
 Sources Referenced    
 Inputs Listed

Item	<p><b>Design Title:</b> Continued from page - 2.</p> <p><u>ID and Weighbox features and Considerations. (ISO 11784 &amp; 11785)</u></p> <ul style="list-style-type: none"> <li>- Rear sliding gate air operated</li> <li>- Front sliding gate air operated</li> <li>- Hardwood timber rails and form ply sheeting for RFID scanning</li> <li>- Platform <ul style="list-style-type: none"> <li>• Load bars</li> <li>• Load bar cables</li> <li>• Weigh indicator</li> <li>• Scale software.</li> </ul> </li> </ul> <p style="margin-left: 40px;">} Scale/Weigh system and software.</p> <ul style="list-style-type: none"> <li>* - Suspended weigh box to keep loadbars out of muck &amp; moisture</li> <li>- UV Stable nylon wheels on gates.</li> <li>- Panel reader (RFID) and software. (Antenna &amp; reader control)</li> <li>- RFID Tags</li> <li>- Visual tags.</li> <li>- Automation &amp; Compressed air Control box</li> <li>- Cattle management software</li> <li>-</li> </ul> <p><u>Purpose and functions of reader</u></p> <ul style="list-style-type: none"> <li>- Generates the signal used to excite the RFID device (Tag RFID)</li> <li>- Decodes the signal returned from tags</li> <li>- Cables to computer, scale etc.</li> </ul> <p><u>Considerations for panel reader installations</u></p> <ul style="list-style-type: none"> <li>* - Avoid metals that are magnetic as they degrade read range through absorption and deflection of the panel reader magnetic fields</li> <li>* - Ply wood intalation between reader to avoid direct exposure of reader to horns</li> </ul>	Chk
	4	To page: 4

Designed By: T J MUTENJE	Date: 20 SEPT 2010	Checked By:	Date:
-----------------------------	-----------------------	-------------	-------

File <b>AI04- ID &amp; WEIGH Box SYSTEM</b>	Project Title: Research and Development of an RFID controlled cattle handling technology system prototype	Date 20 SEPT 2010
--	---	----------------------

By: TJ MUTENJE	Reviewed:	Subject: CATTLE WEIGH BOX AND ID SYSTEM	Page: 4
-------------------	-----------	--	------------

<input type="checkbox"/> Units Listed	<input type="checkbox"/> Numbers Checked	<input type="checkbox"/> Sources Referenced	<input type="checkbox"/> Inputs Listed
---------------------------------------	--	---	--

Item	Design Title: Continued from page 3	Chk
------	-------------------------------------	-----

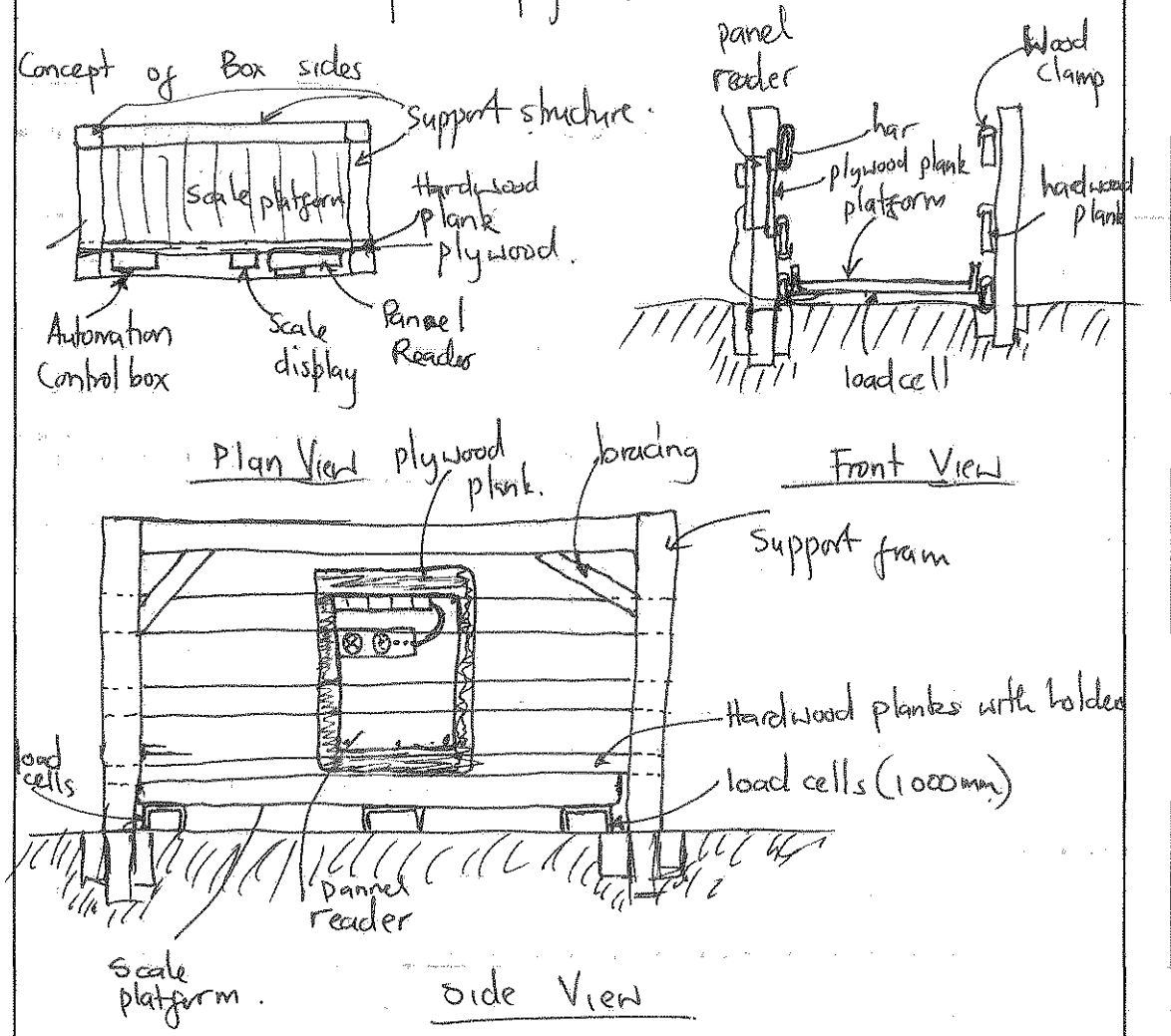

- Specifications
- Total Material weight  $\approx 150$  kg (dead load)
  - load cells to support platform, dead load and live weight  $\approx 2000$  kg  $\approx 20$  kN
  - Loadbars length 1000mm with 20kN capacity
  - Non-slip checker plate floor grid.
  - 3mm steel sides - 6mm poly urethane cables

Designed By:	Date:	Checked By:	Date:
--------------	-------	-------------	-------

File AI04- 10 * WEISH Box SYSTEM	Project Title: Research and Development of an RFID controlled cattle handling technology system prototype	Date 20 SEPT 2010
By: T J MUTENJE	Reviewed:	Subject: CATTLE WEISH BOX AND IO SYSTEM
		Page: 5

Units Listed     Numbers Checked     Sources Referenced     Inputs Listed

Item	Design Title: continued from page 4	Chk
------	-------------------------------------	-----

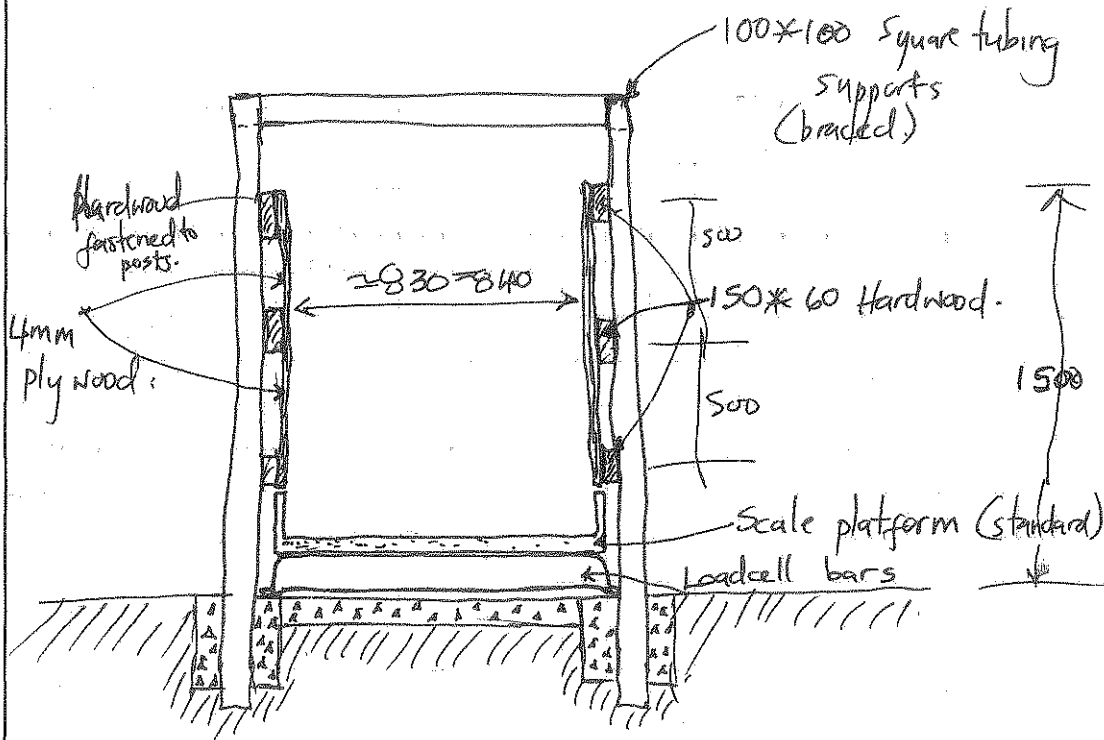

Notes

- Hardwood timber rails and form ply sheeting for accurate RFID Scanning.

Continued to page 6 →

To page: 6

Designed By: T J MUTENJE	Date: 20/09/2010	Checked By:	Date:
-----------------------------	---------------------	-------------	-------



File <b>AI04-ID &amp; WEIGH BOX SYSTEM</b>	Project Title: Research and Development of an RFID controlled cattle handling technology system prototype	Date <b>20 SEPT 2010</b>
---	---	-----------------------------

By: <b>TJ MUTENJE</b>	Reviewed:	Subject: <b>CATTLE WEIGH BOX AND ID SYSTEM</b>	Page: <b>6</b>
---------------------------	-----------	---	-------------------

Units Listed    
 Numbers Checked    
 Sources Referenced    
 Inputs Listed

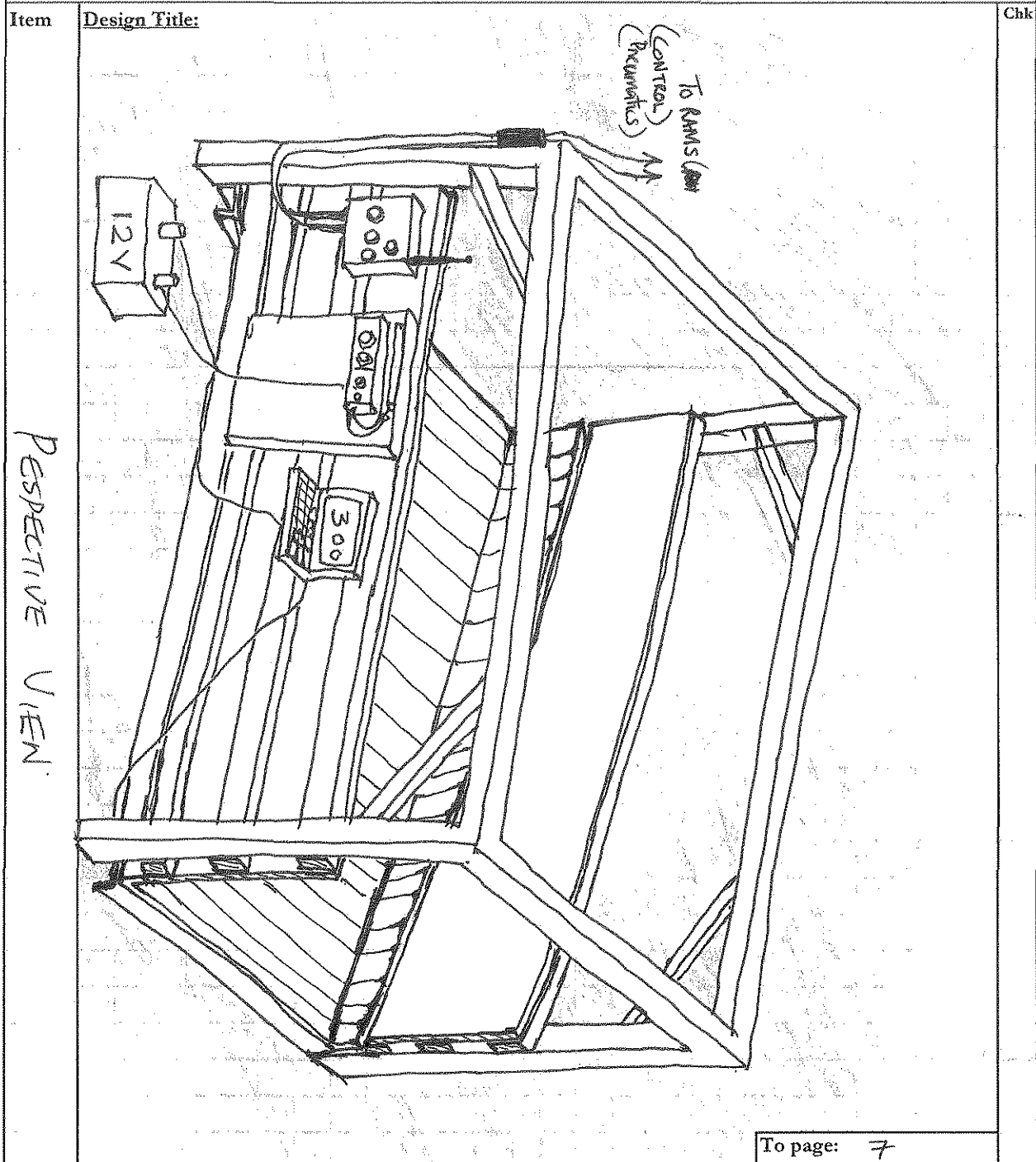

Designed By: <b>TJ MUTENJE</b>	Date: <b>20/09/2010</b>	Checked By:	Date:
-----------------------------------	----------------------------	-------------	-------



File <b>AI04-Cattle Neck &amp; Body Clamp</b>	Project Title: Research and Development of an RFID controlled cattle handling technology system prototype	Date <b>21 September 2010</b>
--	--	----------------------------------

By: Tendai Justin Mutenje	Reviewed:	Subject: CATTLE RESTRAINING SYSTEM	Page: COVER PAGE
------------------------------	-----------	---------------------------------------	---------------------

Units Listed     
 Numbers Checked     
 Sources Referenced     
 Inputs Listed

Item	<u>Design Title:</u>	<p><b>DESIGN NOTES</b></p> <p><b>FOR THE</b></p> <p><b>CATTLE RESTRAINING SYSTEM</b></p> <p><b>NECK AND BODY CLAMP</b></p> <p><b>3 PAGES</b></p>	Chk
		To page: 1	

Designed By: Tendai Justin MUTENJE	Date: 21 Sept 2010	Checked By:	Date:
---------------------------------------	-----------------------	-------------	-------





File AI04-NECK AND BODY CLAMP	Project Title: Research and Development of an RFID controlled cattle handling technology system prototype	Date 20 SEPT 2010
By: T J MUTENJE	Reviewed:	Subject: NECK AND BODY CLAMP FOR CATTLE
		Page: 1

Units Listed     Numbers Checked     Sources Referenced     Inputs Listed

Item	Design Title:	Chk
	<p>SELECTION CHARACTERISTICS OF CATTLE NECK AND BODY CLAMP</p> <p><u>Required Characteristics and specifications.</u></p> <ul style="list-style-type: none"> <li>* Near side and offside operations</li> <li>* Walk through head bail (V-opening)</li> <li>* Mechanical headbail locking system - no ratched noise and infinite adjustment</li> <li>* Headbail operation from front and rear of crush</li> <li>* Full height gate on non-operating side</li> <li>* Split gates on operating side</li> <li>* Ratchet push up bars</li> <li>* Floor - 3mm checker plate, welded or bolted in</li> <li>* Hearvey duty slam latches</li> <li>* Grease nipples</li> <li>* Drop away handles for safety.</li> </ul> <p>an example concept isometric of the desired Neck &amp; body clamp will be shown</p> <p style="text-align: center;">continued to page</p>	
		To page: 2

Designed By: T J MUTENJE	Date: 20/09/2010	Checked By:	Date:
-----------------------------	---------------------	-------------	-------

File <b>AI04- NECK AND BODY CLAMP</b>	Project Title: Research and Development of an RFID controlled cattle handling technology system prototype	Date 20 SEPT 2010
--	--	----------------------

By: <b>T J MUTENJE</b>	Reviewed:	Subject: <b>NECK AND BODY CLAMP FOR CATTLE</b>	Page: <b>2</b>
------------------------	-----------	---	-------------------

Units Listed    
 Numbers Checked    
 Sources Referenced    
 Inputs Listed

Item	Design Title:	Chk
	<p>continued from page 1</p> <p><u>Purpose and importance of the crush Assembly.</u></p> <ul style="list-style-type: none"> <li>⊛ Side frames between which cattle is driven and caught both neck and body for working purposes when dealing with wild animals.</li> <li>⊛ Allows working on cattle in its same position</li> <li>⊛ Crush to be about 2m long, 2m high and 0,7m wide</li> </ul>	
<p>Continued to page. 3 →</p>		<p>To page: 3</p>

Designed By: <b>T J Mutenje</b>	Date: 20 Sept 2010	Checked By:	Date:
------------------------------------	-----------------------	-------------	-------



File <b>AI04-Handler Access Gates</b>		Project Title: <b>Research and Development of an RFID controlled cattle handling technology system prototype</b>		Date <b>21 September 2010</b>
By: Tendai Justin Mutenje	Reviewed:	Subject: <b>HANDLER ACCESS GATES</b>		Page: <b>COVER PAGE</b>
<input type="checkbox"/> Units Listed		<input type="checkbox"/> Numbers Checked		<input type="checkbox"/> Sources Referenced
				<input type="checkbox"/> Inputs Listed
Item	Design Title:			Chk
<p><b>DESIGN NOTES</b></p> <p><b>FOR THE</b></p> <p><b>HANDLER ACCESS GATES</b></p> <p><b>ACCESS SWING GATES</b></p> <p><b>4 PAGES</b></p>				
				To page: 1
Designed By: <b>Tendai Justin MUTENJE</b>		Date: <b>21 Sept 2010</b>	Checked By:	Date:
		<b>Agricultural Research Council - Institute for Agricultural Engineering.</b> Agricultural Infrastructure and Engineering Structures Division, Design & Cales, Modeling, Design & Drafting P Bag X519, Silverton, Pretoria, 0127 +27(0) 12 842 4000 www.arc.agric.za		

File AI04- HANDLER ACCESS GATES	Project Title: Research and Development of an RFID controlled cattle handling technology system prototype	Date 21 SEPT 2010
By: T J MUTENJE	Reviewed: Subject: HANDLER ACCESS GATES	Page: 1

Units Listed   
 Numbers Checked   
 Sources Referenced   
 Inputs Listed

Item	Design Title:	Chk
	<u>DESIGN NOTES FOR HANDLER ACCESS GATES</u>  <u>Purpose of Handler Access Gates</u>  <ul style="list-style-type: none"> <li>⊛ Allow passage of handler between near side and far side during handling of cattle</li> <li>⊛ Enables administering <sup>passage</sup> of cattle dosage</li> <li>⊛ Allows handler to safely maneuver in and out of the passage or cattle alleyway freely.</li> <li>⊛ Channels cattle to the sorting system.</li> </ul>	
Continued to page 2. →		To page: 2.

Designed By: T J Mutenje	Date: 21/09/2010	Checked By:	Date:
-----------------------------	---------------------	-------------	-------

File <b>AI04- HANDLER ACCESS GATES</b>	Project Title: Research and Development of an RFID controlled cattle handling technology system prototype	Date 21 SEPT 2010
---	---	----------------------

By: T J MUTENJE	Reviewed:	Subject: HANDLER ACCESS GATES.	Page: 2
--------------------	-----------	-----------------------------------	------------

Units Listed    
 Numbers Checked    
 Sources Referenced    
 Inputs Listed

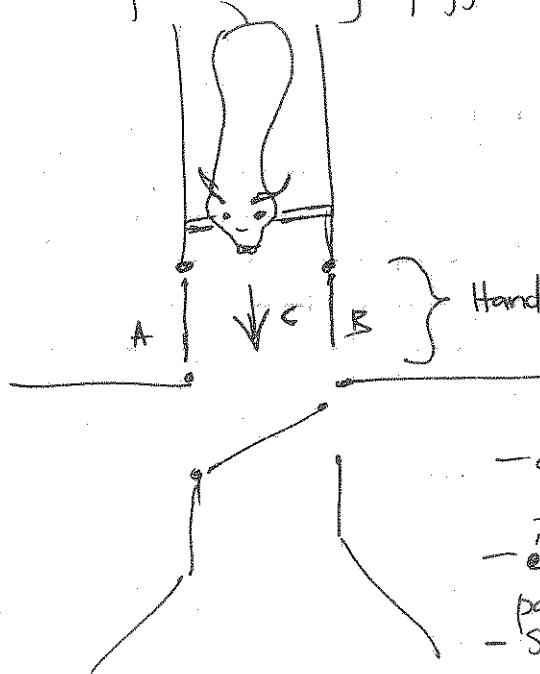
Item	Design Title: <u>Key features / Requirements / Specification</u>	Continued from page 1	Chk
	<p>- Inhibit cattle from exiting passage alley as below</p>  <ul style="list-style-type: none"> <li>- allow passage of handler from side A to B</li> <li>- enable handler to work in passage C in front of cow</li> <li>- Safety provision to handler after works finish and when cattle pass</li> </ul>		
	<p><u>Desired characteristics</u></p> <ul style="list-style-type: none"> <li>- at least 750 mm wide to allow items like computers and readers to be transferred from B to A</li> <li>- At least 250 mm from ground to avoid effects of sag</li> <li>- At least <sup>to is</sup> 1500 mm from the ground to be consistent with whole cattle fence</li> <li>- Solid sheeted to inhibit cattle from entering.</li> </ul>		
	continued to page 3. →		To page: 3

Designed By: T J MUTENJE	Date: 21/09/2010	Checked By:	Date:
-----------------------------	---------------------	-------------	-------

File <b>A104 HANDLER ACCESS GATE</b>	Project Title: Research and Development of an RFID controlled cattle handling technology system prototype	Date 21 SEPT 2010
---	---	----------------------

By: <b>T J MUTENJE</b>	Reviewed:	Subject: <b>HANDLER ACCESS GATES</b>	Page: <b>3</b>
----------------------------	-----------	---	-------------------

Units Listed   
 Numbers Checked   
 Sources Referenced   
 Inputs Listed

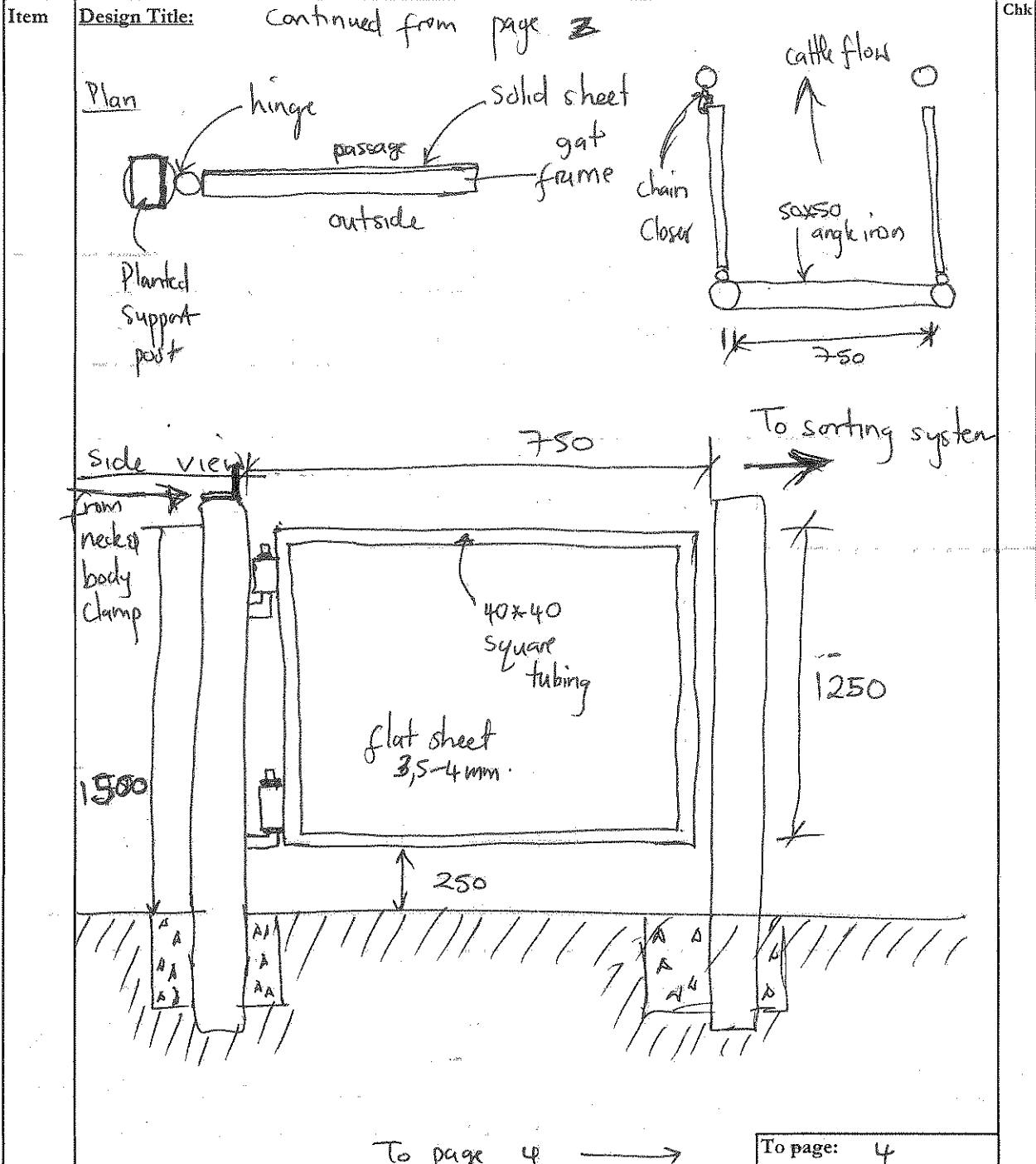

Designed By: <b>T J MUTENJE</b>	Date: 21/09/2010	Checked By:	Date:
------------------------------------	---------------------	-------------	-------

File <b>AI04 HANDLER ACCESS GATES</b>	Project Title: Research and Development of an RFID controlled cattle handling technology system prototype	Date 21 SEPT 2010
--	---	----------------------

By: <b>TJ MUTENJE</b>	Reviewed:	Subject: <b>HANDLER ACCESS GATES</b>	Page: 4
---------------------------	-----------	---	------------

Units Listed   
 Numbers Checked   
 Sources Referenced   
 Inputs Listed

Item	Design Title: <i>continued from page 3</i>		Chk
		To page:	

Designed By: <b>T J MUTENJE</b>	Date: 21/09/2010	Checked By:	Date:
------------------------------------	---------------------	-------------	-------

File <b>AI04-Cattle Sorting Gates</b>	Project Title: Research and Development of an RFID controlled cattle handling technology system prototype	Date <b>21 September 2010</b>
--	--	----------------------------------

By: Tendai Justin Mutenje	Reviewed:	Subject: CATTLE SORTING GATES	Page: COVER PAGE
------------------------------	-----------	----------------------------------	---------------------

<input type="checkbox"/> Units Listed	<input type="checkbox"/> Numbers Checked	<input type="checkbox"/> Sources Referenced	<input type="checkbox"/> Inputs Listed
---------------------------------------	--	---	--

Item	Design Title:	Chk
	<p><b>DESIGN NOTES</b></p> <p><b>FOR THE</b></p> <p><b>CATTLE SORTING GATES</b></p> <p><b>DRAFTING SWING GATES</b></p> <p><b>6 PAGES</b></p>	
	To page: 1	

Designed By: Tendai Justin MUTENJE	Date: 21 Sept 2010	Checked By:	Date:
---------------------------------------	-----------------------	-------------	-------



File <b>AI04-CATTLE SORTING GATES</b>		Project Title: Research and Development of an RFID controlled cattle handling technology system prototype	Date 21 SEPT 2010
By: T J MUTENJE	Reviewed:	Subject: CATTLE SORTING GATES	Page: 1

Units Listed    
 Numbers Checked    
 Sources Referenced    
 Inputs Listed

Item	Design Title:	Chk
	<u>DESIGN NOTES &amp; REQUIREMENTS CATTLE SORTING GATES</u>  <u>Design Requirements</u>  ① Lane drafting Unit ② Low stress handling system ③ Pneumatic Controlled System ④ Sorting on weight basis ⑤ 3 camp sorting system ⑥ Hand held remote controlled or computer based sorting ⑦ <u>Summary</u> - low stress - little or no trauma to livestock and safer to handler - located after crush leading to holding camps - Pneumatically controlled - Suit automation combined with weight or identification decisions - Hot dipped galvanised for anti corrosion - Rubber buffers to reduce noise - Remote / computer controlled operations	
continued to Page 2 →		To page: 2

Designed By: T J MUTENJE	Date: 21/09/2010	Checked By:	Date:
-----------------------------	---------------------	-------------	-------



File <b>AI04- CATTLE SORTING GATES</b>	Project Title: Research and Development of an RFID controlled cattle handling technology system prototype	Date 21 SEPT 2010
By: <b>TJ MUTENJE</b>	Reviewed:	Page: 2
Subject: <b>CATTLE SORTING GATES</b>		

Units Listed   
 Numbers Checked   
 Sources Referenced   
 Inputs Listed

Item	Design Title: continued from page 1	Chk
------	-------------------------------------	-----

Basic Concept

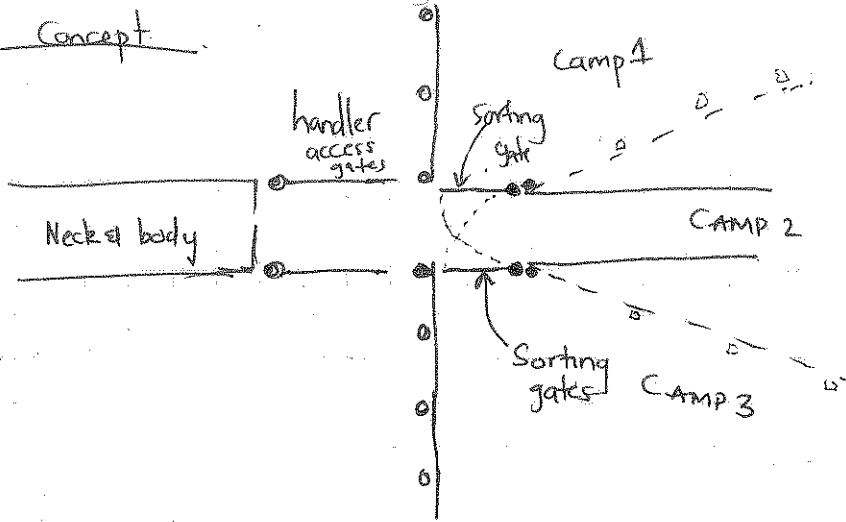

View into sorting gates

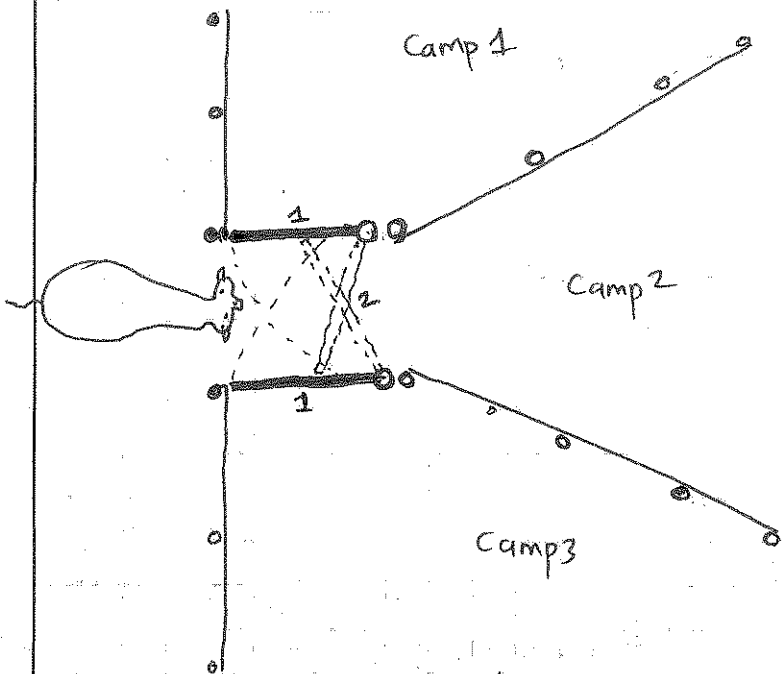

Procedure

- Cattle arrive at sorting system with gates in positions
- Closed gate is position 1
- Open ~~position~~ is position 2
- ~~then~~ Cattle enter sorted to camp ①, ② or 3 depending on decision (Weight basis)
- Gate return to default position 1 after sorting

continued to page 3 →

To page: **3**

Designed By: <b>TJ MUTENJE</b>	Date: 21/09/2010	Checked By:	Date:
-----------------------------------	---------------------	-------------	-------



File <b>AI04- CATTLE SORTINS GATES</b>	Project Title: <b>Research and Development of an RFID controlled cattle handling technology system prototype</b>	Date <b>21 Sept 2010</b>
---	---	-----------------------------

By: <b>TJ MUTENJE</b>	Reviewed:	Subject: <b>CATTLE SORTINS GATES</b>	Page: <b>3</b>
-----------------------	-----------	---	-------------------

Units Listed    
 Numbers Checked    
 Sources Referenced    
 Inputs Listed

Item	Design Title:	Chk
	<p>Adopting other sorting gate system</p> <p>Introducing automation.</p> <p>Concept sketch</p> <p>① Gate direction position ② Gate default position</p> <p>support Ram Post support (100*100 Square tubing) (5mm) rubber stopper</p>	
	To page: <b>4</b>	

Designed By: <b>TJ MUTENJE</b>	Date: <b>21/09/2010</b>	Checked By:	Date:
-----------------------------------	----------------------------	-------------	-------



File <b>AI04- CATTLE SORTING SATES</b>	Project Title: Research and Development of an RFID controlled cattle handling technology system prototype	Date 21 SEPT 2010
---	--	----------------------

By: <b>TJ MUTENJE</b>	Reviewed:	Subject: <b>CATTLE SORTING SATES</b>	Page: 4
-----------------------	-----------	---	------------

Units Listed    
 Numbers Checked    
 Sources Referenced    
 Inputs Listed

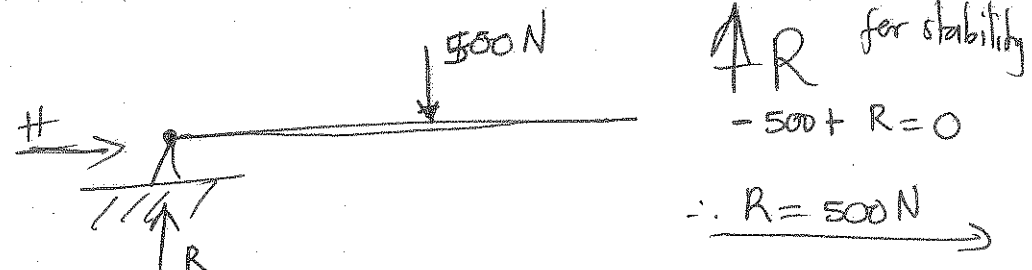
Item	Design Title: <u>continued from page 3</u>  <u>Stability check.</u>  Total weight supported = Gate Weight = Mass/m * total Material $= 3,5 \text{ kg/m} * 12,8 \text{ m} * g$ $= 44,8 \text{ kg} * 10$ $= 448 \text{ N} \rightarrow \approx 500 \text{ N} \text{ (1,3 safety factor)}$  Assuming below    $\therefore$ the hinges must support $\approx 500 \text{ N}$ minimum  Taking the whole load supported by the support structure $\approx 500$ from tables $100 * 100 \text{ mm} * 5 \text{ mm}$ square tubing supports load  From literature Force from cow < allowable max load.  From tables Max allowable load = $6,5 \text{ kN} >$ Cattle force $\approx 3,5 \text{ kN}$ $\therefore$ the $100 * 100 * 5 \text{ mm}$ square tubing is <sup>sustainable</sup>	Chk
------	---	-----

Designed By:	Date:	Checked By:	Date:
--------------	-------	-------------	-------

File AI04- CATTLE SORTINS SATES	Project Title: Research and Development of an RFID controlled cattle handling technology system prototype	Date 21 Sept 2010
---------------------------------------	---	----------------------

By: T J MUTENJE	Reviewed:	Subject: CATTLE SORTINS SATES	Page: 5.
--------------------	-----------	----------------------------------	-------------

Units Listed     Numbers Checked     Sources Referenced     Inputs Listed

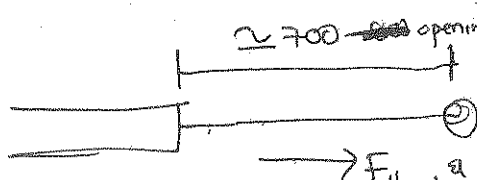
Item	<p><u>Design Title:</u> continued from page 4</p> <p><u>RAM &amp; Pneumatic selection.</u></p> <p>For functionality (Weight of gate + Cattle force) must be sustained by RAM for <u>limit state</u> to be achieved</p> <p>(*) Total limit state = ((Cattle + load) force) * Safety  <math>= (2,5 \text{ kN} + 0,5 \text{ kN}) * 1,3</math>  <math>= 3,9 \text{ kN} \rightarrow \approx 4 \text{ kN}</math></p> <p>(*) From ISO 6431  Select </p> <p>(*) Operating at 600 kPa.</p> <p>(*) Piston <math>\phi = 100 \text{ mm}</math></p> <p>(*) Foot mounting type HNC 100 Galvanised steel with swivel or spindle as the system takes a rotation.</p> <p>(*) Rod Eye type SSS-M20 * 1,5</p> <p>(*) Proximity Sensor types SME-8-K-LED-230 and socket.</p> <p>(*) Flow control valve and remote system</p>	Chk
------	--	-----

continued to page 6      To page: 6

Designed By: T J Mutenje	Date: 21/09/2010	Checked By:	Date:
-----------------------------	---------------------	-------------	-------



File <b>AI04-CATTLE SORTING SATES</b>	Project Title: Research and Development of an RFID controlled cattle handling technology system prototype	Date 21 SEPT 2010
--	---	----------------------

By: <b>TJ MUTENJE</b>	Reviewed:	Subject: <b>CATTLE SORTING SATES</b>	Page: 6
---------------------------	-----------	---	------------

Units Listed    
 Numbers Checked    
 Sources Referenced    
 Inputs Listed

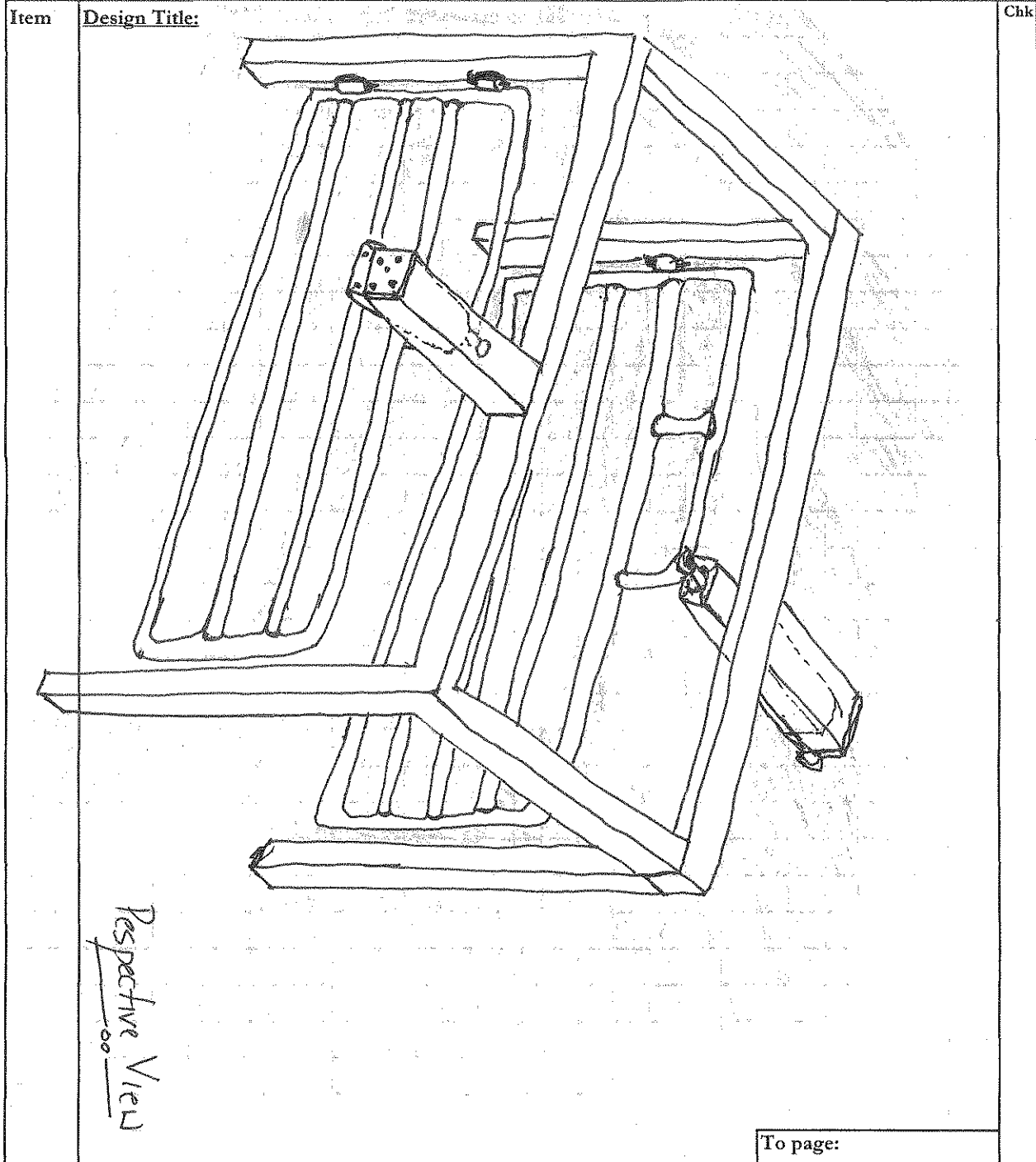

Designed By: <b>TJ MUTENJE</b>	Date: 21/09/2010	Checked By:	Date:
-----------------------------------	---------------------	-------------	-------

# 1. SYSTEM PROTOTYPE DEVELOPMENT

According to Lee and Blenis (2007), virtual prototyping refers to the undertaking of product development in an artificial but interactive computer generated environment. In most cases the virtual tools utilised results in an interactive visual design process that identifies potential constraints in the early stages of the design process (Wahab *et al.*, 2009). During the design process various virtual prototyping tools were utilised, including CAD software and simulation software in order to evaluate the design prior to construction. In developing the prototype, it was important to consult the end users and clients throughout the research and development process. These consultations identified design problems associated with the current manually based design system. The design process was strengthened by concept sketches, specifications and detailed technical drawings as illustrated in Appendix A and Appendix B.

The following sections contain a summary of the design and development process for the individual components of the RFID based cattle handling system. As shown in Figure 1.1, the system includes a box shaped crush portion with an operator side catwalk, flow control system, identification/weigh box, sliding gates, restraining system, handler access gates and automated sorting system. The detailed design drawings of the different components are illustrated in the Appendix A and Appendix B.

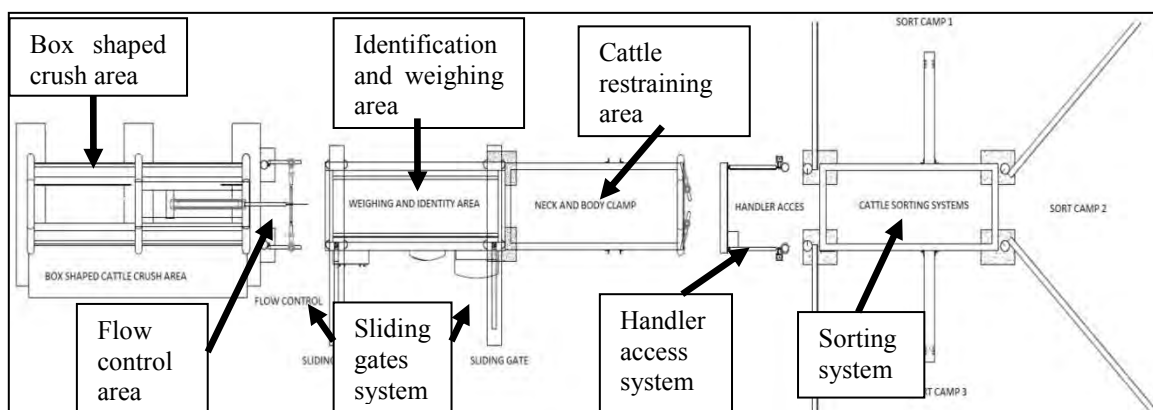

Figure 1.1 Schematic diagram of the RFID based cattle handling system

## 1.1 Box Shaped Cattle Crush Design

A box shaped cattle crush, also referred to as a cattle alleyway, serves the purpose of guiding the cattle in a single file, in their transition from the receiving area to the flow control and handling sections.

The following sections summarises problems with the existing manually operated systems and proposed solutions.

### 1.1.1 Design Problems in Existing Box Shaped Cattle Crush Systems

Table 1.1 contains some of the design problems highlighted by end users of the manual based system.

Table 1.1 Problems in the existing box shaped crush systems

ITEM NO.	DESIGN FACTOR	DESIGN PROBLEM
1	Unpredictable cattle behaviour in the crush	<ul style="list-style-type: none"><li>• May be caused by contrasting light levels in the crush design finish and colours</li></ul>
2	Cattle flow problems caused by wall design	<ul style="list-style-type: none"><li>• Uprights distracting flow</li><li>• Overlapping sheets causing harm to livestock</li><li>• Screw and sharp objects protrusions</li><li>• Cattle jumping outside crush passage</li></ul>
3	Cattle slip along passage	<ul style="list-style-type: none"><li>• Slip during handling</li><li>• Cattle lying down in passage</li><li>• Cattle turning</li></ul>
4	Slope along crush affecting flow	<ul style="list-style-type: none"><li>• Poor drainage and dung removal systems</li></ul>
5	Bruises and leg injuries	<ul style="list-style-type: none"><li>• Sharp angled corners causing injuries</li><li>• Gap between floor and wall too big/small</li><li>• Legs being trapped in gaps</li></ul>
6	Race dimension affecting flow	<ul style="list-style-type: none"><li>• Passage allowing cattle to turn</li><li>• Areas of passage too narrow for cattle flow</li></ul>



### 1.1.2 Final Specifications and Detailed Design

Based on information derived from the literature contained in Smith *et al* (2009) and design computations to select the best alternative, solutions for the design problems listed in Table 1.1 are summarised in Table 1.2 to Table 1.7 and detailed below.

To enhance the flow of cattle, a uniform environment in a cattle handling system must be provided. High contrasts in cattle handling operations increases the anxiety levels in cattle by more than 20 % (Grandin, 1989).

The South African Bureau of Standards developed a series of standards that guide the application and levels of galvanisation for cattle infrastructure in SABS 763 (SABS, 2010a) and SANS 121 (SABS, 2010b) which was derived from the ISO 1461 standard (ISO, 1999a; ISO, 1999b). The coating quality of hot dip galvanising for animal products that would be exposed to climatic condition in South African conditions are specified on the SABS Standards (2010e) and SABS Standards (2010f) as category A1-A2 which falls in the range 55-25µm.

Table 1.2 contains the final specification derived from literature on the contrasting level design specification in cattle infrastructure design.

Table 1.2 Contrasting level design specification

ITEM NO.	DESIGN SPECIFICATIONS
1	<ul style="list-style-type: none"><li>All steelwork to be of uniform colour texture and level to avoid stark contrast and to be galvanised primed to SABS 763/ SANS121/ ISO1461.</li><li>Coating quality minimum A1-A3 (55-25 micro meters)</li></ul>

It is important that the uprights of the crush walls are constructed on the outside and wall panels on the cattle flow side as experience has shown that having uprights on the cattle side increased the chances of injuries and resistance to cattle flow (Vowles, 1982). The idea proposed by Schoonover *et al.* (2001), cited by SACO (2010), requires that overlapping sheets should be in the direction of cattle flow to reduce the possibility of injuries to the animal, was adopted in this study.

In order to avoid sharp edges at the top and bottom of the internal wall panel it is necessary to have the sheets curved over at the top and bottom to prevent injuries. In addition, all screws and fasteners should be countersunk to avoid bruises and injuries and cattle panel walls should be constructed to a height of 1.5 m for uniformity (NMR, 2010).

Although there are different schools of thoughts in terms of the characteristics of the panel wall (Vowles and Hollier, 1982b), it is advisable to make use of solid panels for crush walls to minimise outside visual disturbances and reduce the risk of cattle jumping out of the crush.

Table 1.3 contains the recommended specification derived from the synthesis of the above literature and more design details are contained in Appendix A and Appendix B.

Table 1.3 Design specification for crush wall design

ITEM NO.	DESIGN SPECIFICATIONS
2	<ul style="list-style-type: none"> <li>• Uprights to be constructed on the outside and wall panels on the cattle side</li> <li>• Overlapping sheets to be in the direction of cattle flow</li> <li>• Sheets to be curved over along top and bottom to prevent injuries</li> <li>• All screws and fasteners to be countersunk to avoid bruises and injuries</li> <li>• Cattle panel walls to be constructed to a height of 1.5 m above ground level of cattle floor level</li> <li>• Use solid panels for crush walls to minimise outside visual disturbances and reduce risk of cattle jumping out the crush</li> </ul>

Floor surface specification is also another area of contention in terms of cattle facilities as different scholars have different views of how the floor surface has to be constructed (Vowles *et al.*, 1984a). Cattle floors slopes are generally to be constructed with a longitudinal slope of approximately 4% for drainage reasons (Vowles *et al.*, 1984b).

In some cases the longitudinal slope is dependent on the location of the infrastructure and whether the structure is under a closed roof, where drainage is not an issue, or external and exposed to the elements (Maton *et al.*, 1985). In this study, the infrastructure is intended for external environments and drainage needs to be taken into account. For areas that receive moderate rainfalls of about 600-800mm per annum, it is recommended that the floor be constructed of 25 mm deep grooves arranged in 200 mm diamond and square pattern to avoid

slip (Vowles, 1982). Table 1.4 contains the final specification of the floor surface design.

Table 1.4 Design specification of the floor surface in the crush

ITEM NO.	Floor Surface Design
3	<ul style="list-style-type: none"> <li>• Slope to be constructed with a general longitudinal slope of approx. 4%</li> <li>• Use 25 mm deep grooves arranged 200 mm diamond and square pattern to avoid slip</li> </ul>

Avoiding sharp angled corners to reduce injuries and using corners with smooth round posts or poles that aid flow is recommended by many researchers (Marshall, 1977). There is also a need to have a gap of between 80 -100 mm between floor and wall bottom for drainage and dung removal. These specifications are stipulated in the Government Gazette (2010) as a recommendation to minimise injuries as specified in Table 1.5.

Table 1.5 Design specifications to avoid bruises and injuries

ITEM NO.	Avoidance of Bruises and Leg Injuries
4	<ul style="list-style-type: none"> <li>• All uprights and poles to be rounded and smoothed to avoid injuries</li> <li>• Allow a maximum of 100 mm gap between crush wall and cattle floor for drainage but avoiding cattle injuries from having feet trapped in gap</li> </ul>

Referring to Appendix A which contains the design computations, assuming a crush of 430 mm wide at the bottom and 900 mm at top of the wall, a 500 kg average animal weight of between 1.5 - 2.5 m long would apply a force of 2 kN to the wall at approximately 1100 – 1200 mm above ground, which is roughly two thirds of the cattle height. Using standard tables (SABS, 2010c), computations showed that using 100 mm diameter planted posts and 50 mm stranding poles spaced at 3000 mm and 380 mm centre to centre respectively, translates to a resistance of 0.6 kN load and a bending moment of 11 kNm. A safety factor of 1.3 was used in the design process and a 30 MPa concrete mix for all concrete works was assumed. Table 1.6 contains the final specification for the boxed shaped crush. It was also further recommended to make use of the box crush orientation for structural stability as it is the most capable for resisting both tensional and compressive stresses associated with cattle facilities, an idea also supported by Longhorn (2010). The detailed assumptions and design

calculations are contained in Appendix A.

Table 1.6 Race dimension and shape

ITEM NO.	DESIGN SPECIFICATION
5	<ul style="list-style-type: none"> <li>• Use SABS 657 100 mm diameter structural round tube of wall thickness minimum 3.5 mm, with unit weight of 8.5kg/m for all planted posts and wall support boxes</li> <li>• Use a box shaped crush orientation illustrated in Appendix A of the design notes for stability</li> <li>• Safety factor of 1.3</li> </ul>

Further design computations contained in Appendix A were undertaken to determine the characteristics of the catwalk/platform on the box shaped crush side. It is found that 50 mm square tubing is an appropriate size for the support frame and 40 mm square tubing for the base frames. Table 1.7 contains the detailed specifications obtainable from the ISO, SANS and SABS design standards for structural components (HDGASA, 2010).

Table 1.7 Catwalk platform design

ITEM NO.	DESIGN SPECIFICATION
6	<ul style="list-style-type: none"> <li>• Use SABS 190-1&amp;2 standard expanded metal for all catwalks(standard, SWM-1.5;LWM-4.0; of 4.5 kg/m<sup>2</sup>) supported by 38 mm x 38 mm square tubing base frames on 50 mm x 50 mm square tubing with four supports per each 1.5 m portion of side crush to aid ergonomically friendly management practice (SANS Standards, 2010)</li> </ul>

Figure 1.2 is a pictorial sketch of the designed box shaped crush. Detailed design drawings, specifications and construction procedures are contained in Appendices A and B. Appendix A contains the detailed design notes and Appendix B contains a detailed drawing, specification document, material list and construction procedure document of the boxed shaped crush. It also contains a virtual prototype of the proposed box shaped crush assembly for design visualisation by the client and end users.

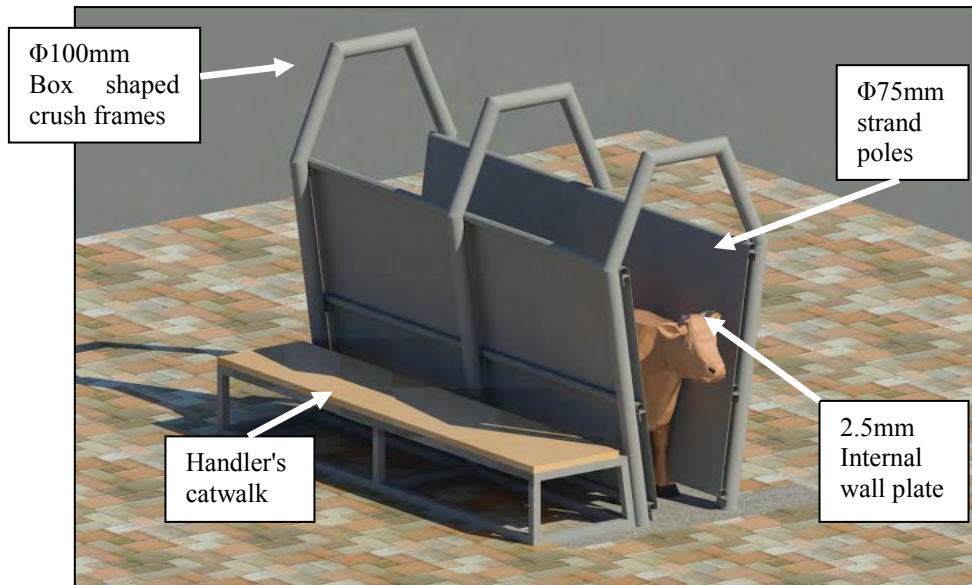

Figure 1.2 Pictorial view of the proposed box shaped crush

## 1.2 Cattle Flow Control Design

Cattle flow control is of importance to ensure smooth flow of operations in a handling system. This section provides details of the flow control requirements, recommendation and designs.

### 1.2.1 Design Problems in the Existing Manual Systems

Table 1.8 contain a summary of the problems encountered with current manual flow control systems, as summarised in CIGR (1984), CIGR (1992) and CIGR (1994) animal housing reports and also confirmed by Bowling *et al.* (2008).

Table 1.8 Problems associated with existing cattle flow control systems

ITEM NO.	DESIGN PROBLEM DETAILS
1	<ul style="list-style-type: none"> <li>Uncontrollable cattle flow towards the identification and weighing system</li> </ul>
2	<ul style="list-style-type: none"> <li>Stressful operations (opening and closing of gates manually)</li> </ul>
3	<ul style="list-style-type: none"> <li>Noisy gates operations</li> </ul>
4	<ul style="list-style-type: none"> <li>Injuries to animal when gate closes late</li> </ul>
5	<ul style="list-style-type: none"> <li>Flow speed regulation and individual animal control problems</li> </ul>

## 1.2.2 Design Solutions

Table 1.9 and Figure 1.3 contain the design solutions to the design problems listed, based on literature surveys and design computations to select the best alternative.

In order to have better animal control along the crush, it is important to have a flow control system at the mouth of the box shaped crush for regulation of movement. It was concluded that a combination of split gates and sliding gates resulted in improved practice assuming an animal speed of 1-2 m.s<sup>-1</sup>. Automation results in both quicker and more accurate handling and easier integration with other tasks. Table 1.9 and Table 1.10 contains the synthesised specification of the design which indicates the proposed solutions to uncontrollable cattle flow, stressful and noisy gate operations and speed regulation whilst minimising injuries to the animals.

Table 1.9 Design specifications for cattle flow control and speed regulation system

ITEM NO.	DESIGN SPECIFICATION
1	<ul style="list-style-type: none"><li>• Make use of a double split flow control gates</li><li>• Make use of sliding gates for anti-backing system in identification and weigh box and restraining system</li></ul>

Mechanical, electrical, pneumatic, hydraulic and electronic actuated automation systems were considered as possible alternatives. Pneumatic actuated automation was selected and Appendix A and Appendix B contain the selection considerations used in the design process. Standardised compressed air RAMS were recommended by many experts in the automation field due to their flexibility and ease of operations (Racewell, 2010). The standard ISO 6431 type DNC/DKE supplied locally by Festo (2010) was found to be the most appropriate system to use in this kind of operations (McCaull, 2011). Table 1.10 contains the final specification of the gate automation. The detailed selection process is illustrated and contained in Appendix A.

Table 1.10 Design specification for gate automation

ITEM NO.	DESIGN SPECIFICATION
2	<ul style="list-style-type: none"> <li>• Install an automated flow control system powered by automated compressed air rams for both double split gates and sliding gates</li> <li>• Selection from ISO6431 Type DNC/DKE Compressed air RAMS</li> </ul>

Figure 1.3 is a pictorial sketch of the developed flow control double split gates. Details of the design drawings, specification, construction procedures and virtual prototype are contained in Appendix A and Appendix B contains a detailed drawing, specification document, material list and construction procedure for the flow control double split gates.

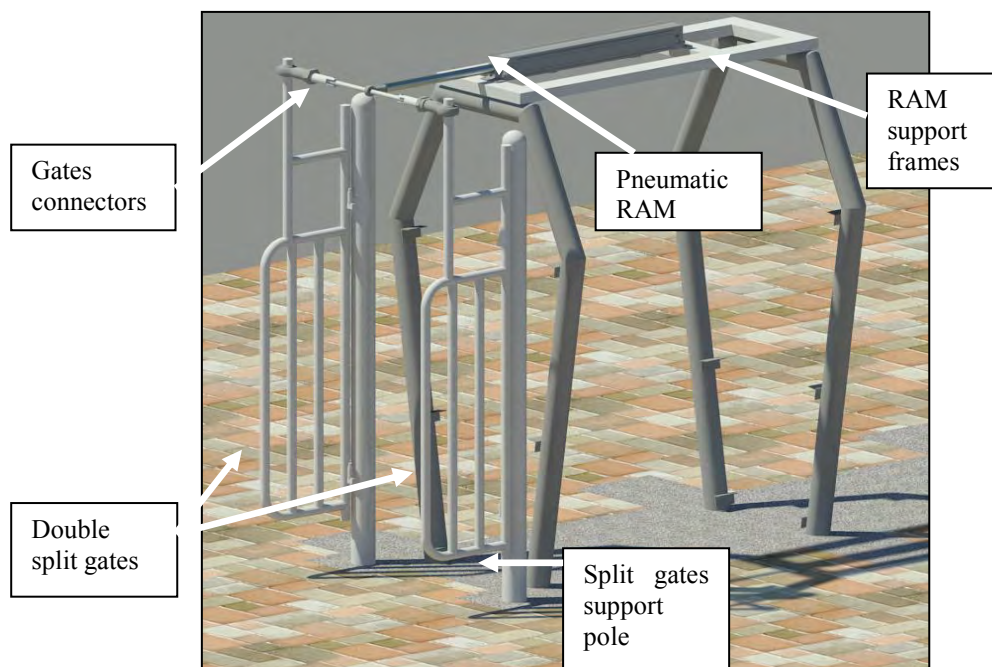

Figure 1.3 Flow control double split gates

### 1.3 Cattle Sliding Gates System Design

These gates serve the purpose of restricting flow and anti-backing of cattle movements and enhance flow patterns and smooth operations. This section provides detail designs of the gates system.

### 1.3.1 Design Problems in the Existing Manual Systems

Table 1.11 contains a list of the sliding gate system design problem areas and details which Britz (2010) highlighted and which were obtained from the research undertaken by the ARC-IAE (Mutenje, 2009).

Table 1.11 Problems associated with design of cattle sliding gates

ITEM NO	DESIGN PROBLEM DETAILS
1	• Non uniform alley control system
2	• No proper anti-backing, blocking and baulking
3	• Limited alley space for swing gate in the system
4	• Labour intensive gate operation procedures
5	• Long walking distance when opening and closing the gate
6	• Less cost effective systems requiring review
7	• Inefficient labour utilisation

### 1.3.2 Design and Final Specifications

A sliding gate system is the most widely used system for closing and opening narrow cattle lanes or races (Grandin, 1993). The functions of the sliding gates are to block and to limit baulking and back tracking. A sliding gate system is typically used in places where there is limited room and where a traditional swing gate would pose an obstruction in its open position.

There are three main actuator types of sliding gates that can be utilised, i.e. manually operated, pneumatic gates (single unit) and pneumatic split gates (double leaf). Due to cost restrictions and effectiveness of operations, a pneumatic gate system was selected for this system.

Compressed air RAMS supplied by Festos (2010), incorporated with automation control systems from Omron (2010), were utilised in this project. This information was also verified by computations as detailed in Appendix A which also contains detailed solutions adopted for the above summarised problem. Table 1.12 contains the design solutions to the above mentioned design problems, extracted from Appendix A design notes.



Table 1.12 Design solution cattle flow control system

ITEM NO.	DESIGN SPECIFICATION
1	<ul style="list-style-type: none"> <li>• Make use of pneumatically controlled remote controlled or button controlled gate system which required less effort from the operator and hence less human power requirements</li> <li>• Make use of two sliding gates system before and after ID and weigh box</li> <li>• Introduce compressed air rams to open and shut gates from the top</li> </ul>

Figure 1.4 shows a pictorial sketch of the design cattle sliding gates system. Details of the design drawings, specifications and construction procedure are contained in Appendix A and in Appendix B contains a detailed drawing, specification document, material list and construction procedure for the flow control double split gates.

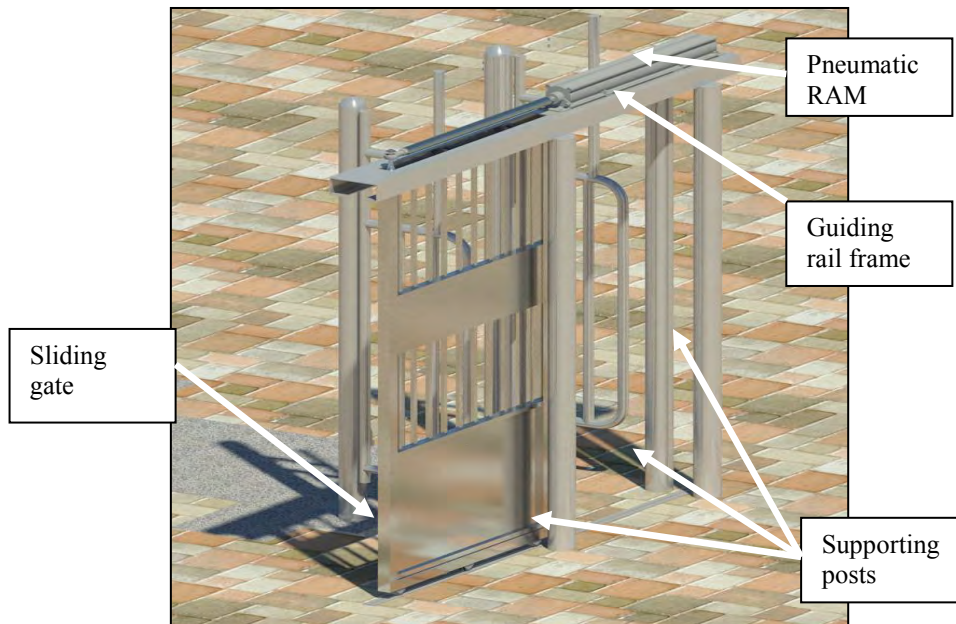

Figure 1.4 Cattle sliding gates system

The sliding gates are installed to act as boundaries of the identification and weigh box both at prior and system exit. The components that require design consideration include the identification and weigh box.

#### 1.4 Identification and Weigh Box Design

This is the most important section of cattle handling where the animal is identified and animal specific data is captured. If the operation is undertaken incorrectly, it might result in

poor management practices and result in a waste of resources. Appendix A contains a detailed design report of these systems.

#### 1.4.1 Design Problems in the Existing Manual Systems

The Table 1.13 contains a list of problems in the identification of animals and weigh box currently experienced with manually operated systems.

Table 1.13 Problems in animal identification and design of the weigh box

ITEM NO	DESIGN PROBLEM DETAILS
1	<ul style="list-style-type: none"> <li>• In correct cattle identification</li> </ul>
2	<ul style="list-style-type: none"> <li>• Long period required to identify cattle</li> </ul>
3	<ul style="list-style-type: none"> <li>• Incorrect cattle weighing system</li> </ul>
4	<ul style="list-style-type: none"> <li>• Long periods required to weigh animal</li> </ul>
5	<ul style="list-style-type: none"> <li>• Unsafe cattle platforms</li> </ul>
6	<ul style="list-style-type: none"> <li>• Inhumane cattle handling system</li> </ul>
7	<ul style="list-style-type: none"> <li>• Inefficient cattle identification and weighing systems</li> </ul>

#### 1.4.2 Detailed Design and Final Specifications

Although RFID tags are a more efficient system for cattle identification, it is necessary to make use of visual tags in case of electronic failure. It is more advantageous to make use of panel readers for identification as compared to stick readers. From computations and experimentations reported, it was concluded that for efficient system flow it is necessary to make use of the 132.4 kHz frequency compliant weighing and display units.

In order to realise the benefits of electronic sorting and management system, management software should be incorporated.

The benefits of electronics can be negated by delays in the conveyance of an instruction to open or shut a gate. Although automation has advantages in management practices, it is necessary to investigate the financial and logistical challenges associated with these systems.

Table 1.14 contains the design solutions of the identification and weighing system, with more details in Appendix A and Appendix B.

Table 1.14 Design specifications for ID and weighing system

Item No.	Design Specifications
1	<ul style="list-style-type: none"> <li>• Make use of RFID tags together with visual tags as identifiers</li> <li>• Use panel readers for identification system</li> <li>• Electronic scales which are compatible with RFID systems and with electronic reading units</li> <li>• Use weigh indicators and software for data management and transfers</li> <li>• Use weight based sorting criteria for decision making</li> </ul>

Figure 1.5 is a rendered image of the designed identification and weighing system. Details of the design calculations, drawings, specifications and construction procedure are contained in Appendix A and in Appendix B contains a detailed drawing, specification document, material list and construction procedure for the cattle identification and weigh box.

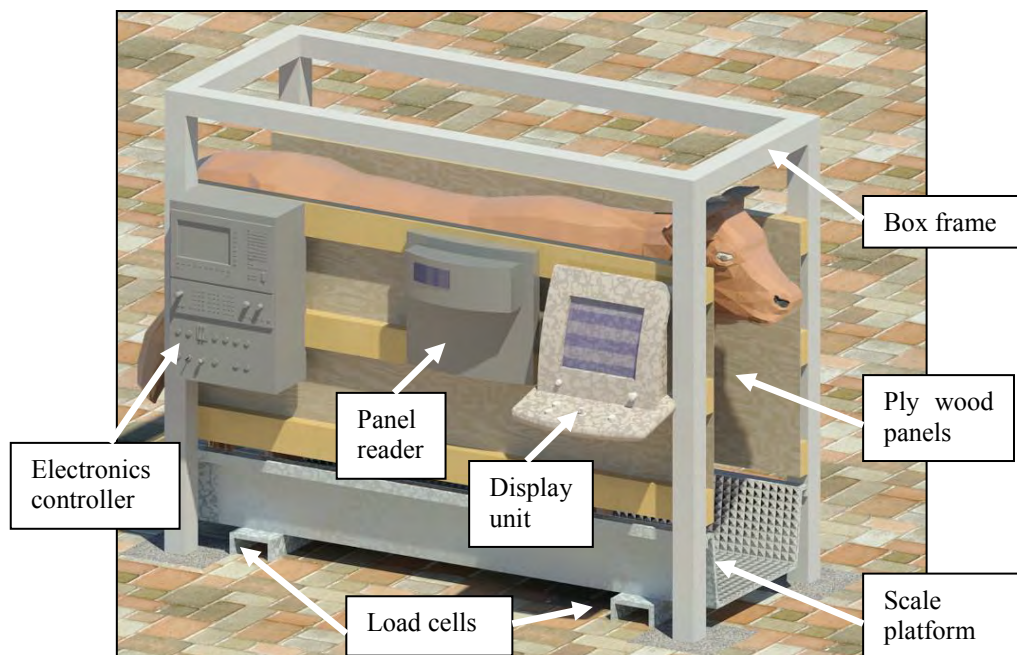

Figure 1.5 Cattle identification and weigh box

## 1.5 Cattle Restraining System Selection

Cattle restraining mechanism can generally be described as side frames between which cattle are driven and both neck and body are caught for working purposes. This system enables working on an animal in its upright position. Crushes normally are approximately 2 m long, 2

m high with 0.7 m as minimum width.

### 1.5.1 Design Problems in the Existing Manual Systems

Table 1.15 contains the design problem areas and details associated with cattle restraining system sometimes referred to as a neck and body clamp.

Table 1.15 Design problem associated with cattle restraining system

ITEM NO	DESIGN PROBLEM DETAILS
1	• Cattle discomfort during operations
2	• Noisy operation procedures
3	• Inadequate anti-backing systems
4	• Poor floor designs
5	• Strenuous operations procedures
6	• Restrictions in cattle flow

### 1.5.2 Selection Criteria for the Restraining System

Although the restraining system was not part of the design process, it was selected based on the desired characteristics to ensure ethical management systems. These characteristics include more efficient operated restrainers.

A walk-through head bail at the mouth of the system to enable clamping of the animal at system exit is required.

There should be a full height gate at the rear of restrainers as an anti-backing system. It is of paramount importance to have at least a 3 mm plate, welded or bolted in as platform, for efficient cattle flow.

These ideas are contained in the Taltec (2010) neck and body clamp characteristics brochure and manuals. Table 1.16 and Figure 1.6 contain the required characteristics of cattle restraining system.

Table 1.16 Design specification for the cattle restraining system

1	Restraining System from literature, selections and design computations
Selection Criterion	<ul style="list-style-type: none"> <li>• Near side and off-side operations</li> <li>• Walk through head bail (V-opening)</li> <li>• Mechanical head bail locking system with no ratchet noise</li> <li>• Head bail operation from front and rear of crush</li> <li>• Full height gate on non-operating side</li> <li>• Ratchet push up bars</li> <li>• Floor – 3mm checker plate, welded or bolted in</li> <li>• Heavy duty slam latches</li> <li>• Drop away handles for safety</li> </ul>

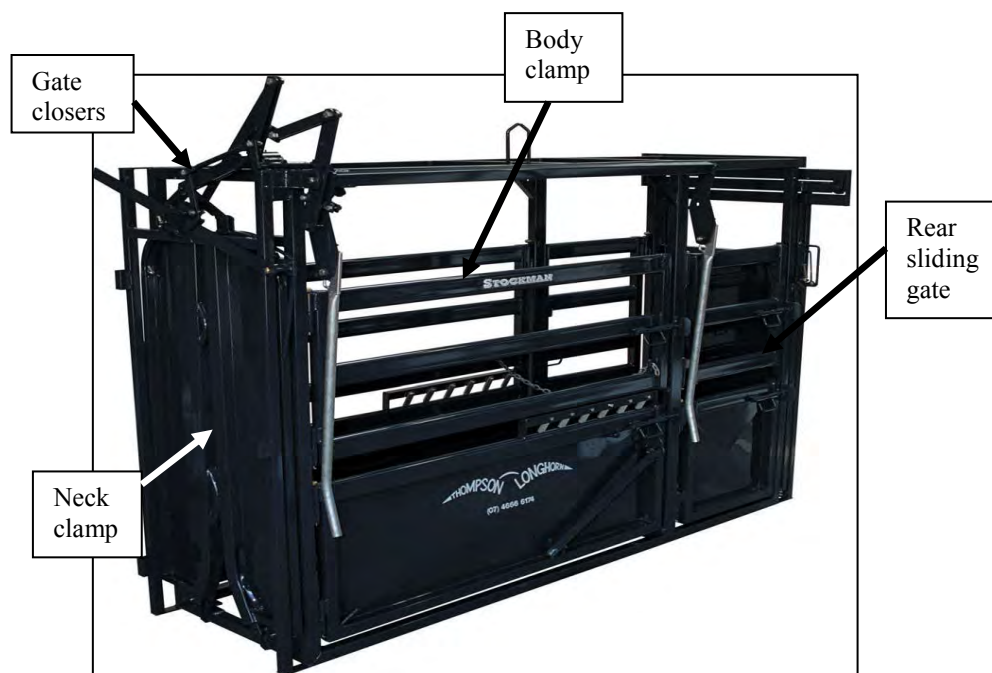

Figure 1.6 Pictorial view of a neck and body clamp (Longhorn, 2010)

### 1.6 Handler Access Gate Design

During the handling process at the restraining zone, it is importance to be able to manoeuvre from one side to the other side during operations. Access gates area act as a transition zone from the restraining to the sorting system. This section contains specifications for the handler access gates for adequate system performance.

### 1.6.1 Specification Requirements for the Handler Access Gates

Table 1.17 contains the specification and design requirements of the handler access gates. These requirements formed the basis for the design.

Table 1.17 Design specifications of the handler access gates

ITEM NO	DESIGN AND SPECIFICATION REQUIREMENTS
1	<ul style="list-style-type: none"><li>• Allow passage of handler between near and far side during handling of cattle</li></ul>
2	<ul style="list-style-type: none"><li>• Enables administering passage for cattle dosage</li></ul>
3	<ul style="list-style-type: none"><li>• Allows handler to safely manoeuvre in and out of the passage or cattle alleyway freely</li></ul>
4	<ul style="list-style-type: none"><li>• Channels cattle to the sorting system</li></ul>

### 1.6.2 Selection Consideration for the Handler Access Gates

Most of the operation in a cattle handling facility are undertaken on the right side of the animal direction, but the handler should have access from both sides. This passage not only serves as access to a handler, but also acts as a means of transferring all the handling equipment from one side to the other side. For efficient operation, the access gates passage should be at least 750 mm wide to allow items like computers and readers to be transferred from one side to the other side. From research undertaken it was established that gates should be at least 250 mm above the ground to avoid possible obstruction brought about by sagging as manure accumulates on the floor. A height of 1500 mm above ground for fencing was selected for uniformity of the handling structure. The side gates of the handler access are to be made of solid sheeted material to inhibit cattle from exiting through it.

The SABS (2010a) recommends making use of a water proof and anti-corrosion finish for the components as it is likely to be exposed to manure containing ammonia carried along by the animals.

Table 1.18 contains the design and specification of the handler access gates. Detailed specifications are shown in Figure 1.7, Appendix A and Appendix B.

Table 1.18 Specification of the handler access gates system

1	<b>Handler Access gates System from literature, selections and design computations</b>
<b>Selection Criterion</b>	<ul style="list-style-type: none"> <li>• Access gates inter side passage to be at least 750 mm wide to allow items like computers and readers to be transferred from the far side to near side</li> <li>• Gates to be at least 250 mm from the ground to avoid sag effects</li> <li>• Top level to be 1500 mm above ground for uniformity with whole cattle side fences</li> <li>• Solid sheeted to inhibit cattle from exiting through it</li> </ul>

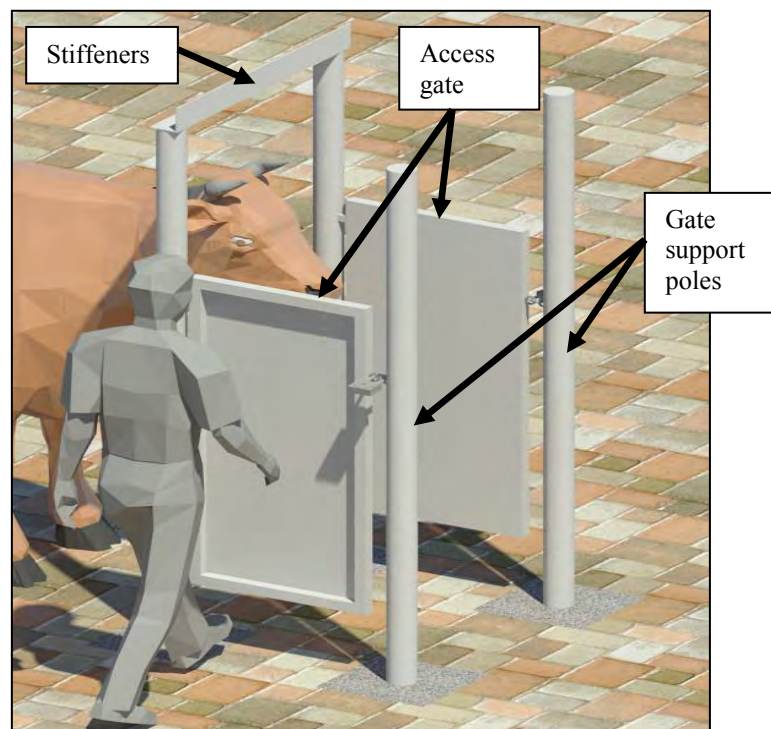

Figure 1.7 Rendered drawing of the handler access gates

### 1.7 Automated Cattle Sorting System Design

After cattle restraining has been done and a management decision has been made, the animal is then moved to the sorting system. The automated sorting system is at the centre of cattle handling as it serves to translate all the handling practise of the entire system into tangible results. In this section animals are sort based on the management decision and data obtained throughout the system.

The system serves great purpose on translation of management decision into action. This section contains specification requirements for the automated sorting system for adequate system performance.

### 1.7.1 Specification Requirements for the Cattle Sorting System

Table 1.19 contains the specification and design requirements of the cattle sorting system.

Table 1.19 Design specification requirements of the cattle sorting system

ITEM NO	DESIGN AND SPECIFICATION REQUIREMENTS
1	<ul style="list-style-type: none"> <li>• Allow lane drafting of cattle</li> </ul>
2	<ul style="list-style-type: none"> <li>• Low stress handling system</li> </ul>
3	<ul style="list-style-type: none"> <li>• Automated and Pneumatic controlled system</li> </ul>
4	<ul style="list-style-type: none"> <li>• Sorting of cattle on weight basis</li> </ul>
5	<ul style="list-style-type: none"> <li>• Sorting of cattle in three camps</li> </ul>
6	<ul style="list-style-type: none"> <li>• Hand-held remote controlled system or computer based sorting</li> </ul>

### 1.7.2 Selection Consideration and Computations

For an efficient system, a system was developed to incorporate state of the art technology that supports selective sorting of animals for various management systems. Markets currently pay premium prices for animals within a particular weight range. The sorting system must be able to achieve sorting into three basic camps as ready for market, almost ready and still requiring constant feeding and monitoring. This will enable forecasting output schedules as the feedlot operator would be able to give advance notice to the market as to when the next groups of animals will reach the target weight.

Sorting gates passages should be at least 850 mm wide for efficient cattle flow. The gates should be 1650 mm long and 1000 mm high as this allows free animal movement whilst limiting turning back. As manure is deposited on the floor, accumulations can impact on to gate operation and thus a clearance of 250 mm below gates in sorting systems is necessary. Design for withstanding of forces and stresses recommends that, it is advisable to make use of 100 mm square tubing support system for suspending the sorting system. The gates should be automated for both opening and closure as these gates are robust and are not easily



manually operated without causing a considerable amount of stress.

The use of management software and suitable weighing systems that are compatible with the desired system is advisable for efficient system operation. Gates can either be controlled from management software or by remote activation. Capabilities of Tru-test weigh-sort systems (sorting system supplied by Tru-test company from New Zealand) with regards to the system requirements can also be considered for system improvements. In ordinary cattle sorting systems, Challis (2010) recommends to make use of 4 kN thrust and retreat capable compressed air RAMS for gates controls. The same size range was confirmed by Omron (2010) for these kinds of operations. The gates should be 1500 mm high with a clearance of 250 mm above the ground.

Design specifications of the sorting systems are detailed in Table 1.20, Appendix A, Appendix B and Figure 1.8.

Table 1.20 Specification of the automated pneumatic controlled sorting system

1	<b>Cattle Sorting System from literature, selections and design computations</b>
<b>Selection Criterion</b>	<ul style="list-style-type: none"> <li>• Sorting gates passage to allow at least 850 mm alley for cattle passage</li> <li>• Sorting gates to be at least 1650 mm long and 1000 mm high</li> <li>• Sorting gates to have a clearance on 250 mm above floor</li> <li>• Sorting system to be fully suspended on 100 mm square tubing support system</li> <li>• Gates to be automated controlled by remote or instruction from cattle management software controlling compressed air rams</li> <li>• Use 4 kN thrust and retreat capable compressed air RAMS for gates controls</li> <li>• Gates to be at least 250 mm from the ground to avoid sag effects</li> <li>• Top level to be 1500 mm above ground for uniformity with whole cattle side fences</li> <li>• Solid sheeted to inhibit cattle from exiting through it</li> <li>• Make use of Pratley air and automation control systems as its outlet system easily confirms to the design standards of South African air and electronic cablings and tubing</li> </ul>

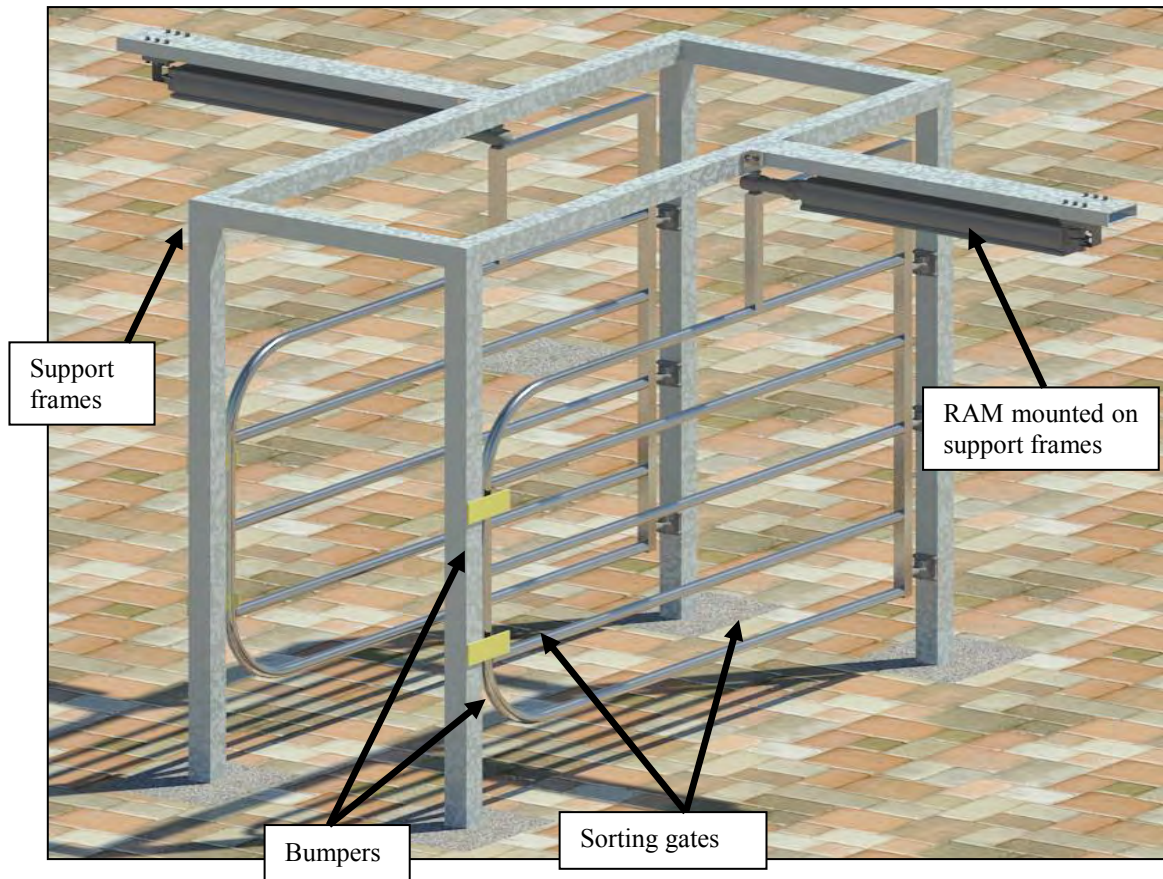

Figure 1.8 Automated pneumatic cattle sorting system

## 1.8 Proposed Complete System Development and Evaluation Procedure

The conceptual design phase was followed by a detail design and computation phase which resulted in virtual prototypes and final designs of the following cattle handling system components:

- the box shaped crush system,
- cattle flow control system (double split gates),
- automated cattle sliding gates system,
- cattle identification and weighing system,
- cattle restraining system (neck and body clamp),
- cattle handler access gates, and
- pneumatic controlled automated cattle sorting system.

Detailed prototypes and design data were produced for all the design areas. Appendices A and B contain the detailed designs and include the project funder's commentary on each

component.

## **1.9 Summary of the System Development Process and Way Forward**

Virtual engineering tools were utilised in the development of the RFID based cattle handling prototype system without physical modelling. This technological advancement facilitated the establishment of design challenges during the preliminary stages of prototype development. The design reports, contained in Appendices A and B, detail the standard design process followed in the development of the virtual prototype of the system.

With the aid of virtual tools the project funder was able to make informed decisions regarding the system outcomes in parallel with the design process and implementation procedure, which resulted in an end user acceptable virtual prototype ready for fabrication and construction.

It was found that the virtual prototypes resulted in the visualisation of the end product and made it easy to extract acceptable specification. In addition, it illustrated construction procedures that were easily read and interpreted by the project funder. All of the above enabled informed decision making on the material, financial, space requirements and construction duration. In his literature review and proposal, Mutenje (2009) estimated that the whole RFID based cattle handling system would require a capital cost of R 200 000, 110 man hours to construct, an area of 250 m<sup>2</sup> and a construction duration of approximately 12 weeks. The next chapter details the design modifications, fabrication, construction and evaluation process that was undertaken

## AUTOMATION AND PNEUMATIC SYSTEM DESIGN

A number of revisions were considered for the automation and electronics control systems. These were to enable the system to undertake auto-drafting (standard drafting and hold-then-draft) and bypass drafting (bypass many, bypass one and hold-then-override). The difference between standard drafting and hold-then drafting is that in the latter there is an option introduced in the command system where the operator can press a hold button to delay auto-drafting should there be an animal trapped in the system. The operator also has the capability to bypass the drafting process, should the animals entering into the system not be the required sample for handling. These enable override of the automated system in cases where certain procedures must be skipped or repeated. Thus, an animal may be required to remain in the system for more than the design period or exit system without handling.

Figure 0.1 and Figure 0.2 show the design principles considerations for the auto drafting, including both the standard and hold-then-draft, and Bypass drafting (many, one and override).

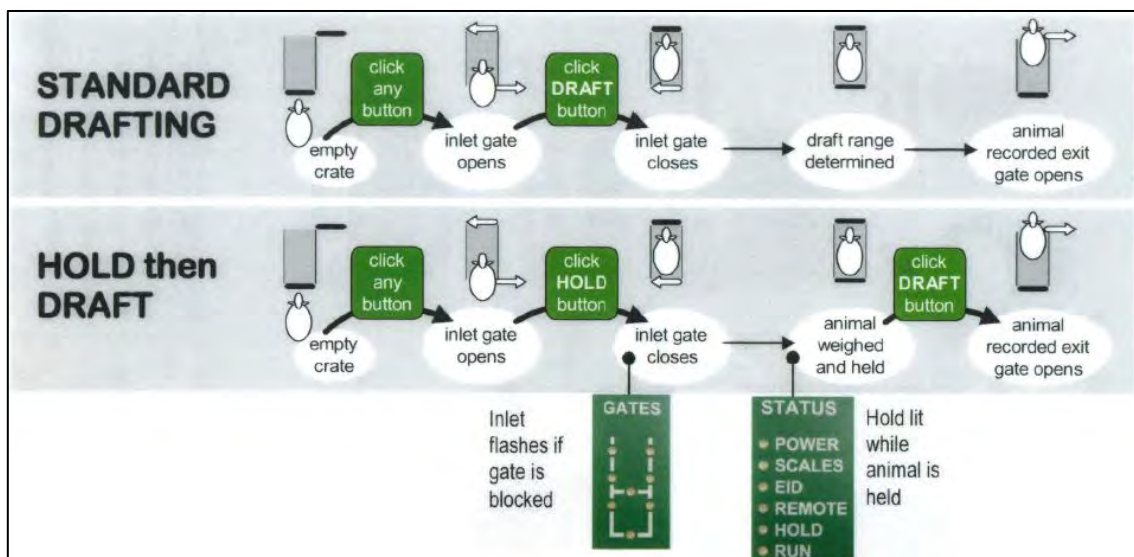

Figure 0.1 Drafting principles of operation by remote control

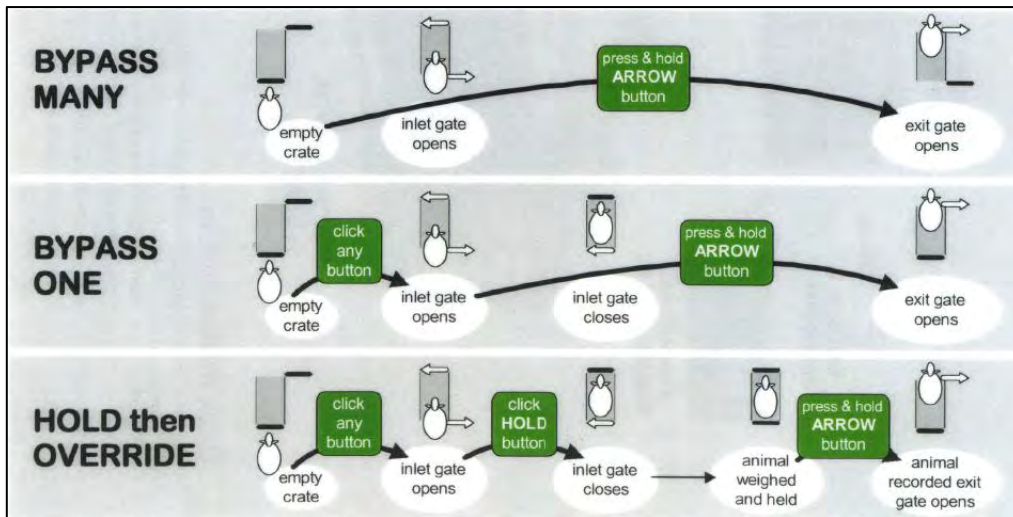

Figure 0.2 Bypass drafting principles of operation by remote control

In order to achieve the automation and air control an array of devices were designed, programmed, fabricated and assembled together. These included air supply systems, inlet gate switches, a pneumatic control box, an automation control box, radio remote controller, cabling, radio, and ID-weigh system, as illustrated in Figure 0.3.

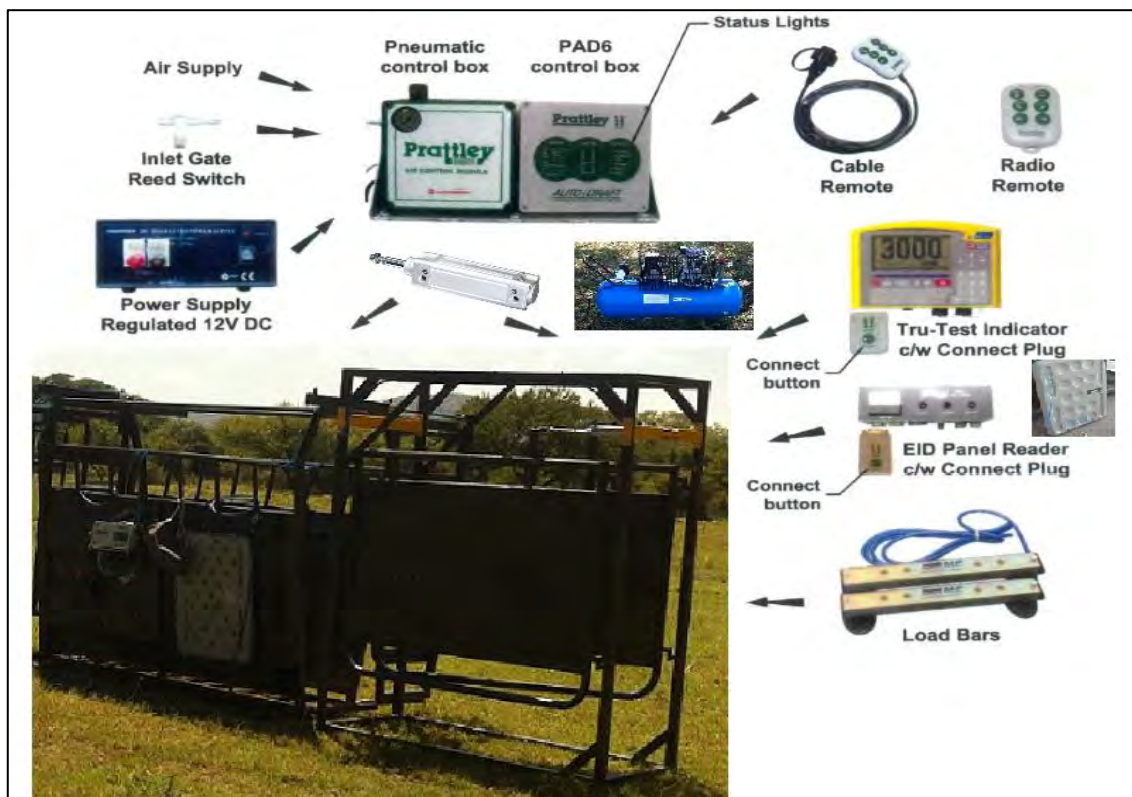

Figure 0.3 Automation and pneumatic control illustrations

To automate the system there was a need to develop the automation and pneumatic control system. Figure 0.4 and Figure 0.5 show the modified diagrams and illustrations of the air and electronics system configurations.

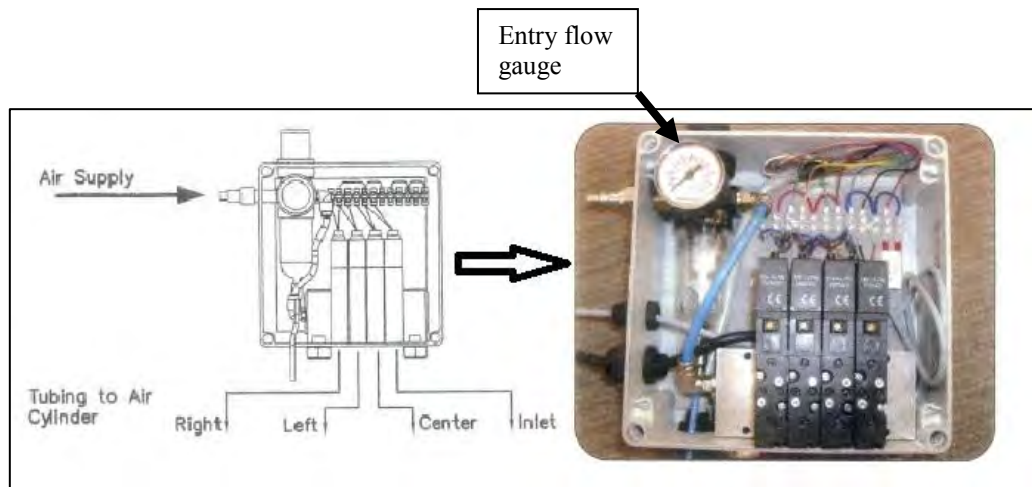

Figure 0.4 Pneumatic control box for automation

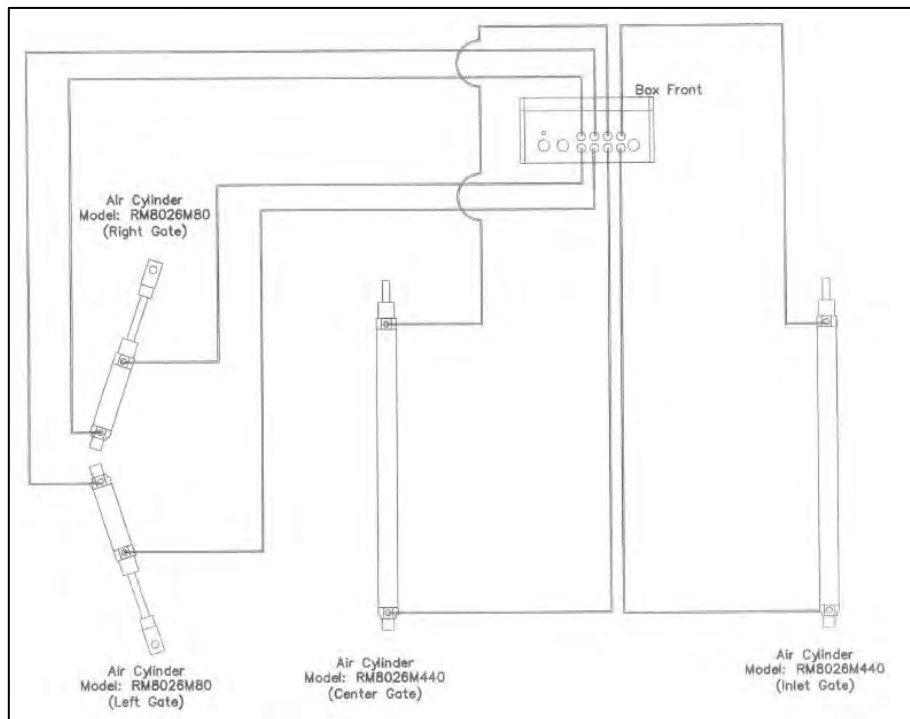

Figure 0.5 Automated pneumatic air cylinders arrangements for right hand entry

Figure 0.6 illustrates the air tube modification on the pneumatic valve box when fitting the new automated electronic control system with all crate resistors denoting the type of auto drafter.

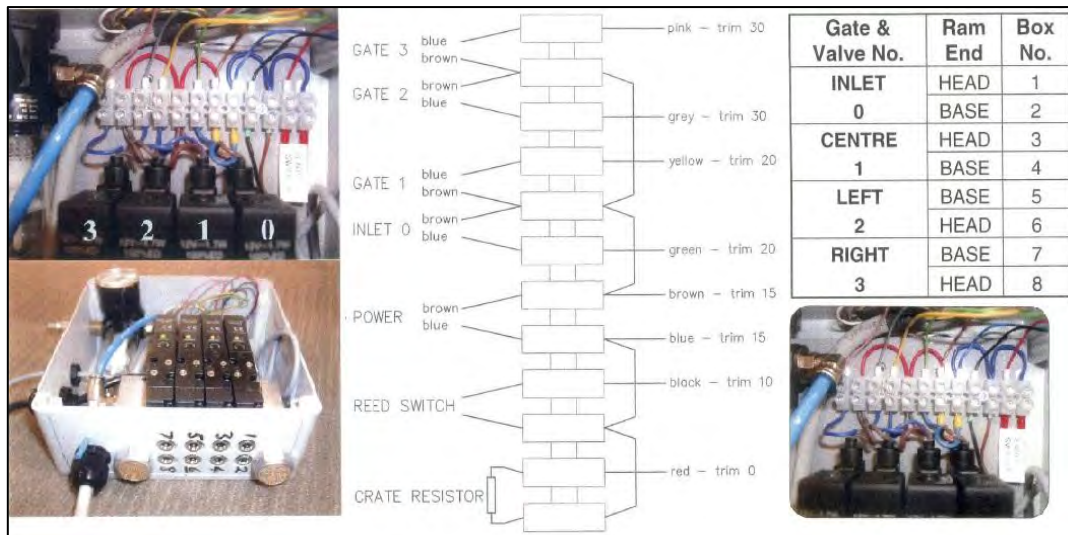

Figure 0.6 Combined automation electronics control systems

### 1.1.1 RFID System Equipment Layout

A dual mode Tru-Test XRP reader compliant with ISO cattle Half and Full duplex tags was utilised for the identification system (Challis, 2011). The system was designed for 134.2 KHz frequency operation with maximum a read distance of 1 m. The system was designed such that there is synchronisation and information passage between the antennae, reader and indicator as illustrated in the Figure 0.7.

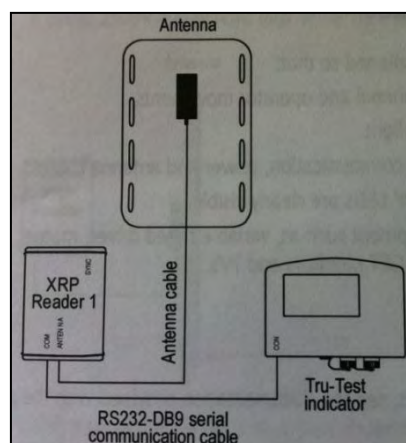

Figure 0.7 Reader connection to single antenna and indicator (Allflex, 2010)

Initial analysis indicated that some components need to be mounted on walls or placed away from the handling system for better management practices. A number of components were developed to serve such purposes and these included a mounting system for the XRP reader,

wall fasteners and separate stands, as illustrated in Figure 0.8.

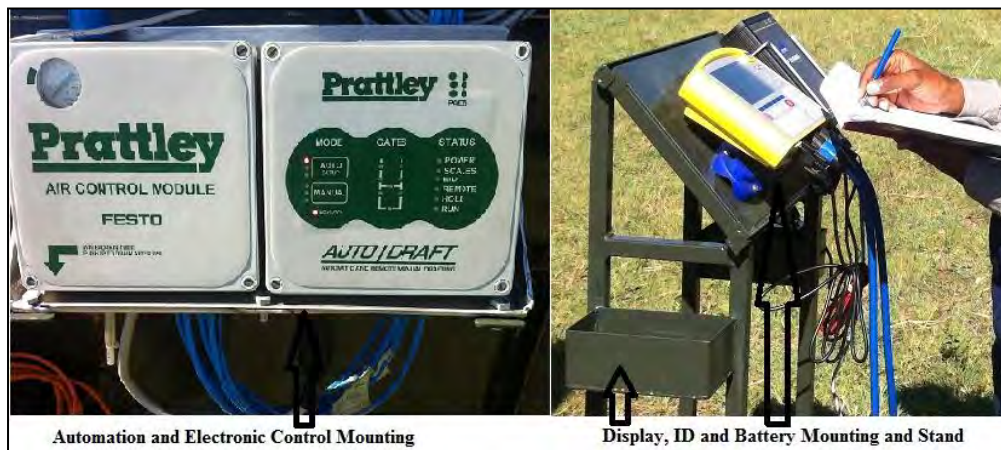
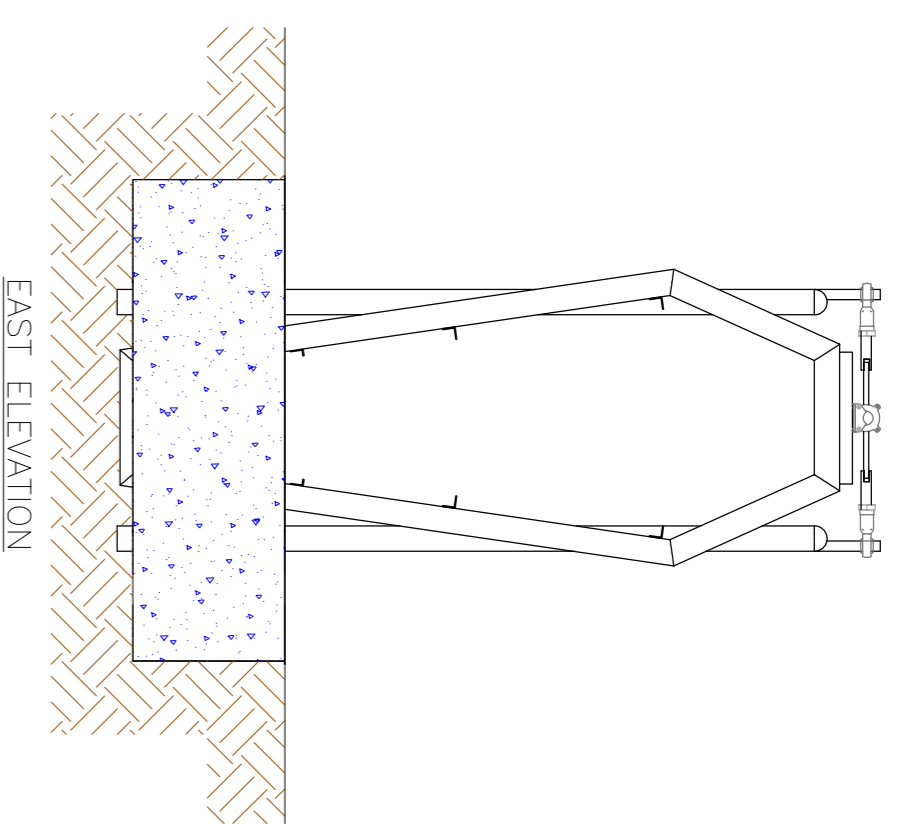
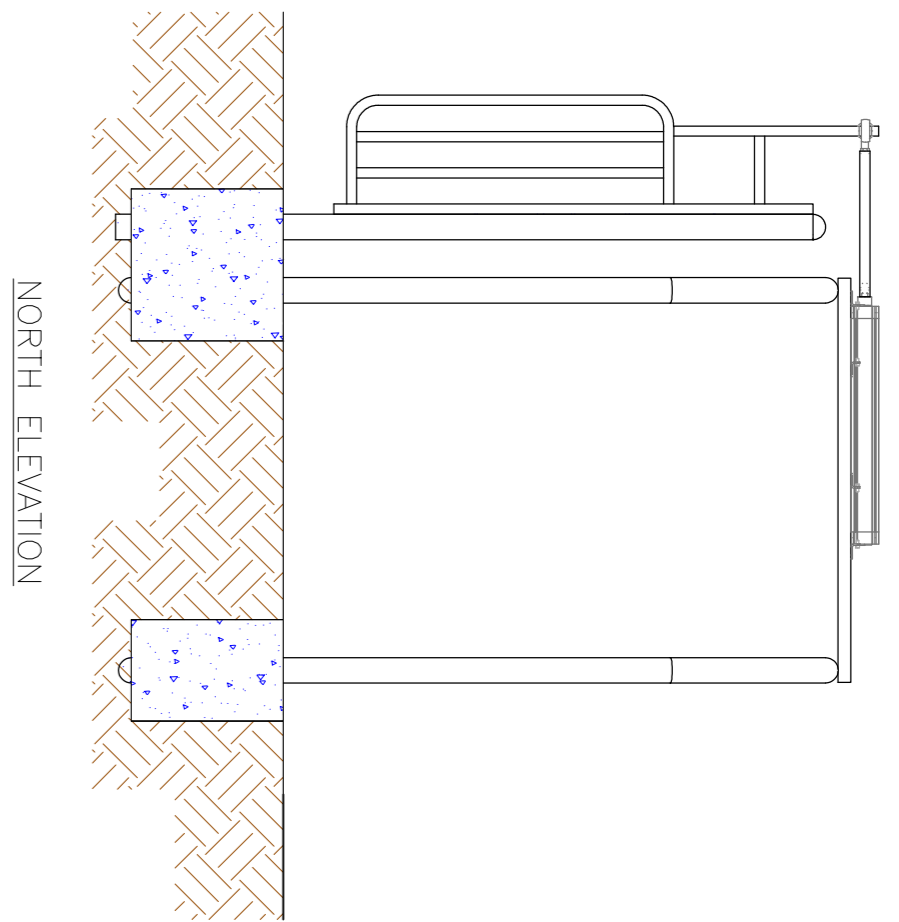
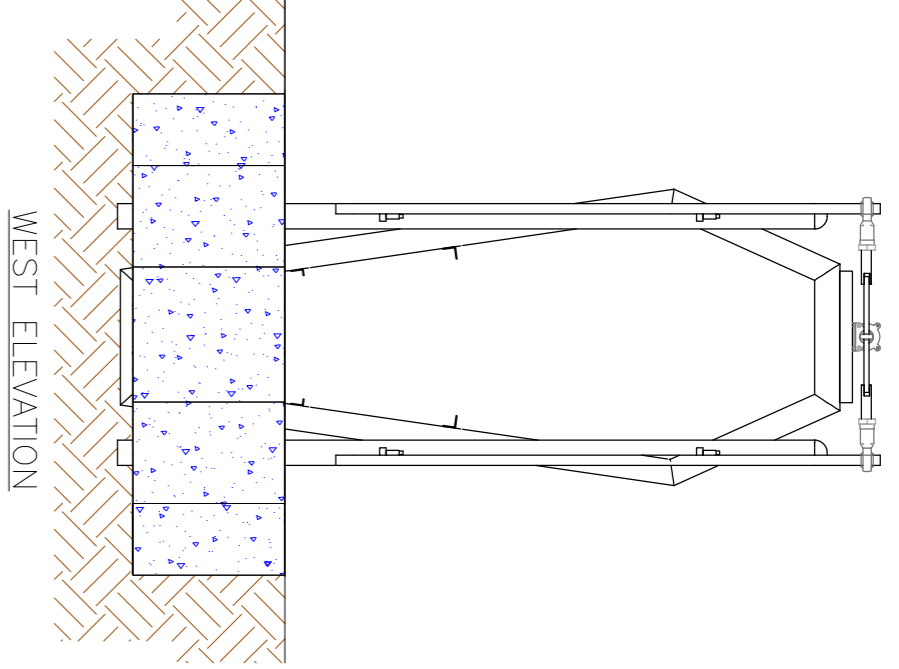

Figure 0.8 Mountings and stands for equipment







ELEVATIONS SCALE 1:30

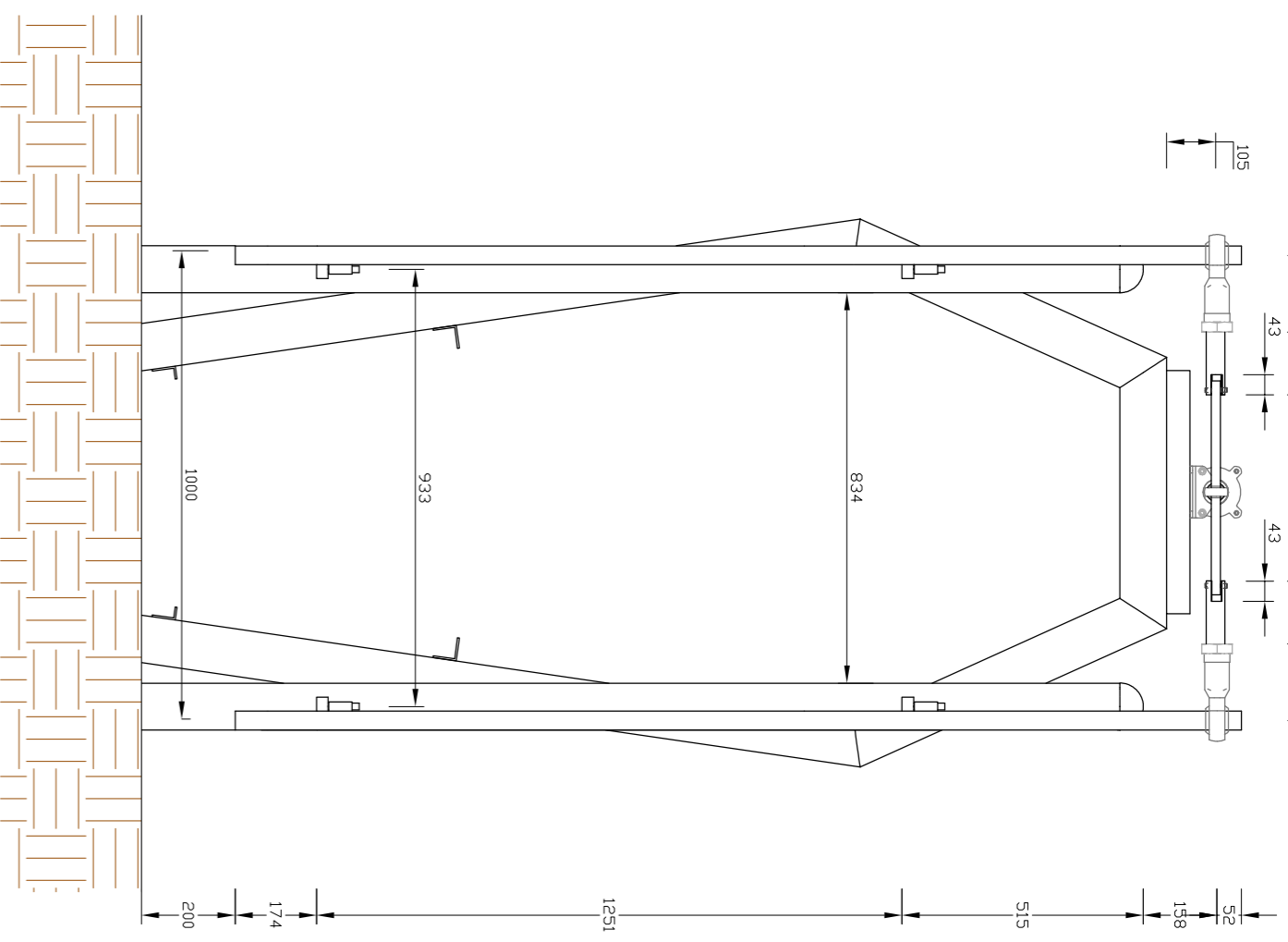

SECTION ACROSS GATES SCALE 1:15

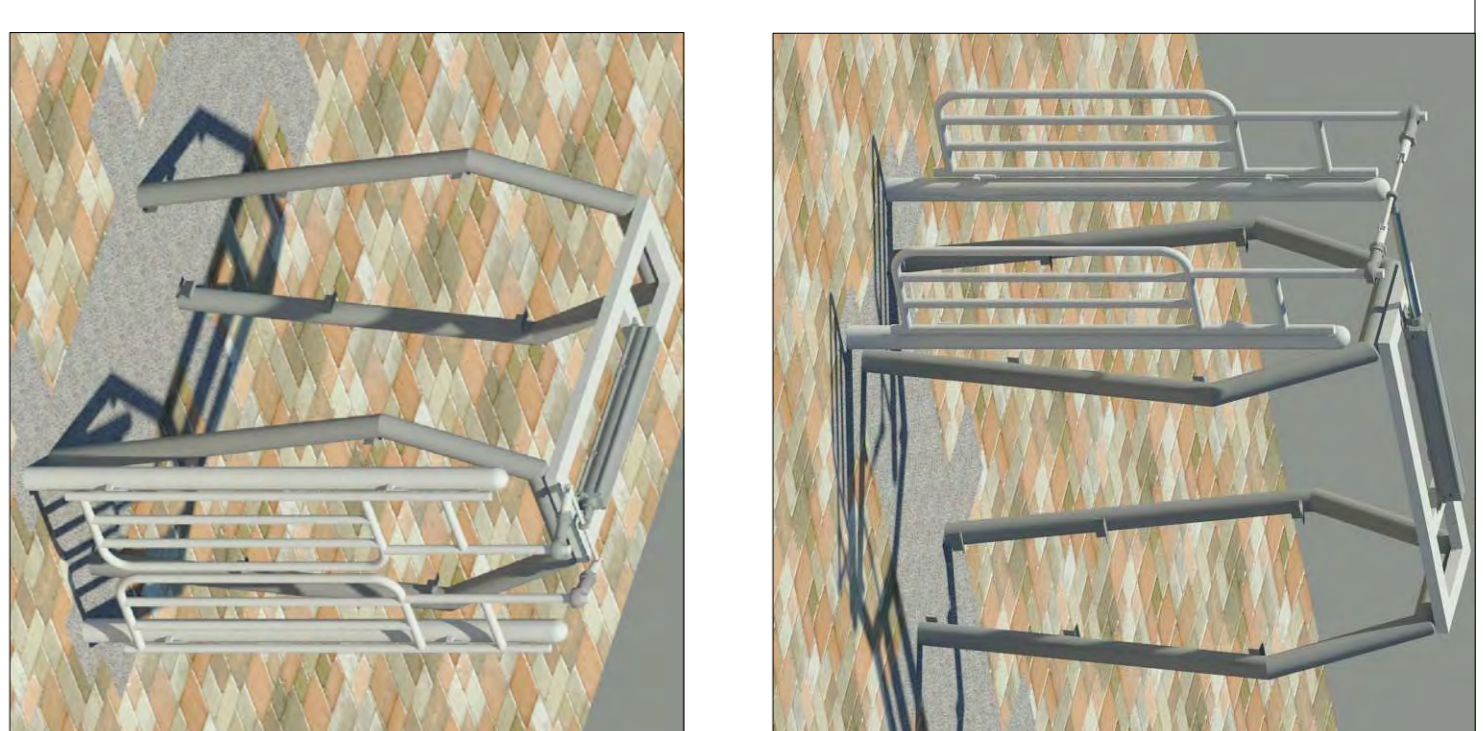

RENDERED VIEW OF SPLIT GATES SYSTEM

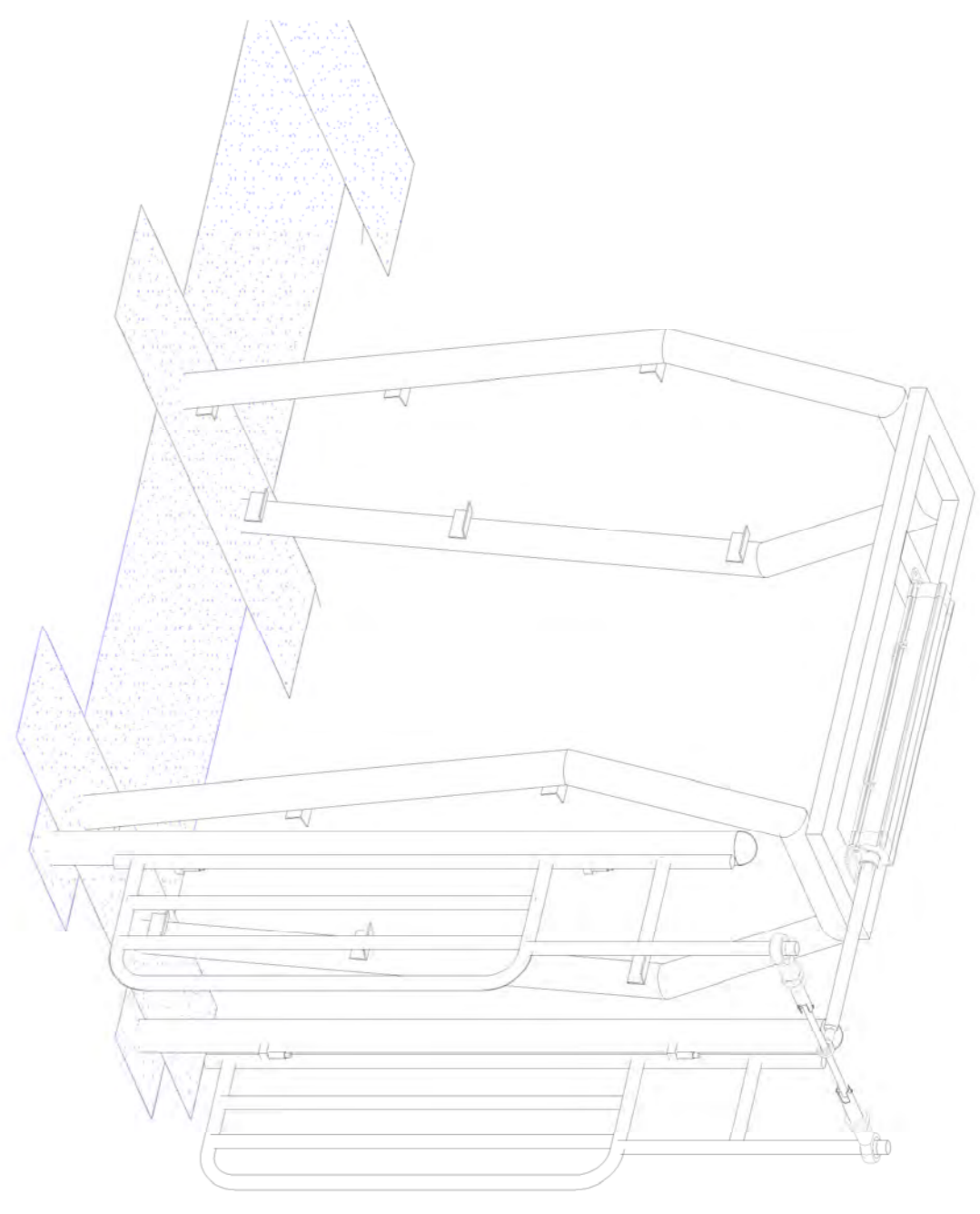

3D VIEW OF CATTLE FLOW SPLIT GATES Scale 1:20

**CATTLE FLOW CONTROL DOUBLE SPLIT GATE SYSTEMS**  
Construction Procedures

COMPONENT B

**SUBJECT:**

Construction Procedures for the Cattle Flow Control Split Gates

**COMPONENTS**

1. Support Posts
2. Pneumatic System
3. Extension Pole& eyes
4. Double Split Gates

**PURPOSE:**

Regulates flow of cattle towards the DD&Weight

**Box**

**PROJECT NUMBER:**

AI04/100

**DESIGN BY:**

Tenda Justin Muterne Agricultural Engineer

**PICTORIAL PROCEDURES:**

ITEM	DETAILED DESCRIPTION
1	Clear 100mm of top soil on the construction area and excavate for the 2 support planted post 400mm x 400mm x 600mm deep holes and compact until no further collapse.
2	Supply and install the 2 planted support posts in the excavated holes complete with the hinge mechanisms. (Details of the split gate assembly are specified in drawing no AI04/100/2.)
3	Cast concrete around the posts and temper to ground level as specified and illustrated in drawing no AI04/100/2. Cure concrete by wetting and keeping damp
4	Supply and Place the Double Split gates as specified complete with all extension poles for connection to the Pneumatic control systems as illustrated in drawing AI04/100/1
5	Supply and install the 40mm x 100mm rectangular tubing frame as base of pneumatic system. Supply and install the complete system of the Compressed air RAM systems c/w all rod eyes as illustrated in AI04/100/1

**CONSTRUCTION NOTES**

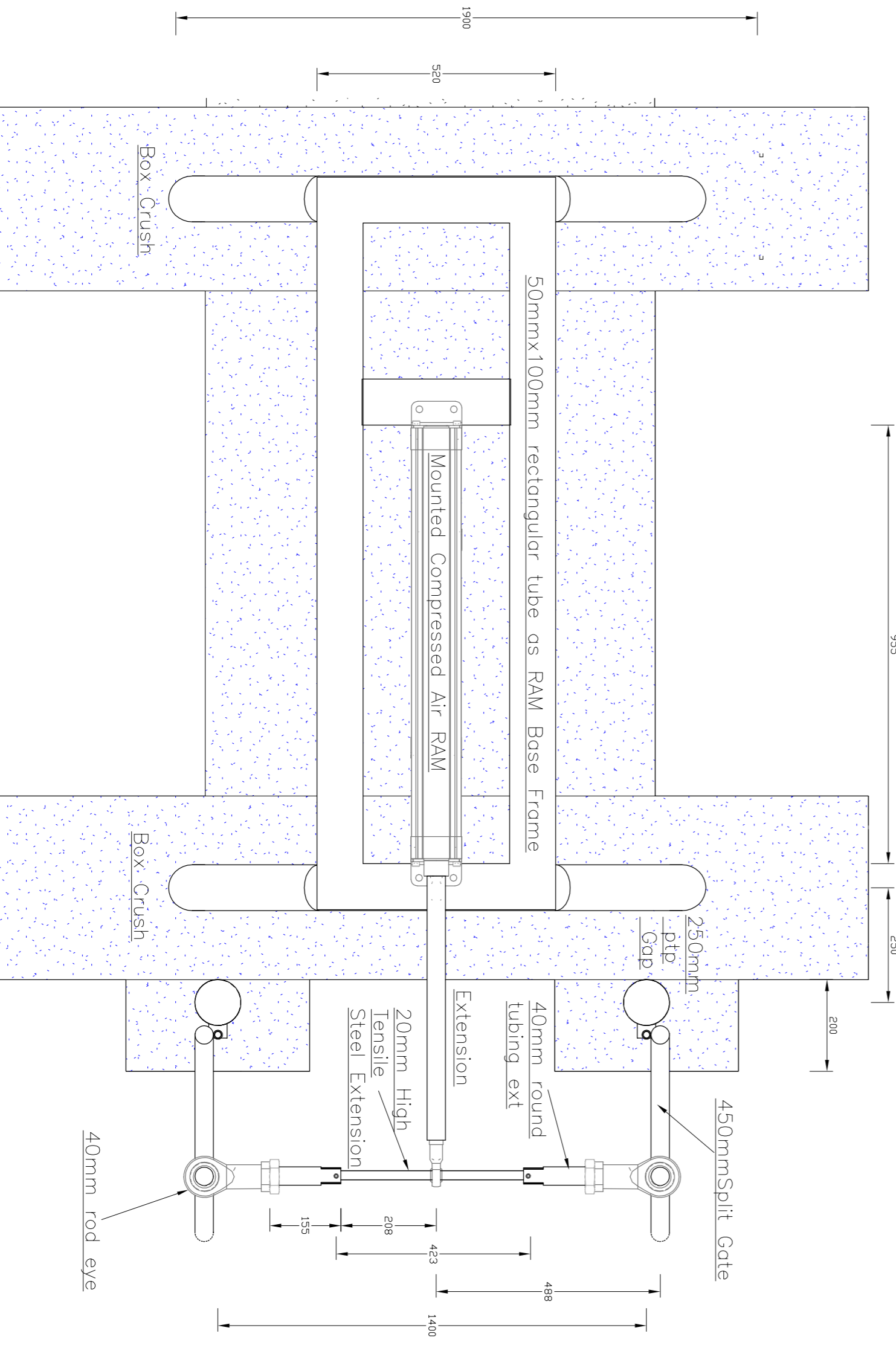

OPEN POSITION OF GATE

CLOSED POSITION OF GATE

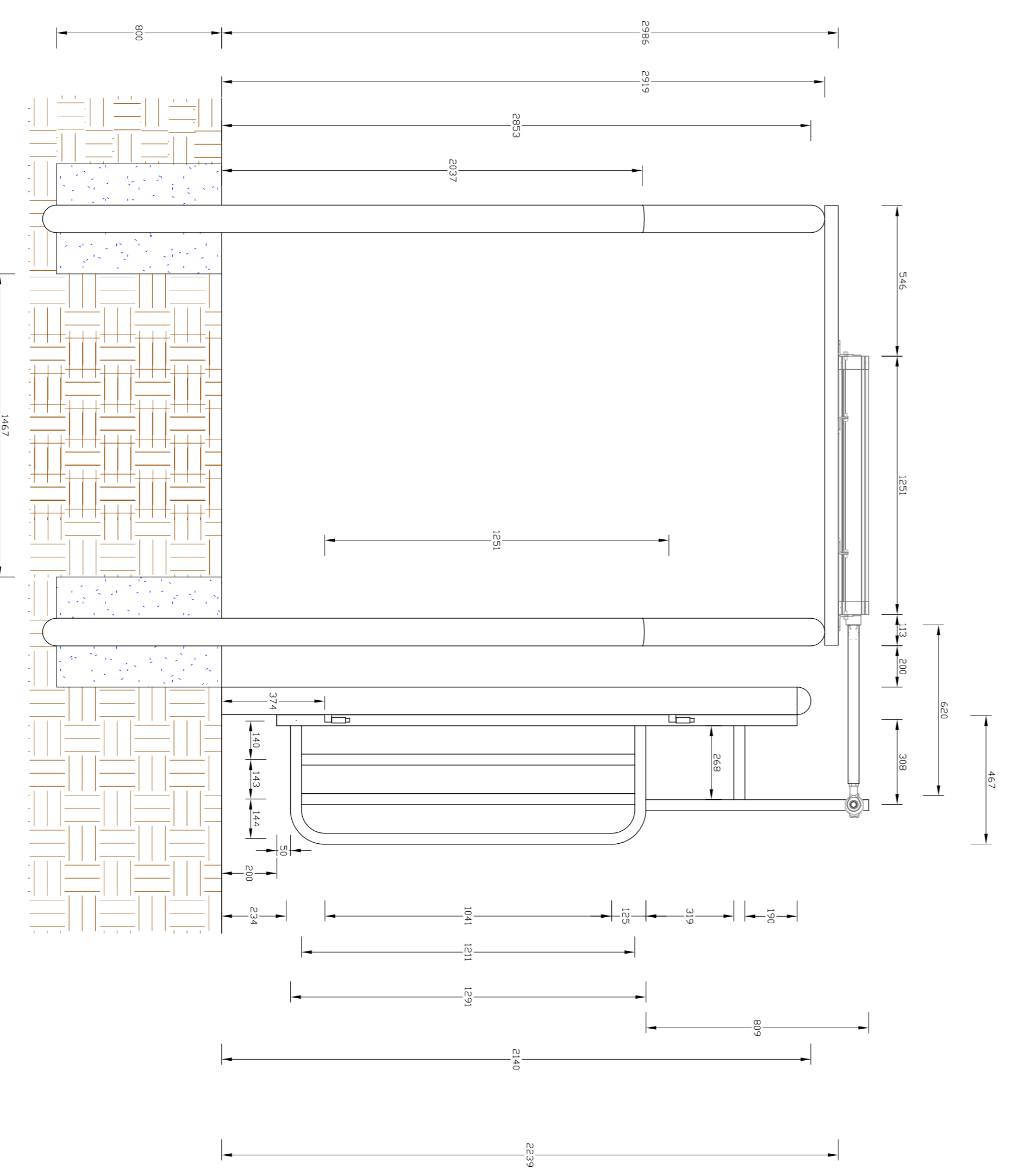

SECTION ALONG PASSAGEWAY SCALE 1:15

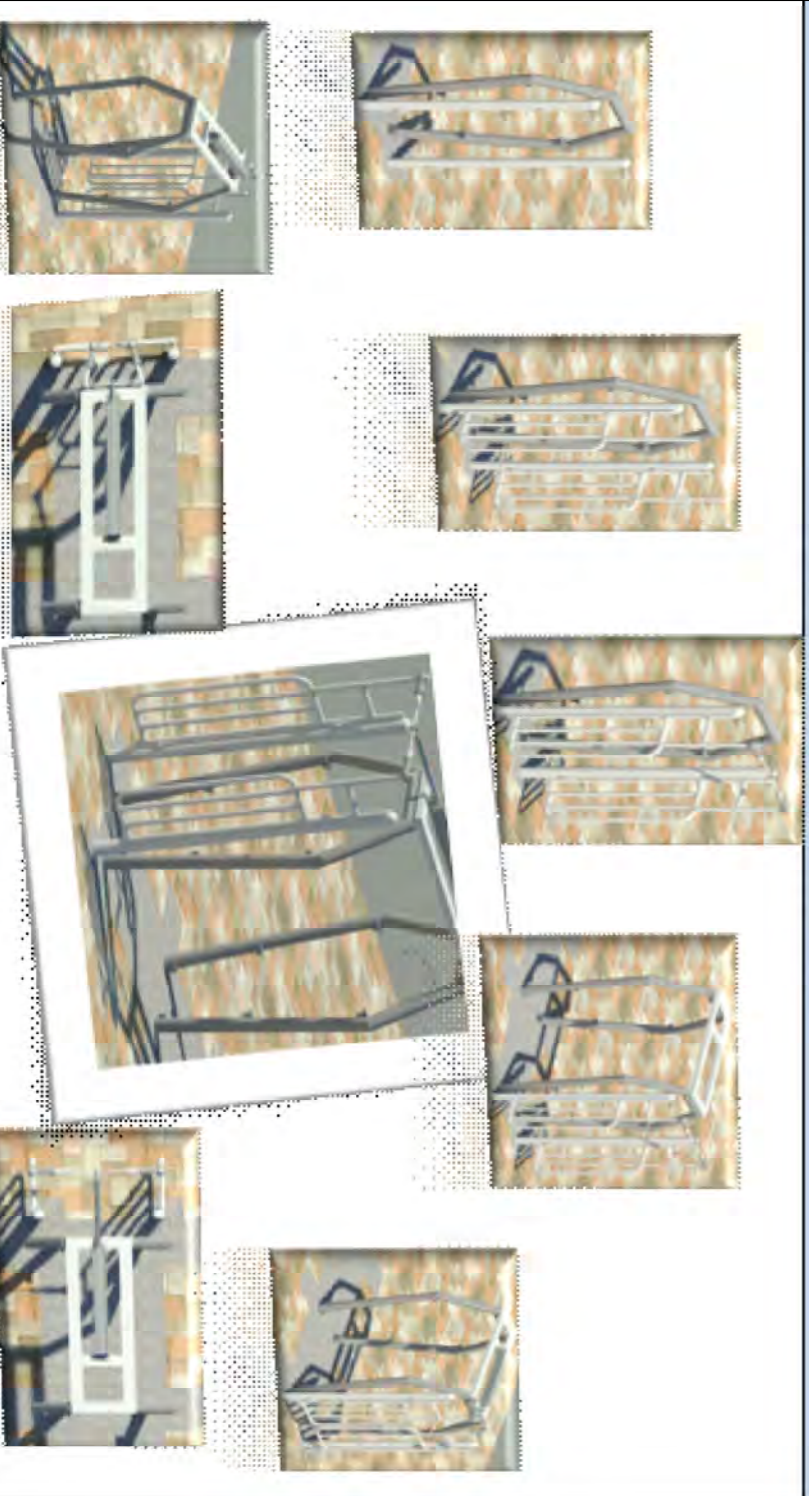

**Agricultural Research Council - Institute for Agricultural Engineering**  
Agricultural Infrastructure and Engineering Structures Division, Construction Procedure document  
P Bag X319, Silverton, Pietermaritzburg, 60127 +27(0) 12 842 4000 www.arcagric.za



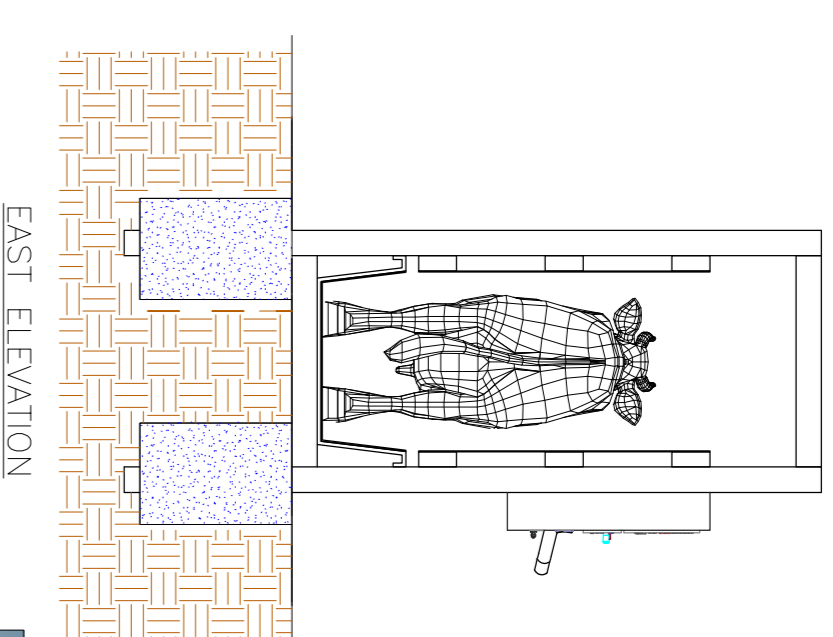
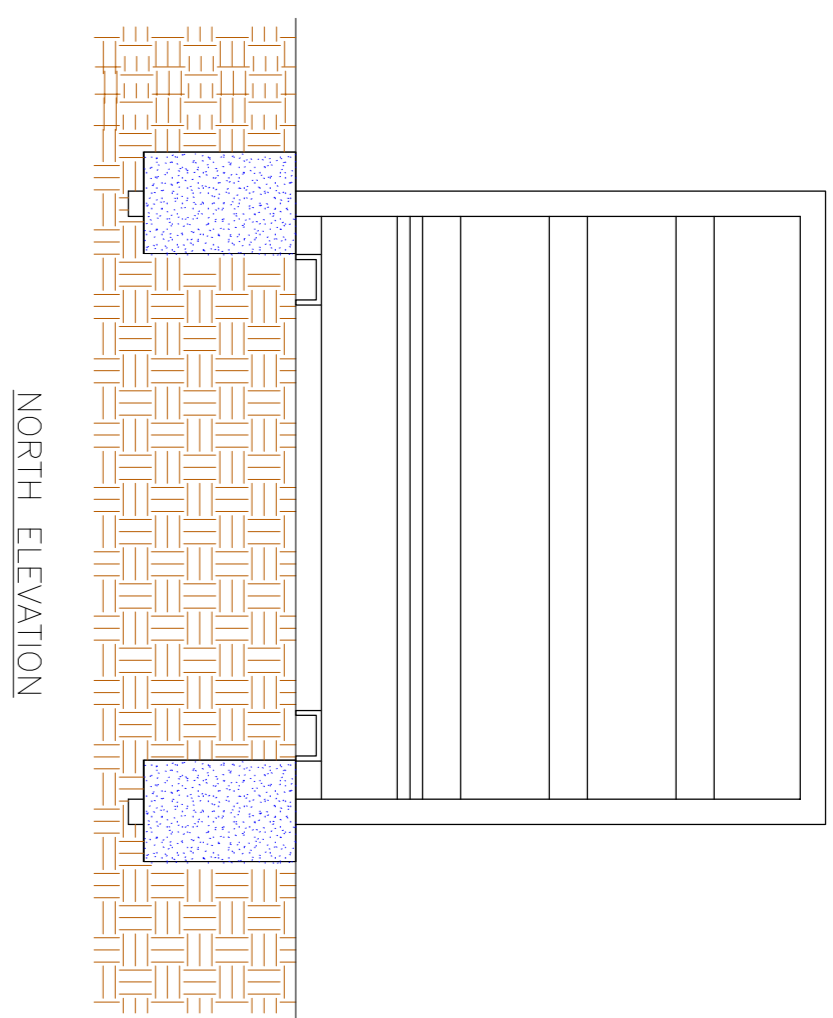
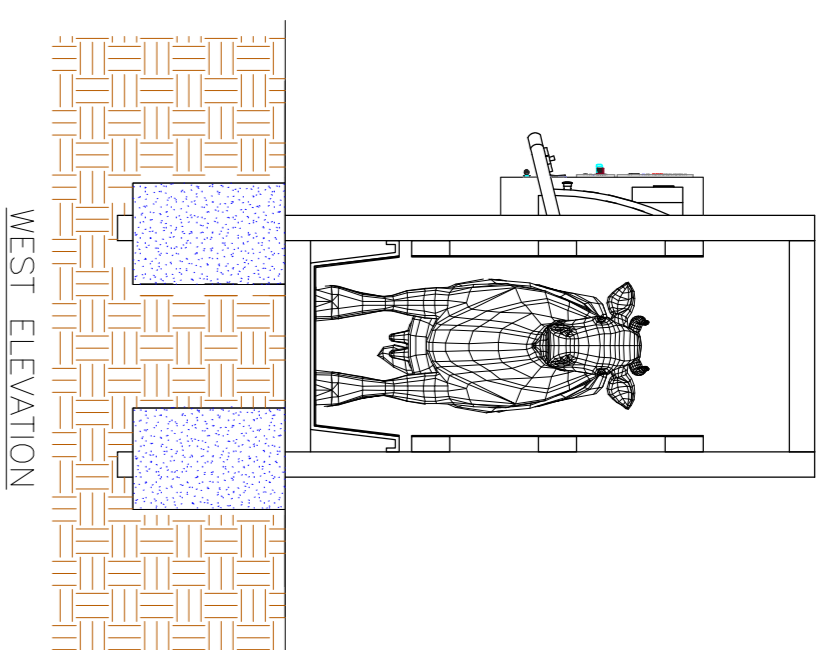

ALL ELEVATIONS ON A SCALE OF 1:30

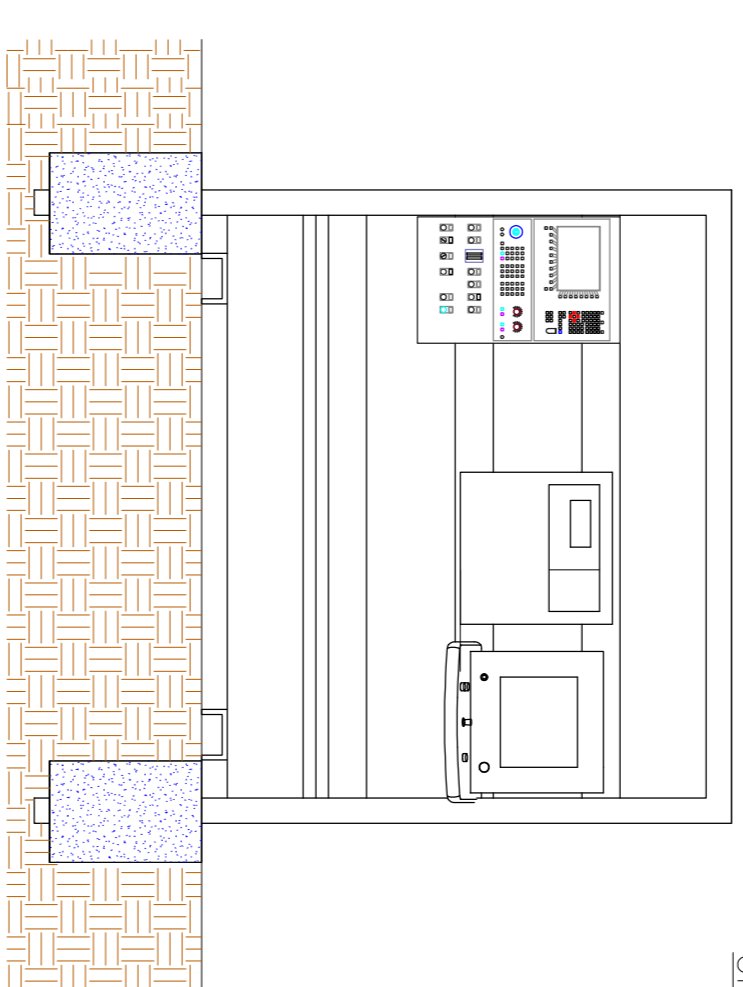

SOUTH ELEVATION

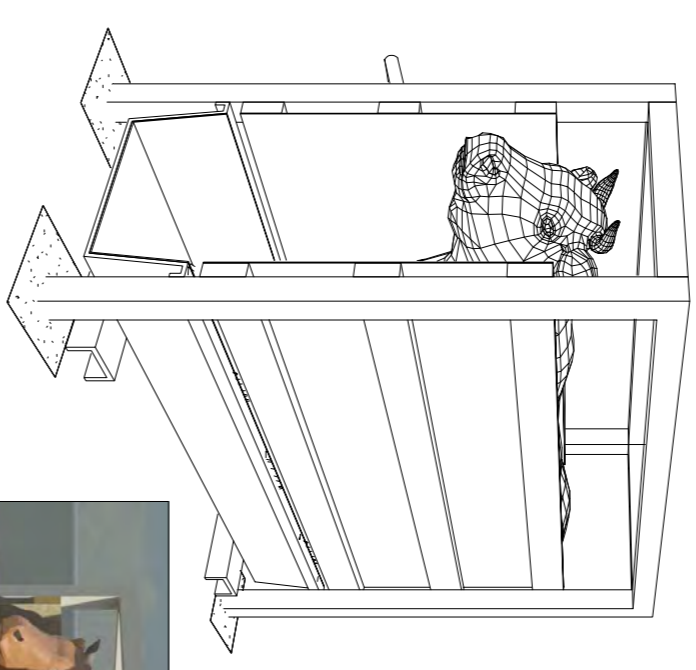

FAR SIDE CAMERA VIEW OF SYSTEM



NEAR SIDE CAMERA VIEW OF SYSTEM

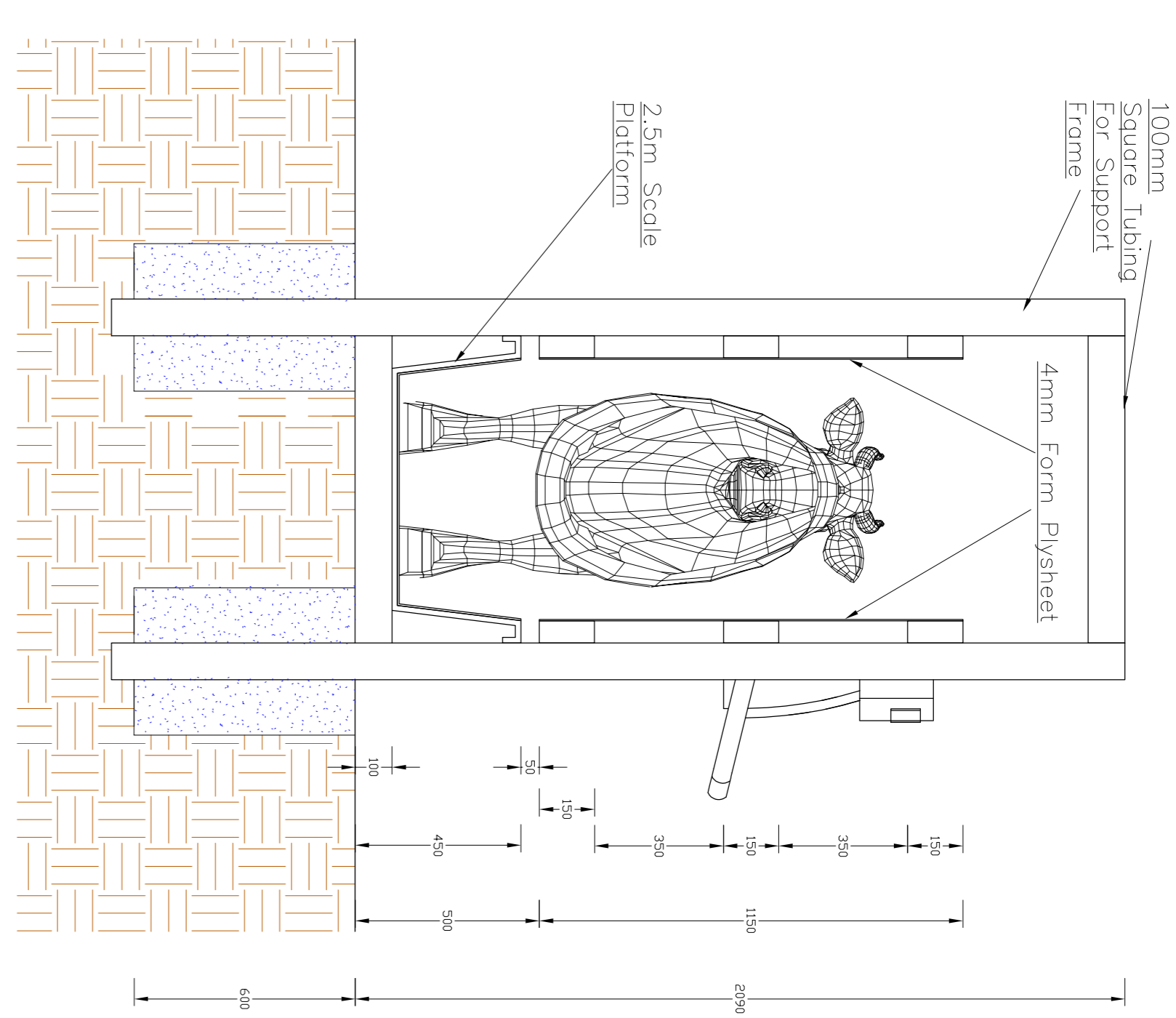

SECTION ACROSS SYSTEM SCALE 1:15



RENDERED VIEW OF ID & WEIGH BOX SYSTEM

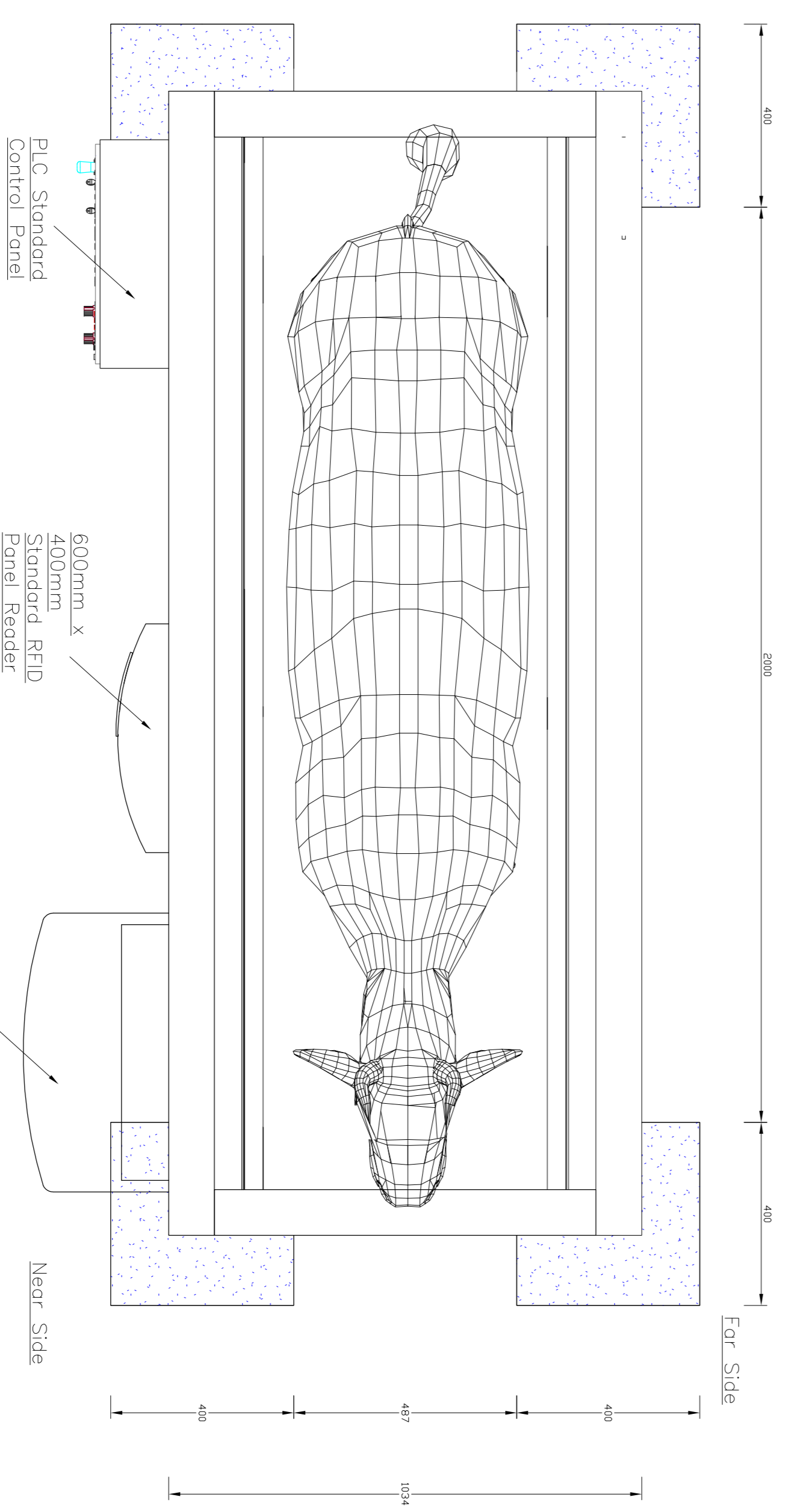

CATTLE IDENTIFICATION AND WEIGHING SYSTEM PLAN SCALE 1:10

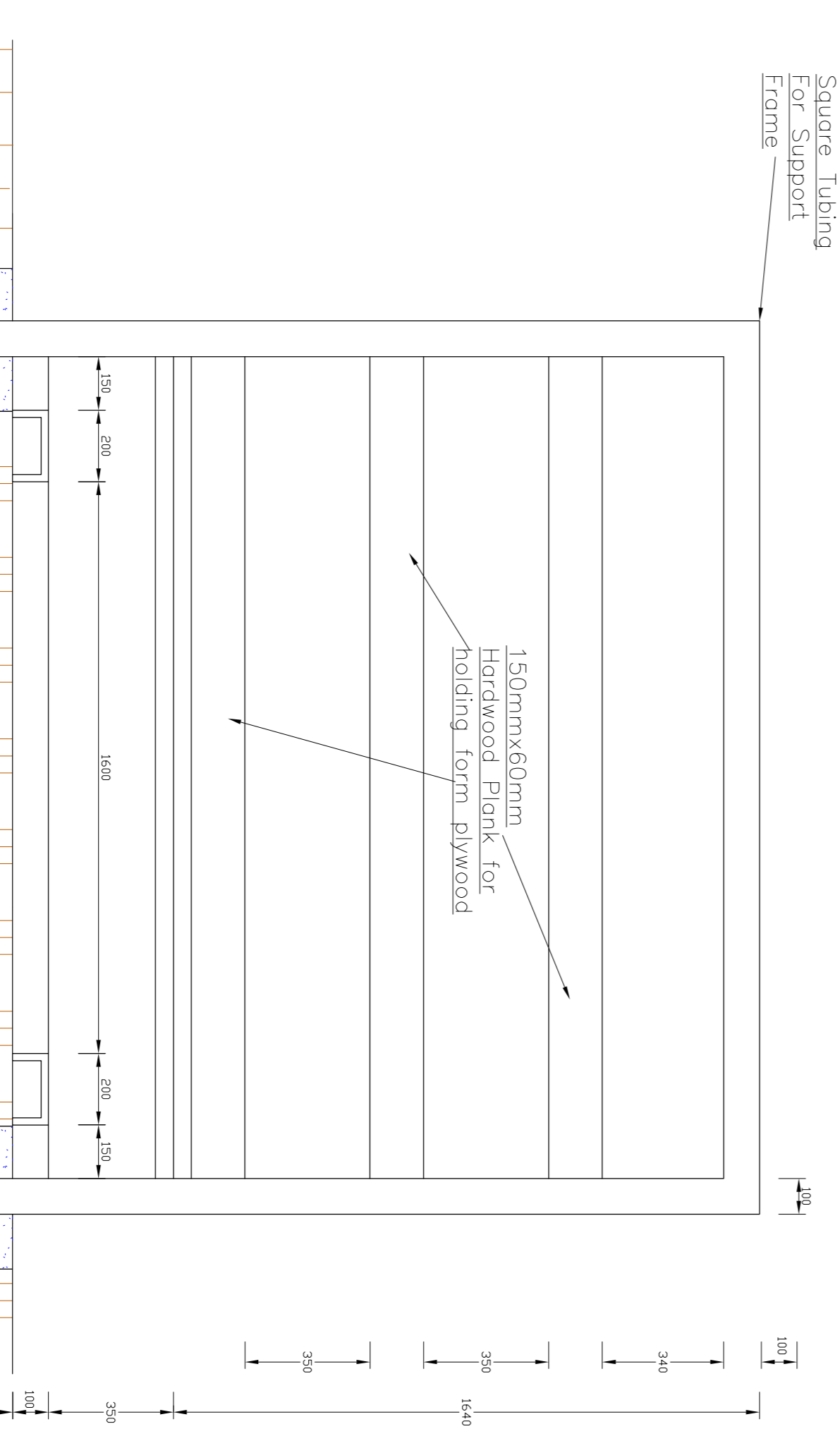

SECTION ALONG PASSAGEWAY SCALE 1:15

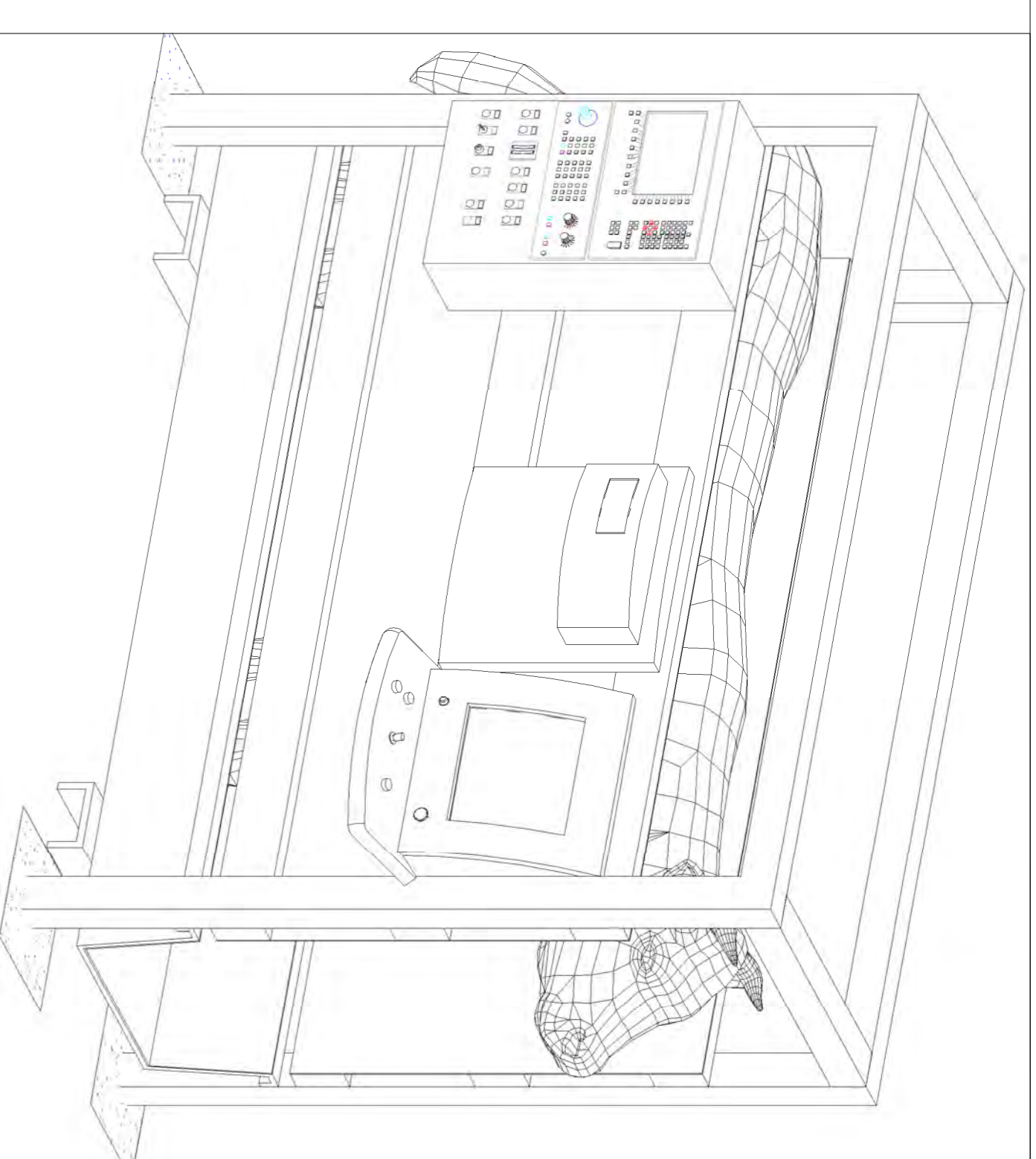

3D VIEW OF ID AND WEIGH BOX SYSTEM Scale 1:10

**IDENTIFICATION AND WEIGH SYSTEM Construction Procedures**

**COMPONENT ID**

**SUBJECT:** Construction Procedures for the Identification and Weighing System

**CONSTRUCTION NOTES**

ITEM	DETAILED DESCRIPTION
1	Clear 100mm of top soil on the ID & Weigh system construction area and excavate for the 2 Structural Support assembly 400mm x 400mm x 600mm and compact until no further collapse.
2	Supply and install the two 100mm Square tubing support frames in the excavated holes. Supply and install the six 150mmx60mm hardwood pine for plyform mounting.
3	Supply and install the two side 1500mmx2500mm form 4mm ply/sheeting on wall sides as illustrated in drawing A104/100/4 inclusive of all suitable fasteners.
4	Supply and install two 1000mm load cells complete with all scale platforms and reading unit as specified and illustrated. Supply and install a suitable 600mmx400mm RFID panel reader for cattle RFID passive tags reading as illustrated in A104/100/4.
5	Supply and install a pre Engineered PLC Automation Control Box and all connections for control of air rams for the complete system as illustrated in A104/100/4

**PICTORIAL PROCEDURES:**



**ARC • LVA**  
Agricultural Infrastructure and Engineering Services Division, Construction Procedure document  
P Bg 3519, Silverton, Pretoria 0127 +27(0) 12 842 4000 www.arc.agric.za

**INSTITUTE FOR AGRICULTURAL ENGINEERING**  
LANDBOUWONGENSIERSKAP

**ARC • LVA**  
INSTITUUT VIR LANDBOU-INGENIEURSWESIE

**RFID CATTLE HANDLING SYSTEM IDENTIFICATION & WEIGHING SYSTEM**

SCALE: PLAN 1:10  
DATE: 20 OCT 2010  
REV. NR.: 09AMW NO.

DESIGNER: P. J. BRITZ  
PROJ. LEADER: P. J. BRITZ  
APP. NO.: 100  
PAGE NO.: 4

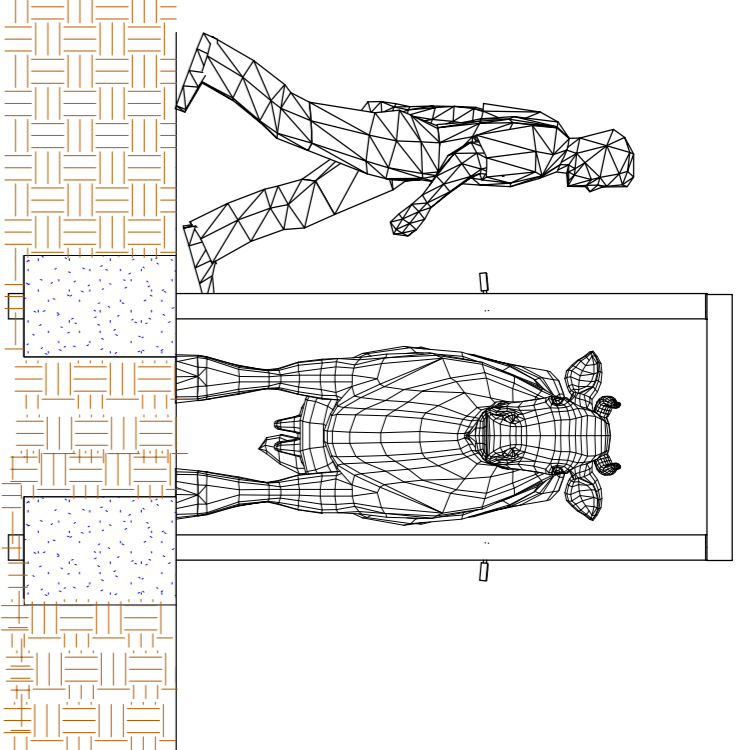

WEST ELEVATION

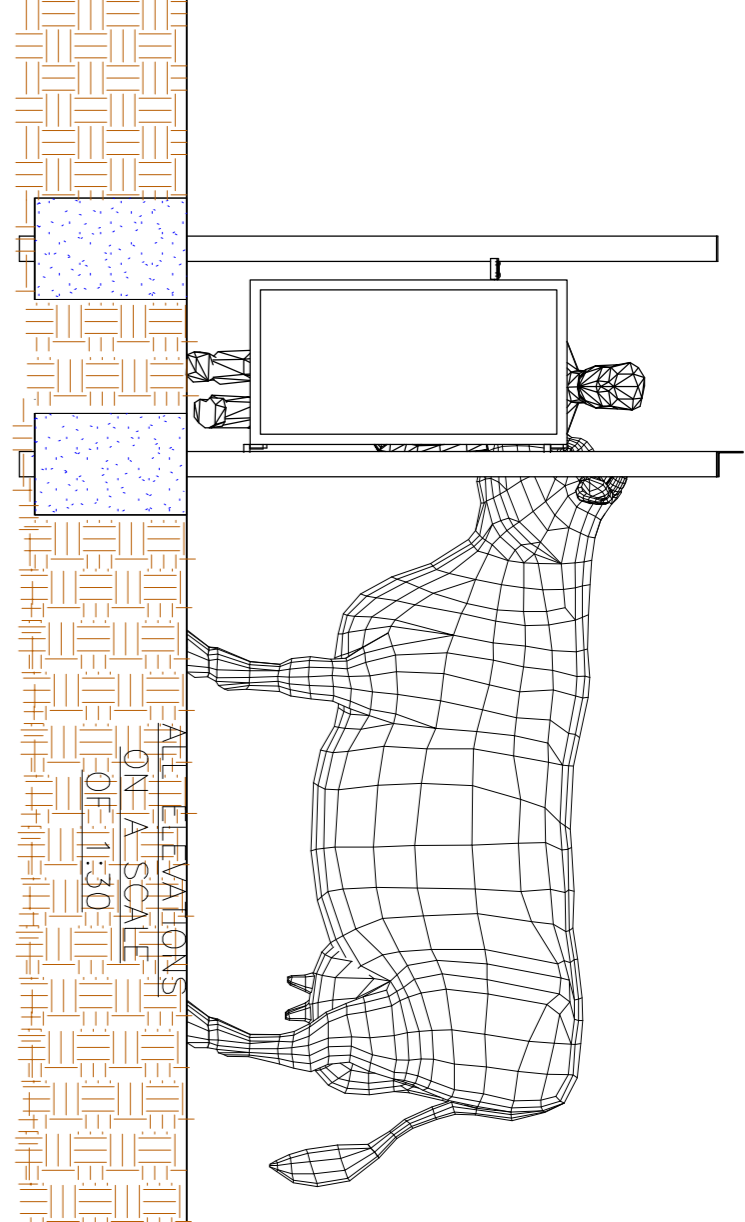

NORTH ELEVATION

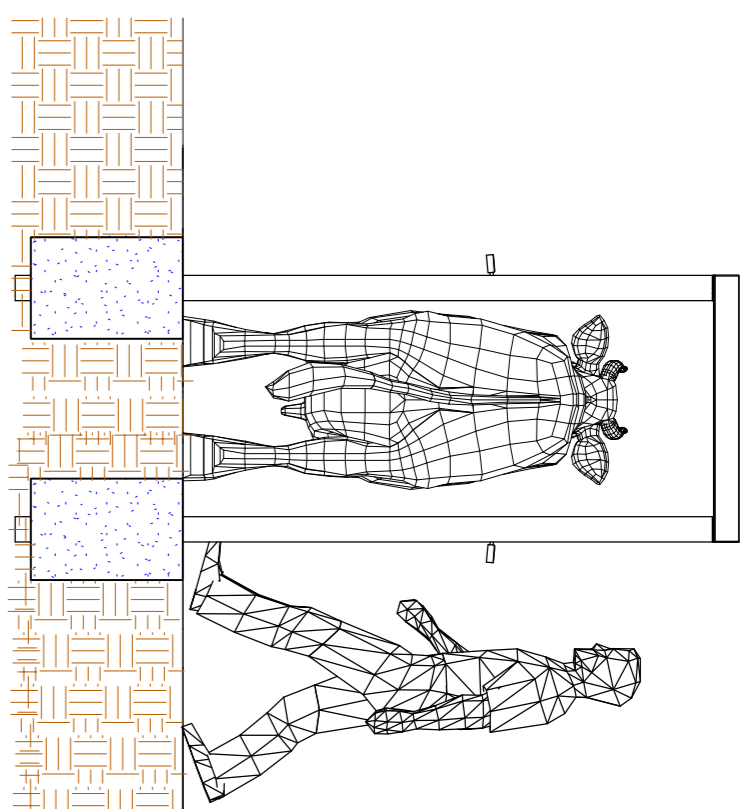

EAST ELEVATION

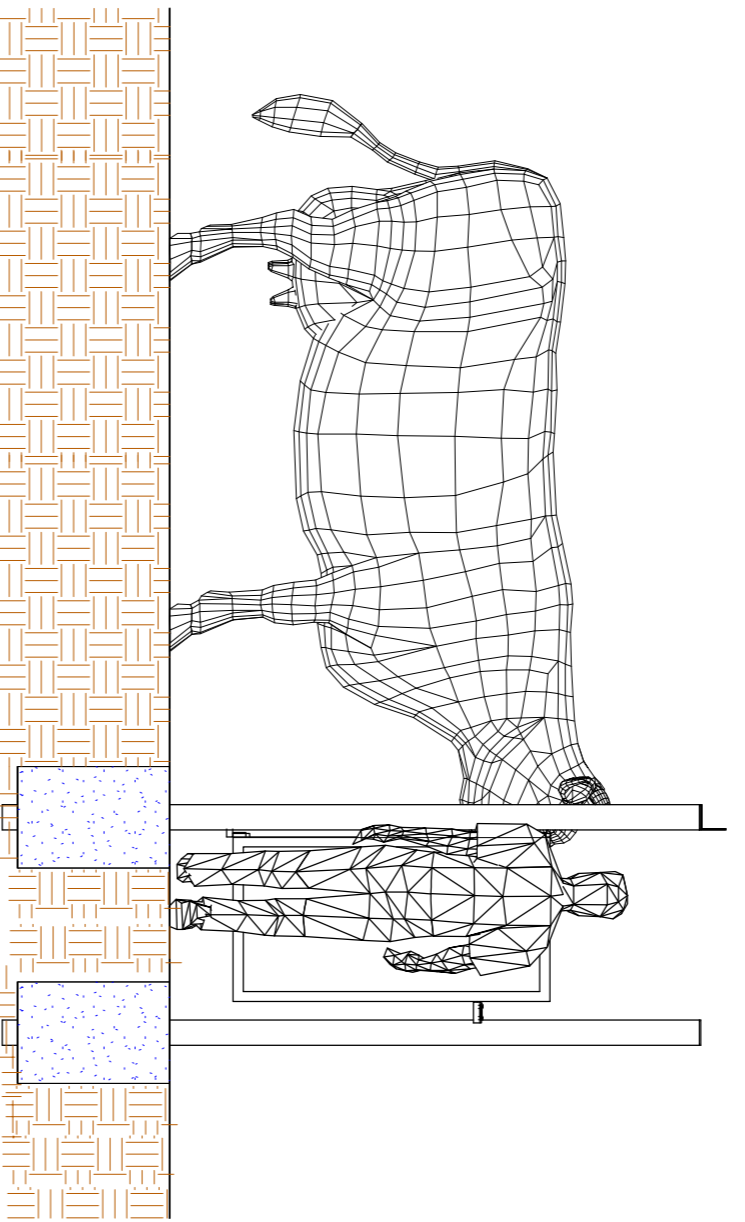

SOUTH ELEVATION

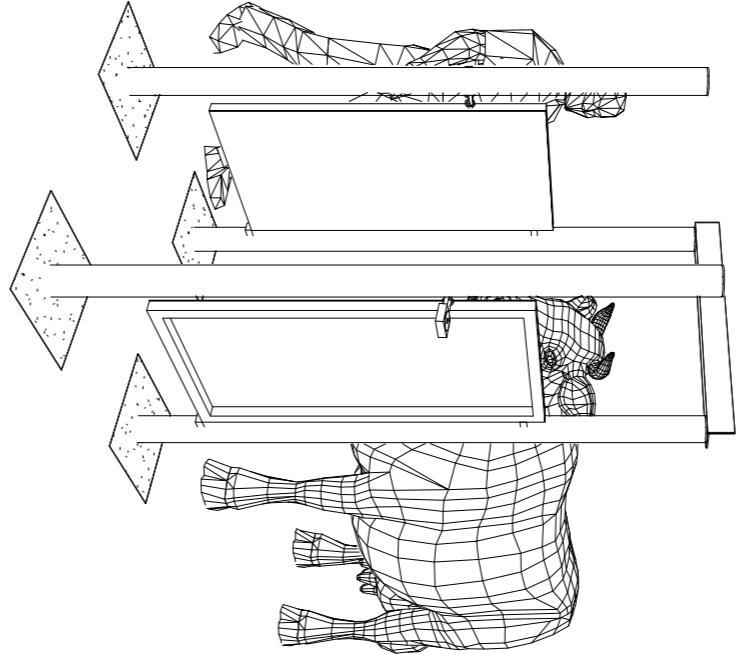

FARSIDE CAMERA VIEW OF GATE SYSTEM

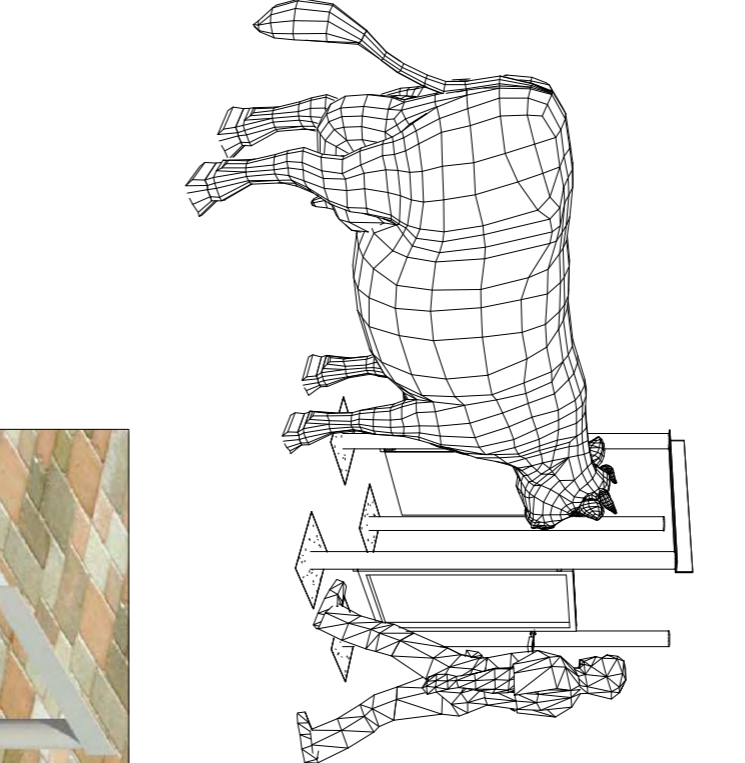

NEARSIDE CAMERA VIEW OF GATE SYSTEM

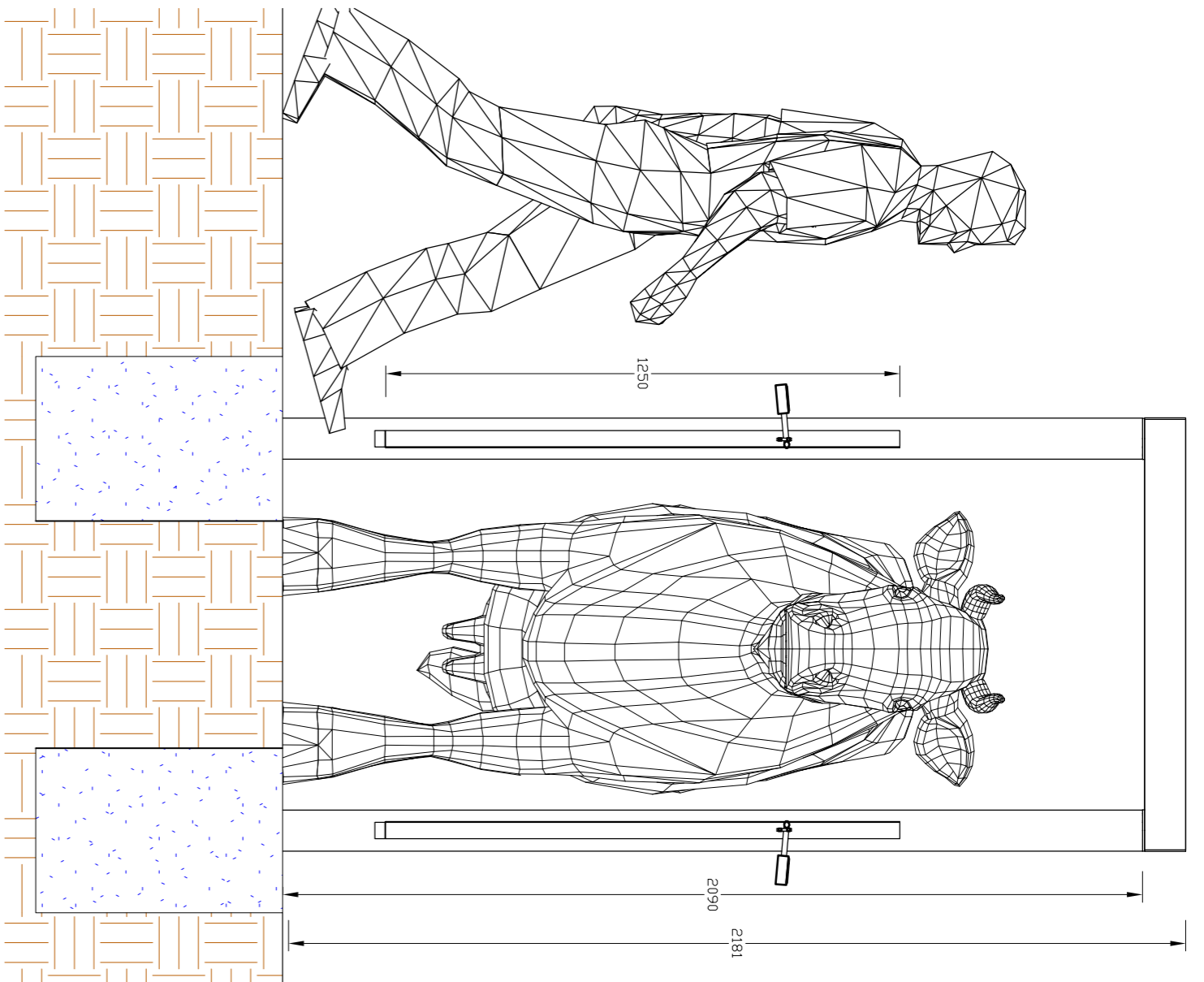

SECTION ACROSS GATES SCALE 1:15

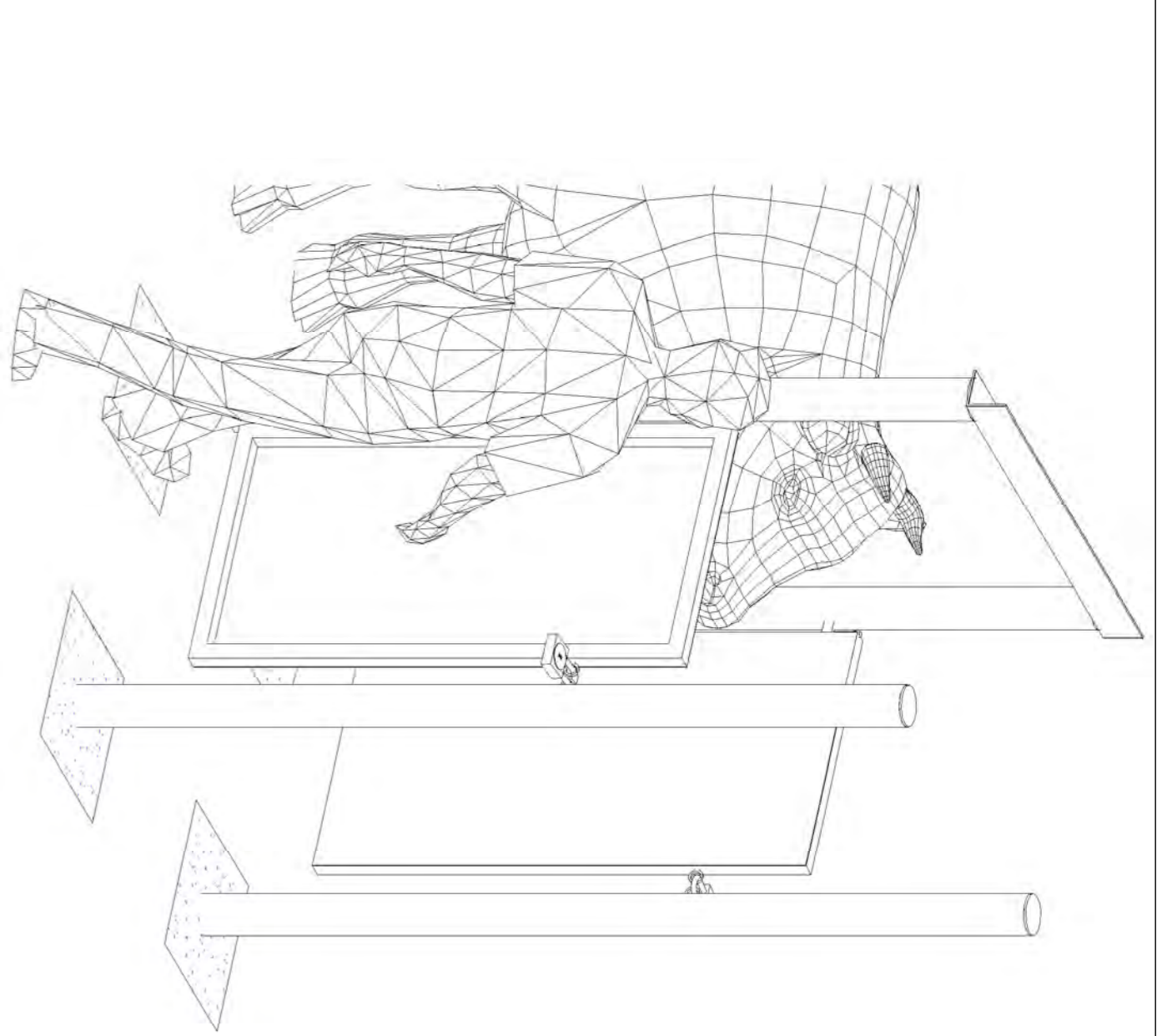

3D VIEW OF HANDLER ACCESS GATES Scale 1:10

**HANDLER ACCESS GATES**  
Construction Procedures

COMPONENT F

**SUBJECT:** Construction Procedures for the Handler Access Gates system

- COMPONENTS:**
1. Handler Access Gates
  2. Planted Posts
  3. Reinforcement angle
  4. Gate Locking

**PURPOSE:** Gates allows man passage between the near and far side of system

**PROJECT NUMBER:** AI04/100

**DESIGN BY:** Tendai Justin Mutenje  
Agricultural Engineer

ITEM	DETAILED DESCRIPTION
1	Clear 100mm of top soil on the construction area and excavate for the 4 planted posts 400mm x 400mm x 600mm deep and compact until no further collapse.
2	Supply and install the 4 posts in the excavated holes. (Details of the handler access gates assembly are specified in drawing no AI04/100/6.)
3	Cast concrete around the planted posts and temper to ground level as specified and illustrated in drawing no AI04/100/6. Cure concrete by wetting and keeping damp
4	Supply and place angle iron pieces for planted poles supports complete with all gate hinges mechanisms as illustrated in drawing AI04/100/6
5	Supply and install the two(2) Handler access gates complete with gate locking systems for safety reasons as illustrated in AI04/100/6

**PICTORIAL PROCEDURES:**

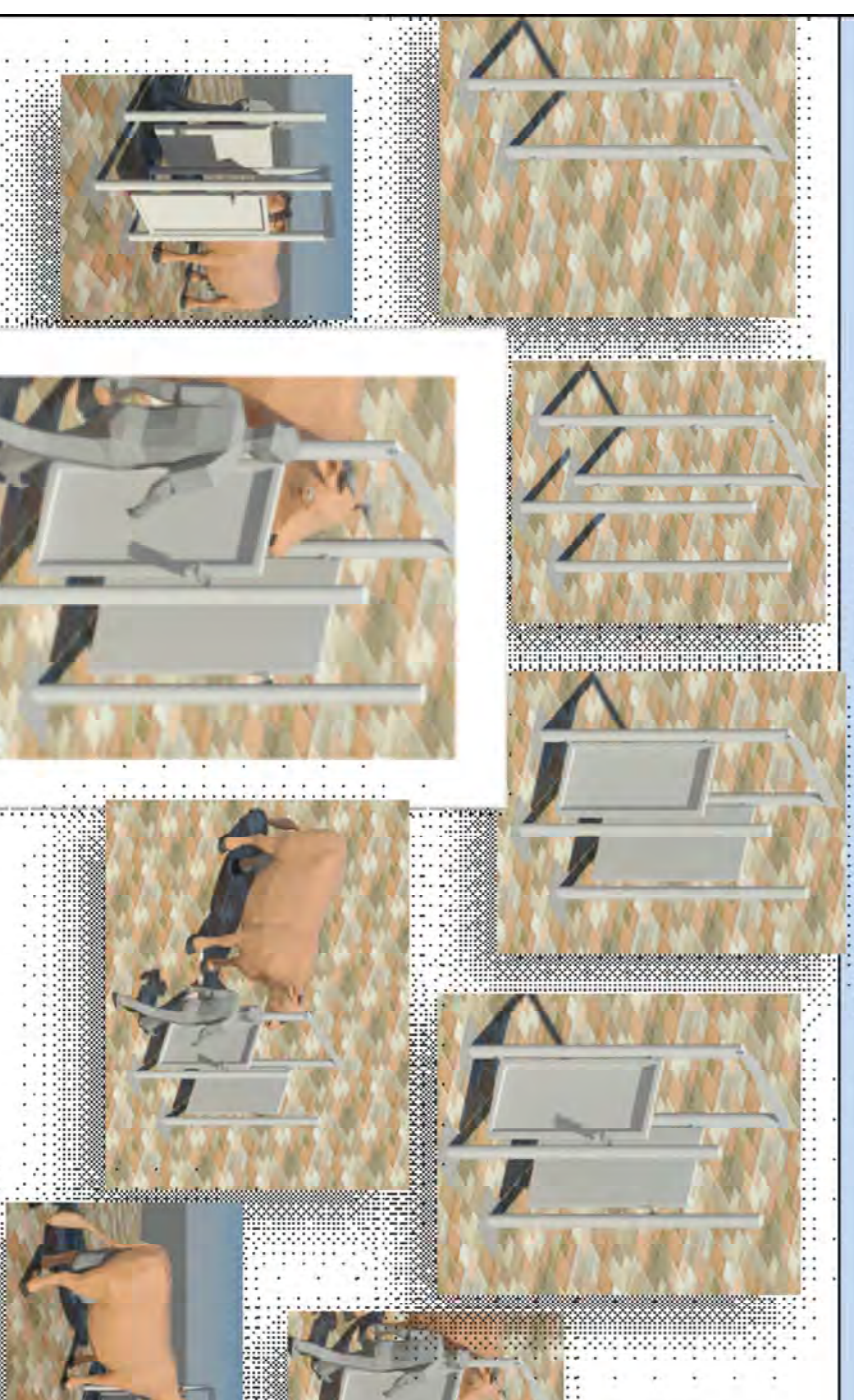

**Agricultural Research Council - Institute for Agricultural Engineering.**  
Agricultural Infrastructure and Engineering Structures Division, Construction Procedure document  
P Bag 3519, Silverton, Pretoria, 0127 +27(0) 12 842 4900 www.arc.ac.za

**INSTITUTE FOR AGRICULTURAL ENGINEERING**  
AGRICULTURAL RESEARCH COUNCIL

**ARC • IAE**

**INSTITUT VIR LANDBOU - INGENIEURSWESIE**  
LANDBOUWONNINGSKAP

**RFID CATTLE HANDLING SYSTEM**  
**HANDLER ACCESS GATES SYSTEM**

SCALE: 1:90A 1:10  
DATE: 30 OCT 2010  
TRC NR: 09AMM NO.

DESIGNER: T. J. MUTENJE  
DRAWING: T. J. MUTENJE  
PROJ. LEADER: J. MUTEJE  
MANAGER: J. BRITZ

PROJECT NO.: 100  
PAGE NO.: 04/4/100  
6

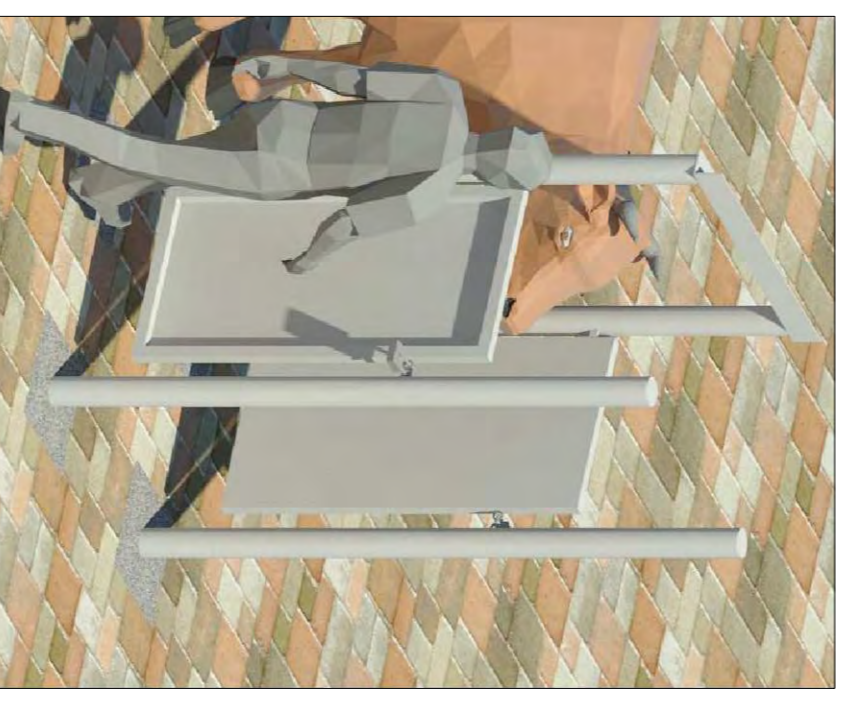
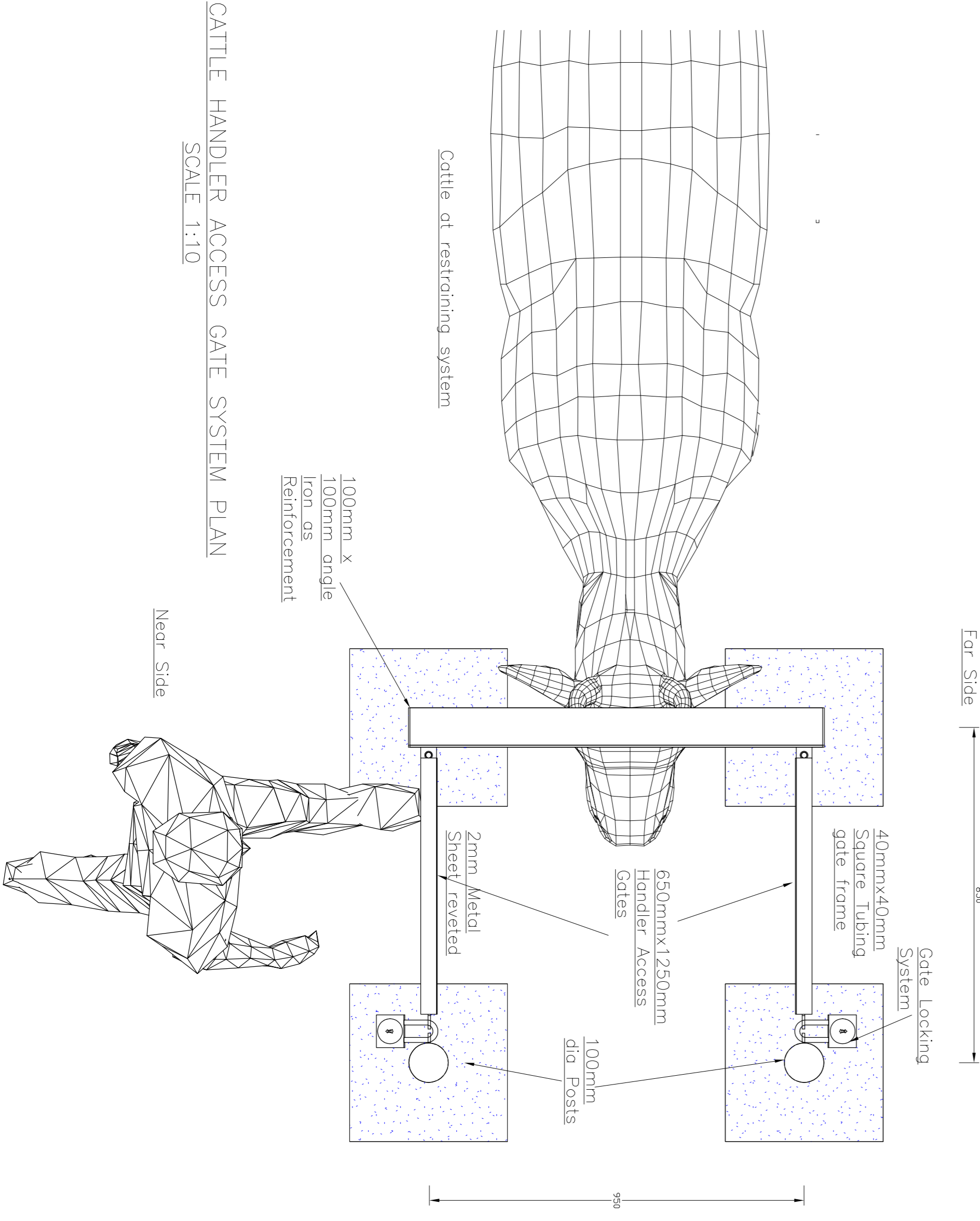

RENDERED VIEW OF SPLIT GATES SYSTEM

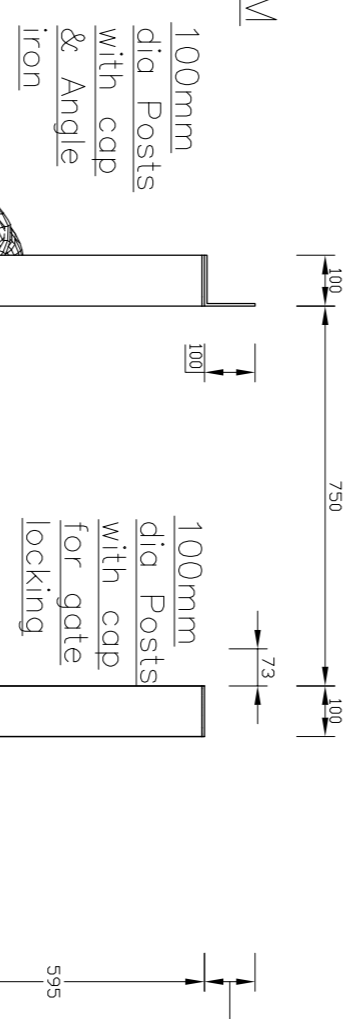

SECTION ALONG PASSAGEWAY SCALE 1:15

CATTLE HANDLER ACCESS GATE SYSTEM PLAN SCALE 1:10

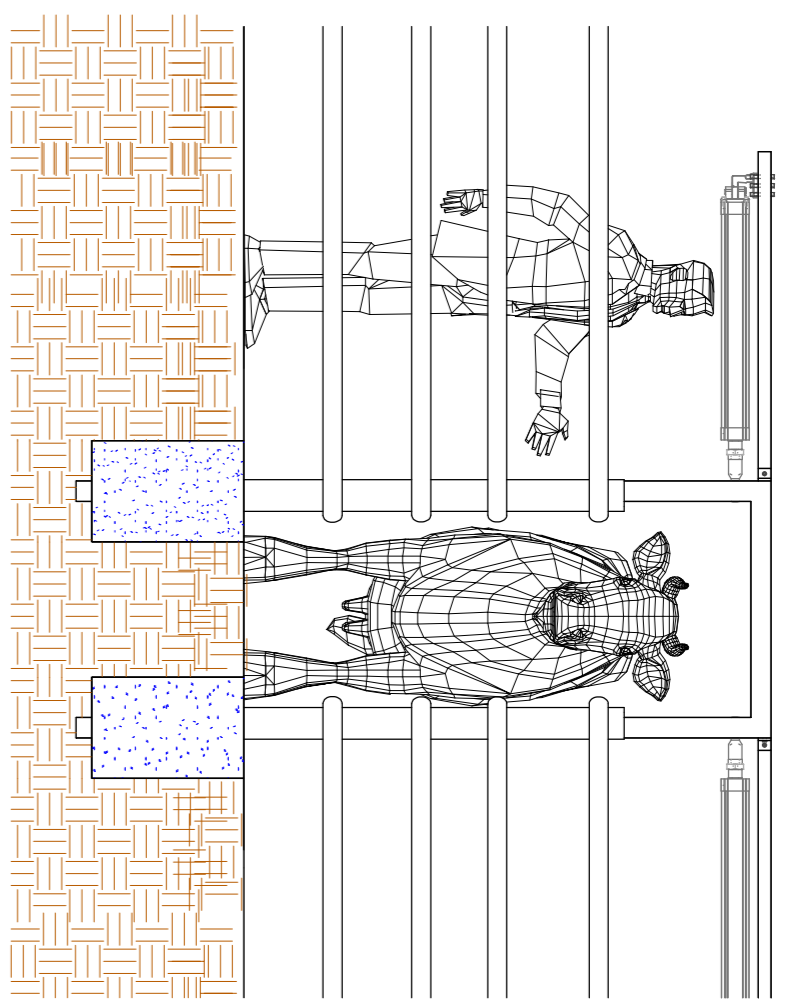

WEST ELEVATION

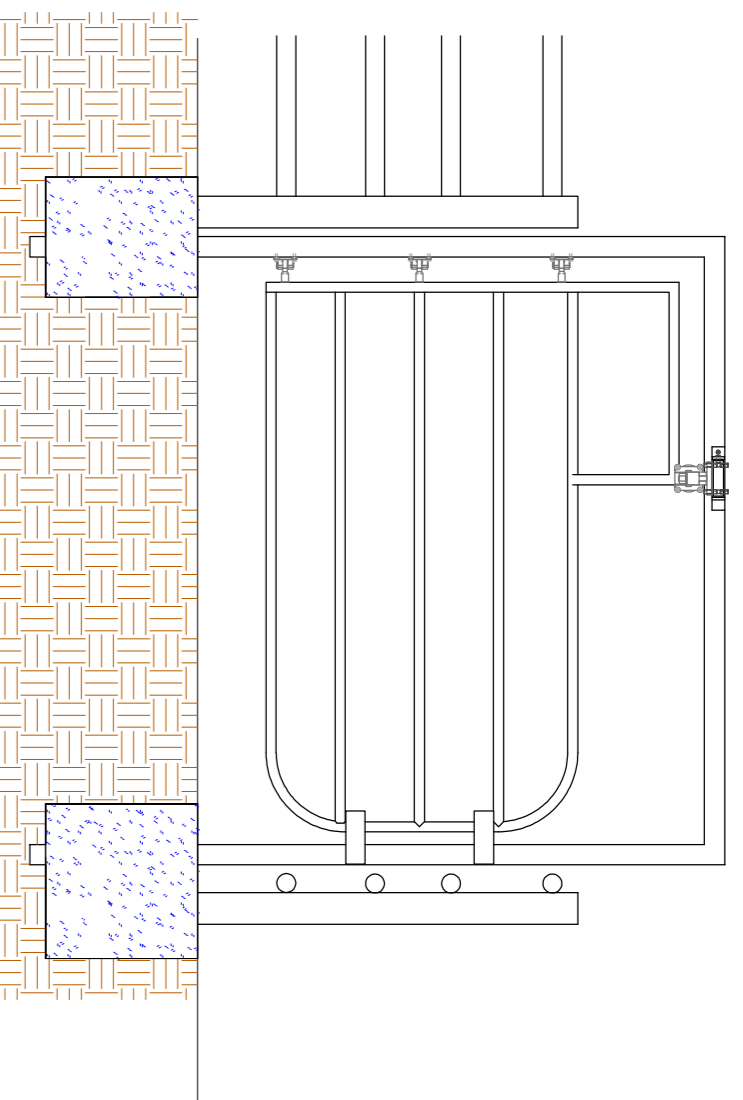

NORTH ELEVATION

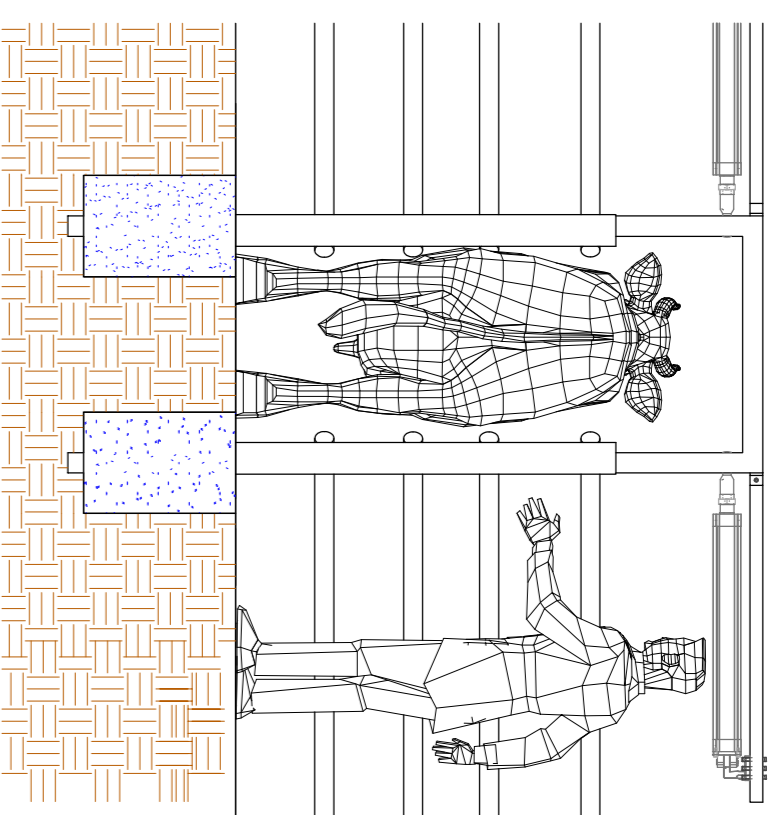

EAST ELEVATION

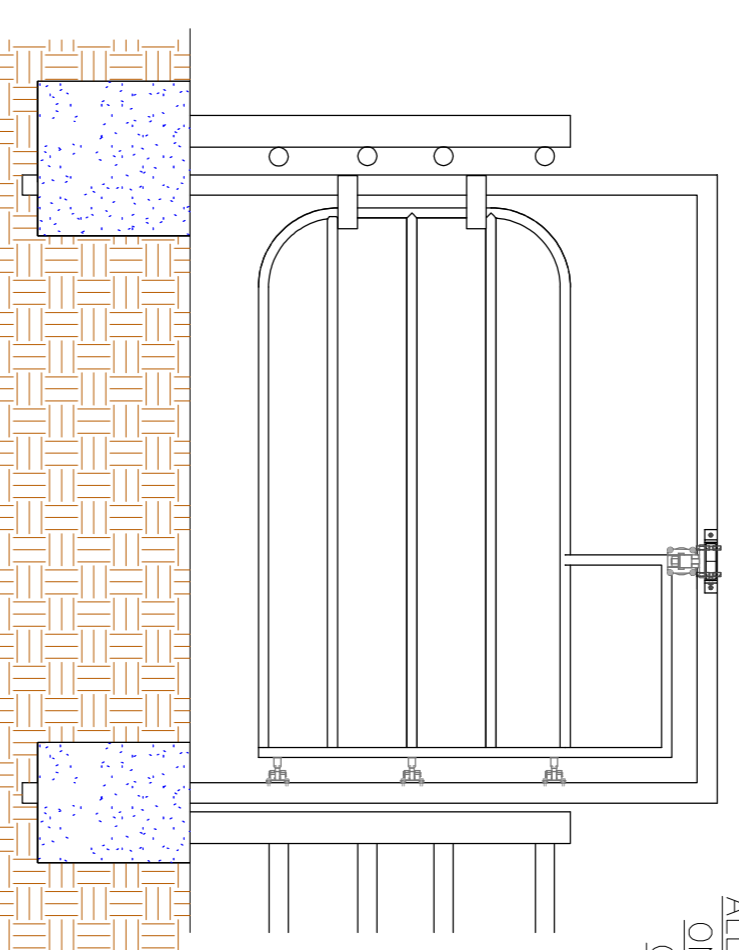

SOUTH ELEVATION

ALL ELEVATIONS ON A SCALE OF 1:30

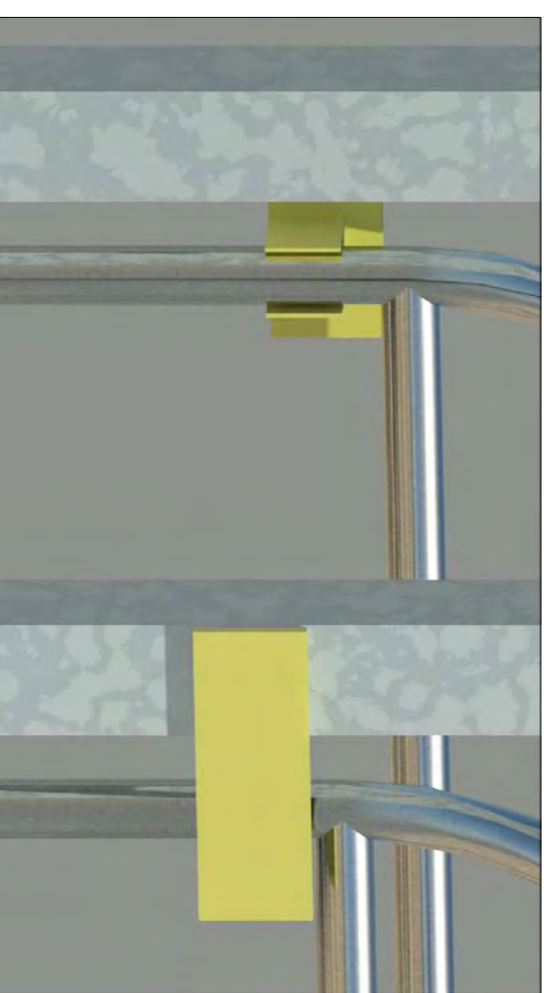

GATES AND STOPPERS

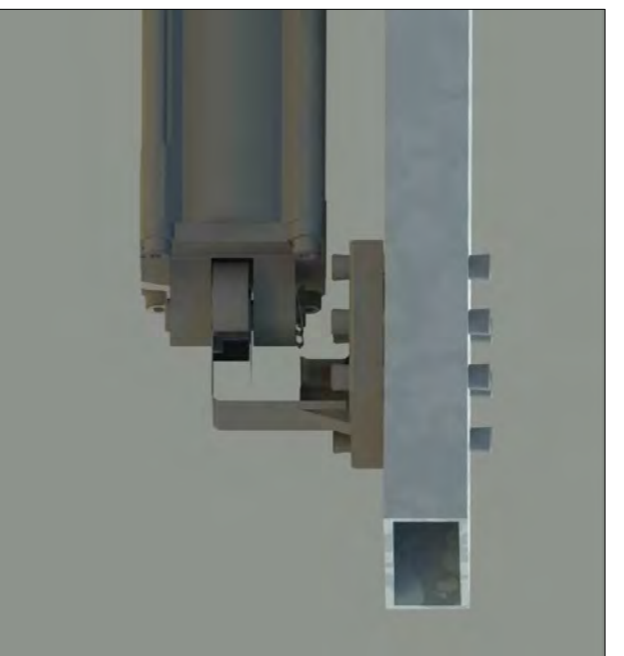

RAM SWIVEL MOUNTING

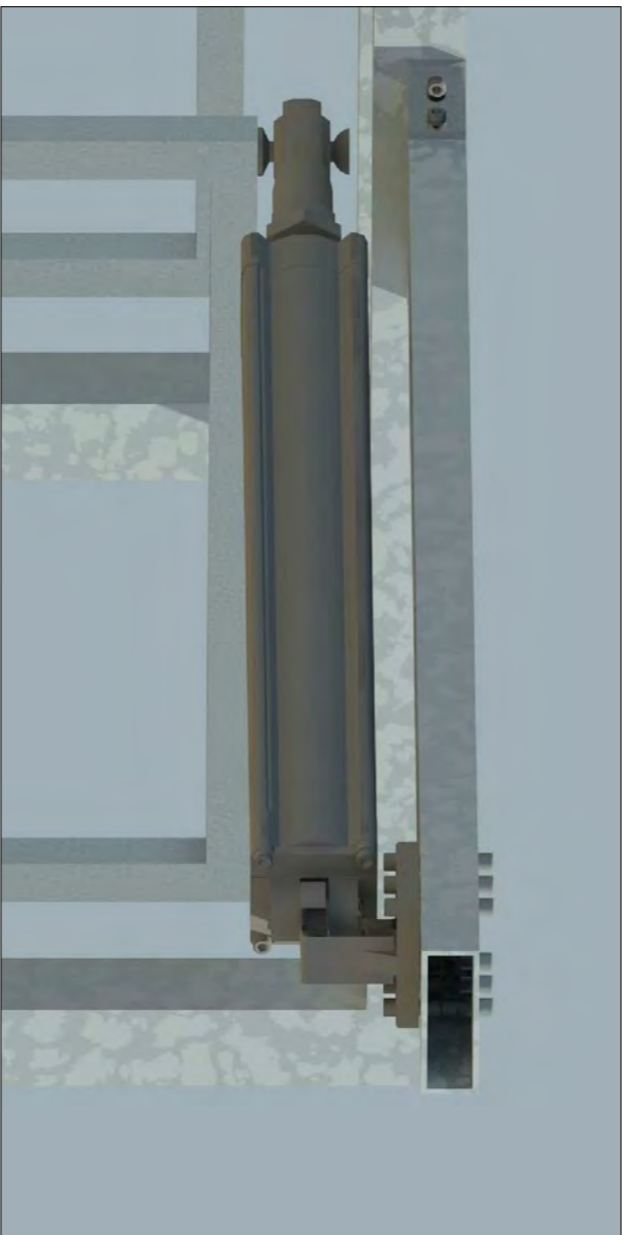

CAMERA VIEW ALONG ALLEYWAY FROM HOLDING PENS



RENDERED VIEW OF SORTING GATES SYSTEM

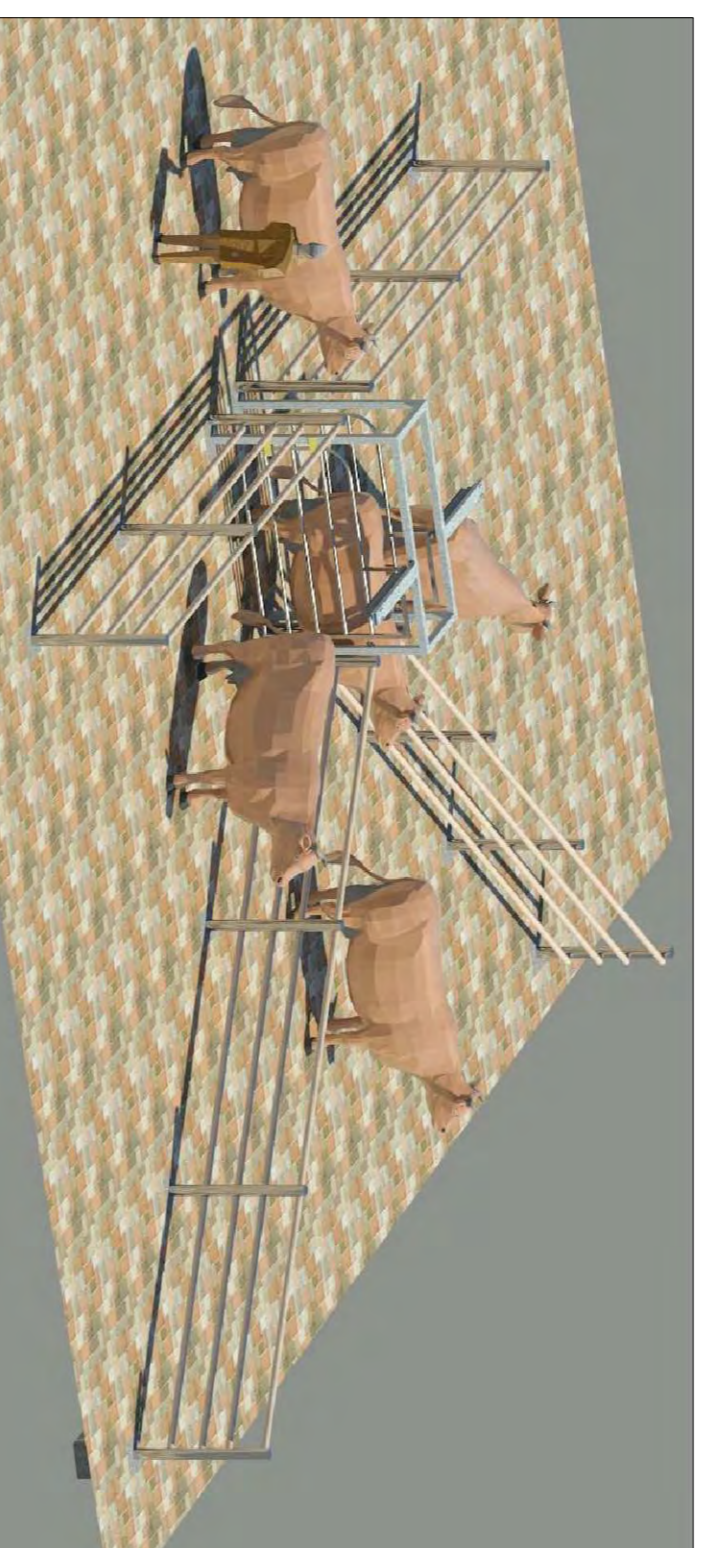

CAMERA VIEW ALONG ALLEYWAY FROM CRUSH SIDE



GATES HINGES

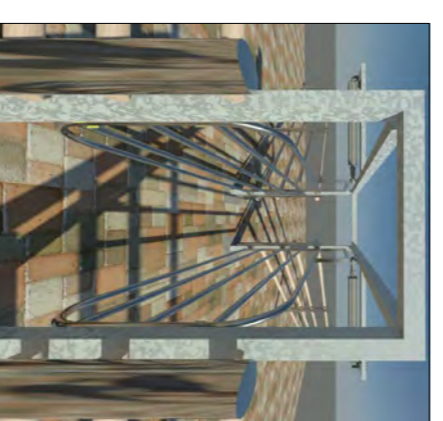

CAMERA VIEW ALONG ALLEYWAY FROM CRUSH SIDE

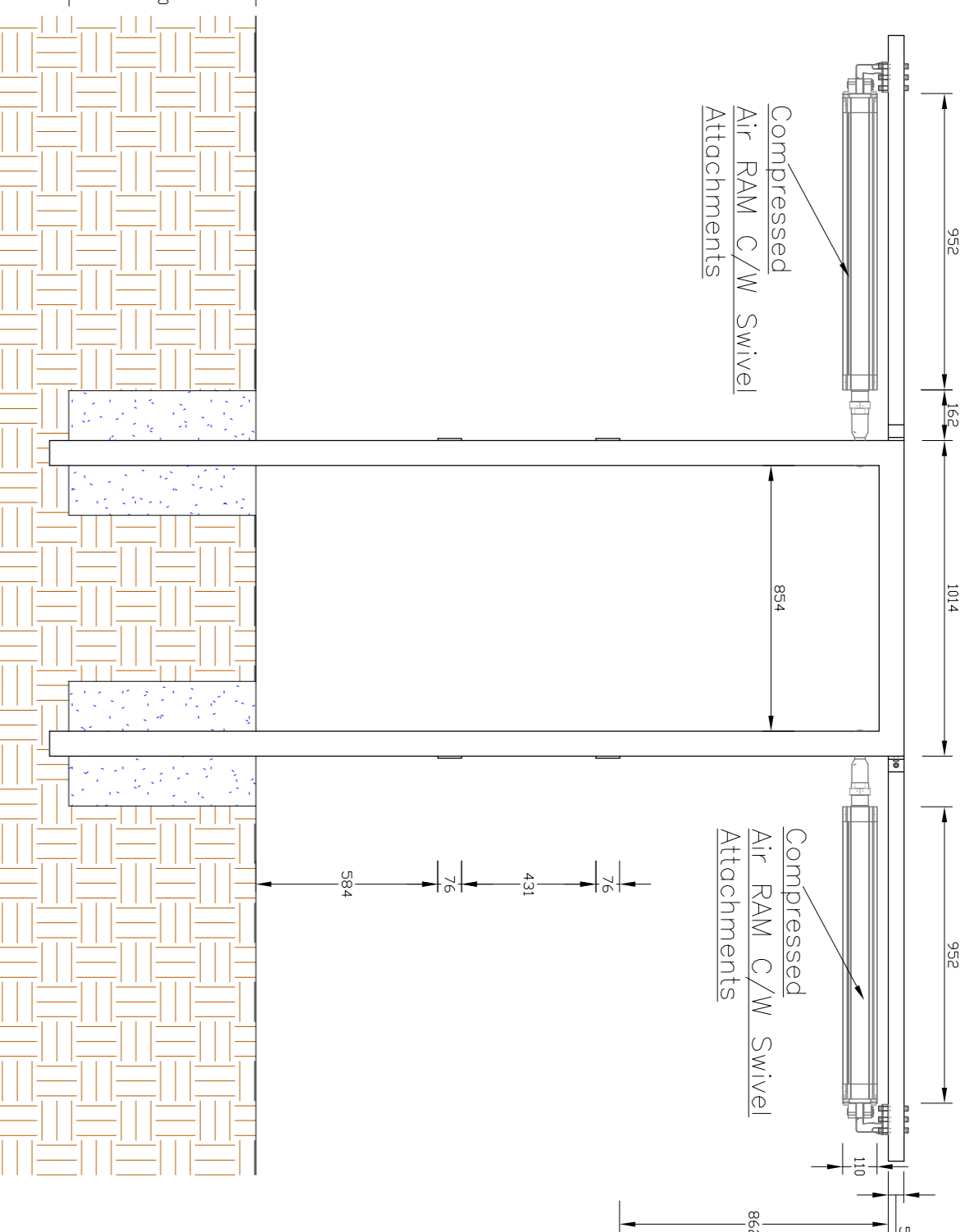

SECTION ACROSS GATES SCALE 1:20

3D VIEW OF SORTING GATES SYSTEM Scale 1:40

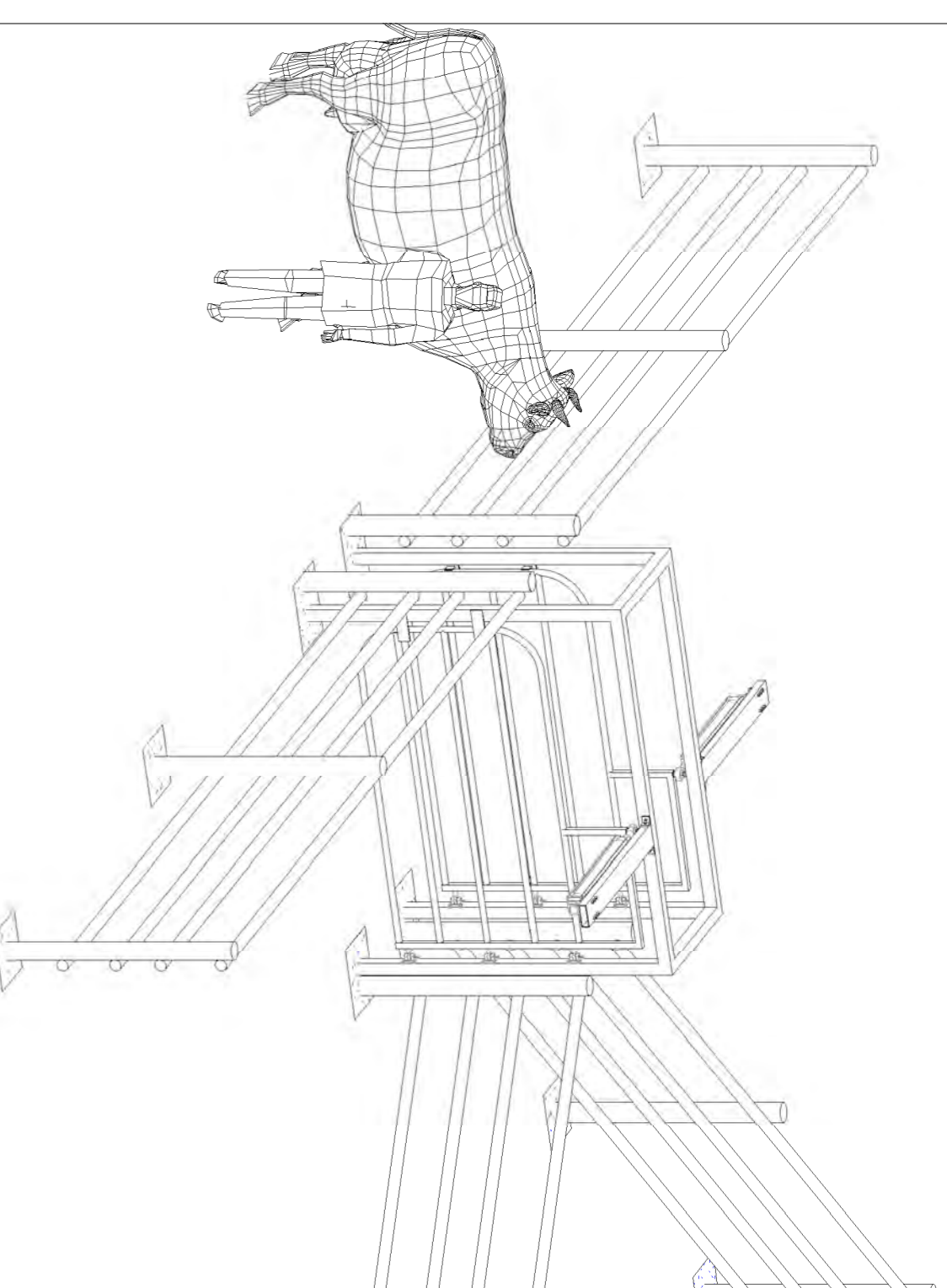

CATTLE SORTING SYSTEM Construction Procedures COMPONENT G

CONSTRUCTION NOTES

ITEM	DETAILED DESCRIPTION
1	Clear 100mm of top soil on the automater/cattle sorting system construction area and excavate 4 holes for the support frames assembly. 400mm x 400mm x 600mm and compact until no further collapse.
2	Supply and install the 1015mmx2480mm, 80mm square tubing support frame in the excavated holes. (Details of the support frame are specified in drawing no A104/100/7). Backfill with 150mm gravel layer
3	Cast concrete around the support frame and temper to ground level as specified and illustrated in drawing no A104/100/7. Cure concrete by wetting and keeping damp
4	Supply and install the two 1230mm high x 2130mm automated cattle sorting gates complete with all the ancillary equipment, gate stopping mechanisms, hinges, extensions and circular guides as illustrated in drawing A104/100/7
5	Supply and install the Pneumatic system and all the compressed air RAMS as specified and illustrated in A104/100/7

PICTORIAL PROCEDURES:

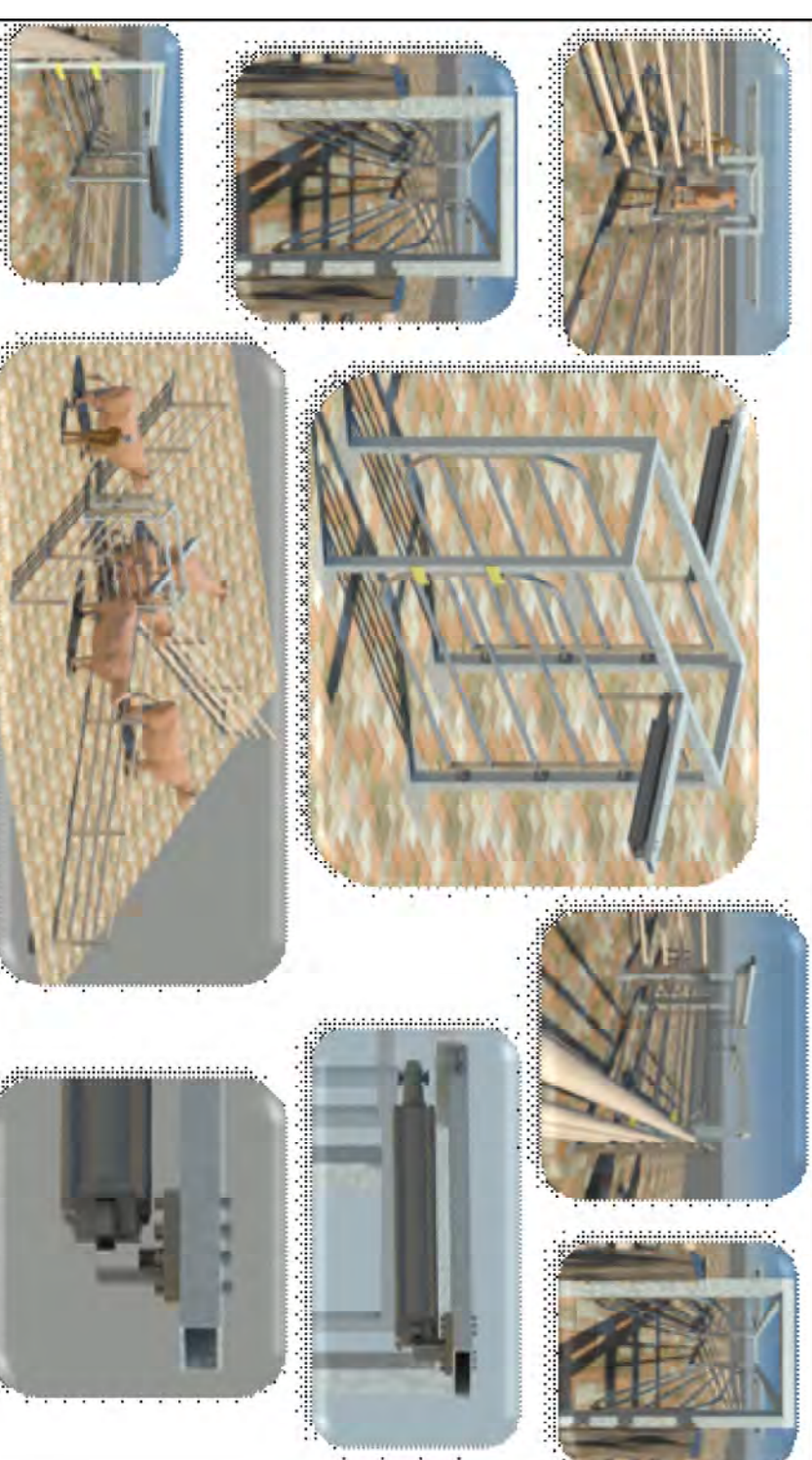

**AGRICULTURAL RESEARCH COUNCIL - Institute for Agricultural Engineering**  
 Agricultural Infrastructure and Engineering Structures Division, Construction Procedure document  
 P Bag X319, Silverton, Pretoria, 0127 +27(0) 12 842 4000 www.aic.ac.za

**INSTITUTE FOR AGRICULTURAL ENGINEERING**  
 AGRICULTURAL RESEARCH COUNCIL

**INSTITUT VIR LANDBOU-INGENIEURSWESIE**  
 LANDBOUWONNERSKAP

**RFID CATTLE HANDLING SYSTEM**  
**AUTOMATED CATTLE SORTING SYSTEM**

SCALE: 1:20  
 DATE: 20 OCT 2010  
 TRK. NR.: 09AMW/NO.

DESIGNER: P. J. BRITZ  
 PROJ. LEADER: P. J. BRITZ  
 CHECKER: P. J. BRITZ  
 DATE: 20 OCT 2010  
 TRK. NR.: 09AMW/NO.

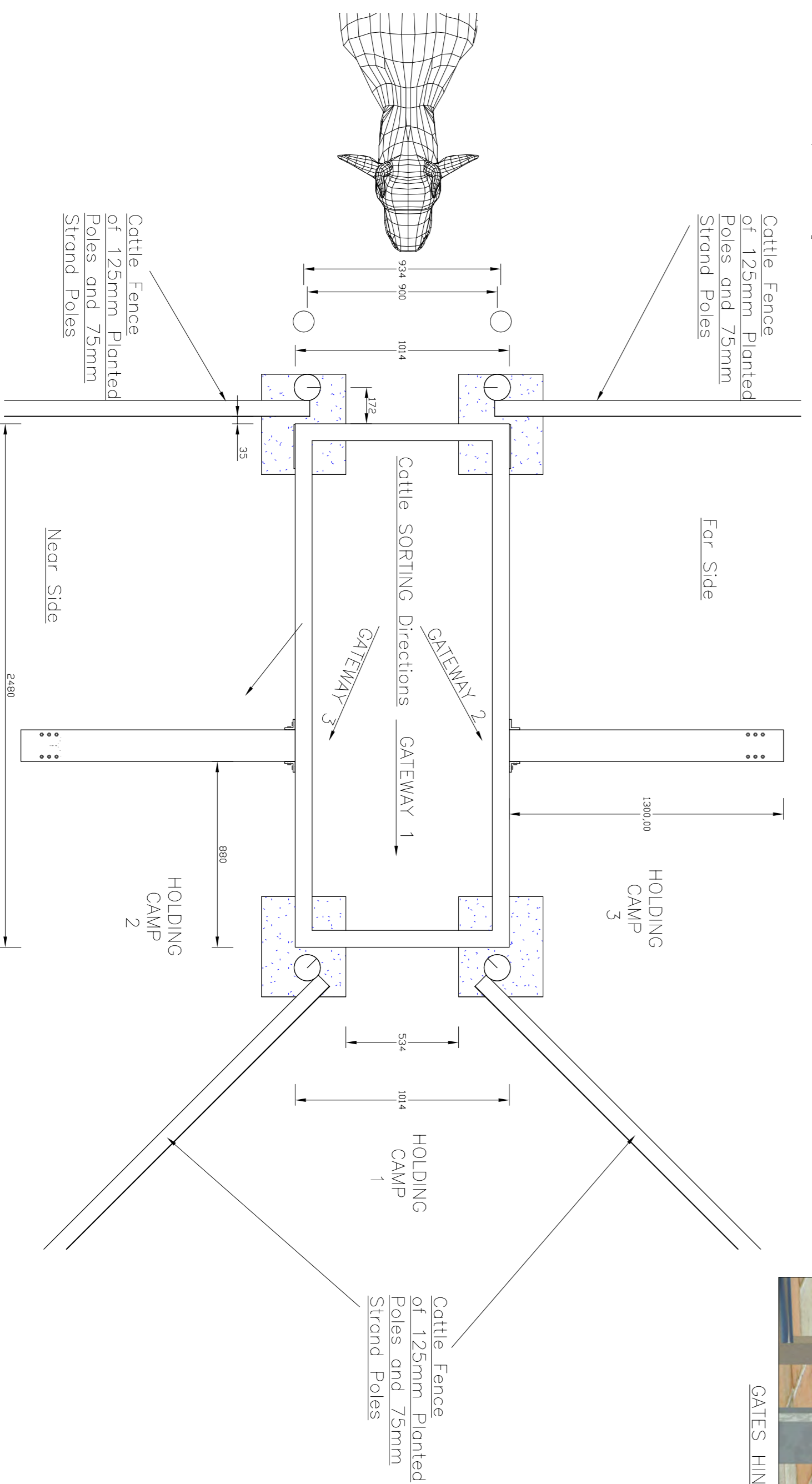

CATTLE SORTING GATE SYSTEM PLAN SCALE 1:20

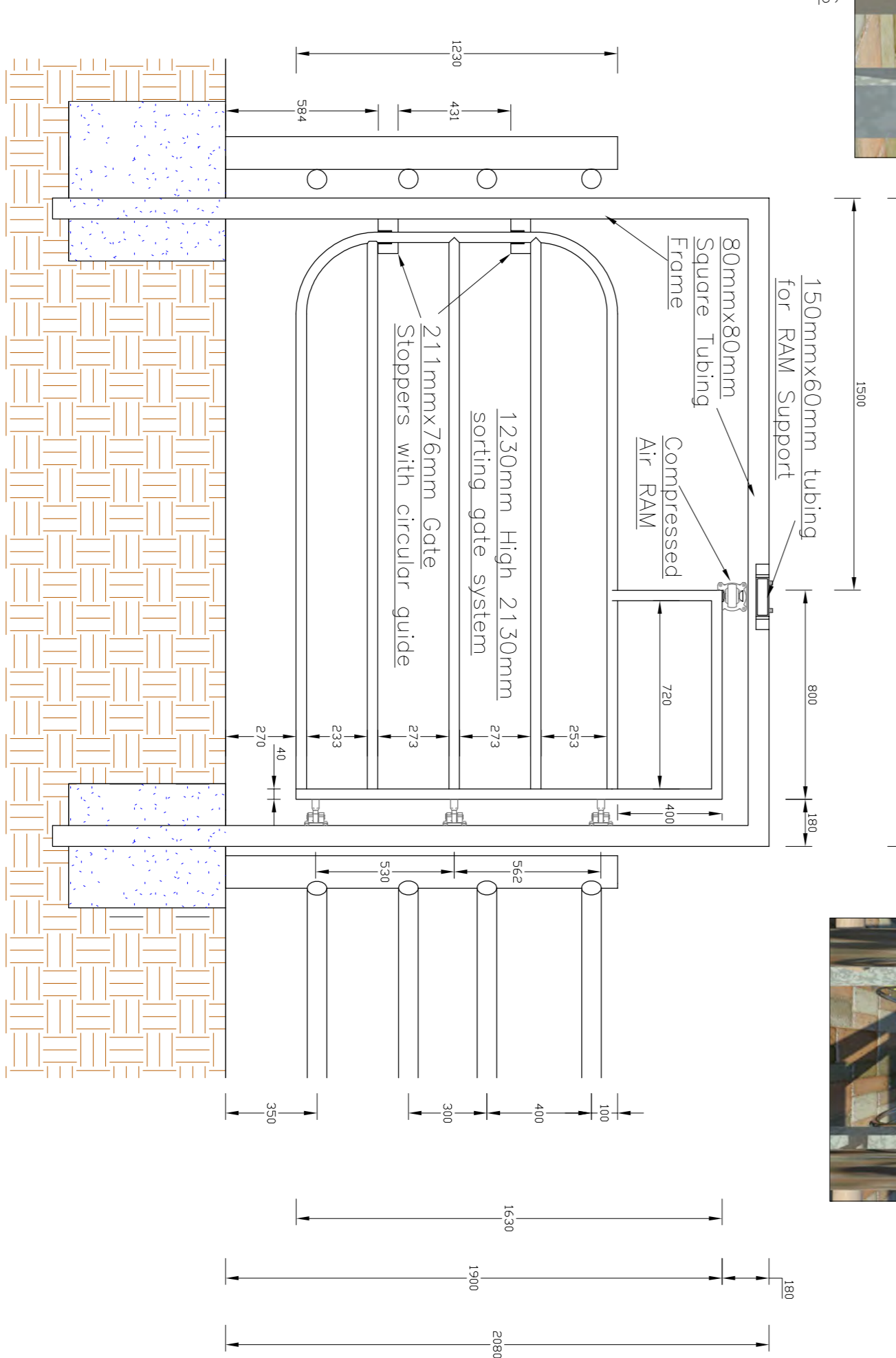

SECTION ALONG PASSAGEWAY SCALE 1:20

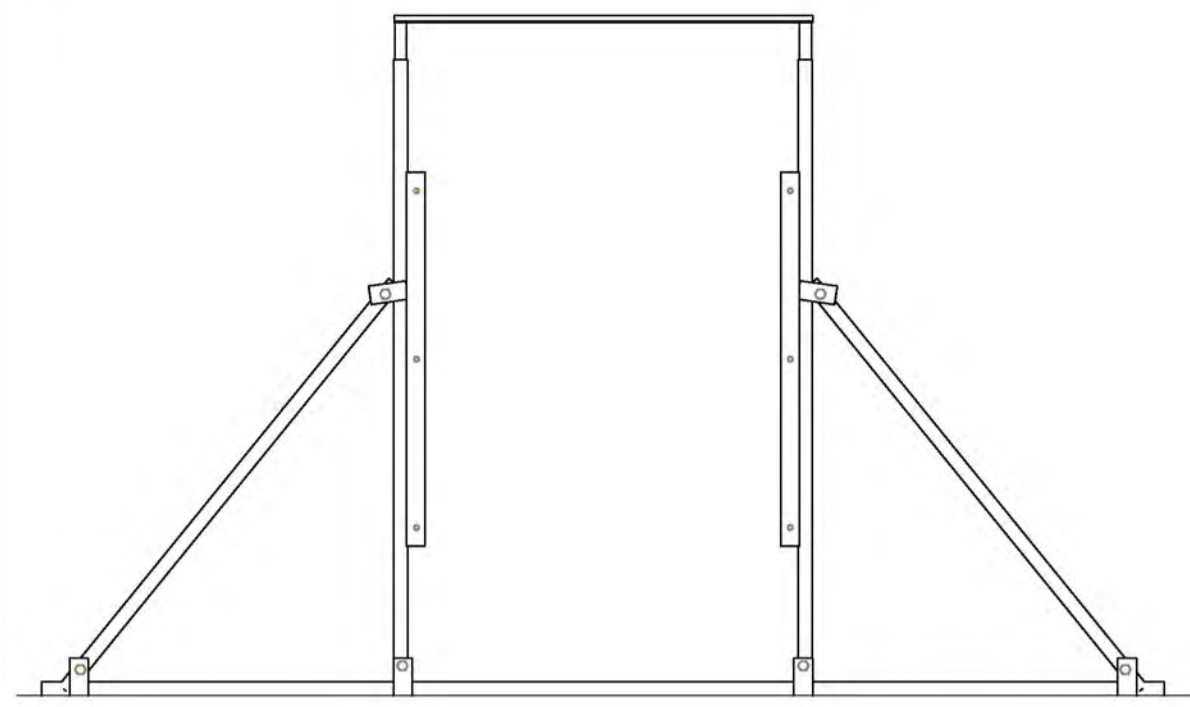

East  
1 : 20

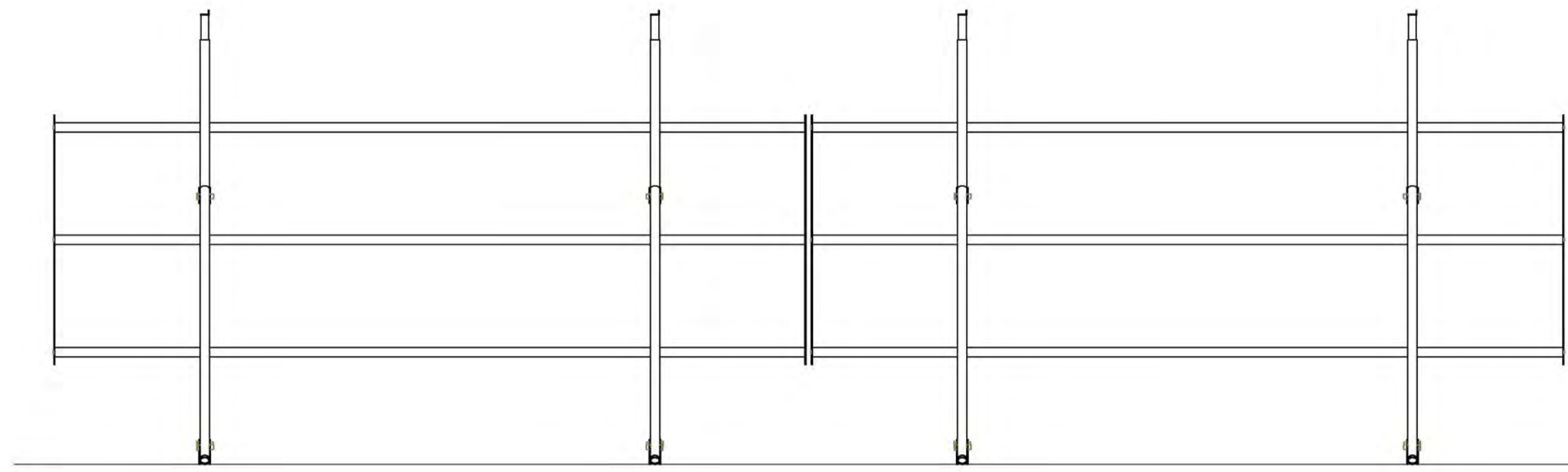

North  
1 : 20

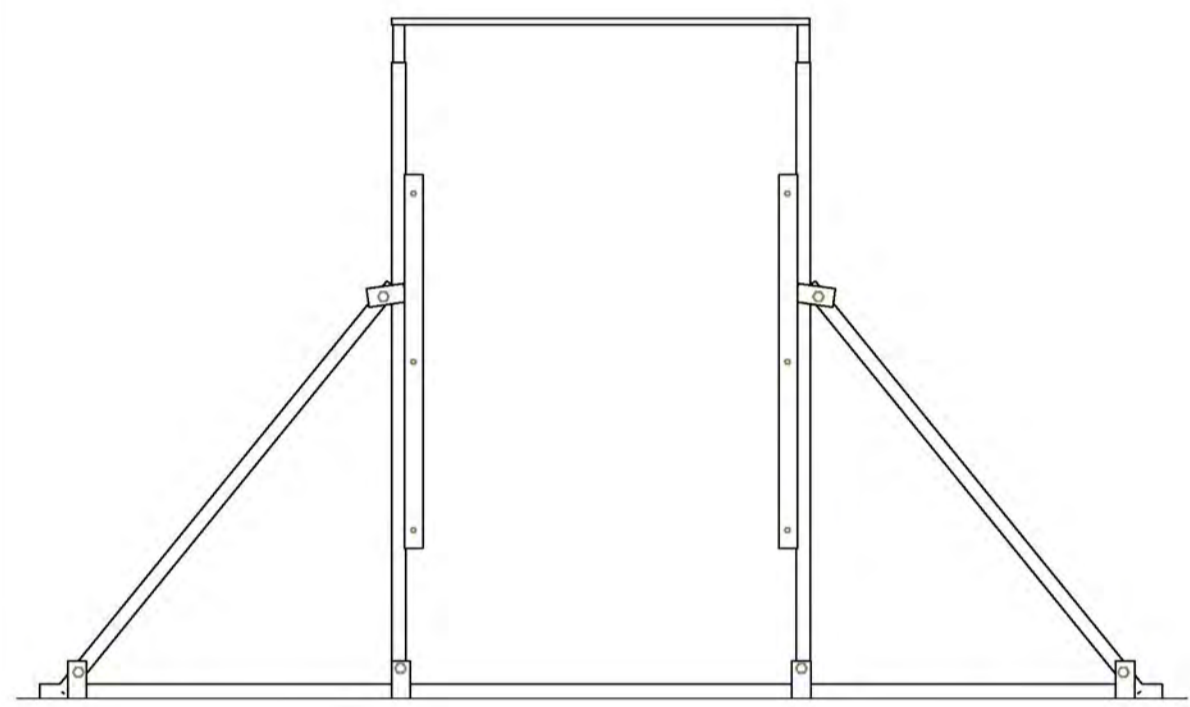

West  
1 : 20

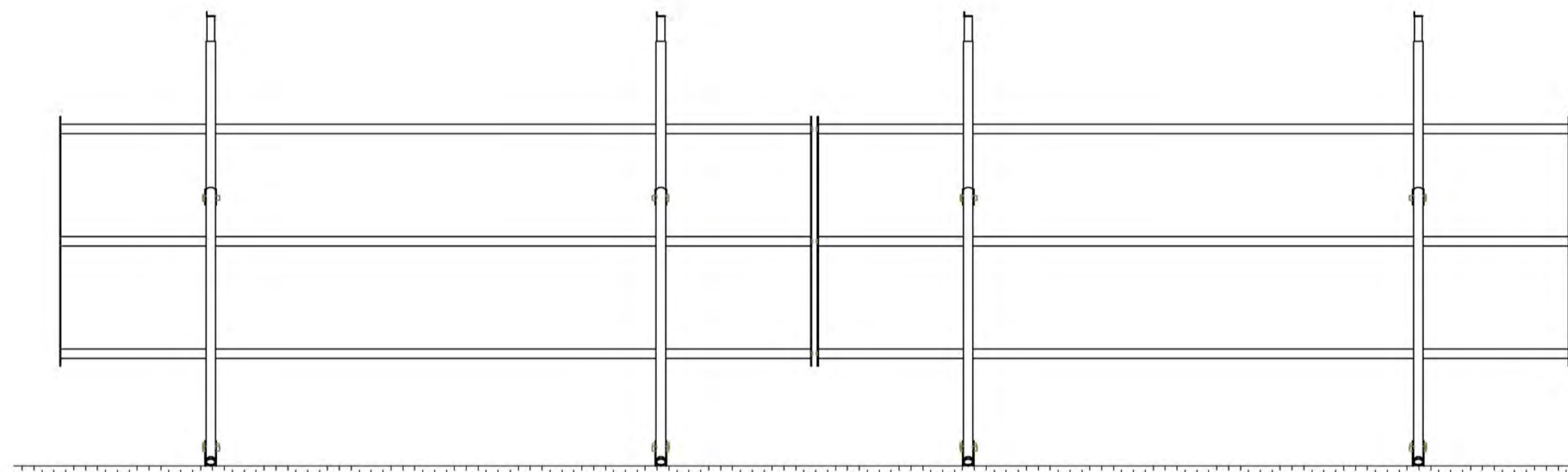

South  
1 : 20

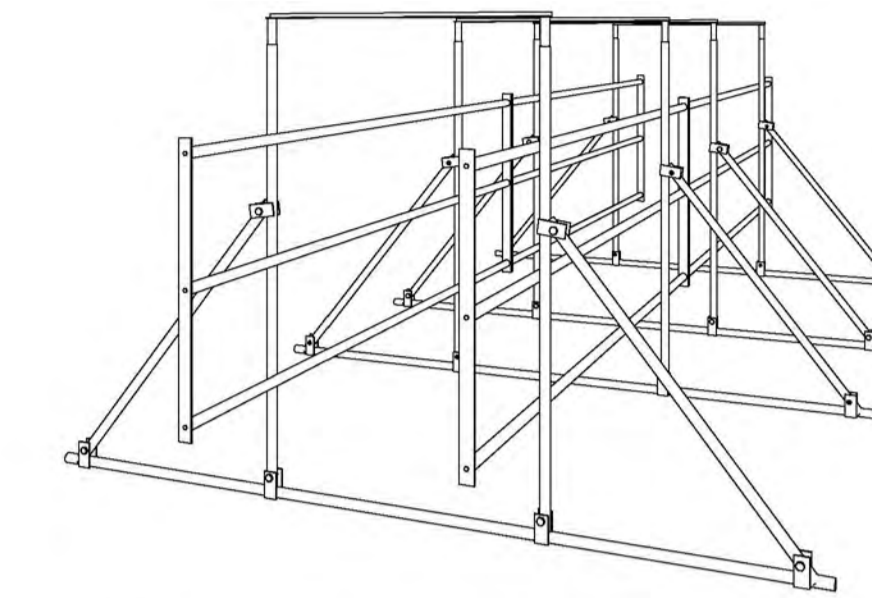

3D View 1

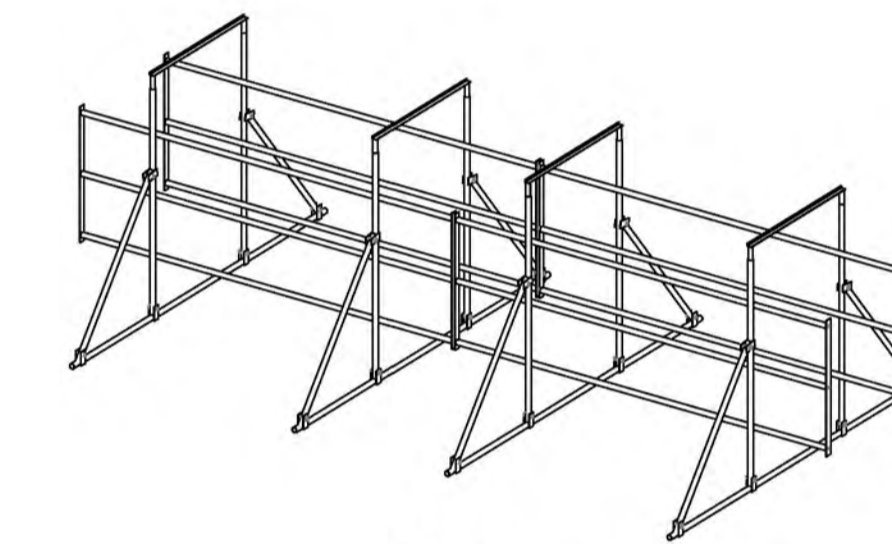

{3D}

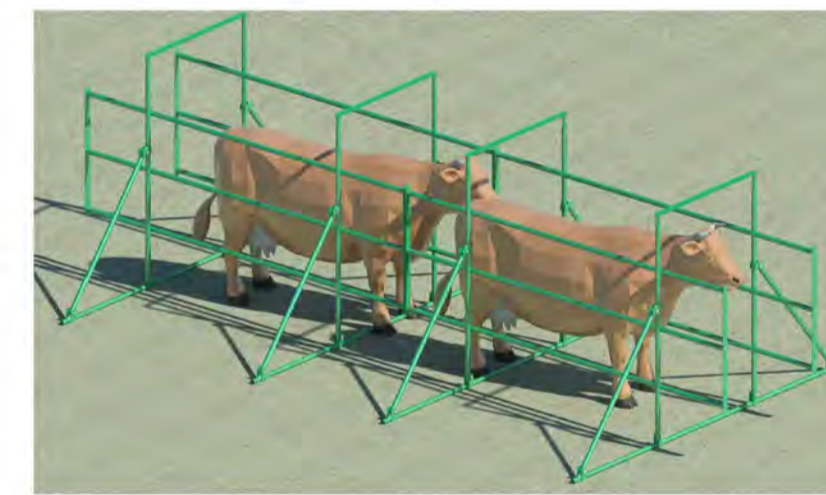

render 1

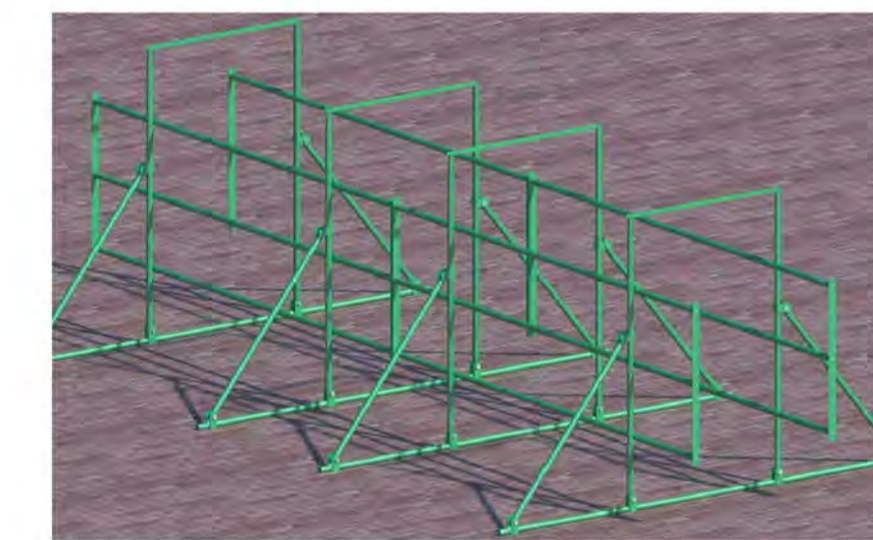

-3D-4

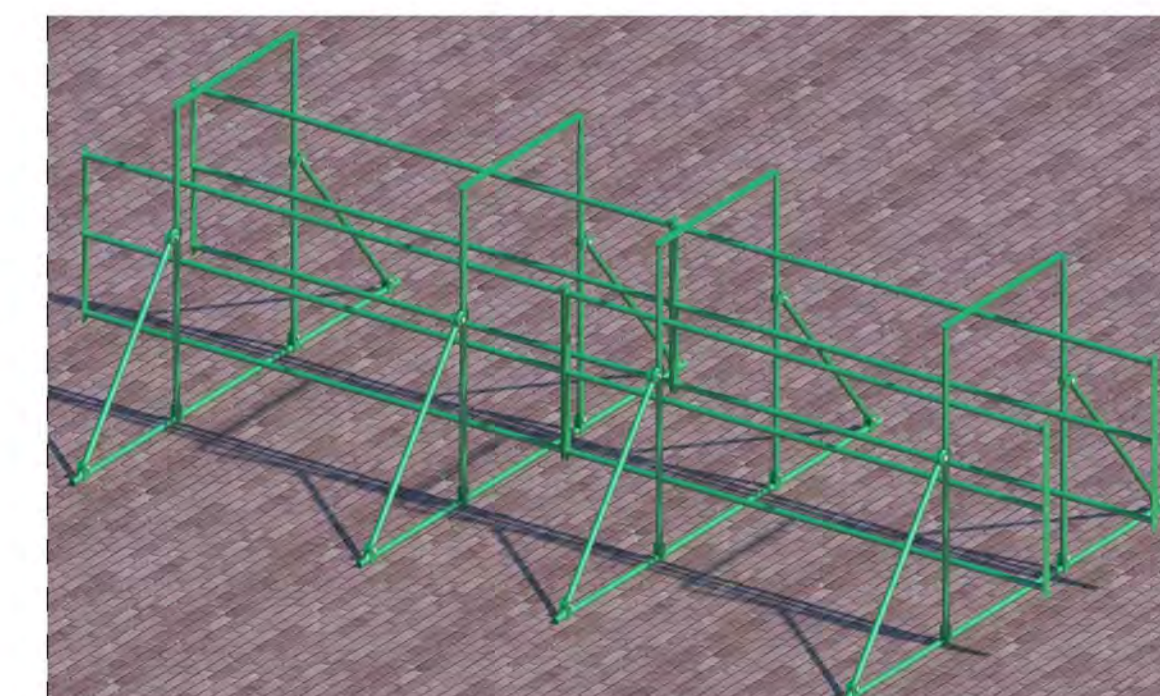
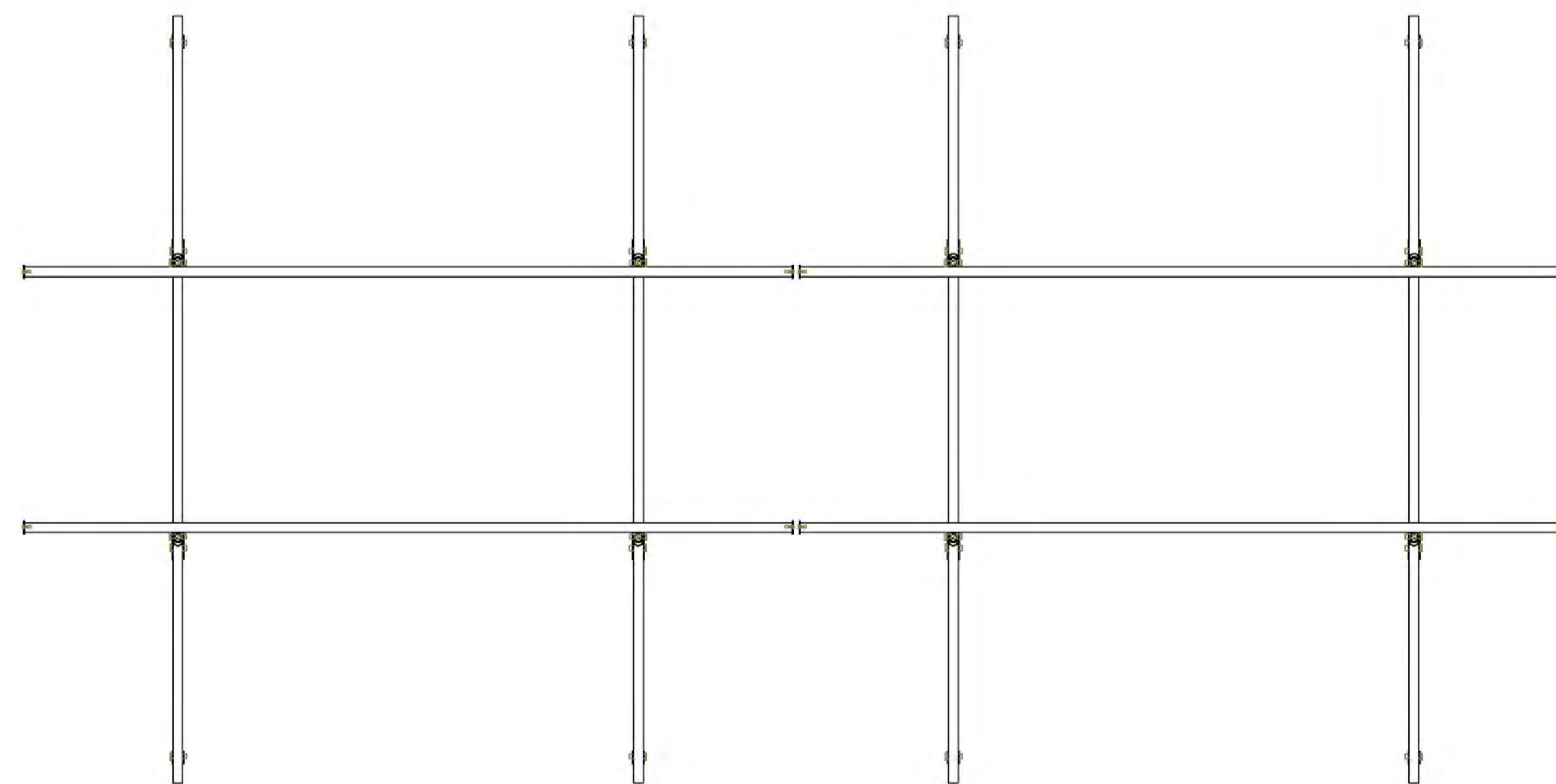

-3D-3



Render camera

<http://beeh.ukzn.ac.za>

No.	Description	Date

**MSc Eng Project**

The Development of an RFID Based Cattle Handling System

1. Cattle Leading Race Passage Alleyway

Project number 209519850

Date 20 October 2011

Designed by Tendai Justin Mutenje

Supervisor Prof Jeff Smithers

1 of 5

Scale As indicated

1 00Ground Level  
1 : 20

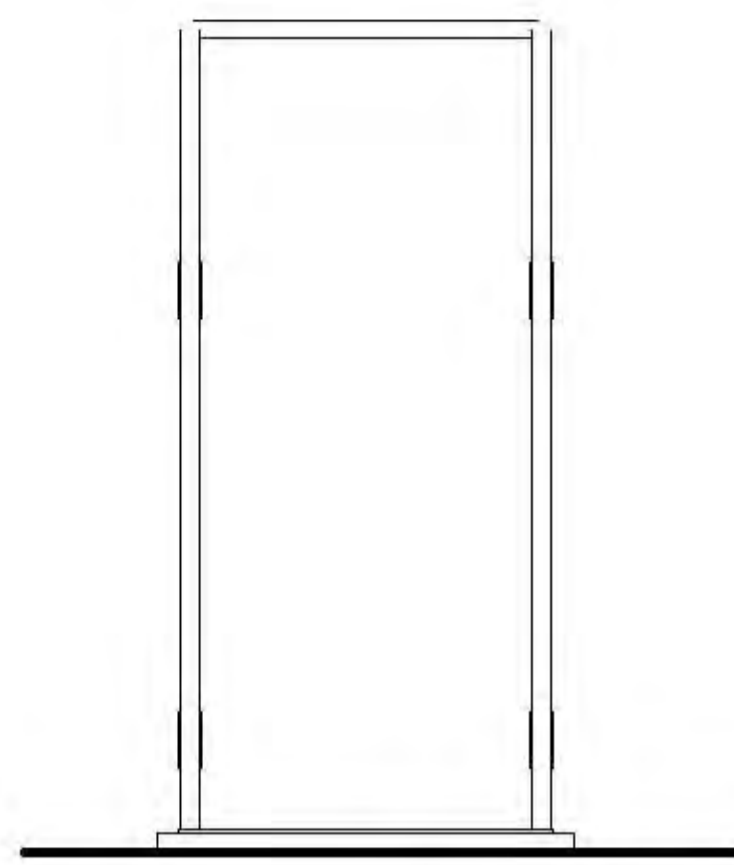

**East**  
1 : 20

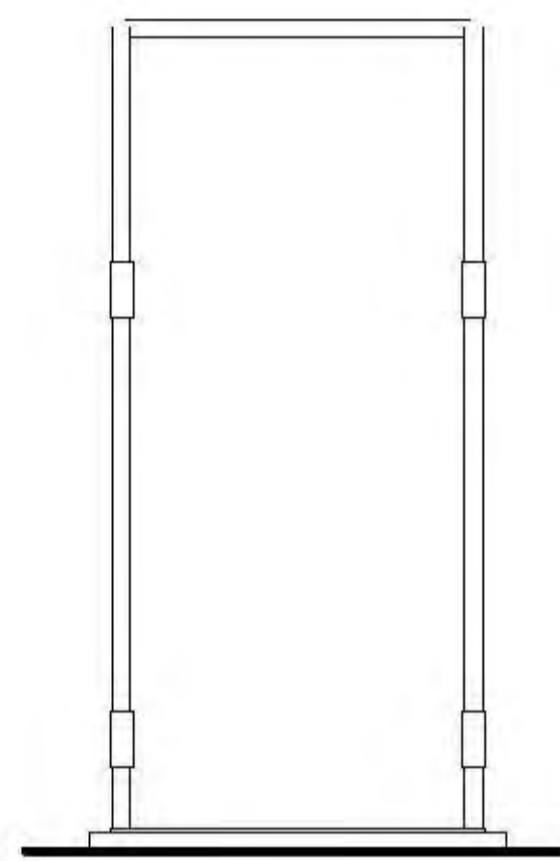

**West**  
1 : 20

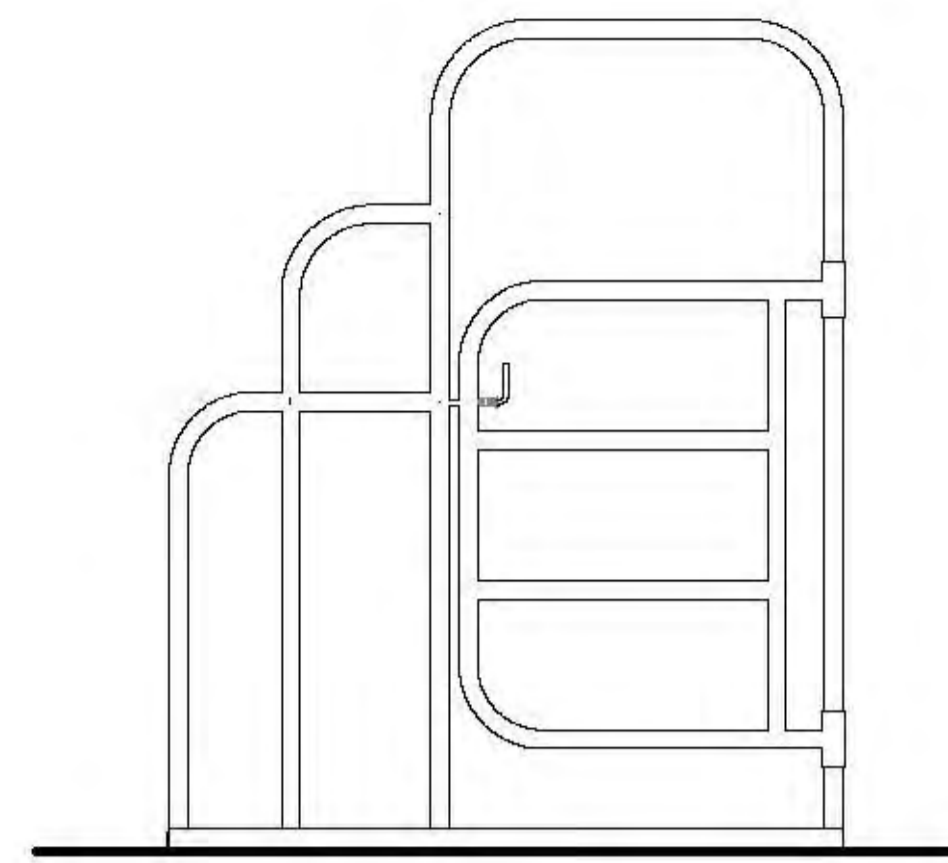

**North**  
1 : 20

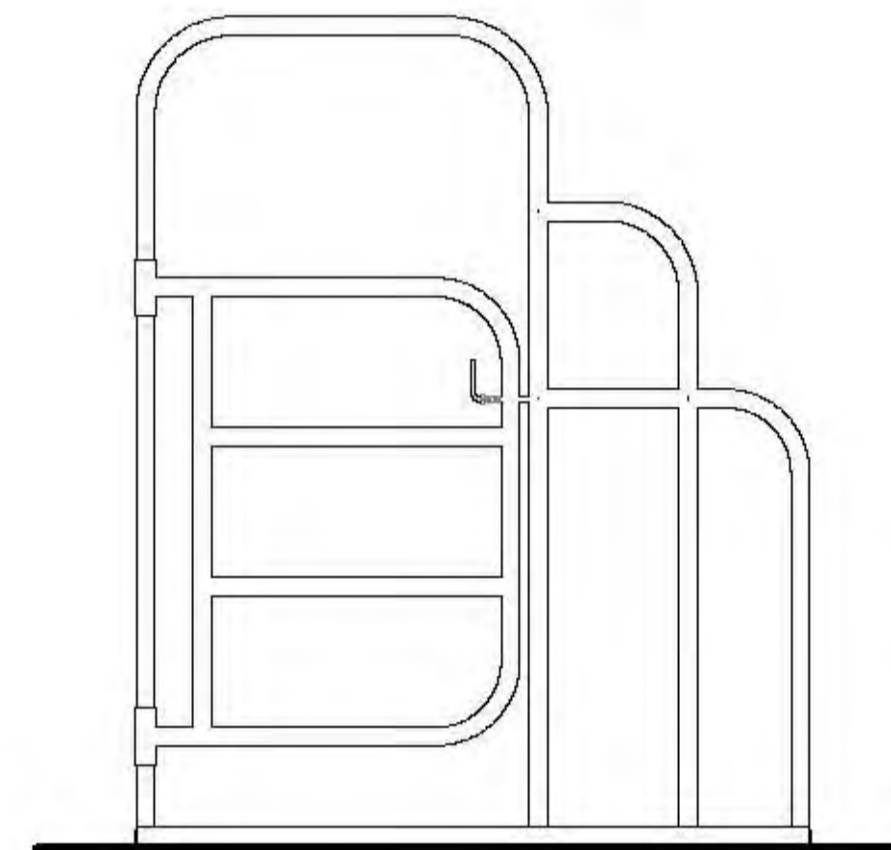

**South**  
1 : 20

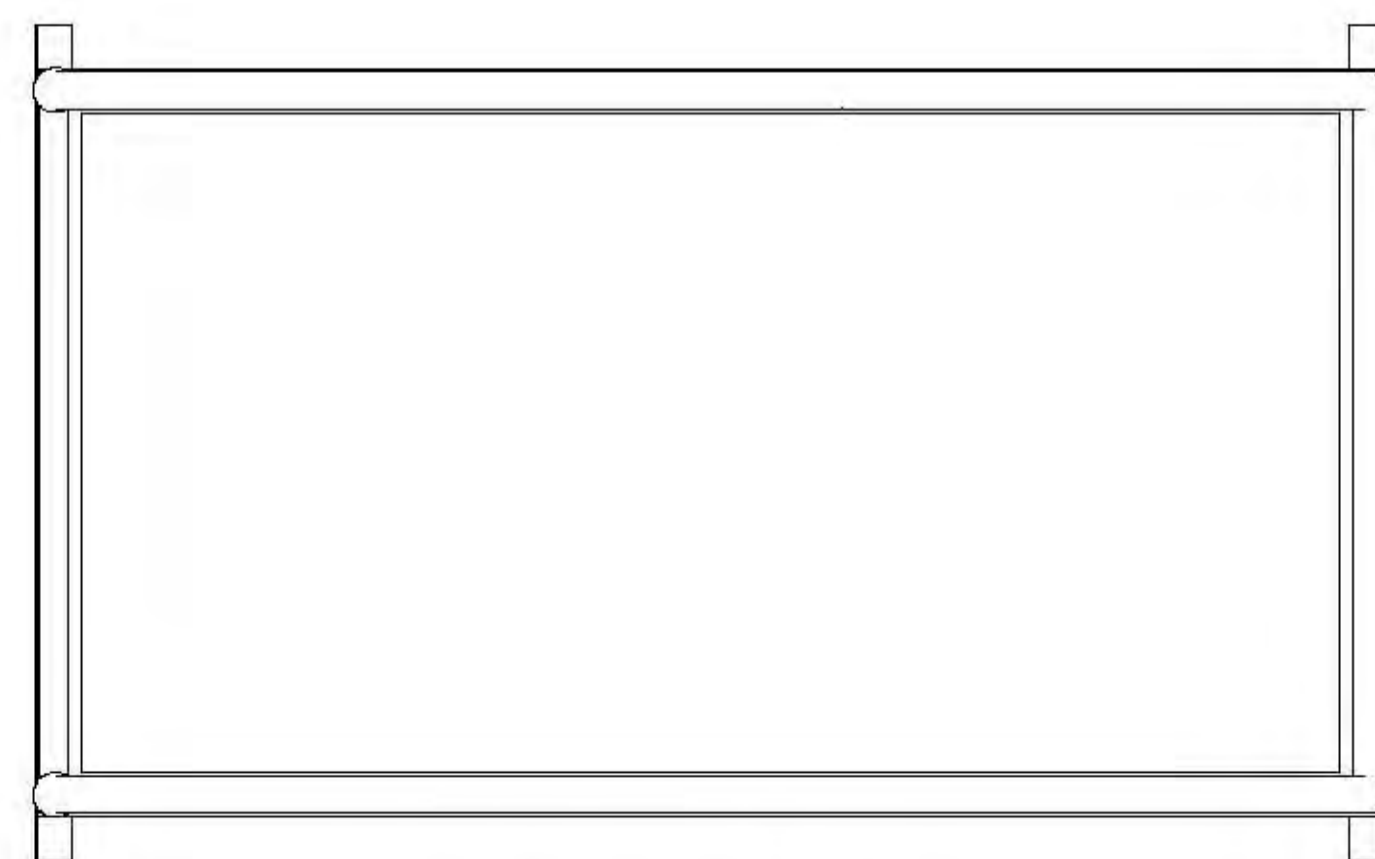

**Ground Level Plan**  
1 : 10

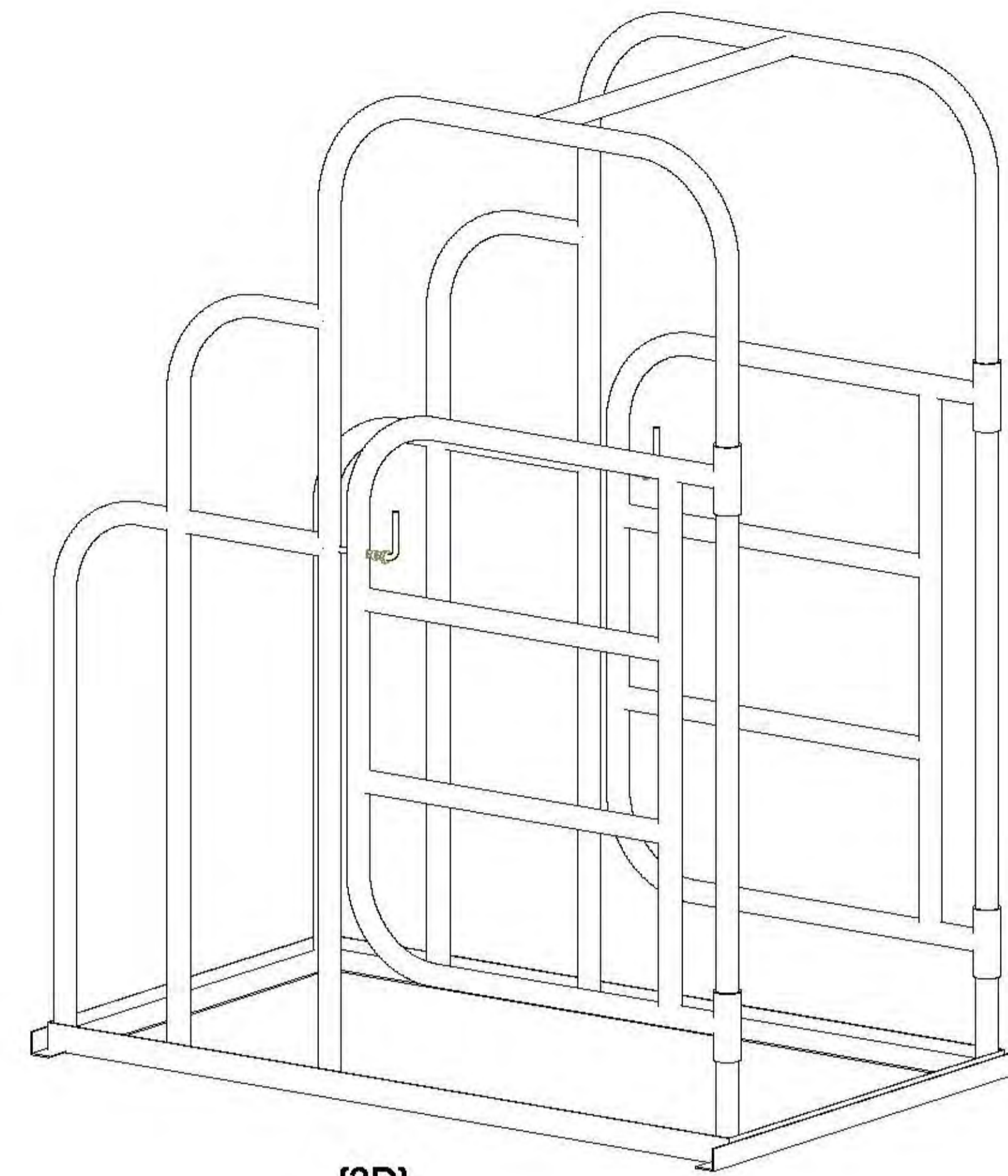

{3D}

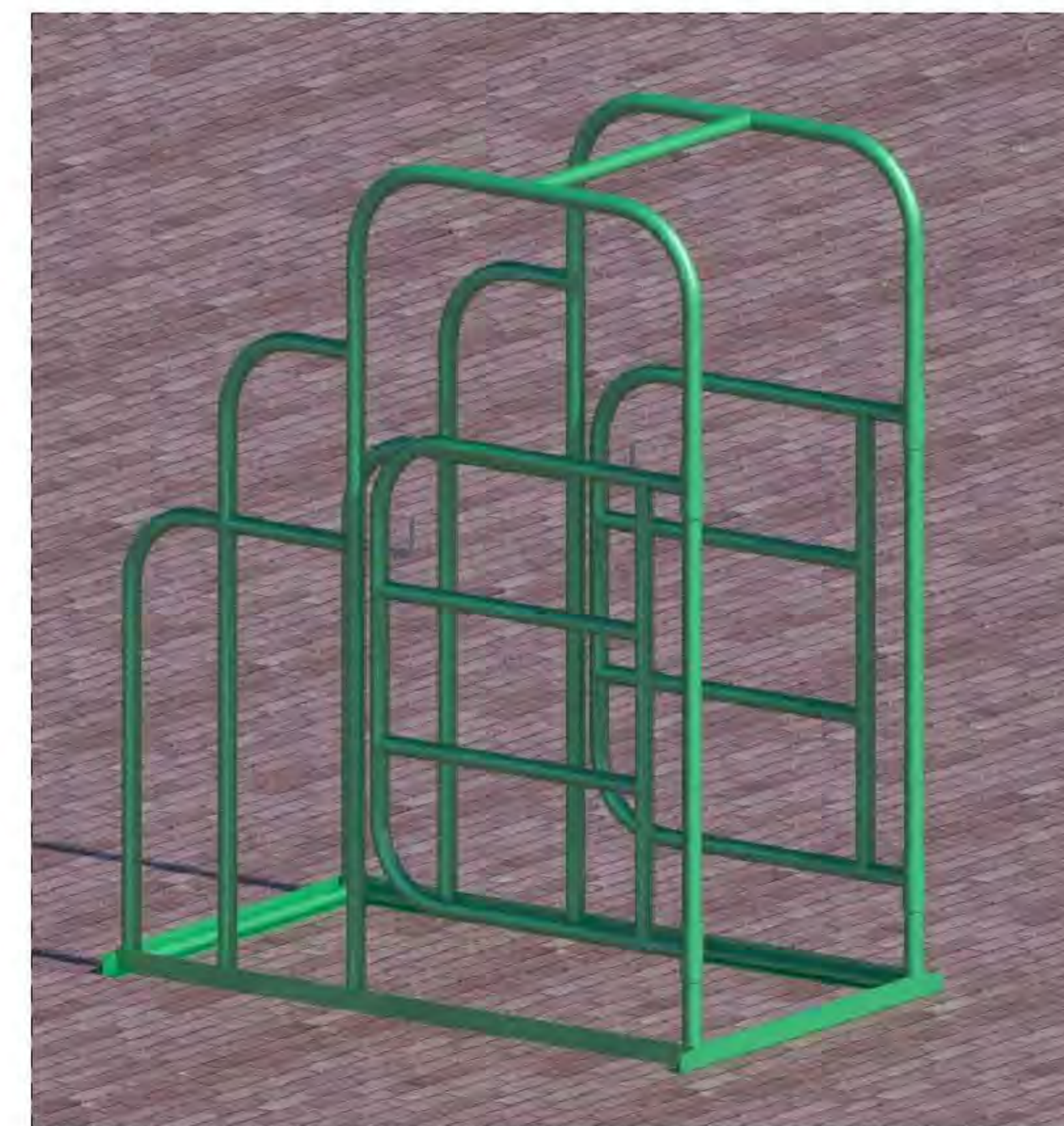

Final render

<http://beeh.ukzn.ac.za>

No.	Description	Date

**Owner**

**Project Name**

Unnamed

Project number    Project Number

Date    Issue Date

Designed by    Author

Supervisor    Checker

A101

Scale    As indicated



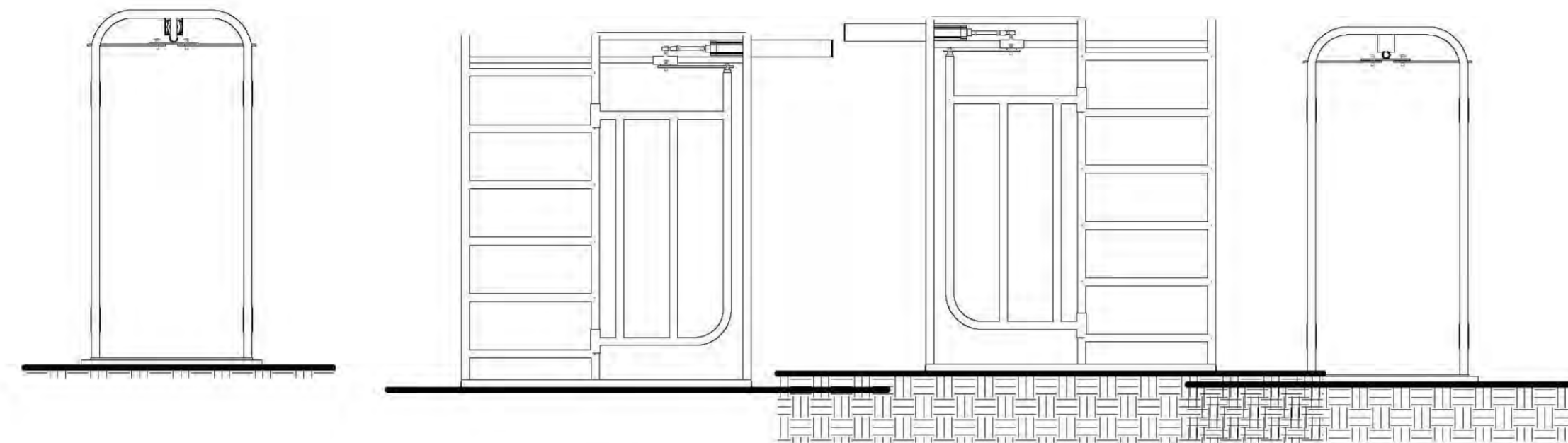

4 East  
1:20

5 North  
1:20

6 South  
1:20

7 West  
1:20

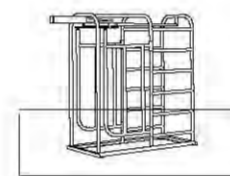

3 3D View 1

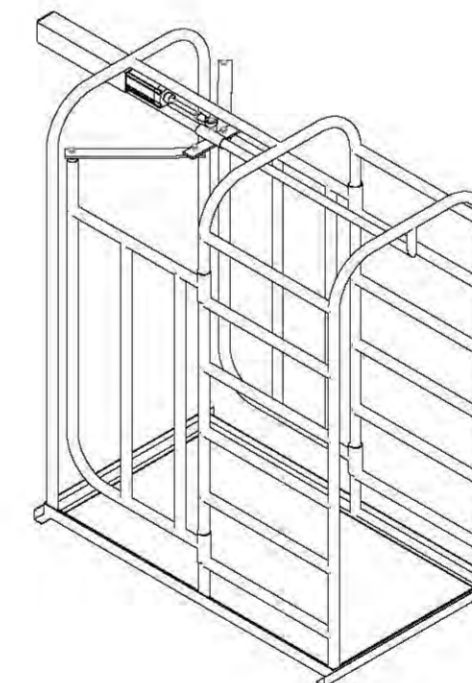
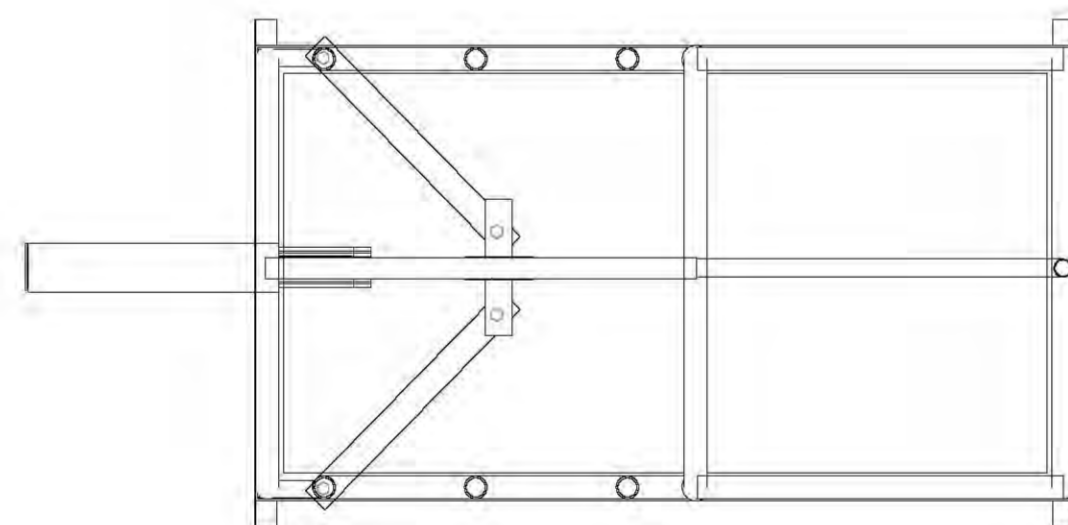

<http://beeh.ukzn.ac.za>

No.	Description	Date

**MSc Eng Project**  
RFID Based cattle  
system

Flow control gates

Project number 208519850

Date 20 October 2011

Designed by Tendai Justin Mutenje

Supervisor by Prof Jeff Smithers

3 of 5

Scale As indicated

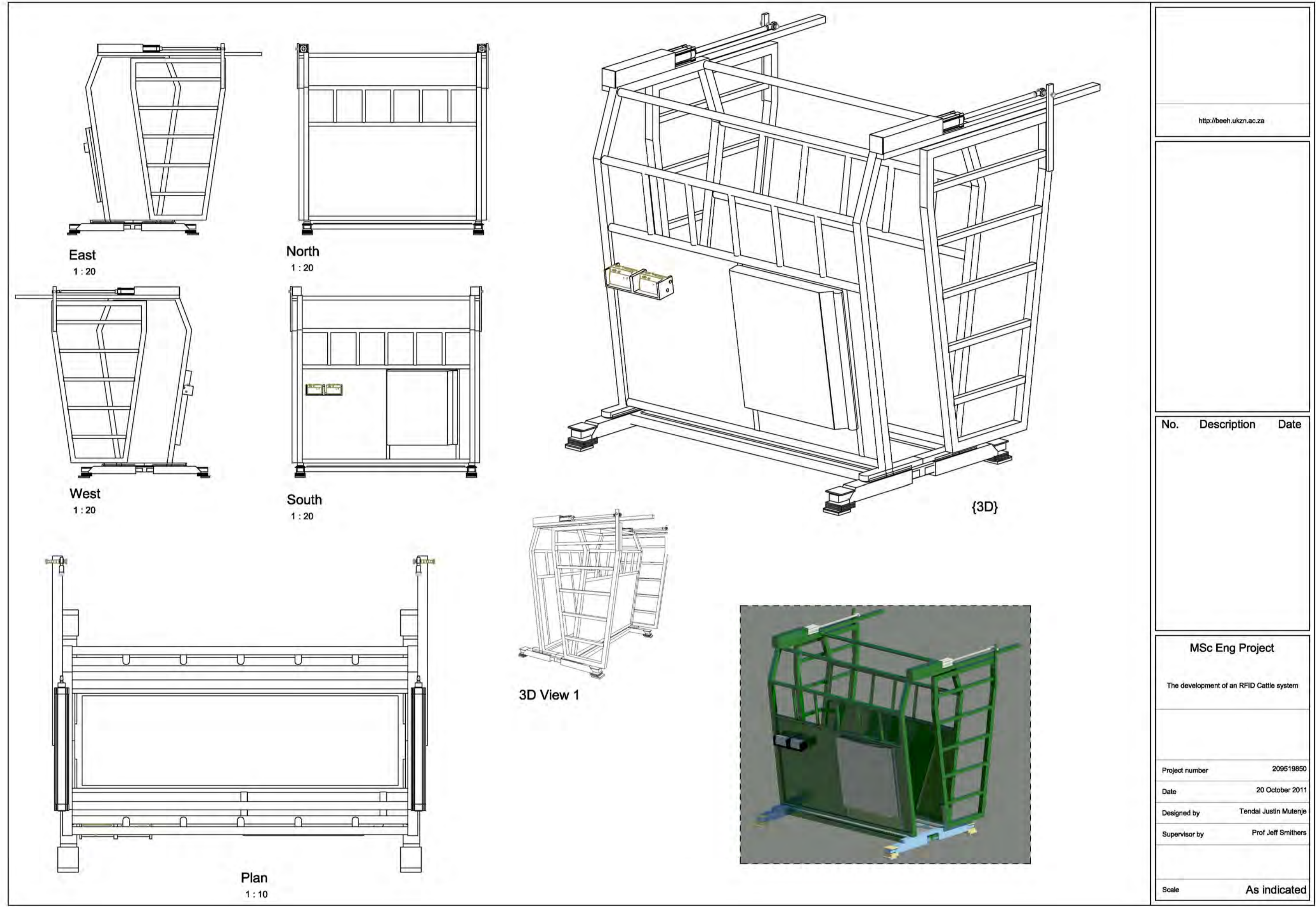

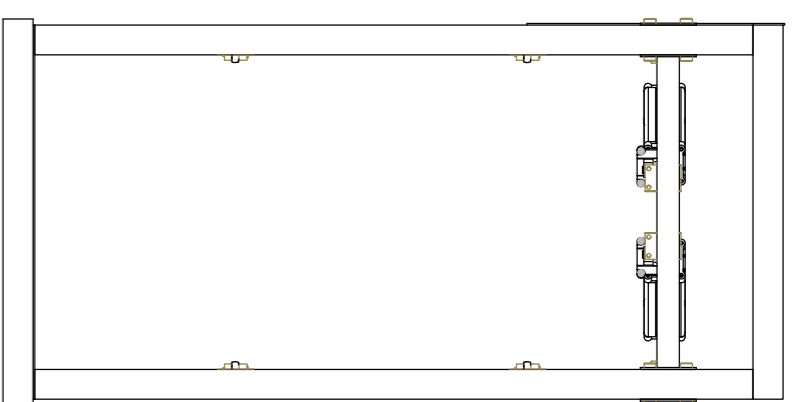

East  
1 : 20

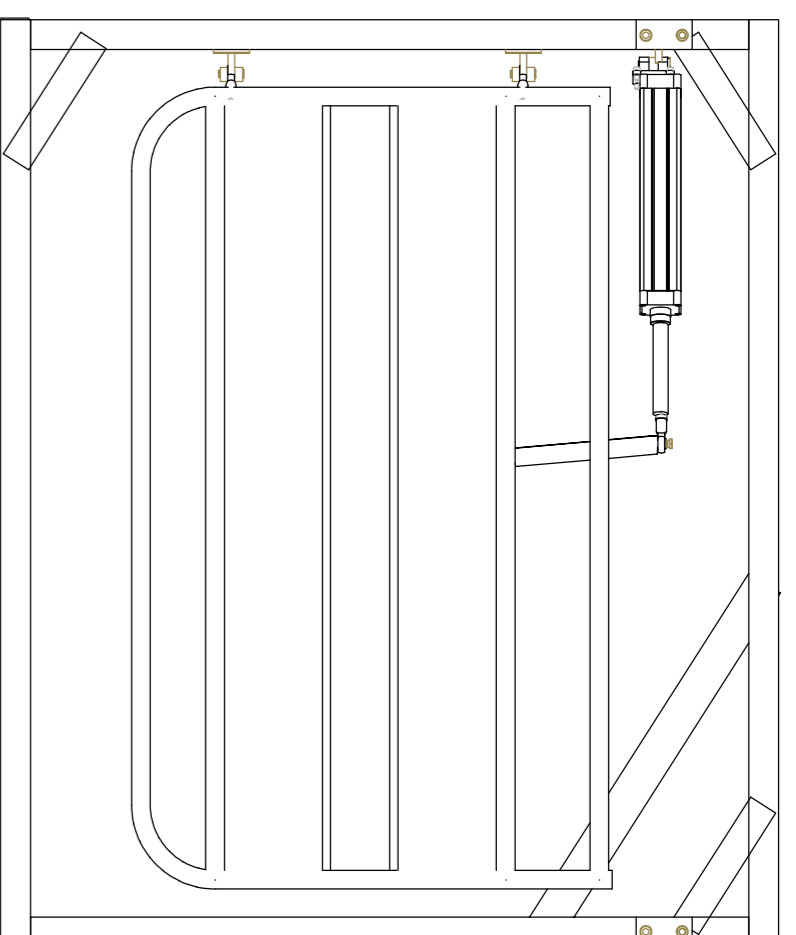

North  
1 : 20

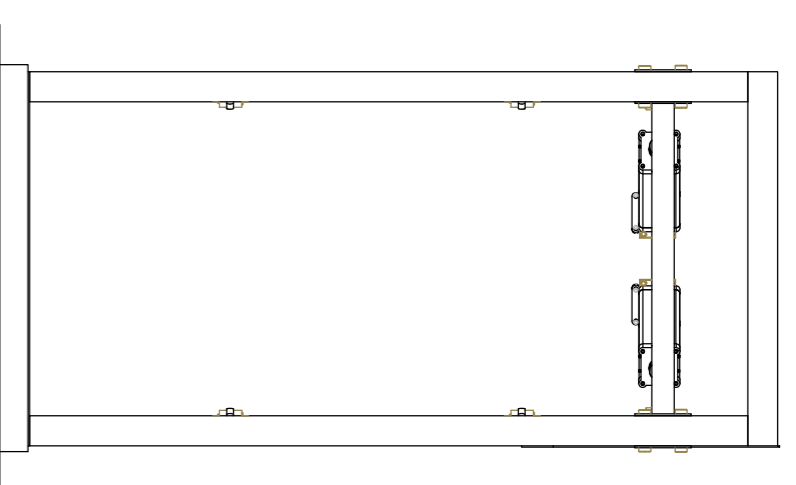

West  
1 : 20

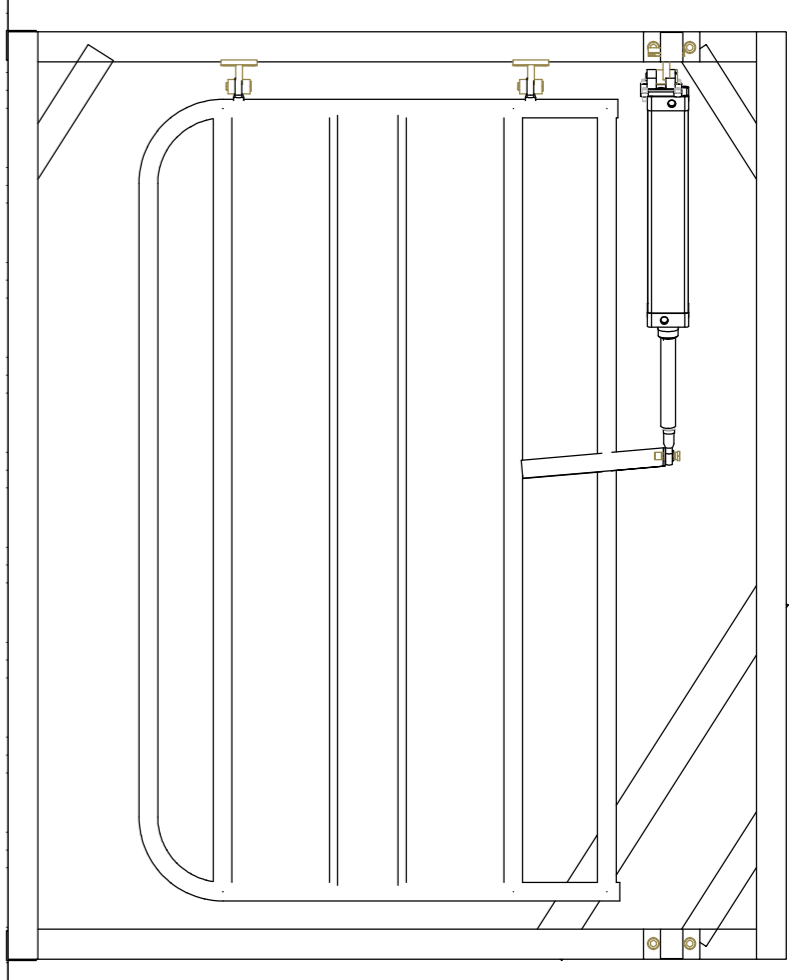

Section 2  
1 : 20

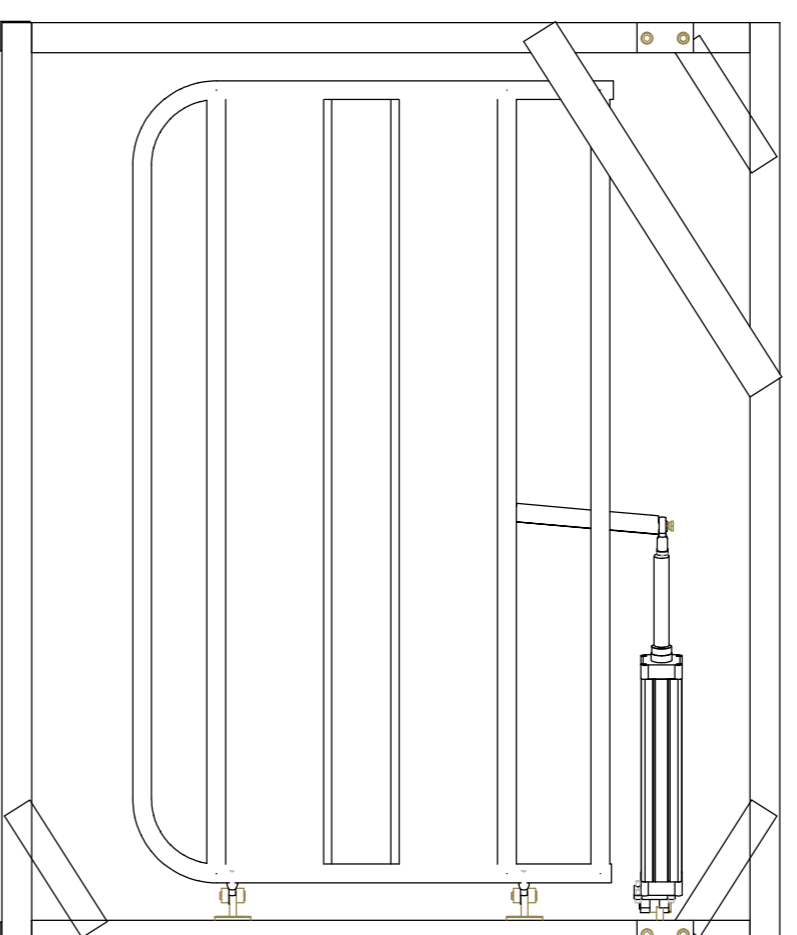

South  
1 : 20

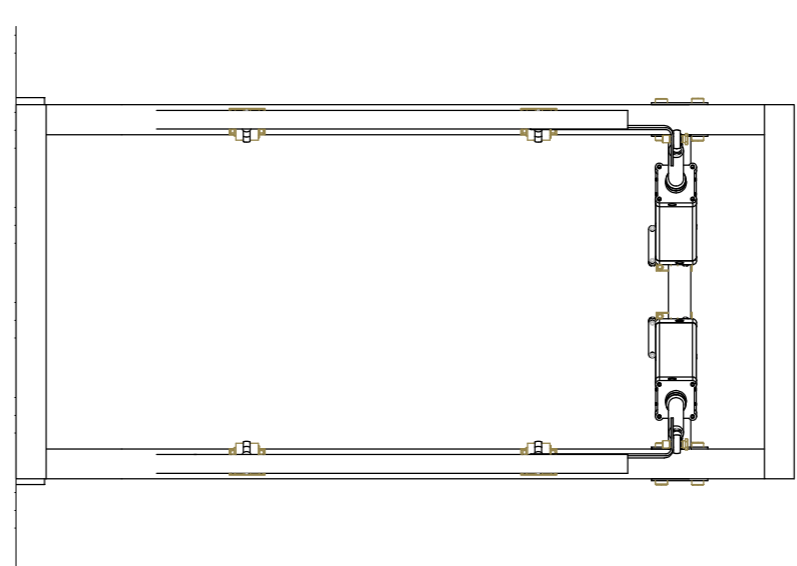

Section 1  
1 : 20

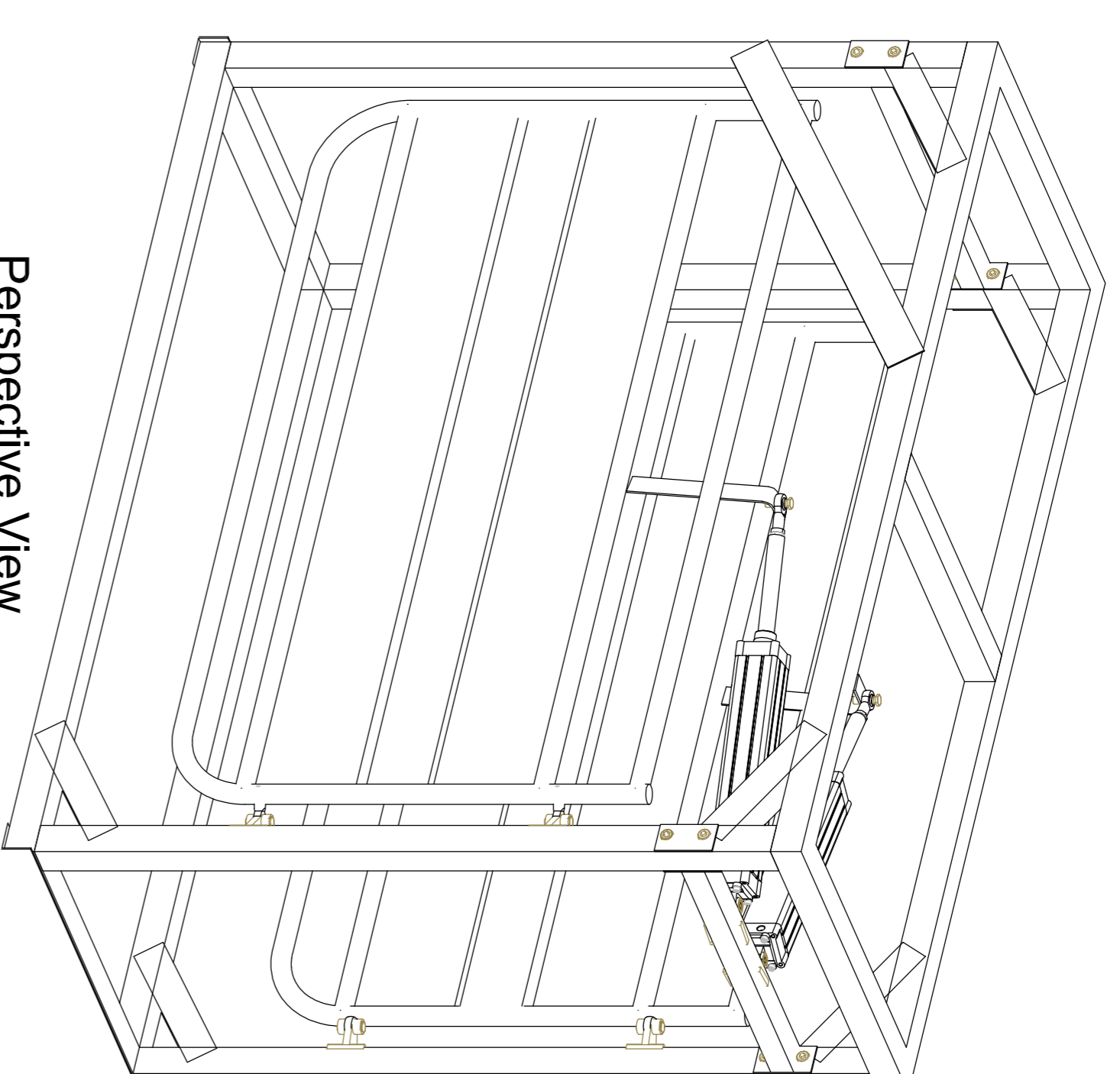

Perspective View

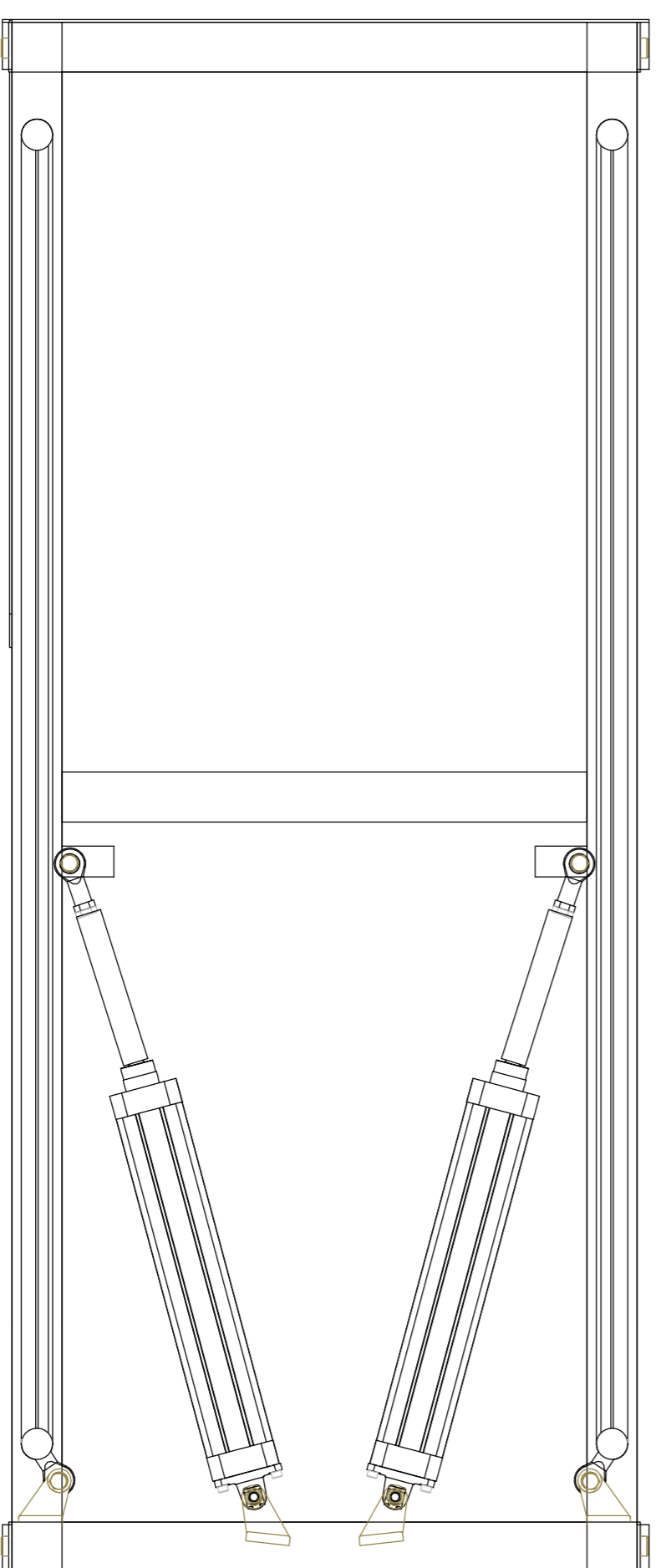

Plan View  
1 : 10

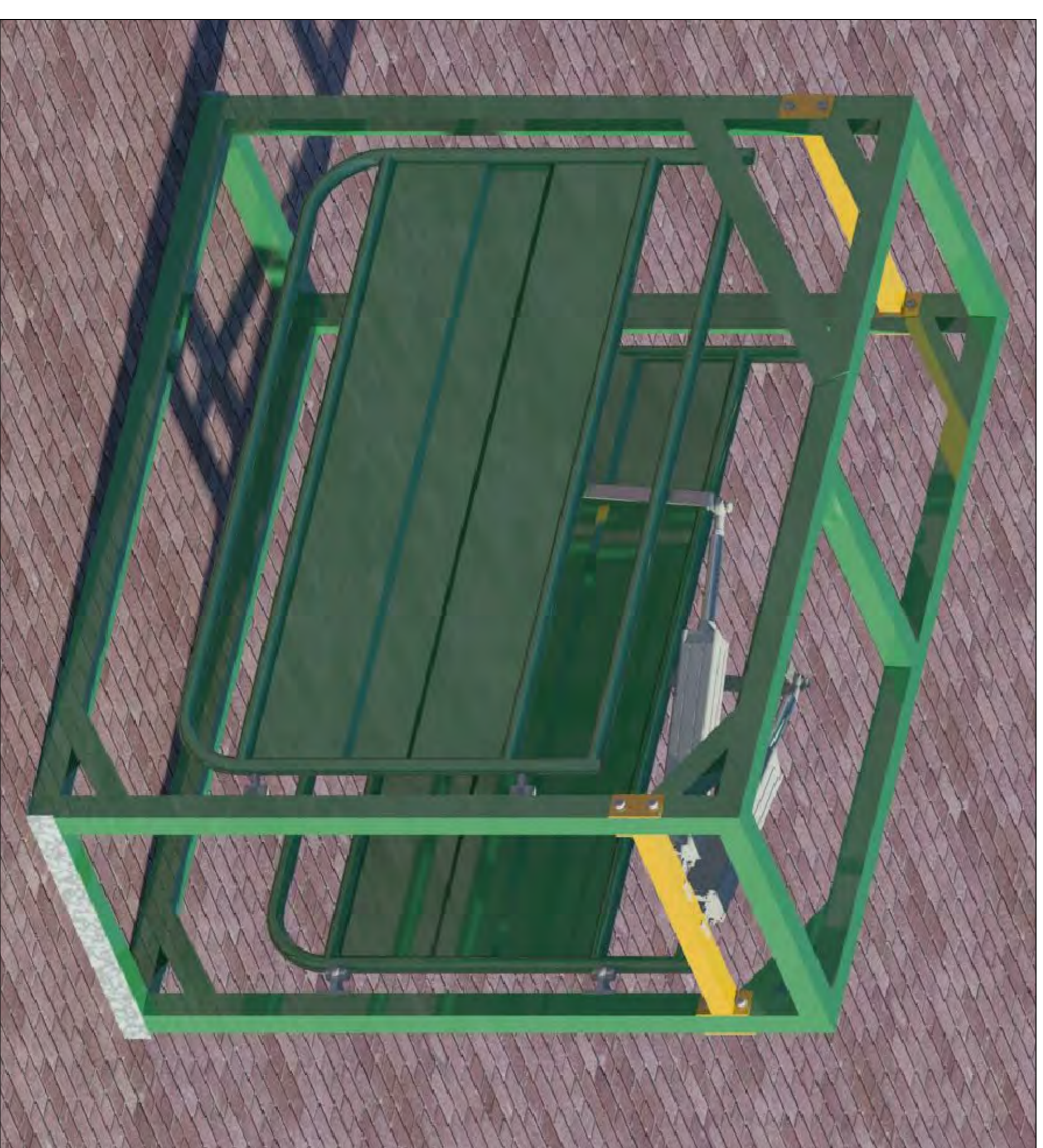

Rendered View of Proposed Structure



<http://beeh.ukzn.ac.za>

SCHOOL OF BIORESOURCES  
ENGINEERING AND  
ENVIRONMENTAL  
HYDROLOGY (BEEH) UKZN

Copyright © 2011, All Rights Reserved. Engineering, Biotechnology, Logistics

PROJECT FUNDED

BY

AGRICULTURAL RESEARCH  
COUNCIL INSTITUTE FOR  
AGRICULTURAL ENGINEERING  
(ARC-IAE), SILVERTON

No.	Description	Date

**MSc Eng Agricultural  
Engineering**

**Project Title:**  
Development of an RFID  
Based Cattle Handling  
System

Drawing No. 6,  
Automated RFID Sorting System

Project number: 209519850

Date: October 2011

Drawn by: Tendal Justin Mutenje

Designed by: Tendal Justin Mutenje

Supervisor: Prof. Jeff Smithers

Scale: As indicated



## APPENDIX E: EVALUATION PROCESS AND OUTPUT DATA

Table 0.1 System evaluation process data collection form

RFID AND MANUAL BASED CATTLE HANDLING DATA COLLECTION AND SYSTEM EVALUATION FORM							
<b>Evaluation Undertaken By:</b>		Tendai Justin Mutenje (Agricultural Engineer)					
<b>Date:</b>	<input style="width: 150px; height: 20px;" type="text"/>	<b>Time:</b>	<input style="width: 150px; height: 20px;" type="text"/>				
<b>Sample No:</b>	<input style="width: 180px; height: 20px;" type="text"/>						
<b>A PERSONAL CHARACTERISTICS</b>							
Characteristics	Unit	Details					
Name of Subject	Full name						
Age	years						
Weight	kg						
<b>B PERSONAL MEASURABLE DETAILS</b>							
Characteristics	Unit	Details					
Blood Pressure	unit						
Pulse	bpm						
Body Temperature	°C						
<b>C EXTERNAL CONDITIONS</b>							
Item No	Details	Before Activity		During Activity		After Activity	
		Manual	RFID	Manual	RFID	Manual	RFID
1	Temp °C						
2	RH %						
Item No	Activity	Time(sec)	Heart rate (bpm)	Breathing frequency			
<b>E INCORRECT SORT CATTLE</b>							

Table 0.2 Day 3 average handling duration results

<b>Handling Area</b>	<b>Average Handling Duration (s)</b>	
	<i>Manual</i>	<i>RFID</i>
Lead Race	5.9	5.7
Flow Control Gates	5.1	1.9
ID -Weigh Box	20.5	4.6
Sorting Gate	10.9	3.3
<b>Total Average</b>	<b>42.4</b>	<b>15.5</b>

Table 0.3 Day 6 average handling duration results

<b>Handling Area</b>	<b>Average Handling Duration (s)</b>	
	<i>Manual</i>	<i>RFID</i>
Lead Race	5.4	5.2
Flow Control Gates	4.6	1.8
ID -Weigh Box	18.7	4.2
Sorting Gate	9.9	3.1
<b>Total Average</b>	<b>38.6</b>	<b>14.3</b>

Table 0.4 Day 10 average handling duration results

<b>Handling Area</b>	<b>Average Handling Duration (s)</b>	
	<i>Manual</i>	<i>RFID</i>
Lead Race	4.5	4.3
Flow Control Gates	3.8	1.5
ID -Weigh Box	15.5	3.5
Sorting Gate	8.3	2.5
<b>Total Average</b>	<b>32.1</b>	<b>11.8</b>

Table 0.5 Sessional total handling duration for the developed system

Test Day	Handling Duration	
	Manual	RFID
1	1151.94	456.1
2	1101.08	402.9
3	1078.19	392.8
4	1022.25	362.4
5	1004.45	359.8
6	981.563	359.8
7	821.36	301.5
8	828.989	304.1
9	823.903	301.5
10	816.274	299
<b>Total</b>	<b>9630</b>	<b>3540</b>
<i>Mean</i>	<i>963</i>	<i>354</i>

Table 0.6 Handler work physiology data obtained from systems evaluation

Test Day	Handling Duration		Heart rate		Energy expenditure		TCCW		PCW	
	Manual	RFID	Manual	RFID	Manual	RFID	Manual	RFID	Manual	RFID
1	45.3	18	138.0	122.8	11.22	8.03	901.39	741.27	21.94	16.93
2	43.3	15.9	131.9	108.5	10.72	7.09	861.60	708.54	20.97	16.18
3	42.4	15.5	129.1	105.7	10.50	6.91	843.69	693.82	20.53	15.84
4	40.2	14.3	122.4	97.6	9.96	6.38	799.91	657.82	19.47	15.02
5	39.5	14.2	120.3	96.9	8.56	6.33	785.98	646.36	19.13	14.76
6	38.6	14.2	117.6	96.9	9.56	6.33	768.08	631.64	18.69	14.42
7	32.3	11.9	98.4	81.2	8.00	5.31	642.72	528.54	15.64	12.07
8	32.6	12	99.3	81.9	8.07	5.35	648.69	533.45	15.79	12.18
9	32.4	11.9	98.7	81.2	8.03	5.31	644.71	530.18	15.69	12.11
10	32.1	11.8	97.8	80.5	7.95	5.26	638.74	525.27	15.55	11.99
<b>Total</b>	<b>378.7</b>	<b>139.7</b>	<b>1153.4</b>	<b>953.1</b>	<b>92.57</b>	<b>62.30</b>	<b>7535.50</b>	<b>6196.90</b>	<b>183.40</b>	<b>141.50</b>
<i>Mean</i>	<i>37.87</i>	<i>13.97</i>	<i>115.3</i>	<i>95.3</i>	<i>9.26</i>	<i>6.23</i>	<i>753.55</i>	<i>619.69</i>	<i>18.34</i>	<i>14.15</i>

Table 0.7 Cattle work physiology data obtained from systems evaluation

Test Day	Breathing Frequency		Heart rate	
	Manual	RFID	Manual	RFID
1	15.5	14.7	113.5	108.0
2	14.8	13.0	108.5	95.4
3	14.5	12.6	106.3	93.0
4	13.7	11.7	100.7	85.8
5	13.5	11.6	99.0	85.2
6	13.2	11.6	96.7	85.2
7	11.0	9.7	81.0	71.4
8	11.1	9.8	81.7	72.0
9	11.1	9.7	81.2	71.4
10	11.0	9.6	80.4	70.8
<b>Total</b>	<b>129.2</b>	<b>114.0</b>	<b>949.1</b>	<b>838.2</b>
<i>Mean</i>	<i>12.9</i>	<i>11.4</i>	<i>94.9</i>	<i>83.8</i>



Paired t test			
Does the mean of the differences between Manual systems and Automated systems differ significantly from zero?			
<u>P value</u>			
The two-tailed P value is < 0.0001, considered extremely significant.			
t = 24.353 with 9 degrees of freedom.			
<u>95% confidence interval</u>			
Mean difference = 23.900 (Mean of paired differences)			
The 95% confidence interval of the difference: 21.680 to 26.120			
<u>Assumption test: Was the pairing effective?</u>			
Correlation coefficient (r) = 0.9760			
The one-tailed P value is < 0.0001, considered extremely significant.			
Effective pairing results in a significant correlation between the columns.			
With these data, the pairing (or matching) appears to be effective.			
<u>Assumption test: Are the differences sampled from a Gaussian distribution?</u>			
The paired t test assumes that the differences are sampled from a Gaussian distribution. This assumption is tested using the method of Kolmogorov and Smirnov:			
The Kolmogorov-Smirnov distance (KS) is 0.26			
The P value is 0.0618The data passed the normality test with P>0.05.			
Summary of Data			
Parameter:	Manual systems	Automated systems	Difference
Mean:	37.870	13.970	23.900
# of points:	10	10	10
Std deviation:	5.119	2.100	3.103
Std error:	1.619	0.6640	0.9814
Minimum:	32.100	11.800	20.300
Maximum:	45.300	18.000	27.400
Median:	39.050	14.200	24.850
Lower 95% CI:	34.208	12.468	21.680
Upper 95% CI:	41.532	15.472	26.120
	*	*	*

Figure 0.1 Significance test results extract from Graph Pad InStat software

Paired t test			
Does the mean of the differences between Manual Heart RT and RFID Heart Rate differ significantly from zero?			
<u>P value</u>			
The two-tailed P value is < 0.0001, considered extremely significant.			
t = 18.169 with 9 degrees of freedom.			
<u>95% confidence interval</u>			
Mean difference = 20.030 (Mean of paired differences)			
The 95% confidence interval of the difference: 17.536 to 22.524			
<u>Assumption test: Was the pairing effective?</u>			
Correlation coefficient (r) = 0.9763			
The one-tailed P value is < 0.0001, considered extremely significant.			
Effective pairing results in a significant correlation between the columns.			
With these data, the pairing (or matching) appears to be effective.			
<u>Assumption test: Are the differences sampled from a Gaussian distribution?</u>			
The paired t test assumes that the differences are sampled from a Gaussian distribution. This assumption is tested using the method of Kolmogorov and Smirnov:			
The Kolmogorov-Smirnov distance (KS) is 0.27			
The P value is 0.0434			
The data failed the normality test with P<0.05.			
Consider using a nonparametric test or transforming the data (i.e. converting to logarithms or reciprocals).			
Summary of Data			
Parameter:	Manual Heart RT	RFID Heart Rate	Difference
Mean:	115.35	95.320	20.030
# of points:	10	10	10
Std deviation:	15.583	14.319	3.486
Std error:	4.928	4.528	1.102
Minimum:	97.800	80.500	15.200
Maximum:	138.00	122.80	24.800
Median:	118.95	96.900	19.100
Lower 95% CI:	104.20	85.078	17.536
Upper 95% CI:	126.50	105.56	22.524

Figure 0.2 Significance test for heart rate results obtained

Paired t test			
Does the mean of the differences between Manual Energy E and RFID Energy Exp differ significantly from zero?			
<u>P value</u>			
The two-tailed P value is < 0.0001, considered extremely significant.			
t = 19.793 with 9 degrees of freedom.			
<u>95% confidence interval</u>			
Mean difference = 3.027 (Mean of paired differences)			
The 95% confidence interval of the difference: 2.681 to 3.373			
<u>Assumption test: Was the pairing effective?</u>			
Correlation coefficient (r) = 0.9526			
The one-tailed P value is < 0.0001, considered extremely significant.			
Effective pairing results in a significant correlation between the columns.			
With these data, the pairing (or matching) appears to be effective.			
<u>Assumption test: Are the differences sampled from a Gaussian distribution?</u>			
The paired t test assumes that the differences are sampled from a Gaussian distribution. This assumption is tested using the method of Kolmogorov and Smirnov:			
The Kolmogorov-Smirnov distance (KS) is 0.24			
The P value is >0.10The data passed the normality test with P>0.05.			
Summary of Data			
Parameter:	Manual Energy E	RFID Energy Exp	Difference
Mean:	9.257	6.230	3.027
# of points:	10	10	10
Std deviation:	1.283	0.9365	0.4836
Std error:	0.4057	0.2961	0.1529
Minimum:	7.950	5.260	2.230
Maximum:	11.220	8.030	3.630
Median:	9.060	6.330	2.955
Lower 95% CI:	8.339	5.560	2.681
Upper 95% CI:	10.175	6.900	3.373

Figure 0.3 Significance test for energy expenditure of the two systems

Paired t test			
Does the mean of the differences between Manual TCCW and RFID TCCW differ significantly from zero?			
<u>P value</u>			
The two-tailed P value is < 0.0001, considered extremely significant.			
t = 23.399 with 9 degrees of freedom.			
<u>95% confidence interval</u>			
Mean difference = 133.86 (Mean of paired differences)			
The 95% confidence interval of the difference: 120.92 to 146.80			
<u>Assumption test: Was the pairing effective?</u>			
Correlation coefficient (r) = 1.0000			
The one-tailed P value is < 0.0001, considered extremely significant.			
Effective pairing results in a significant correlation between the columns.			
With these data, the pairing (or matching) appears to be effective.			
<u>Assumption test: Are the differences sampled from a Gaussian distribution?</u>			
The paired t test assumes that the differences are sampled from a Gaussian distribution. This assumption is tested using the method of Kolmogorov and Smirnov:			
The Kolmogorov-Smirnov distance (KS) is 0.25			
The P value is 0.0810The data passed the normality test with P>0.05.			
Summary of Data			
Parameter:	Manual TCCW	RFID TCCW	Difference
Mean:	753.55	619.69	133.86
# of points:	10	10	10
Std deviation:	101.86	83.767	18.091
Std error:	32.210	26.489	5.721
Minimum:	638.74	525.27	113.47
Maximum:	901.39	741.27	160.12
Median:	777.03	639.00	138.03
Lower 95% CI:	680.69	559.77	120.92
Upper 95% CI:	826.41	679.61	146.80

Figure 0.4 Significance test for total cardiac cost of work of the two systems

Paired t test			
Does the mean of the differences between Manual PCW and RFID PCW differ significantly from zero?			
<u>P value</u>			
The two-tailed P value is < 0.0001, considered extremely significant.			
t = 23.429 with 9 degrees of freedom.			
<u>95% confidence interval</u>			
Mean difference = 4.190 (Mean of paired differences)			
The 95% confidence interval of the difference: 3.785 to 4.595			
<u>Assumption test: Was the pairing effective?</u>			
Correlation coefficient (r) = 1.0000			
The one-tailed P value is < 0.0001, considered extremely significant.			
Effective pairing results in a significant correlation between the columns.			
With these data, the pairing (or matching) appears to be effective.			
<u>Assumption test: Are the differences sampled from a Gaussian distribution?</u>			
The paired t test assumes that the differences are sampled from a Gaussian distribution. This assumption is tested using the method of Kolmogorov and Smirnov:			
The Kolmogorov-Smirnov distance (KS) is 0.25			
The P value is 0.0835The data passed the normality test with P>0.05.			
Summary of Data			
Parameter:	Manual PCW	RFID PCW	Difference
Mean:	18.340	14.150	4.190
# of points:	10	10	10
Std deviation:	2.479	1.913	0.5655
Std error:	0.7838	0.6050	0.1788
Minimum:	15.550	11.990	3.560
Maximum:	21.940	16.930	5.010
Median:	18.910	14.590	4.320
Lower 95% CI:	16.567	12.781	3.785
Upper 95% CI:	20.113	15.519	4.595

Figure 0.5 Significance test for physiological cost of work of the two systems

Paired t test			
Does the mean of the differences between Manual Breath f and RFID Breath fre differ significantly from zero?			
<u>P value</u>			
The two-tailed P value is < 0.0001, considered extremely significant.			
t = 13.099 with 9 degrees of freedom.			
<u>95% confidence interval</u>			
Mean difference = 1.540 (Mean of paired differences)			
The 95% confidence interval of the difference: 1.274 to 1.806			
<u>Assumption test: Was the pairing effective?</u>			
Correlation coefficient (r) = 0.9773			
The one-tailed P value is < 0.0001, considered extremely significant.			
Effective pairing results in a significant correlation between the columns.			
With these data, the pairing (or matching) appears to be effective.			
<u>Assumption test: Are the differences sampled from a Gaussian distribution?</u>			
The paired t test assumes that the differences are sampled from a Gaussian distribution. This assumption is tested using the method of Kolmogorov and Smirnov:			
The Kolmogorov-Smirnov distance (KS) is 0.16			
The P value is >0.10The data passed the normality test with P>0.05.			
Summary of Data			
<b>Parameter:</b>	<b>Manual Breath f</b>	<b>RFID Breath fre</b>	<b>Difference</b>
Mean:	12.940	11.400	1.540
# of points:	10	10	10
Std deviation:	1.754	1.720	0.3718
Std error:	0.5548	0.5441	0.1176
Minimum:	11.000	9.600	0.8000
Maximum:	15.500	14.700	2.000
Median:	13.350	11.600	1.500
Lower 95% CI:	11.685	10.169	1.274
Upper 95% CI:	14.195	12.631	1.806

Figure 0.6 Significance test for cattle breathing frequency for the two systems

Paired t test			
Does the mean of the differences between Manual Heart RT and RFID Heart RT differ significantly from zero?			
<u>P value</u>			
The two-tailed P value is < 0.0001, considered extremely significant.			
t = 12.542 with 9 degrees of freedom.			
<u>95% confidence interval</u>			
Mean difference = 11.080 (Mean of paired differences)			
The 95% confidence interval of the difference: 9.082 to 13.078			
<u>Assumption test: Was the pairing effective?</u>			
Correlation coefficient (r) = 0.9760			
The one-tailed P value is < 0.0001, considered extremely significant.			
Effective pairing results in a significant correlation between the columns.			
With these data, the pairing (or matching) appears to be effective.			
<u>Assumption test: Are the differences sampled from a Gaussian distribution?</u>			
The paired t test assumes that the differences are sampled from a Gaussian distribution. This assumption is tested using the method of Kolmogorov and Smirnov:			
The Kolmogorov-Smirnov distance (KS) is 0.20			
The P value is >0.10The data passed the normality test with P>0.05.			
Summary of Data			
<b>Parameter:</b>	<b>Manual Heart RT</b>	<b>RFID Heart RT</b>	<b>Difference</b>
Mean:	94.900	83.820	11.080
# of points:	10	10	10
Std deviation:	12.823	12.599	2.794
Std error:	4.055	3.984	0.8834
Minimum:	80.400	70.800	5.500
Maximum:	113.50	108.00	14.900
Median:	97.850	85.200	10.650
Lower 95% CI:	85.727	74.808	9.082
Upper 95% CI:	104.07	92.832	13.078

Figure 0.7 Significance test for cattle heart rate for the two systems