

*CLOSURE OPERATORS ON COMPLETE LATTICES*

*WITH*

*APPLICATION TO COMPACTNESS*

*by*

*DEONARAIN BRIJLALL*

*Submitted in partial fulfilment of the  
requirements for the degree of  
Master of Science  
in the  
Department of Mathematics and Applied Mathematics,  
University of Natal,  
Durban.*

Durban  
January 1995

## PREFACE

The work described in this thesis was carried out under the supervision of Professor Teo Sturm initially and subsequently under the supervision of Doctor Olav Jordens, Department of Mathematics and Applied Mathematics, University of Natal, Durban, from January 1993 to January 1995.

This thesis represents original work by the author and has not been submitted in any form to another University. Where use was made of the work of others it has been duly acknowledged in the text.

## ACKNOWLEDGEMENTS

I wish at the very outset to express my sincere thanks and appreciation to the following persons each of whom has made a valuable contribution to my mathematical education, and in particular, this thesis:

My supervisor, Doctor Olav Jordens for his guidance and enthusiastic encouragement during the past two years.

Professor Teo Sturm for financially supporting my studies for the past two years.

The Head of the Department of Mathematics and Applied Mathematics at the University of Natal, Durban, as well as the entire staff of the Department.

My wife Shubha, son Shiven and daughter Sheetal for sparing me their quality time.

My mum, dad, brother Saigal and sister-in-law Rumba for their financial and moral support especially during my undergraduate years of study.

## CONTENTS

### CHAPTER 0 ..... Page 1

This chapter reviews known results and preliminaries. It revolves around the basic theory of cofinality, ordinals and cardinality as described in set theory and introduces certain results from general lattice theory that are relevant to this thesis. Most of the results and terminology discussed in this chapter form part of mathematical folk-lore and will probably be well-known to the reader. However, in this case, the identification of the concepts and the notation to be used in the later chapters is eased.

### CHAPTER 1 ..... Page 6

This chapter introduces the concepts of closure operators and closure systems on complete lattices. For an infinite cardinal  $m$ ,  $m$ -algebraic closure operators are defined using  $m$ -directed sets. This leads to the consideration of  $m$ -accessible elements and  $m$ -accessible preserving closure operators. Those lattices for which every closure operator is  $m$ -algebraic are characterised. Also of significance in the study of  $m$ -algebraic closure operators are the weak  $m$ -compact elements of a complete lattice  $L$ . It is shown that every  $m$ -algebraic closure operator preserves weak  $m$ -compactness. Lattices for which every closure operator preserves weak  $m$ -compactness are characterised as well as those lattices for which every closure operator preserving weak  $m$ -compactness is  $m$ -algebraic. Finally weak  $m$ -algebraic lattices are introduced. On such lattices the concepts of  $m$ -algebraic closure operator, and weak  $m$ -compact preserving closure operator coincide and further such lattices may be characterised as complete lattices on which every closure operator is weak  $m$ -compact reflecting.

### CHAPTER 2 ..... Page 39

This chapter develops a slightly different generalisation of the well-known concept of compactness in complete lattices. For an infinite cardinal  $m$ ,  $m$ -compactness is defined and is shown to agree with weak  $m$ -compactness for regular  $m$ . Analogues of theorems developed in Chapter 1 are presented for the case of  $m$ -compactness. It is shown that only for regular  $m$  is an  $m$ -algebraic closure operator always  $m$ -compact preserving. Weak  $m$ -accessible elements of a closure operator are introduced in order to characterise the  $m$ -compact preserving closure operators. Corresponding to the concept of weak  $m$ -algebraic lattices in Chapter 1, the concept of  $m$ -algebraic lattices is defined. These lattices are characterised in terms of  $m$ -compact reflecting closure operator only for regular  $m$ .

CHAPTER 3 ..... Page 65

In Chapter 1 the significance of weak  $m$ -algebraic lattices in the study of closure operators is shown. Weak  $m$ -algebraic lattices may be characterised as those lattices for which every closure operator is weak  $m$ -compact reflecting. On a weak  $m$ -algebraic lattice the concepts of  $m$ -algebraic closure operator and weak  $m$ -compact preserving closure operator coincide. This does not however characterise weak  $m$ -algebraic lattices. This chapter explores weak  $m$ -Tulipani closure operators. It is shown that these operators are weak  $m$ -compact preserving and that weak  $m$ -algebraic lattices are precisely those complete lattices on which the weak  $m$ -Tulipani and  $m$ -algebraic closure operators coincide.

CHAPTER 4 ..... Page 78

For a non-empty set  $M$  and a closure system  $S$ ,  $E(M)$  denotes the complete lattice of all equivalences on  $M$ . To every closure system  $S$  on  $\exp M$  there corresponds a closure system  $e(S)$  on  $E(M)$ . If  $S$  is  $m$ -algebraic so is  $e(S)$ . Closure systems of the form  $e(S)$  are characterised, and a recursive construction of the closure operator corresponding to  $e(S)$  is given. Conditions on  $S$  which are necessary and sufficient for  $e(S)$  to be a subcomplete lattice of  $E(M)$  are presented. For regular  $m$  the  $m$ -compact elements of  $e(S)$ , where  $S$  is  $m$ -algebraic, are characterised in some situations. In fact this is done in a more general setting.

NOTES ON REFERENCES ..... Page 102

REFERENCES ..... Page 104

INDEX ..... Page 107

## CHAPTER 0

This chapter reviews known results and preliminaries. It revolves around the basic theory of cofinality, ordinals and cardinality as described in set theory and introduces certain results from general lattice theory that are relevant to this thesis. Most of the results and terminology discussed in this chapter form part of mathematical folk-lore and will probably be well-known to the reader. However, in this case, the identification of the concepts and the notation to be used in the later chapters is eased.

### DEFINITION 0.1.

Let  $r$  and  $s$  be binary relations on a nonempty set  $M$ . The *relational product* of  $r$  and  $s$  is defined as

$$r \circ s = \{\langle x, y \rangle; \text{there exists } z \text{ with } xrz \text{ and } zsy\}.$$

Note that this notation clashes with functional composition which is written in reverse order, but this notation is widely used and so no confusion will result.

### REMARK 0.2.

Of particular importance are the equivalence relations which are reflexive, symmetric and transitive binary relations. These relations will generally be denoted by  $\sigma$  or  $\tau$ . We shall denote the set of all equivalences on a set  $M$  by  $E(M)$ . Further it is noted that  $E(M)$  is naturally ordered by inclusion.

### DEFINITION 0.3.

If  $\sigma$  is an equivalence relation on a nonempty set  $M$ , and if  $x \in M$ , then the *equivalence class of  $x$  modulo  $\sigma$*  is defined as

$$x/\sigma = \{y \in M; x\sigma y\}.$$

Further, the *quotient set of  $M$  modulo  $\sigma$*  is defined as

$$M/\sigma = \{x/\sigma; x \in M\}.$$

Elements of  $M/\sigma$  are also known as the *blocks* of  $M$  modulo  $\sigma$ . There exists a natural one-to-one correspondence between equivalence relations on a nonempty set and partitions of the set. The *identity relation* on a set  $M$  is:

$$id_M = \{\langle x, x \rangle; x \in M\}.$$

For an equivalence relation  $\sigma$  on nonempty set  $M$ , the *natural projection* map  $n_\sigma : M \rightarrow M/\sigma$  is defined in the usual way by  $n_\sigma(x) = x/\sigma$  for all  $x \in M$ .

#### DEFINITION 0.4.

Let  $\rho$  be a binary relation on a set  $P$ . Then  $\rho$  is called a *partial ordering (relation)* if it is reflexive, antisymmetric and transitive.

#### REMARK 0.5.

The set  $P$  together with the partial ordering  $\rho$  is called a (*partially*) *ordered set* denoted by  $\langle P; \rho \rangle$  or sometimes by the symbol  $P$  if the ordering  $\rho$  is understood. The set theory used is the usual Zermelo-Fraenkel set theory with the Axiom of Choice. Our concept of ordinals and cardinals follows that of von Neumann where an ordinal is the set of all preceding ordinals, and an ordinal is well-ordered by the element relation  $\in$ , which on an ordinal is also the proper inclusion relation  $\subset$ . A cardinal is an initial ordinal. Ordinals will generally be denoted by the greek letters  $\zeta$ ,  $\eta$  and  $\xi$ , and cardinals will generally be denoted by  $m$ ,  $n$  and  $k$ . We use  $\omega$  to denote the least infinite cardinal. The ordinal successor of ordinal  $\xi$  is written  $\xi \oplus 1$  and the cardinal successor of cardinal  $m$  is written  $m^+$ . The cardinality of a set  $M$  is denoted by  $|M|$ . Elementary remarks of cardinal arithmetic are assumed known (see [11]). We shall denote the set of all subsets of a set  $M$  by  $\exp M$ .

DEFINITION 0.6.

Let  $P$  be a partially ordered set. A subset  $A \subseteq P$  is called an *order ideal* of  $P$  if  $A$  satisfies:

$$x \in A \text{ and } y \leq x \text{ implies } y \in A.$$

$A$  is sometimes termed as a *hereditary* subset of  $P$ . Dually we define an *order filter* of  $P$ .

For an element  $x \in P$ , the *principal ideal in  $P$  generated by  $x$*  is

$$(x]_P = \{y \in P; y \leq x\}.$$

If no confusion can result  $(x]_P$  will be denoted  $(x]$ . Dually, we define the symbol  $[x)_P$ , to denote the *principal filter generated by  $x$* .

DEFINITION 0.7.

If  $\langle P, \leq \rangle$  is a partially ordered set and  $X \subseteq P$ , we say that  $X$  is *cofinal* in  $P$  if for all  $p \in P$  there exists  $x \in X$  such that  $p \leq x$ .

DEFINITION 0.8.

The *cofinality* of a partially ordered set  $\langle P, \leq \rangle$  is the least cardinal  $m$  such that  $P$  has a cofinal subset  $X$  with  $|X| = m$ .

We shall denote the cofinality of a partially ordered set  $P$  by  $cf(P)$  throughout the text.

DEFINITION 0.9.

An infinite cardinal  $m$  is said to be a *regular* cardinal if  $cf(m) = m$ . If an infinite cardinal is not regular we shall call it a *singular* cardinal. For singular cardinals  $cf(m) < m$ . It is well known that an infinite cardinal  $m$  is *regular* if and only if



for any set  $\{m_i; i \in I\}$  of cardinals such that  $|I| < m$  and  $m_i < m$  for all  $i \in I$ , we have that  $\sum_{i \in I} m_i < m$ . Further for any infinite cardinal  $m$ , the cardinal successor  $m^+$  is always a regular cardinal.

DEFINITION 0.10.

A partially ordered set  $\langle P, \rho \rangle$  is called a *chain* if for all  $a, b \in P$  we have  $a \leq b$  or  $b \leq a$ .

REMARK 0.11.

If  $\langle P, \rho \rangle$  is a partially ordered set and  $a, b \in P$ , then  $a$  and  $b$  are *comparable* if  $a \leq b$  or  $b \leq a$ . Otherwise,  $a$  and  $b$  are *incomparable* and this is indicated by  $a \parallel b$ . A chain is, therefore, a partially ordered set in which there are no incomparable elements. Also we shall make use of the *cover relation* denoted by  $b \prec a$  read as  $a$  covers  $b$  or  $b$  is covered by  $a$  iff  $a \leq b$  and for any  $x \in P$ ,  $a \leq x \leq b$  implies  $x = a$  or  $x = b$ .

If  $P$  has a least element  $0_P$ , then  $x \in P$  is an *atom* of  $P$  if  $0_P \prec x$ . We will generally denote the least element of  $P$  by  $0_P$  and the greatest element of  $P$  by  $1_P$  if they exist.

DEFINITION 0.12.

Let  $X \subseteq \langle P, \rho \rangle$  and  $a \in P$ . Then  $a$  is defined to be an *upper bound* of  $X$  if  $x \leq a$  for all  $x \in X$ . An upper bound  $a$  of  $X$  is called *the least upper bound* or *supremum* of  $X$  iff, for any upper bound  $b$  of  $X$ , we have  $a \leq b$ . We shall, throughout this thesis, denote the supremum of a set  $X$  by  $\bigvee_P X$ , or  $\bigvee X$  if no confusion results. We shall also come across the dually defined *greatest lower bound* of a set  $Y$  which will be denoted by  $\bigwedge_P Y$ .

REMARK 0.13.

We shall make use of the following result, the proof of which, appears in [2,p.16]:  
 Let  $M$  be a nonempty set,  $\Sigma \subseteq E(M)$  and  $x, y \in M$ . Then  $\langle x, y \rangle \in \bigvee_{E(M)} \Sigma$  if and only if there exists a finite  $\Sigma_0 \subseteq \Sigma$  such that  $\langle x, y \rangle \in \bigvee_{E(M)} \Sigma_0$ .

DEFINITION 0.14.

A partially ordered set  $\langle L, \leq \rangle$  is called a *lattice* if for all  $a, b \in L$ ,  $\bigvee_L \{a, b\}$  and  $\bigwedge_L \{a, b\}$  exist in  $L$ .

A lattice  $\langle L, \leq \rangle$  is said to be *complete* if  $\bigvee_L X$  exists in  $L$  for all  $X \subseteq L$ . We shall henceforth, without the loss of generality, denote a complete lattice  $\langle L, \leq \rangle$  by  $L$ .

We shall make use of the following result for a lattice  $L$  (see [1] or [5]):

$$\begin{aligned}
 L \text{ is a complete lattice} &\Leftrightarrow \text{for every } X \subseteq L, \bigvee_L X \in L \\
 &\Leftrightarrow \text{for every } X \subseteq L, \bigwedge_L X \in L \\
 &\Leftrightarrow \text{for every } X \subseteq L, \bigvee_L X \in L \text{ and } \bigwedge_L X \in L.
 \end{aligned}$$

## CHAPTER 1

This chapter introduces the concepts of closure operators and closure systems on complete lattices. For an infinite cardinal  $m$ ,  $m$ -algebraic closure operators are defined using  $m$ -directed sets. This leads to the consideration of  $m$ -accessible elements and  $m$ -accessible preserving closure operators. Those lattices for which every closure operator is  $m$ -algebraic are characterised. Also of significance in the study of  $m$ -algebraic closure operators are the weak  $m$ -compact elements of a complete lattice  $L$ . It is shown that every  $m$ -algebraic closure operator preserves weak  $m$ -compactness. Lattices for which every closure operator preserves weak  $m$ -compactness are characterised as well as those lattices for which every closure operator preserving weak  $m$ -compactness is  $m$ -algebraic. Finally weak  $m$ -algebraic lattices are introduced. On such lattices the concepts of  $m$ -algebraic closure operator, and weak  $m$ -compact preserving closure operator coincide and further such lattices may be characterised as complete lattices on which every closure operator is weak  $m$ -compact reflecting.

### DEFINITION 1.1.

Let  $L$  be a complete lattice.

(a) A mapping  $u : L \rightarrow L$  is a *closure operator* on  $L$  if  $u$  satisfies:

- i. For all  $x \in L$ ,  $x \leq u(x) = u(u(x))$ , and
- ii. For all  $x, y \in L$ ,  $x \leq y$  implies  $u(x) \leq u(y)$ .

(b) A subset  $S \subseteq L$  is called a *closure system* on  $L$  if  $S$  satisfies:

For every  $X \subseteq S$ ,  $\bigwedge_L X \in S$ , also.

LEMMA 1.2.

Let  $L$  be a complete lattice. A mapping  $u : L \rightarrow L$  is a closure operator on  $L$  if and only if  $u$  satisfies:

- i. For all  $x \in L$ ,  $x \leq u(x) = u(u(x))$ , and
- ii. For every  $X \subseteq L$ ,  $u(\bigvee_L X) = \bigvee_{u[L]} u[X]$ , where  $u[L]$  is a subposet of  $\langle L; \leq \rangle$ .

PROOF

( $\Rightarrow$ ): If  $u$  is a closure operator then the first condition holds by Definition 1.1. For the second condition, we have for every  $x \in X$ ,  $u(x) \leq u(\bigvee_L X)$  and so  $u(\bigvee_L X) \in u[L]$  is an upper bound of  $u[X]$  in  $u[L]$ . Let for some  $y \in L$ ,  $u(y)$  be an upper bound of  $u[X]$ . Then  $u(y)$  is also an upper bound of  $X$ , since for every  $x \in X$ ,  $x \leq u(x) \leq u(y)$ . Therefore,  $\bigvee_L X \leq u(y)$ , which implies  $u(\bigvee_L X) \leq u(u(y)) = u(y)$ . Hence,  $u(\bigvee_L X)$  is the least upper bound of  $u[X]$  in  $u[L]$ .

( $\Leftarrow$ ): The first condition of Definition 1.1 is satisfied. For the second condition of this definition, let  $x, y \in L$  and suppose that  $x \leq y$ . By condition (ii), letting  $X = \{x, y\}$  we have  $\bigvee_L X = y$  and so  $u(\bigvee_L X) = u(y)$ . Hence  $\bigvee_{u[L]} u[X] = \bigvee_{u[L]} \{u(x), u(y)\}$  which implies that  $u(x) \leq u(y)$ .

LEMMA 1.3

Let  $L$  be a complete lattice. Let  $S$  be a closure system on  $L$ . Then  $\langle S; \leq_L \rangle$  is a complete lattice satisfying for each  $X \subseteq S$ ,  $\bigwedge_S X = \bigwedge_L X$ .

PROOF

Firstly,  $\langle S; \leq_L \rangle$  is an ordered set. We shall show that if  $X \subseteq S$  then  $\bigwedge_L X = \bigwedge_S X$ . As  $S$  is a closure system on  $L$ ,  $\bigwedge_L X \in S$  and  $\bigwedge_L X$  is evidently a lower bound of

$X$ . Now let  $y \in S$  be any lower bound of  $X$ . Then for each  $x \in X$ ,  $y \leq_L x$  and thus  $y \leq \bigwedge_L X$ . Consequently,  $\bigwedge_L X = \bigwedge_S X$  and  $\langle S, \leq_L \rangle$  is a complete lattice.

LEMMA 1.4.

Let  $L$  be a complete lattice and let  $u : L \rightarrow L$  be a closure operator on  $L$ . Then  $u[L]$  is a closure system on  $L$ . Further, given any closure system  $S$  on  $L$  define  $u_S : L \rightarrow L$  by setting:

$$u_S(x) = \bigwedge_L \{y \in S; x \leq y\}.$$

Then  $u_S$  is a closure operator on  $L$ , and  $u_S[L] = S$ . Also, if  $S = u[L]$ , then  $u_S = u$ .

PROOF

To show that  $u[L]$  is a closure system on  $L$  we shall show that for every  $X \subseteq u[L]$ ,  $\bigwedge_L X \in u[L]$ . Now for all  $x \in X$ ,  $\bigwedge_L X \leq x$  and so  $u(\bigwedge_L X) \leq u(x) = x$  which in turn implies that  $u(\bigwedge_L X) \leq \bigwedge_L X$ . But  $\bigwedge_L X \leq u(\bigwedge_L X)$ , obviously. Therefore,  $u(\bigwedge_L X) = \bigwedge_L X \in u[L]$ .

To show that  $u_s$  is a closure operator, take  $x \in L$ . Evidently  $x \leq u_s(x)$ . Notice from the definition of a closure system and of  $u_s$  we have that for all  $x \in L$ ,  $u_s(x) \in S$ . Now  $u_s(u_s(x)) = \bigwedge_L \{y \in S; u_s(x) \leq y\} = u_s(x)$ . So we have shown  $x \leq u_s(x) = u_s(u_s(x))$ . Finally let  $x \leq z$ . Then  $\{y \in S; z \leq y\} \subseteq \{y \in S; x \leq y\}$ . Therefore  $\bigwedge_L \{y \in S; x \leq y\} \leq \bigwedge_L \{y \in S; z \leq y\}$  and hence  $u_s(x) \leq u_s(z)$ .

Now to show that  $u_s[L] = S$ . We have already noticed that for all  $x \in L$ ,  $u_s(x) \in S$ . Therefore  $u_s[L] \subseteq S$ . Conversely if  $x \in S$  we show that  $x \in u_s[L]$ . In fact  $u_s(x) = \bigwedge_L \{y \in S; x \leq y\} = x$ . Therefore  $x = u_s(x) \in u_s[L]$  and hence  $u_s[L] = S$ .

Suppose that  $S = u[L]$ . We show that  $u_s = u$ . First  $u_s(x) = \bigwedge_L \{y \in u[L]; x \leq y\}$ . As  $x \leq u(x) \in u[L]$  it follows that  $u_s(x) \leq u(x)$ . Conversely: If  $y \in u[L]$  and  $x \leq y$  then  $u(x) \leq u(y) = y$ . Therefore  $u(x)$  is a lower bound of  $\{y \in u[L]; x \leq y\}$ ,

and hence  $u(x) \leq u_s(x)$ .

REMARK 1.5.

It follows from Lemmas 1.2, 1.3 and 1.4 above that a closure operator  $u : L \rightarrow L$  satisfies for  $X \subseteq L$ :

- i.  $u(\bigvee_L X) = \bigvee_{u[L]} u[X]$ , and
- ii.  $\bigwedge_L u[X] = \bigwedge_{u[L]} u[X]$ .

This gives an explicit description of the supremum and infimum operators on the complete lattice  $\langle u[L], \leq_L \rangle$ . Notice that  $\bigwedge_L = \bigwedge_{u[L]}$  but in general  $\bigvee_L \neq \bigvee_{u[L]}$ . In fact for  $X \subseteq L$ ,  $\bigvee_L u[X] \leq \bigvee_{u[L]} u[X]$ . The behaviour of  $\bigvee_{u[L]}$  depends not only on  $\bigvee_L$  but also on the closure operator  $u$ . We say that  $S \subseteq L$  is a *sub-complete lattice* of  $L$  if for every  $X \subseteq S$ ,  $\bigwedge_L X \in S$  and  $\bigvee_L X \in S$ . It is readily verified that closure operator  $u : L \rightarrow L$  satisfies  $\bigvee_L u[X] = \bigvee_{u[L]} u[X]$  for each  $X \subseteq L$  if and only if  $u[L]$  is a sub-complete lattice of  $L$ . A natural example arises: Let  $\langle A, \leq_A \rangle$  be an ordered set and define  $u : \exp A \rightarrow \exp A$  by setting

$$u(B) = \{x \in A; \text{there exists } y \in B \text{ and } x \leq y\}, \text{ for each } B \subseteq A.$$

Perhaps the most important examples of closure operators and closure systems in universal algebra arise when considering subalgebras and congruences. The lattice of subalgebras of a universal algebra is a closure system on the lattice of all subsets of the algebra. The lattice of congruences on an algebra is a closure system on the lattice of all equivalence relations on the algebra. For these two cases we have that  $\bigvee_L u[X] = \bigvee_{u[L]} u[X]$  whenever  $X$  is a directed subset of  $L$ . We explore this further:

DEFINITION 1.6.

Let  $\langle X, \leq \rangle$  be a non-empty ordered set and  $m$  an infinite cardinal. Then  $X$  is

$m$ -directed, if for every  $Y \subseteq X$  with  $|Y| < m$ , there exists  $x \in X$  such that for all  $y \in Y$ ,  $y \leq x$ .

An  $\omega$ -directed set is referred to merely as *directed*.

Generally we consider subsets of a complete lattice  $L$  which are  $m$ -directed under the ordering of  $L$ .

**LEMMA 1.7.**

Let  $m$  be a regular infinite cardinal and  $\emptyset \neq X \subseteq L$ . Then

$$X^* = \left\{ \bigvee_L Y; Y \subseteq X \text{ and } |Y| < m \right\}$$

is  $m$ -directed and  $\bigvee_L X = \bigvee_L X^*$ .

**PROOF**

Take any subset  $T$  of  $X^*$  with cardinality strictly smaller than  $m$ . For every  $t \in T$  there exists  $Y_t \subseteq X$  such that  $|Y_t| < m$  and  $\bigvee_L Y_t = t \in X$ . Let  $Z = \bigcup \{Y_t; t \in T\}$ . Since  $m$  is regular,  $|Z| < m$ , which yields  $\bigvee_L Z \in X^*$ . Hence, as  $\bigvee_L Z$  is an upper bound of  $T$ ,  $X^*$  is  $m$ -directed.

Now we show that  $\bigvee_L X^* = \bigvee_L X$ . Trivially  $X \subseteq X^*$ . Therefore  $\bigvee_L X \leq \bigvee_L X^*$ . Conversely, take  $z \in X^*$ . Then  $z = \bigvee_L Y$ , for some  $Y \subseteq X$  with  $|Y| < m$ . This implies that  $z \leq \bigvee_L X$ . Therefore  $\bigvee_L X$  is an upper bound of  $X^*$  and hence  $\bigvee_L X^* \leq \bigvee_L X$ .

**DEFINITION 1.8.**

We shall frequently make use of  $\bar{m}$  to denote the least regular cardinal  $\geq m$ :

$$\bar{m} = \begin{cases} m & \text{if } m \text{ is regular} \\ m^+ & \text{if } m \text{ is singular} \end{cases}$$

LEMMA 1.9.

Let  $L$  be a complete lattice and  $m$  and  $n$  infinite cardinals. The following results hold:

- i. If  $m \leq n$  then for every  $X \subseteq L$ ,  $X$  is  $n$ -directed only if  $X$  is  $m$ -directed.
- ii. For every  $X \subseteq L$ ,  $X$  is  $m$ -directed if and only if  $X$  is  $\bar{m}$ -directed.
- iii. For every  $X \subseteq L$ ,  $X$  is directed if and only if for each  $x, y \in X$ , there exists  $z \in X$  such that  $x \leq z$  and  $y \leq z$ .

PROOF

The proofs of (i) and (iii) are evident. For (ii), assume without loss of generality, that  $m$  is singular. If  $X$  is  $\bar{m}$ -directed, it is of course,  $m$ -directed too. Let us suppose that  $X$  is  $m$ -directed and  $Y \subseteq X$  with  $|Y| < \bar{m} = m^+$ . Hence,  $|Y| \leq m$ . We show that  $Y$  has an upper bound in  $X$ . If  $|Y| < m$ , we are done. So, suppose that  $|Y| = m$ . Then there exists a family  $\{Y_i; i \in I\}$  of subsets of  $Y$  such that  $|I| < m$ ,  $Y = \bigcup_{i \in I} Y_i$  and for every  $i \in I$ ,  $|Y_i| = m_i < m$ . Since  $X$  is  $m$ -directed, we can choose, for each  $i \in I$ , an element  $x_i \in X$  such that  $x_i$  is an upper bound of  $Y_i$ . Denote by  $Z$  the set of all such  $x_i$ . Then  $|Z| \leq |I| < m$ . Thus  $Z$  has an upper bound  $x \in X$ . But then,  $x$  is evidently an upper bound of  $Y$ .

COROLLARY 1.10.

Let  $m$  be an infinite cardinal and  $X \subseteq L$ . Then

$$X^* = \{\bigvee_L Y; Y \subseteq X \text{ and } |Y| < \bar{m}\}$$

is  $m$ -directed and  $\bigvee_L X = \bigvee_L X^*$ .



PROOF

The proof follows from Definition 1.8, and Lemmas 1.7 and 1.9.

LEMMA 1.11.

Let  $u : L \rightarrow L$  be a closure operator. Then the following conditions are equivalent:

- i. For every  $X \subseteq u[L]$ , where  $X$  is  $m$ -directed,  $u(\bigvee_L X) = \bigvee_L X$ .
- ii. For every  $X \subseteq u[L]$ , where  $X$  is  $m$ -directed,  $\bigvee_L X = \bigvee_{u[L]} X$ .
- iii. For every  $X \subseteq L$ , where  $X$  is  $m$ -directed,  $u(\bigvee_L X) = \bigvee_L u[X]$ .
- iv. For every  $X \subseteq L$ , where  $X$  is  $m$ -directed,  $\bigvee_L u[X] = \bigvee_{u[L]} u[X]$ .

PROOF

Notice for  $X \subseteq u[L]$ ,  $u[X] = X$ . So,

$$\begin{aligned} u\left(\bigvee_L X\right) &= \bigvee_{u[L]} u[X] && \text{(by Lemma 1.2(ii))} \\ &= \bigvee_{u[L]} X. \end{aligned}$$

This proves that (i) and (ii) are equivalent.

Also, Lemma 1.2(ii) guarantees that (iii) and (iv) are equivalent.

We show that (i) implies (iv). Take  $X \subseteq L$ ,  $X$   $m$ -directed. This implies that  $u[X]$  is also  $m$ -directed. Hence we have:

$$\begin{aligned} \bigvee_L u[X] &= u\left(\bigvee_L u[X]\right) && \text{(since the first condition holds)} \\ &= \bigvee_{u[L]} u(u[X]) && \text{(by Lemma 1.2(ii))} \\ &= \bigvee_{u[L]} u[X]. \end{aligned}$$

Thus the fourth condition holds.

Finally we show that (iii) implies (i). Take  $X \subseteq u[L]$  where  $X$   $m$ -directed. Then we have:

$$\begin{aligned} u(\bigvee_L X) &= \bigvee_L u[X] && \text{(since the third condition holds)} \\ &= \bigvee_L X. && \text{(since } u[X] = X \text{)} \end{aligned}$$

So the third condition is true.

DEFINITION 1.12.

Let  $u : L \rightarrow L$  be a closure operator. Then  $u$  is an  $m$ -algebraic closure operator if  $u$  satisfies one (and hence all) of the conditions of Lemma 1.11.

A closure system  $S \subseteq L$  is an  $m$ -algebraic closure system if for every  $\emptyset \neq X \subseteq S$ ,  $X$   $m$ -directed, we have that  $\bigvee_S X = \bigvee_L X$ .

REMARK 1.13.

It follows immediately from Lemma 1.11(ii) that a closure operator  $u : L \rightarrow L$  is  $m$ -algebraic if and only if  $u[L]$  is an  $m$ -algebraic closure system on  $L$ .

COROLLARY 1.14.

- i. Let  $m \leq n$ . Then  $u : L \rightarrow L$  is an  $m$ -algebraic closure operator only if  $u : L \rightarrow L$  is an  $n$ -algebraic closure operator.*
- ii. Let  $u : L \rightarrow L$  be a closure operator. Then  $u$  is an  $m$ -algebraic closure operator on  $L$  if and only if  $u$  is an  $\bar{m}$ -algebraic closure operator on  $L$ .*

PROOF

This follows easily from Lemma 1.9 and Definition 1.12.

REMARK 1.15.

Let us return to the third condition in Lemma 1.11. In order to decide on the  $m$ -algebraicity of the closure operator  $u : L \rightarrow L$  we need to check that every  $m$ -directed subset  $X \subseteq L$  satisfies  $u(\bigvee_L X) = \bigvee_L u[X]$ . Notice that any closure operator has the following property:

*Let  $X \subseteq L$  and  $X$   $m$ -directed. Suppose that one of the following conditions holds:*

- i.  $\bigvee_L X = 1_L$ ,*
- ii.  $\bigvee_L X \in X$ .*

*Then  $u(\bigvee_L X) = \bigvee_L u[X]$ .*

Proof:

- i.  $\bigvee_L X \leq \bigvee_L u[X]$ . Therefore,  $\bigvee_L X = 1_L$  implies  $\bigvee_L u[X] = 1_L$ . Also it is clear that  $u(1_L) = 1_L$ .*
- ii.  $\bigvee_L X \in X$  if and only if  $\bigvee_L X$  is the maximum element of  $X$ . Moreover, if  $X$  has a maximum element  $\bigvee_L X$ , then  $u[X]$  also has a maximum element  $u(\bigvee_L X)$ . Hence  $\bigvee_L u[X] = u(\bigvee_L X)$  as required.*

So to determine whether or not  $u$  is  $m$ -algebraic, we need to consider those elements  $x \in L$  for which there exists  $\emptyset \neq X \subseteq L$ ,  $X$   $m$ -directed and  $x = \bigvee_L X \notin X$ , and show that in this case  $u(x) = \bigvee_L u[X]$ . Hence the following natural definition:

DEFINITION 1.16.

Let  $L$  be a complete lattice and  $A \subseteq L$ . An element  $x \in L$  is  *$m$ -accessible (in  $L$ ) via  $A$* , if there exists an  $m$ -directed  $X \subseteq A$  with  $x = \bigvee_L X \notin X$ .

If  $x \in L$  is  $m$ -accessible in  $L$  via  $L$  then we merely say that that  $x$  is  $m$ -accessible (in  $L$ ). An element  $x \in L$  is  $m$ -inaccessible (in  $L$ ) if  $x$  is not  $m$ -accessible (in  $L$ ).

COROLLARY 1.17.

- i. Let  $m \leq n$  and  $A \subseteq L$ . If  $x \in L$  is  $n$ -accessible in  $L$  via  $A$  then  $x$  is  $m$ -accessible in  $L$  via  $A$ .
- ii. Let  $x \in A \subseteq L$ . Then  $x$  is  $m$ -accessible in  $L$  via  $A$  iff  $x$  is  $\bar{m}$ -accessible in  $L$  via  $A$ .

PROOF

This follows easily from Lemma 1.9 and Definition 1.16.

REMARK 1.18.

a) Let  $u : L \rightarrow L$  be a closure operator. To highlight the difference between the concepts of  $m$ -accessibility in  $L$  via  $u[L]$  and  $m$ -accessibility in the complete lattice  $u[L]$ , we have:

*For each  $x \in L$ ,  $x$  is  $m$ -accessible in  $L$  via  $u[L]$  only if  $u(x)$  is  $m$ -accessible in  $u[L]$ .*

(Proof: Suppose that  $x$  is  $m$ -accessible in  $L$  via  $u[L]$ . Then  $x = \bigvee_L X$ , where  $X \subseteq u[L]$  is  $m$ -directed. But then,  $u(\bigvee_L X) = u(x)$  and  $u(\bigvee_L X) = \bigvee_{u[L]} X$  by Lemma 1.2(ii), and so  $u(x) = \bigvee_{u[L]} X$ , which implies that  $u(x)$  is  $m$ -accessible in  $u[L]$ .)

The converse, however, does not hold for consider the diagram that follows. The

shaded circles<sup>1</sup> in the diagram represent elements of  $u[L]$ . The set  $X$  is order isomorphic to the cardinal  $\bar{m}$ . Now  $u(x)$  is  $m$ -accessible in  $u[L]$ , as  $u(x) = \bigvee_{u[L]} X$ ,  $X$   $m$ -directed,  $X \subseteq L$ . But  $u(x) \neq \bigvee_L Y$  for any subset  $Y \subseteq u[L] \setminus \{u(x)\}$ .

So  $u(x)$  is not  $m$ -accessible in  $L$  via  $u[L]$ .

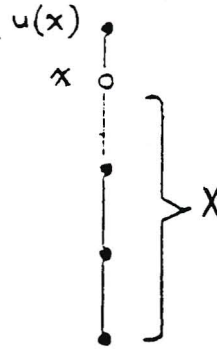

DIAGRAM 1.1.

b) If  $X \subseteq L$  is  $m$ -directed then  $\bigvee_L X \notin X$  holds if and only if  $X$  has no maximum element. There is no guarantee that  $u[X]$  will have no maximum element. We have the following counterexample:

**EXAMPLE 1.19.**

*For every cardinal  $m$  there exists a complete lattice  $L$  with  $|L| = \bar{m}$ , an  $m$ -algebraic closure operator  $u : L \rightarrow L$  and an  $m$ -accessible element  $x \in L$  with  $u(x)$  not  $m$ -accessible in  $L$  or  $u[L]$ .*

Consider the ordinal  $L = \bar{m} \oplus 2$  (see diagram below). Define  $u : L \rightarrow L$  by setting:

$$u(x) = \bar{m} \oplus 1, \text{ for each } x \in L.$$

<sup>1</sup>Shaded circles in a diagram of a complete lattice will always be used to represent elements of  $u[L]$ .

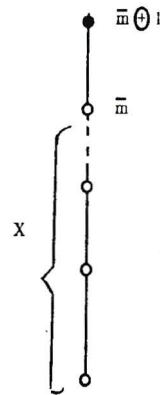

DIAGRAM 1.2.

Then  $u$  is  $m$ -algebraic,  $\bar{m}$  is  $m$ -accessible in  $L$  as  $\bar{m}$  is evidently an  $m$ -directed subset of  $L$ . However  $u(\bar{m}) = \bar{m} \oplus 1$  is not  $m$ -accessible in  $L$  for  $u[L] = \{\bar{m} \oplus 1\}$ .

We also have:

EXAMPLE 1.20.

*For every cardinal  $m$  there exists a complete lattice  $L$  with  $|L| = m$ , a closure operator  $u : L \rightarrow L$  satisfying: for every  $x \in L$ ,  $x$  is  $m$ -accessible in  $L$  only if  $u(x)$  is  $m$ -accessible in  $u[L]$ , but the closure operator  $u$  is not  $m$ -algebraic.*

If we consider  $L$  of Diagram 1.1 (Remark 1.18(a)), then  $x$  is the only  $m$ -accessible element of  $L$  and  $u(x) = 1_L$  is  $m$ -accessible in  $u[L]$ . But  $u$  is not  $m$ -algebraic as  $u(\bigvee_L X) = u(x) \neq \bigvee_L u[X] = \bigvee_L X = x$ .

REMARK 1.21.

Going back to Remark 1.15, to determine whether or not a closure operator is  $m$ -algebraic we need to consider the  $m$ -accessible elements of  $L$ . The following theorem is therefore not surprising:

THEOREM 1.22.

*Let  $L$  be a complete lattice and  $m$  an infinite cardinal. The following conditions*

are equivalent

- i. Every closure operator on  $L$  is an  $m$ -algebraic closure operator.
- ii. For every  $x \in L \setminus \{1_L\}$ ,  $x$  is  $m$ -inaccessible in  $L$ .

### PROOF

Suppose (i) holds and to the contrary assume that  $x < 1_L$  is  $m$ -accessible in  $L$ . Hence there exists  $\emptyset \neq X \subseteq L$ ,  $X$   $m$ -directed such that  $x = \bigvee_L X \notin X$ . Define  $u : L \rightarrow L$  as follows:

$$u(z) = \begin{cases} z, & \text{if } z < x \\ 1_L, & \text{otherwise} \end{cases}$$

We claim that  $u$  is an  $m$ -algebraic closure operator. Evidently  $z \leq u(z) = u(u(z))$ . Also for  $z_1 \leq z_2$  we have  $z_2 \leq x$  or  $z_2 \not\leq x$ . In the first case  $z_1 \leq x$  also. Therefore  $u(z_1) = u(z_2)$ . In the second case  $u(z_2) = 1_L$  and hence  $u(z_1) \leq u(z_2)$ . But  $u(\bigvee_L X) \neq \bigvee_L u[X]$  and so  $u$  is not  $m$ -algebraic by Lemma 1.11(iii).

( $\Leftarrow$ ): Let  $u : L \rightarrow L$  be a closure operator. We use the third condition of Lemma 1.11 to show that  $u$  is  $m$ -algebraic. Let  $\emptyset \neq X \subseteq L$  with  $X$   $m$ -directed.

Case 1: Suppose that  $\bigvee_L X \notin X$ . In this case  $\bigvee_L X$  is  $m$ -accessible and the only possibility then is  $\bigvee_L X = 1_L$ . But any closure operator satisfies  $\bigvee_L X \leq \bigvee_L u[X]$ . So we conclude that  $\bigvee_L u[X] = 1_L$ . Also  $u(1_L) = 1_L$  for any closure operator and so  $u(\bigvee_L X) = \bigvee_L u[X]$ .

Case 2: Suppose that  $\bigvee_L X \in X$ . Then  $\bigvee_L X$  is the maximum element of  $X$ . Therefore,  $u(\bigvee_L X)$  is the maximum element of  $u[X]$  and so  $u(\bigvee_L X) = \bigvee_L u[X]$ .

### THEOREM 1.23.

Let  $L$  be a complete lattice and  $A \subseteq L$ . The following conditions are equivalent:

- i. Every closure operator  $u$  on  $L$  satisfies ( $x \in A$  implies  $u(x) \in A$ ).

ii. Every  $m$ -algebraic closure operator  $u$  on  $L$  satisfies ( $x \in A$  implies  $u(x) \in A$ ).

iii. Let  $x \in A$ ,  $y \in L$  and  $x \leq y$ . Then  $y \in A$ .

### PROOF

(i)  $\Rightarrow$  (ii): Evident.

(ii)  $\Rightarrow$  (iii): Suppose that the second condition holds and let  $x \in A$ ,  $y \in L$  and  $x \leq y$ . Define  $u : L \rightarrow L$  as follows:

$$u(z) = \begin{cases} y, & \text{if } z \leq y \\ 1_L, & \text{otherwise} \end{cases}$$

Evidently  $u$  is a closure operator. Suppose that  $X \subseteq L$  is  $m$ -directed. Either  $\bigvee_L X \leq y$  or  $\bigvee_L X \not\leq y$ . In the former case  $u(\bigvee_L X) = y$ . Also  $X \subseteq (y)$  and so  $u[X] = \{y\}$  implying  $\bigvee_L u[X] = y = u(\bigvee_L X)$ . In the latter case  $y$  is not an upperbound of  $X$  and so there exists  $w \in X$  with  $w \not\leq y$ . This means that  $u[X] \supseteq \{1_L\}$ . Therefore,  $\bigvee_L u[X] = 1_L$  and  $u(\bigvee_L X) = 1_L$ . Hence  $u$  is  $m$ -algebraic. Now the second condition above immediately yields  $u(x) \in A$  as  $x \in A$ . But  $u(x) = y$ , and so the third condition is true.

(iii)  $\Rightarrow$  (i): Suppose now that third condition holds and let  $u$  be a closure operator on  $L$ . Let  $x \in A$ . Then  $x \leq u(x)$  and so  $u(x) \in A$ , also.

### DEFINITION 1.24.

(a) A closure operator  $u : L \rightarrow L$  *preserves  $m$ -accessibility* if and only if for every  $x \in L$ ,  $x$   $m$ -accessible in  $L$  implies  $u(x)$   $m$ -accessible in  $u[L]$ .

(b) A closure operator  $u : L \rightarrow L$  *has  $m$ -accessible elements* if and only if there exists an element  $y \in u[L]$  such that  $y$  is  $m$ -accessible in  $u[L]$ .



REMARK 1.25.

Theorem 1.23 cannot be extended to incorporate Definition 1.24. A special case of Theorem 1.23 is:

*Let  $L$  be a complete lattice. The following conditions are equivalent:*

- i. Every closure operator  $u$  on  $L$  satisfies  $x$   $m$ -accessible in  $L$  only if  $u(x)$  is  $m$ -accessible in  $L$ .*
- ii. Every  $m$ -algebraic closure operator  $u$  on  $L$  satisfies  $x$   $m$ -accessible in  $L$  only if  $u(x)$  is  $m$ -accessible in  $L$ .*
- iii. Let  $x$  be  $m$ -accessible in  $L$  and  $x \leq y$ , then  $y$  is  $m$ -accessible in  $L$  also.*

On any complete lattice  $L$  with an  $m$ -accessible element there is a closure operator which does not preserve  $m$ -accessibility: merely set  $u(z) = 1_L$  for all  $z \in L$ . In fact if  $u[L]$  has no elements which are  $m$ -accessible in  $u[L]$  (for example if  $|u[L]| < m$ ) and  $L$  has an element which is  $m$ -accessible in  $L$  then  $u$  obviously does not preserve  $m$ -accessibility. However, even if we restrict our attention to closure operators  $u : L \rightarrow L$  for which  $u[L]$  has an element which is  $m$ -accessible in  $u[L]$ , we still find the condition of preserving  $m$ -accessibility to be restrictive.

THEOREM 1.26.

*Let  $L$  be a complete lattice where  $1_L$  is  $m$ -inaccessible. The following conditions are equivalent:*

- i. Every closure operator which has  $m$ -accessible elements preserves  $m$ -accessibility.*
- ii. There is at most one  $m$ -accessible element in  $L$ .*

PROOF

Suppose that the first condition holds but not the second. Then there exist  $x, y \in L \setminus \{1_L\}$  such that  $|\{x, y, 1_L\}| = 3$  and  $x$  and  $y$  are both  $m$ -accessible in  $L$ . Without loss of generality assume  $x \not\leq y$ . Now define  $u : L \rightarrow L$  by setting for each  $z \in L$ ,

$$u(z) = \begin{cases} z, & \text{if } z \leq y \\ 1_L, & \text{otherwise} \end{cases}$$

It is readily verified that  $u$  is a closure operator. Now  $y$  is  $m$ -accessible and so there exists  $m$ -directed  $Y \subseteq L$  with no maximum element such that  $y = \bigvee_L Y$ . Evidently  $y = u(y) = \bigvee_{u[L]} u[Y] = \bigvee_{u[L]} Y$ . So  $y$  is  $m$ -accessible in  $u[L]$ , i.e.  $u : L \rightarrow L$  has  $m$ -accessible elements. Also  $u[L] = (y) \cup \{1_L\}$  and so  $1_L$  is not  $m$ -accessible in  $u[L]$ . Moreover  $u(x) = 1_L$  and so we have contradicted the first condition.

Suppose now that the second condition holds and let  $u : L \rightarrow L$  be a closure operator having  $m$ -accessible elements. Let  $x$  be  $m$ -accessible in  $L$ . So  $x \neq 1_L$ . There exists  $y \in u[L]$  and  $Y \subseteq u[L]$ ,  $Y$   $m$ -directed with no maximum element such that  $y = \bigvee_{u[L]} Y$ . As  $Y$  has no maximum element,  $\bigvee_L Y$  is  $m$ -accessible in  $L$  ( $\bigvee_L Y \neq 1_L$ ) and so we have that  $x = \bigvee_L Y$ . But then  $u(x) = u(\bigvee_L Y) = \bigvee_{u[L]} Y = y$ , and so  $u$  preserves  $m$ -accessibility.

REMARK 1.27.

Consider the third condition of Lemma 1.11 yet again. In Remark 1.15 it was motivated that  $m$ -algebraic closure operators differ from closure operators that are not  $m$ -algebraic, in that an  $m$ -algebraic closure operator  $u$  determines the image of an  $m$ -accessible element in terms of the  $u$ -images of certain elements strictly below  $x$ . In Remark 1.18 we saw that an  $m$ -algebraic closure operator only satisfies  $x$   $m$ -accessible in  $L$  implies  $u(x)$   $m$ -accessible in  $L$  or  $u[L]$  in very restricted situations. Continuing with the notation of Lemma 1.11(iii), if  $y \in L$  and  $y \leq \bigvee_L X$  then

$u(y) \leq u(\bigvee_L X) = \bigvee_L u[X]$ . Thus an  $m$ -algebraic closure operator  $u$  restricts the values of  $u(y)$  where  $y \leq \bigvee_L X$  in that  $u(y) \leq \bigvee_L u[X]$  must be satisfied. Under what conditions will this definitely hold? Well certainly if  $y \leq w \in X$  (stronger than  $y \leq \bigvee_L X$ ) then any closure operator  $u$  will satisfy  $u(y) \leq u(w) \leq \bigvee_L u[X]$ . For an  $m$ -algebraic closure operator  $\bigvee_L u[X] = \bigvee_{u[L]} u[X]$  by the fourth condition of Lemma 1.11. Thus for such an operator we have shown: If  $y \leq w \in X$  (a stronger condition than  $y \leq \bigvee_L X$ ) we have  $u(y) \leq u(w) \in u[X]$  (a stronger condition than  $u(y) \leq \bigvee_{u[L]} u[X]$ ). The following definition has now been motivated:

**DEFINITION 1.28.**

- a) An element  $y$  of a complete lattice  $L$  is *weak  $m$ -compact* if for every  $m$ -directed  $X \subseteq L$  such that  $y \leq \bigvee_L X$  there exists  $w \in X$  such that  $y \leq w$ .
- b) A closure operator  $u : L \rightarrow L$  *preserves weak  $m$ -compactness* iff  $y$  weak  $m$ -compact in  $L$  implies that  $u(y)$  weak  $m$ -compact in  $u[L]$ .

**LEMMA 1.29.**

*Let  $L$  be a complete lattice and  $m$  and  $n$  infinite cardinals.*

- i. If  $m \leq n$  then  $x$  is weak  $m$ -compact in  $L$  implies that  $x$  is weak  $n$ -compact in  $L$ .*
- ii. Element  $x$  is weak  $m$ -compact in  $L$  if and only if  $x$  is weak  $\bar{m}$ -compact in  $L$ .*

**PROOF**

(i) Suppose  $m \leq n$  and  $x$  is weak  $m$ -compact in  $L$ . Let  $X \subseteq L$ ,  $X$   $n$ -directed and  $x \leq \bigvee_L X$ . But then  $X$   $n$ -directed implies that  $X$  is  $m$ -directed and since  $x$  is weak  $m$ -compact there exists  $y \in X$  such that  $x \leq y$  and so,  $x$  is weak  $n$ -compact.

(ii) Clearly  $m \leq \bar{m}$  and so the forward implication is true by (i). For the converse we need only consider  $m$  singular. But then  $X$  is  $m^+$ -directed if and only if  $X$  is  $m$ -directed and the result follows.

REMARK 1.30.

Notice that we did not specify that  $y = \bigvee_L X$  in Definition 1.28 is  $m$ -accessible. However, if  $y \in X$  then let  $y = w$  and the condition is satisfied. So effectively we only need to consider the case  $y \notin X$ . Also the reason for using the term weak  $m$ -compact is only due to the fact that compact elements of complete lattices were studied before  $m$ -algebraic closure operators and the immediate generalization to  $m$ -compactness differs slightly from the weak  $m$ -compactness defined here. The concept of  $m$ -compactness is defined later (in Chapter 2) and we first formalise the discussion of Remark 1.27 in the following theorem:

THEOREM 1.31.

*Let  $m$  and  $n$  be infinite cardinals such that  $m \leq \bar{n}$ . If  $u : L \rightarrow L$  is an  $m$ -algebraic closure operator, then  $u$  preserves weak  $n$ -compactness.*

PROOF

Let  $x \in L$  be weak  $n$ -compact in  $L$  and suppose  $u(x) \leq \bigvee_{u[L]} X$  where  $X \subseteq u[L]$  and  $X$  is  $n$ -directed. By Lemma 1.9(ii),  $X$  is  $\bar{n}$ -directed and as  $m \leq \bar{n}$ ,  $X$  is  $m$ -directed by Lemma 1.9(i). As  $u$  is  $m$ -algebraic we have:

$$x \leq u(x) \leq \bigvee_{u[L]} X = \bigvee_L X.$$

As  $x$  is weak  $n$ -compact in  $L$ , there exists  $y \in X$  such that  $x \leq y$ . Hence  $u(x) \leq u(y) = y$ , and so  $u(x)$  is weak  $n$ -compact in  $u[L]$ .

REMARK 1.32.

We show that the restriction  $m \leq \bar{n}$  in the above theorem cannot be dropped:

Let  $m$  and  $n$  be infinite cardinals such that  $\bar{n} < m$ . Then there exists a complete lattice  $L$  and an  $m$ -algebraic closure operator  $u : L \rightarrow L$  which does not preserve weak  $n$ -compactness.

Consider the following diagram of  $L$  where we define  $u : L \rightarrow L$  by:

$$u(z) = \begin{cases} z, & \text{if } z < y \\ 1_L, & \text{otherwise} \end{cases}$$

Now  $|L| = \bar{n} < m$  and hence  $u$  is trivially  $m$ -algebraic. Also it is readily verified that  $x$  is weak  $n$ -compact in  $L$ , but  $u(x)$  is not weak  $n$ -compact in  $u[L] = \{0_L\} \cup X \cup \{1_L\}$  as  $u(x) = 1_L = \bigvee_{u[L]} X$ . So  $u$  does not preserve weak  $n$ -compactness.

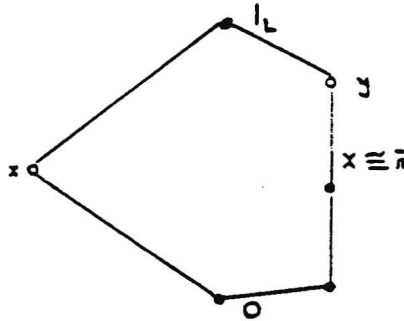

DIAGRAM 1.3.

REMARK 1.33.

Theorem 1.31 can evidently be stated as :

Let  $m$  and  $n$  be infinite cardinals such that  $m \leq \bar{n}$ . For any complete lattice  $L$  and any  $m$ -algebraic closure operator  $u : L \rightarrow L$ , and  $x \in L$  such that  $x$  is weak  $n$ -compact in  $L$  we have  $u(x)$  is weak  $n$ -compact in  $u[L]$ .

This format motivates:

DEFINITION 1.34.

Let  $m, n$  and  $k$  be infinite cardinals. Then  $\Phi\langle m, n, k \rangle$  denotes the following statement:

For any complete lattice  $L$  and any  $m$ -algebraic closure operator  $u : L \rightarrow L$ , if  $x$  is weak  $n$ -compact in  $L$  then  $u(x)$  is weak  $k$ -compact in  $u[L]$ .

THEOREM 1.35.

The statement  $\Phi\langle m, n, k \rangle$  is true if and only if  $m \leq \bar{k}$  and  $n \leq \bar{k}$ .

PROOF

( $\Rightarrow$ ):) Suppose  $\bar{k} < n$  and consider the complete lattice  $L$  described by the following diagram and define  $u : L \rightarrow L$  by

$$u(z) = \begin{cases} z, & \text{if } z < y \\ y, & \text{otherwise} \end{cases}$$

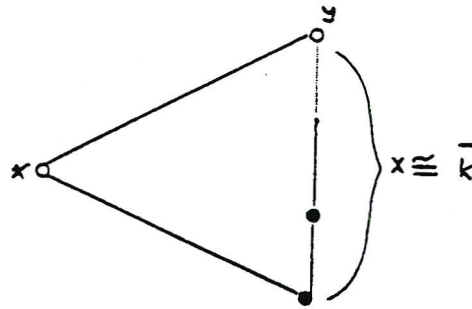

DIAGRAM 1.4.

Then  $u$  is evidently an ( $\omega$ -)algebraic closure operator and  $y$  is *not* weak  $k$ -compact in  $u[L]$  as  $y = \bigvee_{u[L]} X$ . But  $|L| = \bar{k}$  and so as  $\bar{k} < n$  we have  $x$  is weak  $n$ -compact in  $L$ . (In fact every element of  $L$  is weak  $n$ -compact in  $L$ ). So we have shown  $\Phi\langle \omega, n, k \rangle$  is false for  $\bar{k} < n$ . By Corollary 1.14(i) any  $\omega$ -algebraic closure operator is also  $m$ -algebraic for any infinite cardinal  $m$ . Hence  $\Phi\langle m, n, k \rangle$  is false whenever  $\bar{k} < n$ . So

the truth of  $\Phi\langle m, n, k \rangle$  implies  $n \leq \bar{k}$ . We need to show that the truth of  $\Phi\langle m, n, k \rangle$  also implies  $m \leq \bar{k}$ . Suppose  $\bar{k} < m$  and consider the example of Remark 1.32 where we replace  $n$  by  $k$ . The element  $x$  of lattice  $L$  is easily seen to be weak ( $\omega$ -)compact. Hence this example shows  $\Phi\langle m, \omega, k \rangle$  is false whenever  $\bar{k} < m$ . But Lemma 1.30(i) shows that  $x$  is weak  $n$ -compact for any infinite cardinal  $n$ . Thus this example shows  $\Phi\langle m, n, k \rangle$  is false whenever  $\bar{k} < m$ . So  $\Phi\langle m, n, k \rangle$  true implies  $m \leq \bar{k}$  and  $n \leq \bar{k}$ .

( $\Leftarrow$ ):) For the converse suppose that  $m, n$  and  $k$  are infinite cardinals with  $m \leq \bar{k}$  and  $n \leq \bar{k}$ . Theorem 1.31 shows that  $\Phi\langle m, k, k \rangle$  is true. Hence by Lemma 1.29(ii) we have  $\Phi\langle m, \bar{k}, k \rangle$  is true. Suppose  $u : L \rightarrow L$  is an  $m$ -algebraic closure operator and  $x$  is weak  $n$ -compact in  $L$ . Then  $x$  is weak  $\bar{k}$ -compact as  $n \leq \bar{k}$  and Lemma 1.29(i) holds. As  $\Phi\langle m, \bar{k}, k \rangle$  is true, this implies  $u(x)$  is weak  $k$ -compact. Hence  $\Phi\langle m, n, k \rangle$  is true.

### DEFINITION 1.36.

Let  $L$  be a complete lattice,  $u : L \rightarrow L$  a closure operator and  $m$  an infinite cardinal. We extend Definition 1.28:

An element  $y \in L$  is *weak  $m$ -compact in  $u[L]$*  if for every  $m$ -directed subset  $X \subseteq u[L]$ ,  $y \leq \bigvee_{u[L]} X$  implies that there exists  $w \in X$  with  $y \leq w$ .

(This extends Definition 1.28 as we allow elements of  $L \setminus u[L]$  to be weak  $m$ -compact in  $u[L]$ ). Further we define:

$$\begin{aligned} W_m(L) &= \{y \in L; y \text{ is weak } m\text{-compact in } L\}, \\ W_m(u[L]) &= \{y \in L; y \text{ is weak } m\text{-compact in } u[L]\} \end{aligned}$$

Also define for  $x \in L$ :

$$\begin{aligned} W(m, x, L) &= \{y; y \leq x \text{ and } y \in W_m(L)\}, \text{ and} \\ W(m, x, u[L]) &= \{y; y \leq x \text{ and } y \in W_m(u[L])\}. \end{aligned}$$

(Note that  $W_m(u[L])$  is not necessarily a subset of  $u[L]$ .)

LEMMA 1.37.

*Let  $u : L \rightarrow L$  be a closure operator and  $x \in L$ . Then  $x$  is weak  $m$ -compact in  $u[L]$  if and only if  $u(x)$  is weak  $m$ -compact in  $u[L]$ .*

PROOF

( $\Rightarrow$ ): Suppose that  $u(x) \leq \bigvee_{u[L]} X$  where  $X \subseteq u[L]$  and  $X$  is  $m$ -directed. Then  $x \leq \bigvee_{u[L]} X$  and hence for some  $y \in X$ ,  $x \leq y$ . But  $y \in u[L]$  and so  $u(x) \leq y$ .

( $\Leftarrow$ ): Suppose  $x \leq \bigvee_{u[L]} X$  where  $X \subseteq u[L]$  and  $X$  is  $m$ -directed. Then  $u(x) \leq \bigvee_{u[L]} X$  and hence for some  $y \in X$ ,  $u(x) \leq y$ . But then  $x \leq y$  also.

THEOREM 1.38.

*Let  $L$  be a complete lattice and  $u : L \rightarrow L$  a closure operator. The following conditions are equivalent:*

- i.  $u$  preserves weak  $m$ -compactness.*
- ii. For all  $x \in L$ ,  $x$  weak  $m$ -compact in  $L$  implies that  $x$  is weak  $m$ -compact in  $u[L]$ .*
- iii. For all  $x \in L$ ,  $W(m, x, L) \subseteq W(m, x, u[L])$ .*
- iv. For all  $x \in L$ ,  $x$   $m$ -accessible in  $L$  implies that  $W(m, u(x), L) \subseteq W(m, u(x), u[L])$ .*
- v. For all  $x \in L$ ,  $x$   $m$ -accessible in  $u[L]$  implies that  $W(m, x, L) \subseteq W(m, x, u[L])$ .*
- vi. For all  $x \in L$ ,  $x$   $m$ -accessible in  $L$  via  $u[L]$  implies  $W(m, x, L) = W(m, u(x), L)$ .*



PROOF

(i)  $\Leftrightarrow$  (ii): Direct from Lemma 1.37.

(i)  $\Rightarrow$  (iii): Let  $y \in W(m, x, L)$ , that is  $y \leq x$  and  $y$  is weak  $m$ -compact in  $L$ . Hence  $u(y)$  is weak  $m$ -compact in  $u[L]$ . So by Lemma 1.37 this implies that  $y$  is weak  $m$ -compact in  $u[L]$ , that is  $y \in W(m, x, u[L])$  and so the third condition holds.

(iii)  $\Rightarrow$  (iv): Evident.

(iv)  $\Rightarrow$  (v): Let  $x$  be  $m$ -accessible in  $u[L]$ . Then  $x = \bigvee_{u[L]} X$  where  $X \subseteq u[L]$ ,  $X$  is  $m$ -directed and  $x \notin X$ . Then  $\bigvee_L X \notin X$  also and hence  $\bigvee_L X$  is  $m$ -accessible in  $L$ . Further  $u(\bigvee_L X) = \bigvee_{u[L]} X = x$  and so by (iv)  $W(m, x, L) \subseteq W(m, x, u[L])$  and so the fifth condition is true.

(v)  $\Rightarrow$  (i): Let  $x$  be weak  $m$ -compact in  $L$ . Further suppose that  $u(x) \leq \bigvee_{u[L]} X$  where  $X$  is  $m$ -directed,  $X \subseteq u[L]$ . If  $X$  has a maximum element, then evidently  $u(x) \leq \bigvee_{u[L]} X \in X$ . On the other hand, suppose that  $X$  has no maximum element. Then  $\bigvee_{u[L]} X$  is  $m$ -accessible in  $u[L]$ , and  $x \in W(m, \bigvee_{u[L]} X, L)$  and so  $x \in W(m, \bigvee_{u[L]} X, u[L])$ . Hence  $x$  is weak  $m$ -compact in  $u[L]$ . Therefore by Lemma 1.37,  $u(x)$  is weak  $m$ -compact in  $u[L]$  and so the first condition is true.

(vi)  $\Rightarrow$  (i): Let  $x \in W_m(L)$ . We need to show  $u(x) \in W_m(u[L])$ . So let  $X \subseteq u[L]$ ,  $X$   $m$ -directed such that  $u(x) \leq_L \bigvee_{u[L]} X$ . If  $X$  has a maximum element then  $u(x) \leq_L \bigvee_{u[L]} X \in X$ . Else  $X$  has no maximum element and so  $\bigvee_L X$  is  $m$ -accessible in  $L$  via  $u[L]$ . Therefore  $W(m, \bigvee_L X, L) = W(m, \bigvee_{u[L]} X, L)$ . Moreover as  $x \leq u(x)$ ,  $x \in W(m, \bigvee_{u[L]} X, L)$  Hence  $x \leq \bigvee_L X$ . Therefore there exists  $w \in X$  such that  $x \leq w$  implying  $u(x) \leq w$  also.

(i)  $\Rightarrow$  (vi): Trivially  $W(m, x, L) \subseteq W(m, u(x), L)$ . Conversely, let  $y \in W(m, u(x), L)$ , where  $x$  is  $m$ -accessible in  $L$  via  $u[L]$ . Therefore  $y \in W_m(L)$  and  $y \leq u(x)$ . By (i)  $u(y)$  is weak  $m$ -compact in  $u[L]$ . Further  $x = \bigvee_L X$  where  $X \subseteq u[L]$ ,  $X$   $m$ -directed. Now  $u(y) \leq u(x) = \bigvee_{u[L]} X$ . Hence there exists  $w \in X$  such that  $u(y) \leq w$ . Further

$w \leq \bigvee_L X = x$ . Therefore  $y \leq u(y) \leq x$  and  $y \in W(m, x, L)$ .

**THEOREM 1.39.**

*Let  $L$  be a complete lattice where  $1_L$  is  $m$ -inaccessible. Then  $y$  is weak  $m$ -compact in  $L$  if and only if for every closure operator  $u : L \rightarrow L$  and  $X \subseteq L$ ,  $X$   $m$ -directed in  $L$ ,  $y \leq \bigvee_L X$  implies that  $u(y) \leq \bigvee_L u[X]$ .*

**PROOF**

( $\Rightarrow$ ): Let  $u : L \rightarrow L$  be a closure operator and  $y \leq \bigvee_L X$ . Then for some  $x \in X$ ,  $y \leq x$ . Hence  $u(y) \leq u(x) \leq \bigvee_L u[X]$ .

( $\Leftarrow$ ): Conversely suppose  $y$  is not weak  $m$ -compact in  $L$ . Then  $y \leq \bigvee_L X$  for some  $X \subseteq L$ ,  $X$   $m$ -directed, but for each  $x \in X$ ,  $y \not\leq x$ . Define  $u : L \rightarrow L$  by setting:

$$u(z) = \begin{cases} z, & \text{if } z \leq x, \text{ for some } x \in X \\ 1_L, & \text{otherwise} \end{cases}$$

It is readily verified that  $u : L \rightarrow L$  is a closure operator. However,  $u[X] = X$  and so  $\bigvee_L u[X] = \bigvee_L X$ . As  $X$  has no maximum element,  $\bigvee_L u[X] = \bigvee_L X \neq 1_L$ . But  $u(y) = 1_L$ . This contradiction shows that  $y$  is indeed weak  $m$ -compact in  $L$ .

**THEOREM 1.40.**

*Let  $L$  be a complete lattice. The following conditions are equivalent:*

- i. Every closure operator  $u : L \rightarrow L$  preserves weak  $m$ -compactness.*
- ii. For all  $x, y \in L \setminus \{1_L\}$  where  $x$  is weak  $m$ -compact in  $L$  and  $y$  is  $m$ -accessible in  $L$ , we have that  $x \leq y$ .*
- iii. For all  $x, y \in L$ ,  $x \leq y$ ,  $x$   $m$ -accessible in  $L$ , we have  $W(m, x, L) = W(m, y, L)$ .*

PROOF

(i)  $\Rightarrow$  (ii): Suppose that the first condition holds but the second does not. Then there exists  $x, y \in L \setminus \{1_L\}$  where  $x$  is weak  $m$ -compact in  $L$  and  $y$  is  $m$ -accessible in  $L$ , but  $x \not\leq y$ . Obviously, the  $m$ -accessibility of  $y$  means that there exists  $X$ ,  $m$ -directed,  $X \subseteq L$  and  $y = \bigvee_L X \notin X$ . Define  $u : L \rightarrow L$  by setting for each  $z \in L$ ,

$$u(z) = \begin{cases} z, & \text{if } z \leq w, \text{ for some } w \in X \\ 1_L, & \text{otherwise} \end{cases}$$

Then  $u : L \rightarrow L$  is evidently a closure operator. However  $X$   $m$ -directed implies that  $(X)_L = \{y \in L; \text{there exists } x \in X \text{ and } y \leq x\}$  is  $m$ -directed. Further from the definition of  $u$ ,  $u[L] = (X)_L \cup \{1_L\}$  and hence  $\bigvee_{u[L]}(X) = 1_L$  and so  $1_L$  is not weak  $m$ -compact in  $u[L]$ . However,  $u(x) = 1_L$  and so  $u$  is not weak  $m$ -compact preserving.

(ii)  $\Rightarrow$  (i): To show that the second condition implies the first let  $u : L \rightarrow L$  be a closure operator and let  $x$  be weak  $m$ -compact in  $L$ . Let  $u(x) \leq \bigvee_{u[L]} Y$  where  $Y$  is  $m$ -directed,  $Y \subseteq u[L]$ . If  $Y$  has a maximum element then  $u(x) \leq \bigvee_{u[L]} Y \in Y$ . Otherwise  $Y$  has no maximum element and thus  $\bigvee_L Y$  is  $m$ -accessible in  $L$ . By the second condition  $x \leq \bigvee_L Y$  and the weak  $m$ -compactness of  $x$  yields  $x \leq z$  for some  $z \in Y$ . Hence  $u(x) \leq z$  also. Thus  $u(x)$  is weak  $m$ -compact in  $u[L]$ .

(ii)  $\Leftrightarrow$  (iii): Suppose that the second condition holds and  $x$   $m$ -accessible in  $L$ . Let  $y \in L$ ,  $x \leq y$ . Then  $W(m, x, L)$  is the set of all weak  $m$ -compact elements. Therefore  $W_m(L) = W(m, x, L) \subseteq W(m, y, L) \subseteq W_m(L)$ . Hence we have that  $W(m, x, L) = W(m, y, L)$  and the third condition is satisfied. Suppose now that the third condition holds,  $x$  weak  $m$ -compact and  $y$   $m$ -accessible in  $L$ . As  $y \leq 1_L$ ,  $W(m, y, L) = W(m, 1_L, L) = W_m(L)$  and  $x \in W_m(L)$  implies  $x \leq y$ .

REMARK 1.41.

It follows from Theorem 1.31 that for any infinite cardinal  $m$ , every  $m$ -algebraic closure operator is also a weak  $m$ -compact preserving closure operator. We proceed with an investigation of the converse situation.

LEMMA 1.42.

Let  $u : L \rightarrow L$  be a closure operator preserving weak  $m$ -compactness. Then  $u : L \rightarrow L$  is an  $m$ -algebraic closure operator if and only if for every  $x \in L$  if  $x$  is  $m$ -accessible in  $L$  via  $u[L]$  and  $x < u(x)$  then  $W(m, x, L) \subset W(m, u(x), L)$ .

PROOF

( $\Rightarrow$ ): If  $u$  is  $m$ -algebraic then for any  $x \in L$ ,  $x$   $m$ -accessible in  $L$  via  $u[L]$ , we have  $x = u(x)$  by Lemma 1.11(i). The result follows trivially.

( $\Leftarrow$ ): Let  $X \subseteq u[L]$ . We show  $\bigvee_L X = u(\bigvee_L X)$  (Lemma 1.11(i)). If  $\bigvee_L X \in X$  then the result is trivial. Else  $x = \bigvee_L X$  is  $m$ -accessible in  $L$  via  $u[L]$ . If  $x < u(x)$ , then  $W(m, x, L) \subset W(m, u(x), L)$  contrary to Theorem 1.38(vi). Hence  $x = u(x)$ .

THEOREM 1.43.

Let  $m$  be an infinite cardinal and  $L$  a complete lattice. The following conditions are equivalent:

- i. Every closure operator  $u : L \rightarrow L$  which is weak  $m$ -compact preserving is also  $m$ -algebraic.
- ii. For every  $x, y \in L$ ,  $x$   $m$ -accessible in  $L$ ,  $x < y$  we have  $W(m, x, L) \subset W(m, y, L)$ .

PROOF

(i)  $\Rightarrow$  (ii): Assume (i) but not (ii). Hence, there exists  $x, y \in L$ ,  $x$   $m$ -accessible in  $L$ ,  $x < y$  and  $W(m, x, L) = W(m, y, L)$ . Define  $u : L \rightarrow L$  by setting for each  $z \in L$ :

$$u(z) = \begin{cases} z, & \text{if } z < x \\ z \vee y, & \text{otherwise} \end{cases}$$

Then  $u$  is a closure operator. We show that  $u$  is weak  $m$ -compact preserving. Firstly notice that

$$u[L] = ((x)_L \setminus \{x\}) \cup [y]_L.$$

Let  $(x)_L \setminus \{x\}$  be denoted by  $A$ . By Theorem 1.38(vi), we need to show that if  $a$  is  $m$ -accessible in  $L$  via  $u[L]$  then  $W(m, a, L) = W(m, u(a), L)$ . So there exists  $Y \subseteq u[L]$ ,  $Y$   $m$ -directed such that  $a = \bigvee_L Y \notin Y$ .

Case 1.  $Y \subseteq A$ : Implies that for all  $z \in Y$ ,  $u(z) = z$  and  $a \leq \bigvee_L A = x$ .

If  $a < x$  then  $u(a) = a$ .

If  $a = x$  then  $u(a) = y$ .

Case 2.  $Y \cap [y]_L \neq \emptyset$ : Then  $y \leq \bigvee_L Y = a$  and so  $a \not< x$ . Hence  $u(a) = a \vee y = a$ .

Hence we have shown that  $u$  is weak  $m$ -compact preserving. However,  $u$  is not  $m$ -algebraic, for  $x = \bigvee_L X$  for some  $m$ -directed  $X \subseteq A \subseteq u[L]$  and  $x < u(x)$  which contradicts Lemma 1.11(i) and hence also condition (i).

(ii)  $\Rightarrow$  (i): Let (ii) hold and  $u : L \rightarrow L$  be weak  $m$ -compact preserving. By Lemma 1.11(i), let  $X \subseteq u[L]$  be  $m$ -directed such that  $x = \bigvee_L X \notin X$ . Suppose  $\bigvee_L X < u[\bigvee_L X]$ . Since  $X \subseteq u[L]$  we have that  $x$  is  $m$ -accessible in  $L$  via  $u[L]$ . By (ii)  $W(m, x, L) \subset W(m, u(x), L)$ . But this contradicts Theorem 1.38(vi). Hence  $\bigvee_L X = u(\bigvee_L X)$  and so  $u$  is an  $m$ -algebraic closure operator.

REMARK 1.44.

It was shown in Theorem 1.38 and Lemma 1.42 that the set  $W(m, x, L)$  is sig-

nificant in the study of closure operators which preserve weak  $m$ -compactness. The next two lemmas explore this set further.

LEMMA 1.45.

Let  $L$  be a complete lattice and  $x \in L$ . Then

- i.  $W(m, x, L)$  is  $m$ -directed.
- ii. Let  $x$  be  $m$ -inaccessible. Then  $x$  is weak  $m$ -compact if and only if  $x = \bigvee_L W(m, x, L)$ .

PROOF

(i) Let  $Y \subseteq W(m, x, L)$  where  $|Y| < m$ . We show  $\bigvee_L Y \in W(m, x, L)$  also and hence as  $\bigvee_L Y$  is an upperbound of  $Y$  the  $m$ -directedness of  $W(m, x, L)$  follows: Suppose  $\bigvee_L Y \leq \bigvee_L X$  where  $X$  is  $m$ -directed. Then for each  $y \in Y$  we have  $y \leq \bigvee_L X$  and so for each  $y \in Y$  there exists  $f(y) \in X$  satisfying  $y \leq f(y)$ . Now  $|\{f(y); y \in Y\}| \leq |Y| < m$  and hence there exists  $w \in X$  such that  $w$  is an upper bound of  $\{f(y); y \in Y\}$ . Consequently  $w$  is an upper bound of  $Y$  and so  $\bigvee_L Y \leq w$ . This shows that  $\bigvee_L Y \in W(m, x, L)$  as required.

(ii) Suppose  $x$  is weak  $m$ -compact. Then  $x \in W(m, x, L)$  and so  $x = \bigvee_L W(m, x, L)$ . Conversely suppose  $x = \bigvee_L W(m, x, L)$ . As  $x$  is  $m$ -inaccessible we must have  $x \in W(m, x, L)$  and so  $x$  is weak  $m$ -compact in  $L$ .

LEMMA 1.46.

Let  $L$  be a complete lattice. The following conditions are equivalent:

- i. Every  $m$ -inaccessible element of  $L$  is weak  $m$ -compact.
- ii. For each  $x \in L$ , if  $\bigvee_L W(m, x, L) < x$  then  $x$  is  $m$ -accessible in  $L$ .

PROOF

(i)  $\Rightarrow$  (ii): Let  $x \in L$  with  $\bigvee_L W(m, x, L) < x$ . If  $x$  is  $m$ -inaccessible then condition (i) implies  $x$  is weak  $m$ -compact and so  $x \in W(m, x, L)$  which is impossible. Thus  $x$  is  $m$ -accessible in  $L$ .

(ii)  $\Rightarrow$  (i): Suppose (ii) holds. Let  $x$  be  $m$ -inaccessible in  $L$ . By (ii) we conclude  $\bigvee_L W(m, x, L) = x$ . But as  $x$  is  $m$ -inaccessible, we must have  $x \in W(m, x, L)$ , i.e.  $x$  is weak  $m$ -compact in  $L$ .

DEFINITION 1.47.

Let  $L$  be a complete lattice. Then  $L$  is a *weak  $m$ -algebraic* lattice if for every  $x \in L$ ,  $x = \bigvee_L W(m, x, L)$ .

COROLLARY 1.48.

*Let  $L$  be a weak  $m$ -algebraic lattice. Then a closure operator  $u : L \rightarrow L$  is  $m$ -algebraic if and only if  $u : L \rightarrow L$  is weak  $m$ -compact preserving.*

PROOF

By Theorem 1.31 the forward implication holds.

Conversely we use Theorem 1.43. Let  $x$  be  $m$ -accessible in  $L$  and  $x < y$ . Then

$$x = \bigvee_L W(m, x, L) < \bigvee_L W(m, y, L) = y.$$

Consequently  $W(m, x, L) \subset W(m, y, L)$ . Hence every weak  $m$ -compact preserving operator is  $m$ -algebraic.

REMARK 1.49.

Consider the complete lattice given in the following diagram:

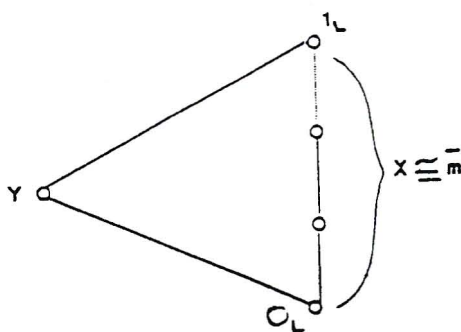

DIAGRAM 1.5.

Then by Theorem 1.22 every closure operator on  $L$  is  $m$ -algebraic. Also by Theorem 1.40 every closure operator on  $L$  is weak  $m$ -compact preserving. However  $L$  is not weak  $m$ -algebraic as  $W_m(L) = X$  and  $W(m, y, L) = \{0_L\}$ . Consequently  $\bigvee_L W(m, y, L) < y$ .

The converse implication of Corollary 1.48 is investigated deeper in Chapter 3. We now turn to considering weak  $m$ -compact reflecting closure operators.

DEFINITION 1.50.

Let  $u : L \rightarrow L$  be a closure operator on complete lattice  $L$ . Then  $u$  reflects weak  $m$ -compactness if for each  $x \in u[L]$ ,  $x$  weak  $m$ -compact in  $u[L]$ , there exists  $y \in W_m(L)$  such that  $u(y) = x$ .

THEOREM 1.51.

Let  $L$  be a complete lattice,  $m$  an infinite cardinal and  $u : L \rightarrow L$  a closure operator. The following conditions are equivalent:

- i.  $u : L \rightarrow L$  reflects weak  $m$ -compactness.
- ii. For each  $x \in u[L]$ ,  $x$  weak  $m$ -compact in  $u[L]$ ,  $u(\bigvee_L W(m, x, L)) = x$ .



PROOF

(i)  $\Rightarrow$  (ii): As  $x \in W_m(u[L]) \subseteq u[W_m(L)]$ , there exists  $z \in W_m(L)$  such that  $x = u(z)$ . Then  $z \leq \bigvee_L W(m, x, L) \leq x$  and so

$$x = u(z) \leq u\left(\bigvee_L W(m, x, L)\right) \leq u(x) = x.$$

Thus  $x = u(\bigvee_L W(m, x, L))$  as required.

(ii)  $\Rightarrow$  (i): Let  $x \in u[L] \cap W_m(u[L])$ . Then  $u(\bigvee_L W(m, x, L)) = x$ . Consequently  $x = \bigvee_{u[L]} u[W(m, x, L)]$ . As  $x \in W_m(u[L])$  there exists  $y \in u[W(m, x, L)]$  such that  $x \leq y$ . But  $y = u(z)$  for some  $z \in W(m, x, L)$ . So we have

$$x \leq y = u(z) \leq u(x) = x.$$

Hence  $x = u(z)$  as required.

THEOREM 1.52.

*Let  $m, n$  be infinite cardinals where  $m \leq \bar{n}$ . Then every closure operator  $u : L \rightarrow L$ , where  $L$  is a weak  $m$ -algebraic lattice, reflects weak  $n$ -compactness.*

PROOF

Let  $L$  be a weak  $m$ -algebraic lattice. Then for any  $x \in u[L]$ ,  $x = \bigvee_L W(m, x, L)$ . However by Lemma 1.29(i) and (ii)

$$W(m, x, L) \subseteq W(n, x, L) \subseteq (x)_L$$

and so  $x = \bigvee_L W(n, x, L)$ . Consequently

$$x = u(x) = u\left(\bigvee_L W(n, x, L)\right)$$

and by Theorem 1.51,  $u : L \rightarrow L$  reflects weak  $n$ -compactness.

REMARK 1.53.

We showed in Corollary 1.48 that on a weak  $m$ -algebraic lattice the  $m$ -algebraic closure operators are precisely the weak  $m$ -compact preserving operators. In Remark 1.49 we showed that this condition does not imply the weak  $m$ -algebraicity of  $L$ . In contrast we have:

THEOREM 1.54.

*Let  $m$  be an infinite cardinal and  $L$  a complete lattice. The following conditions are equivalent :*

- i.  $L$  is a weak  $m$ -algebraic lattice.*
- ii. Every closure operator is weak  $m$ -compact reflecting.*
- iii. Every weak  $m$ -compact preserving closure operator is weak  $m$ -compact reflecting.*
- iv. Every  $m$ -algebraic closure operator is weak  $m$ -compact reflecting.*

PROOF

(i)  $\Rightarrow$  (ii): Follows from Theorem 1.52.

(ii)  $\Rightarrow$  (iii): Obvious.

(iii)  $\Rightarrow$  (iv): Follows from Theorem 1.31.

(iv)  $\Rightarrow$  (i): Suppose (iv) holds, but that  $L$  is not a weak  $m$ -algebraic lattice. Then there exists  $x \in L$  such that  $\bigvee_L W(m, x, L) < x$ . Define closure operator  $u : L \rightarrow L$  by setting for each  $z \in L$ :

$$u(z) = \begin{cases} z, & \text{if } z \leq \bigvee_L W(m, x, L) \\ x, & \text{if } z \leq x \text{ but } z \not\leq \bigvee_L W(m, x, L) \\ 1_L, & \text{otherwise.} \end{cases}$$

Then  $u$  is easily verified to be a closure operator. Now  $u[L] = (\bigvee_L W(m, x, L))_L \cup$

$\{x, 1_L\}$ . Hence  $x$  is weak  $(\omega)$ -compact in  $u[L]$  and so  $x$  is weak  $m$ -compact in  $u[L]$ . Now let  $w \in W_m(L)$ . We show  $u(w) \neq x$ . If  $w \leq \bigvee_L W(m, x, L)$  then  $u(w) = w \neq x$ . If  $w \leq x$  then automatically  $w \leq \bigvee_L W(m, x, L)$ . Consequently  $u(w) \neq x$ . The only other possibility is  $u(w) = 1_L$ . Now  $x \neq 1_L$  for if  $u(w) = x = 1_L$  then  $w \leq x$  and  $w \leq \bigvee_L W(m, x, L)$ , which would yield  $u(w) = w$ . But this contradicts the fact that  $w \in W_m(L)$  and  $x \notin W_m(L)$ . Thus we have shown that  $u$  is not a weak  $m$ -compact reflecting closure operator.

However  $u$  is  $m$ -algebraic. Take  $X \subseteq u[L]$ . By Lemma 1.11(i) we show  $\bigvee_L X = u(\bigvee_L X)$ . If  $X$  has a maximum element there is nothing to prove. Else  $z = \bigvee_L X$  is  $m$ -accessible in  $L$  via  $u[L]$ . From the structure of  $u[L]$ ,  $z \leq \bigvee_L W(m, x, L)$  and so  $u(z) = z$  as required. Thus this operator contradicts (iv) and we conclude that condition (iv) implies that  $L$  must be a weak  $m$ -algebraic lattice.

## CHAPTER 2

This chapter develops a slightly different generalisation of the well-known concept of compactness in complete lattices. For an infinite cardinal  $m$ ,  $m$ -compactness is defined and is shown to agree with weak  $m$ -compactness for regular  $m$ . Analogues of theorems developed in Chapter 1 are presented for the case of  $m$ -compactness. It is shown that only for regular  $m$  is an  $m$ -algebraic closure operator always  $m$ -compact preserving. Weak  $m$ -accessible elements of a closure operator are introduced in order to characterise the  $m$ -compact preserving closure operators. Corresponding to the concept of weak  $m$ -algebraic lattices in Chapter 1, the concept of  $m$ -algebraic lattices is defined. These lattices are characterised in terms of  $m$ -compact reflecting closure operator only for regular  $m$ .

DEFINITION 2.1.

Let  $L$  be a complete lattice. Then  $x \in L$  is  *$m$ -compact in  $L$*  if whenever  $x \leq \bigvee_L X$  there exists  $Y \subseteq X$  with  $|Y| < m$  and  $x \leq \bigvee_L Y$ .

LEMMA 2.2

*Let  $L$  be a complete lattice and  $m$  an infinite cardinal.*

- i. If  $x \in L$  is  $m$ -compact in  $L$  then  $x$  is weak  $m$ -compact in  $L$ .*
- ii. If  $x \in L$  is weak  $m$ -compact in  $L$  then  $x$  is  $\bar{m}$ -compact in  $L$ .*
- iii. If  $m$  is regular then  $x \in L$  is  $m$ -compact in  $L$  if and only if  $x$  is weak  $m$ -compact in  $L$ .*

PROOF

(i): Let  $x$  be  $m$ -compact in  $L$  and  $X \subseteq L$ , such that  $X$  is  $m$ -directed and

$x \leq \bigvee_L X$ . Then there exists  $Y \subseteq X$  such that  $|Y| < m$  and  $x \leq \bigvee_L Y$ . But,  $X$  is  $m$ -directed implies there exists  $w \in X$  such that  $y \leq w$  for all  $y \in Y$ . Thus  $\bigvee_L Y \leq w$  and so  $x \leq w$ .

(ii): We will show that for regular  $m$ ,  $x$  weak  $m$ -compact implies  $x$   $m$ -compact. Once this has been demonstrated, suppose that  $m$  is singular. If  $x$  is weak  $m$ -compact then  $x$  is weak  $\bar{m}$ -compact by Lemma 1.29. By the result for regular  $m$ , this implies that  $x$  is  $\bar{m}$ -compact.

So let  $m$  be regular, and  $x$  weak  $m$ -compact in  $L$ . Suppose  $x \leq \bigvee_L X$ ,  $X \subseteq L$ . We show that there exists  $Y \subseteq X$ ,  $|Y| < m$  such that  $x \leq \bigvee_L Y$ . If  $|X| < m$ , let  $Y = X$ . Else  $|X| \geq m$ . Then consider:

$$X^* = \left\{ \bigvee_L Y; Y \subseteq X \text{ and } |Y| < m \right\}$$

Since  $m$  is regular,  $X^*$  is  $m$ -directed in  $L$  and  $\bigvee_L X = \bigvee_L X^*$ , by Lemma 1.7. Hence there exists  $Y \subseteq X$ , such that  $|Y| < m$  with  $x \leq \bigvee_L Y$  as required.

(iii) follows from (i) and (ii).

### REMARK 2.3.

*For every singular cardinal  $m$  there exists a complete lattice  $L$  with  $|L| = 2^m$  such that  $1_L$  is weak  $m$ -compact in  $L$  but not  $m$ -compact in  $L$ :*

Consider a set  $A$  with  $|A| = m$ ,  $m$  singular. Let  $L = \exp A$  ordered by  $\subseteq$  and let  $X$  be an  $m$ -directed subset of  $\exp A$ . So each element of  $X$  is a subset of  $A$  (see diagram that follows). Suppose that  $\bigvee_L X = A$ , that is  $\bigcup X = A$ . We have that for each  $a \in A$  there exists  $S_a \in X$  such that  $a \in S_a$ . Therefore, by the axiom of choice,

$$|\{S_a; a \in A\}| \leq |A| = m < m^+.$$

But,  $X$  is also  $m^+$ -directed, by Lemma 1.9(ii). Hence there exists  $B \in X$  such that  $\bigcup_{a \in A} S_a \subseteq B$ . But then,  $A \subseteq \bigcup_{a \in A} S_a \subseteq B \subseteq A$ . Therefore,  $A = B$  which implies

that  $A \in X$ . So if  $A = \bigvee_L X$  where  $X$  is an  $m$ -directed subset of  $\exp A$  then  $A \in X$ . Therefore,  $A$  is weak  $m$ -compact. But also, let  $C = \{\{a\}; a \in A\}$ . Then  $A = \bigcup C$  and for  $D \subseteq C$  with  $|D| < |C| = m$ ,  $|\bigcup D| = |D| < m$  implying that  $\bigcup D \neq A$ . Hence  $A$  is not  $m$ -compact.

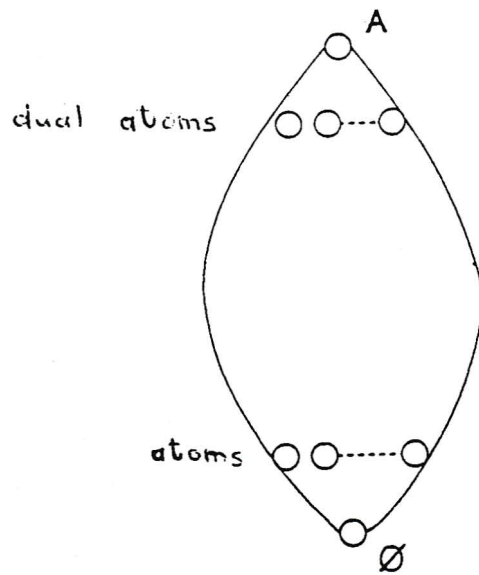

DIAGRAM 2.1.

DEFINITION 2.4.

Let  $L$  be a complete lattice and  $u : L \rightarrow L$  a closure operator.

(a) Closure operator  $u$  *preserves  $m$ -compactness* if and only if  $x$   $m$ -compact in  $L$  implies  $u(x)$   $m$ -compact in  $u[L]$ .

(b) An element  $y \in L$  is  *$m$ -compact in  $u[L]$*  if whenever  $y \leq \bigvee_{u[L]} X$  where  $X \subseteq u[L]$ , there exists  $Y \subseteq X$  with  $|Y| < m$  and  $y \leq \bigvee_{u[L]} Y$ .

(c) Let  $x \in L$ . We define the following subsets:

$$\begin{aligned}
C_m(L) &= \{y \in L; y \text{ is } m\text{-compact in } L\}, \\
C_m(u[L]) &= \{y \in L; y \text{ is } m\text{-compact in } u[L]\} \\
C(m, x, L) &= \{y; y \leq x \text{ and } y \in C_m(L)\}, \\
C(m, x, u[L]) &= \{y; y \leq x \text{ and } y \in C_m(u[L])\},
\end{aligned}$$

LEMMA 2.5.

*For infinite cardinals  $m$  and  $n$  with  $m \leq n$  we have  $C_m(L) \subseteq C_n(L)$ .*

PROOF

The proof follows directly from Definition 2.4.

LEMMA 2.6.

*Let  $u : L \rightarrow L$  be a closure operator and  $x \in L$ . Then  $x$  is  $m$ -compact in  $u[L]$  if and only if  $u(x)$  is  $m$ -compact in  $u[L]$ .*

PROOF

The proof follows from Definition 2.1 and Definition 2.4.

REMARK 2.7.

The aim of this chapter is to give results involving the concept of  $m$ -compactness analogous to those obtained for weak  $m$ -compactness in Chapter 1. One noteworthy difference between these two concepts is that Lemma 1.29(ii) does not transfer to the  $m$ -compactness case: By Remark 2.3 and Lemma 2.2(ii) there exists for every singular cardinal  $m$  a complete lattice  $L$  such that  $1_L$  is  $\bar{m}$ -compact in  $L$  but  $1_L$  is

not  $m$ -compact in  $L$ . We discuss the following results in the  $m$ -compact case. The results have been re-stated here for ease of reference:

2.7.1. Let  $m$  and  $n$  be infinite cardinals such that  $m \leq \bar{n}$ . If  $u : L \rightarrow L$  is an  $m$ -algebraic closure operator then  $u$  preserves weak  $n$ -compactness. (Theorem 1.31)

2.7.2. The statement  $\Phi(m, n, k)$  is true if and only if  $m \leq \bar{k}$  and  $n \leq \bar{k}$ . (Theorem 1.35)

2.7.3. Let  $L$  be a complete lattice and  $u : L \rightarrow L$  a closure operator. The following conditions are equivalent:

- (i)  $u$  preserves weak  $m$ -compactness.
- (ii) For all  $x \in L$ ,  $x$  weak  $m$ -compact in  $L$  implies that  $x$  is weak  $m$ -compact in  $u[L]$ .
- (iii) For all  $x \in L$ ,  $W(m, x, L) \subseteq W(m, x, u[L])$ .
- (iv) For all  $x \in L$  and  $x$   $m$ -accessible in  $L$  implies that  $W(m, u(x), L) \subseteq W(m, u(x), u[L])$ .
- (v) For all  $x \in L$  and  $x$   $m$ -accessible in  $u[L]$  implies that  $W(m, x, L) \subseteq W(m, x, u[L])$ .
- (vi) For all  $x \in L$  and  $x$   $m$ -accessible in  $L$  via  $u[L]$  implies  $W(m, x, L) = W(m, u(x), L)$ . (Theorem 1.38)

2.7.4. Let  $L$  be a complete lattice where  $1_L$  is  $m$ -inaccessible. Then  $y \in L$  is weak  $m$ -compact in  $L$  if and only if for every closure operator  $u : L \rightarrow L$  and  $X \subseteq L$ ,  $X$   $m$ -directed in  $L$ ,  $y \leq \bigvee_L X$  implies that  $u(y) \leq \bigvee_L u[X]$ . (Theorem 1.39)

2.7.5. Let  $L$  be a complete lattice. The following conditions are equivalent:

- (i) Every closure operator  $u : L \rightarrow L$  preserves weak  $m$ -compactness.
- (ii) For all  $x, y \in L \setminus \{1_L\}$  where  $x$  is weak  $m$ -compact in  $L$  and  $y$  is  $m$ -accessible in  $L$ , we have that  $x \leq y$ .
- (iii) For all  $x, y \in L$ ,  $x \leq y$ ,  $x$   $m$ -accessible in  $L$ , we have  $W(m, x, L) =$



$W(m, y, L)$ . (Theorem 1.40)

2.7.6. Let  $u : L \rightarrow L$ , be a closure operator preserving weak  $m$ -compactness. Then  $u : L \rightarrow L$  is an  $m$ -algebraic closure operator if and only if for every  $x \in L$  if  $x$  is  $m$ -accessible in  $L$  via  $u[L]$  and  $x < u(x)$  then  $W(m, x, L) \subset W(m, u(x), L)$ . (Lemma 1.42)

2.7.7. Let  $m$  be an infinite cardinal and  $L$  a complete lattice. The following conditions are equivalent:

(i). Every closure operator  $u : L \rightarrow L$  which is weak  $m$ -compact preserving is also  $m$ -algebraic.

(ii) For every  $x, y \in L$ ,  $x$   $m$ -accessible in  $L$ ,  $x < y$  we have  $W(m, x, L) \subset W(m, y, L)$ . (Theorem 1.43)

2.7.8. Let  $L$  be a complete lattice and  $x \in L$ . Then:

(i)  $W(m, x, L)$  is  $m$ -directed.

(ii) Let  $x$  be  $m$ -inaccessible. Then  $x$  is weak  $m$ -compact if and only if  $x = \bigvee_L W(m, x, L)$ . (Lemma 1.45)

2.7.9. Let  $L$  be a weak  $m$ -algebraic lattice. Then a closure operator  $u : L \rightarrow L$  is  $m$ -algebraic if and only if  $u : L \rightarrow L$  is weak  $m$ -compact preserving. (Corollary 1.48)

2.7.10. Let  $L$  be a complete lattice,  $m$  an infinite cardinal and  $u : L \rightarrow L$  a closure operator. The following conditions are equivalent:

(i)  $u : L \rightarrow L$  reflects weak  $m$ -compactness.

(ii) For each  $x \in u[L]$ ,  $x$  weak  $m$ -compact in  $u[L]$ ,  $u(\bigvee_L W(m, x, L)) = x$ . (Theorem 1.51)

2.7.11. Let  $m, n$  be infinite cardinals where  $m \leq \bar{n}$ . Then every closure operator  $u : L \rightarrow L$ , where  $L$  is a weak  $m$ -algebraic lattice, reflects weak  $n$ -compactness.

(Theorem 1.52)

2.7.12. Let  $m$  be an infinite cardinal and  $L$  a complete lattice. The following conditions are equivalent:

- (i)  $L$  is a weak  $m$ -algebraic lattice.
- (ii) Every closure operator is weak  $m$ -compact reflecting.
- (iii) Every weak  $m$ -compact preserving operator is weak  $m$ -compact reflecting.
- (iv) Every  $m$ -algebraic closure operator is weak  $m$ -compact reflecting. (Theorem 1.54)

### THEOREM 2.8.

Let  $m$  and  $n$  be infinite cardinals such that  $\bar{m} \leq n$ . If  $u : L \rightarrow L$  is an  $m$ -algebraic closure operator then  $u$  preserves  $n$ -compactness.

### PROOF

Let  $x \in L$  be  $n$ -compact in  $L$ . Suppose  $u(x) \leq \bigvee_{u[L]} X$  where  $X \subseteq u[L]$ . Define

$$X^* = \{ \bigvee_L Y; |Y| < \bar{m}, Y \subseteq X \}.$$

By Corollary 1.10,  $X^*$  is  $m$ -directed and  $\bigvee_L X = \bigvee_L X^*$ . Thus  $u(\bigvee_L X) = u(\bigvee_L X^*)$  i.e.  $\bigvee_{u[L]} X = \bigvee_{u[L]} u[X^*]$ . So:

$$x \leq u(x) \leq \bigvee_{u[L]} X = \bigvee_{u[L]} u[X^*] = \bigvee_L u[X^*].$$

The last equality follows as  $u[X^*]$  is  $m$ -directed and  $u$  is an  $m$ -algebraic closure operator. Now  $x$  is  $n$ -compact and so there exists  $Y \subseteq u[X^*]$  with  $|Y| < n$  and  $x \leq \bigvee_L Y$ . Thus  $u(x) \leq u(\bigvee_L Y) = \bigvee_{u[L]} Y$ . Further, by the axiom of choice, for each  $y \in Y$  there exists  $Z_y \subseteq X$  with  $|Z_y| < \bar{m}$  such that  $y = u(\bigvee_L Z_y) = \bigvee_{u[L]} Z_y$ .

So

$$u(x) \leq \bigvee_{u[L]} \{ \bigvee_{u[L]} Z_y; y \in Y \} = \bigvee_{u[L]} ( \bigcup_{y \in Y} Z_y ).$$

It is sufficient to show  $|\bigcup_{y \in Y} Z_y| < n$ . To this end notice

$$|\bigcup_{y \in Y} Z_y| \leq \sum_{y \in Y} |Z_y| \leq (\sup_{y \in Y} |Z_y|) \cdot |Y| \leq \max\{\sup_{y \in Y} |Z_y|, |Y|, \omega\}.$$

We consider two cases:

Case 1:  $m$  regular. Then  $m = \bar{m}$  and  $m \leq n$ .

If  $m = n$  then  $|Y| < m$  and  $|Z_y| < m$  for all  $y \in Y$  and hence  $|\bigcup_{y \in Y} Z_y| < m = n$ .

If  $m < n$  then  $\sup_{y \in Y} |Z_y| \leq m < n$  and  $|Y| < n$  and hence  $|\bigcup_{y \in Y} Z_y| < n$ .

Case 2:  $m$  singular. Then  $m < \bar{m} = m^+$  and  $m^+ \leq n$ .

If  $m^+ = n$  then  $|Y| < m^+$  and  $|Z_y| < m^+$  for all  $y \in Y$  and hence  $|\bigcup_{y \in Y} Z_y| < m^+ = n$  by the regularity of  $m^+$ .

If  $m^+ < n$  then  $\sup_{y \in Y} |Z_y| \leq m^+ < n$  and  $|Y| < n$  and hence  $|\bigcup_{y \in Y} Z_y| < n$ .

### REMARK 2.9.

We show that the restriction  $\bar{m} \leq n$  in the previous theorem cannot be dropped:

*Let  $m$  and  $n$  be infinite cardinals such that  $n < \bar{m}$ . Then there exists a complete lattice  $L$  and an  $m$ -algebraic closure operator  $u : L \rightarrow L$  which does not preserve  $n$ -compactness.*

To show this suppose first that  $\bar{n} < m$ . By Remark 1.32 there exists a complete lattice  $L$ , an  $m$ -algebraic closure operator  $u : L \rightarrow L$  and an element  $x \in L$  such that  $x$  is weak  $n$ -compact in  $L$  but  $u(x)$  is not weak  $n$ -compact in  $u[L]$ . In fact in the example given,  $x$  is weak  $\omega$ -compact. Hence by Lemma 2.2  $x$  is  $\omega$ -compact and hence  $n$ -compact in  $L$ . Further  $u(x)$  is not  $n$ -compact in  $u[L]$  for otherwise Lemma 2.2 (i) implies that  $u(x)$  is weak  $n$ -compact in  $u[L]$ . Thus we have our counter example for

the case  $\bar{n} < m$ .

Now suppose  $n < \bar{m}$  but  $\bar{n} \not\leq m$ . We claim that  $n$  is singular and ( $m = n$  or  $m = \bar{n}$ ): Suppose first that  $n$  is regular. Then  $n = \bar{n} < \bar{m}$ . If  $m$  is regular then  $\bar{n} < \bar{m} = m$  contradicting  $\bar{n} \not\leq m$ . If  $m$  is singular then  $m < m^+ = \bar{m}$  and so  $n < m^+$  which implies  $n \leq m$ . But  $n = m$  is impossible as  $n$  is supposed regular and  $m$  is singular. Thus  $n = \bar{n} < m$ , a contradiction again. So  $n$  is indeed singular. There are now two possibilities:  $m$  regular or  $m$  singular. If  $m$  is regular then  $n < \bar{m} = m$  and thus  $\bar{n} \leq m$ . As  $\bar{n} \not\leq m$  it follows that  $m = \bar{n}$ . If  $m$  is singular then  $n < \bar{m} = m^+$  and so  $n \leq m$ . However  $n < m$  implies that  $\bar{n} < m$  and so we conclude  $m = n$ .

So let  $n < \bar{m}$  where  $n$  is singular and  $m = n$  or  $m = \bar{n}$ . Consider the complete lattice  $L$  with the diagram that follows. Define  $u : L \rightarrow L$  by setting:

$$u(z) = \begin{cases} z, & \text{if } z < n \\ 1_L, & \text{otherwise} \end{cases}$$

Then  $x$  is  $\omega$ -compact and hence  $n$ -compact in  $L$  and  $u(x) = 1_L$  is not  $n$ -compact in  $u[L] = L \setminus \{x, n\}$  by Remark 2.3.

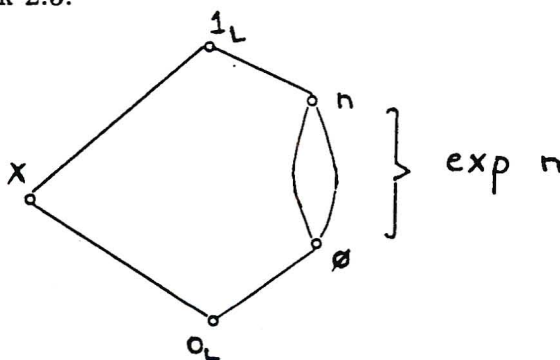

DIAGRAM 2.2.

It is now necessary only to show that  $u$  is  $m$ -algebraic. By Corollary 1.14  $u$  is  $n$ -algebraic if and only if  $u$  is  $\bar{n}$ -algebraic, so we only consider the case  $m = n$ . Let  $X \subseteq u[L]$ ,  $X$   $n$ -directed. We show  $\bigvee_L X = \bigvee_{u[L]} X$ . Suppose this is not the case. Then  $\bigvee_L X = x$  or  $\bigvee_L X = n$ . Evidently if  $\bigvee_L X = x$  then  $x \in X$  contradicting

$X \subseteq u[L]$ ! If  $\bigvee_L X = n$  then as  $n$  is weak  $n$ -compact in  $L$ ,  $n \in X$  again contradicting  $X \subseteq u[L]$ ! So  $u$  is indeed  $m$ -algebraic for  $m = n$  and  $m = \bar{n}$ .

DEFINITION 2.10.

Let  $m, n$  and  $k$  be infinite cardinals. Then  $\Psi\langle m, n, k \rangle$  denotes the following statement:

For any complete lattice  $L$  and any  $m$ -algebraic closure operator  $u : L \rightarrow L$ , if  $x$  is  $n$ -compact in  $L$ , then  $u(x)$  is  $k$ -compact in  $u[L]$ .

THEOREM 2.11.

*The statement  $\Psi\langle m, n, k \rangle$  is true if and only if  $\bar{m} \leq k$  and  $n \leq k$ .*

PROOF

( $\Rightarrow$ ): We first show  $\bar{m} \leq k$ . For suppose not. Then  $k < \bar{m}$  and by Remark 2.9 there exists a complete lattice  $L$ , an  $m$ -algebraic closure operator  $u : L \rightarrow L$ , an  $\omega$ -compact element  $x \in L$  such that  $u(x)$  is not  $k$ -compact in  $u[L]$ . Hence  $\Psi\langle m, \omega, k \rangle$  is false. But  $x$ , being  $\omega$ -compact in  $L$ , is also  $n$ -compact in  $L$  for any infinite cardinal  $n$ . Thus  $\Psi\langle m, n, k \rangle$  is false contrary to our assumptions. Hence  $\Psi\langle m, n, k \rangle$  true implies  $\bar{m} \leq k$ .

Consider now the complete lattice  $L$  described by Diagram 2.3. Define  $u : L \rightarrow L$  by:

$$u(z) = \begin{cases} z, & \text{if } z \in \exp k \\ k, & \text{otherwise} \end{cases}$$

Then  $u$  is evidently an  $(\omega-)$ algebraic closure operator and  $k$  is not  $k$ -compact in  $L$  or in  $u[L]$  by the argument used in Remark 2.3. (Note that it is irrelevant here whether  $k$  is regular or singular). However  $x$  is  $k^+$ -compact in  $L$ : Suppose  $x \leq \bigvee_L X$  where  $X \subseteq L$ . We may evidently assume  $x \notin X$ . Then  $\bigvee_L X = x$  or  $\bigvee_L X = k$ .

If  $\bigvee_L X = k$ , then  $X \subseteq \exp k$  and hence  $\bigvee_L X = \bigcup X = k$  and thus for each  $y \in k$  there exists  $a_y \in X$  with  $y \in a_y$ . Thus  $k = \bigcup_{y \in k} a_y = \bigvee_L \{a_y; y \in k\}$  and  $|\{a_y; y \in k\}| \leq k < k^+$ . Thus  $x$  is  $n$ -compact for each  $n > k$ . This shows  $\Psi(\omega, n, k)$  is false for  $n > k$  and hence  $\Psi(m, n, k)$  is false for any cardinal  $m$  and cardinals  $n > k$ . Thus  $\Psi(m, n, k)$  true implies  $n \leq k$ .

( $\Leftarrow$ ;) Theorem 2.8 shows that for  $\bar{m} \leq k$ ,  $\Psi(m, k, k)$  is true. But if  $n \leq k$  then  $x$   $n$ -compact in  $L$  implies  $x$   $k$ -compact in  $L$ . Hence  $\Psi(m, n, k)$  is true.

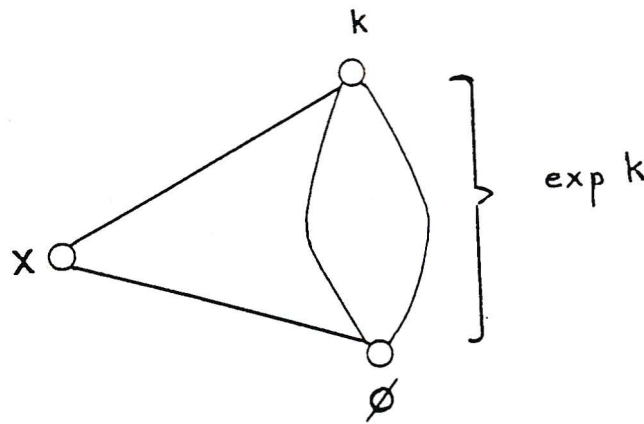

DIAGRAM 2.3.

**REMARK 2.12.**

(a) Note that for  $m$  singular  $\Phi(m, m, m)$  is true whereas  $\Psi(m, m, m)$  is false. Moreover  $\Psi(m, m, m^+)$  is true and  $m^+$  is the least value  $k$  such that  $\Psi(m, m, k)$  is true. In general we can say that for  $m$  singular and  $m \leq n$ ,  $\Psi(m, n, m^+.n)$  is true.

(b) To generalise 2.7.3 we need to consider elements more general than  $m$ -accessible elements.

**DEFINITION 2.13.**

Let  $L$  be a complete lattice and  $u : L \rightarrow L$  a closure operator. Let  $A \in \{L, u[L]\}$

and  $x \in L$ .

(a)  $x$  is weak  $m$ -accessible in  $A$  if there exists  $X \subseteq A$  such that  $x = \bigvee_A X$  and for each  $Y \subseteq X$  with  $|Y| < m$ ,  $\bigvee_A Y < x$ .

(b)  $x$  is weak  $m$ -accessible in  $L$  via  $u[L]$  if there exists  $X \subseteq u[L]$  such that  $x = \bigvee_L X$  and for each  $Y \subseteq X$  with  $|Y| < m$ ,  $\bigvee_{u[L]} Y < x$ .

COROLLARY 2.14.

For complete lattice  $L$ , closure operator  $u : L \rightarrow L$ , cardinals  $m$  and  $n$  with  $m \leq n$ :

- i. If  $x \in L$  is weak  $n$ -accessible in  $A$  then  $x$  is weak  $m$ -accessible in  $A$  where  $A \in \{L, u[L]\}$
- ii. If  $x \in L$  is weak  $n$ -accessible in  $L$  via  $u[L]$ , then  $x$  is weak  $m$ -accessible in  $L$  via  $u[L]$ .
- iii. For each  $x \in L$ , if  $x$  is weak  $m$ -accessible in  $L$  via  $u[L]$  then  $u(x)$  is weak  $m$ -accessible in  $u[L]$ .

PROOF

(i) and (ii) are trivial consequences of Definition 2.13.

(iii) For some  $X \subseteq u[L]$ ,  $x = \bigvee_L X$  where for each  $Y \subseteq X$  with  $|Y| < m$ ,  $\bigvee_{u[L]} Y < x$ . But  $u(x) = u(\bigvee_L X) = \bigvee_{u[L]} X$ .

LEMMA 2.15.

Let  $L$  be a complete lattice  $u : L \rightarrow L$  a closure operator,  $m$  an infinite cardinal and  $A \in \{L, u[L]\}$ .

- i. If  $x \in L$  is  $m$ -accessible in  $A$  then  $x$  is weak  $m$ -accessible in  $A$ .

- ii. If  $m$  is regular then  $x$  is  $m$ -accessible in  $A$  if and only if  $x$  is weak  $m$ -accessible in  $A$ .
- iii. If  $x \in L$  is  $m$ -accessible in  $L$  via  $u[L]$  then  $x$  is weak  $m$ -accessible in  $L$  via  $u[L]$ .
- iv. If  $m$  is regular then  $x$  is  $m$ -accessible in  $L$  via  $u[L]$  if and only if  $x$  is weak  $m$ -accessible in  $L$  via  $u[L]$ .

### PROOF

(i) Let  $x$  be  $m$ -accessible in  $A$ . Then there exists  $X \subseteq A$  where  $X$  is  $m$ -directed and  $x = \bigvee_A X \notin X$ . Suppose  $Y \subseteq X$  with  $|Y| < m$  and  $\bigvee_A Y \not\leq x$ . As  $\bigvee_A Y \leq \bigvee_A X$  we conclude  $\bigvee_A Y = x$ . But  $X$  is  $m$ -directed and so there exists  $w \in X$  such that for each  $y \in Y$ ,  $y \leq w$ . Hence

$$x = \bigvee_A Y \leq w \leq \bigvee_A X = x,$$

and so  $x = w \in X$ ! Thus no such  $Y$  exists and  $x$  is weak  $m$ -accessible in  $A$ .

(ii) Let  $m$  be regular. As (i) holds for any cardinal  $m$  we show that  $x$  weak  $m$ -accessible in  $A$  implies  $x$   $m$ -accessible in  $A$ . There exists  $X \subseteq A$  such that  $x = \bigvee_A X$  and for each  $Y \subseteq X$  with  $|Y| < m$ ,  $\bigvee_A Y < x$ . Define:

$$X^* = \{\bigvee_A Y; Y \subseteq X \text{ and } |Y| < m\}.$$

Then  $X^*$  is  $m$ -directed by Lemma 1.7 and  $\bigvee_A X^* = \bigvee_A X$ . Evidently  $x \notin X^*$  and thus  $x$  is  $m$ -accessible in  $A$ .

(iii) Let  $x$  be  $m$ -accessible in  $L$  via  $u[L]$ . Then there exists  $m$ -directed  $X \subseteq u[L]$  such that  $x = \bigvee_L X \notin X$ . Let  $Y \subseteq X$  with  $|Y| < m$ . Then there exists  $w \in X$  such that for each  $y \in Y$ ,  $y \leq w$ . Hence  $\bigvee_{u[L]} Y \leq w$  and  $w < \bigvee_L X = x$  yielding  $\bigvee_{u[L]} Y < x$  as required.



(iv) Let  $m$  be regular. As (iii) holds for cardinal  $m$  we show that  $x$  weak  $m$ -accessible in  $L$  via  $u[L]$  implies  $x$   $m$ -accessible in  $L$  via  $u[L]$ . There exists  $X \subseteq u[L]$  such that  $x = \bigvee_L X$  and for each  $Y \subseteq X$  with  $|Y| < m$ ,  $\bigvee_{u[L]} Y < x$ . Define

$$X^* = \left\{ \bigvee_{u[L]} Y; Y \subseteq X \text{ and } |Y| < m \right\}.$$

Then  $X^*$  is evidently  $m$ -directed and  $\bigvee_L X^* \leq x$ . However we then have:

$$x = \bigvee_L X = \bigvee_L \left\{ \bigvee_L Y; Y \subseteq X \text{ and } |Y| < m \right\} \leq \bigvee_L X^* \leq x$$

and so  $\bigvee_L X^* = x$ . Evidently  $x \notin X^*$  and thus  $x$  is  $m$ -accessible in  $L$  via  $u[L]$ .

### THEOREM 2.16.

*Let  $L$  be a complete lattice and  $u : L \rightarrow L$  a closure operator. The following conditions are equivalent:*

- i.  $u$  preserves  $m$ -compactness.*
- ii. For each  $x \in L$ ,  $x$   $m$ -compact in  $L$  implies  $x$   $m$ -compact in  $u[L]$ .*
- iii. For each  $x \in L$ ,  $C(m, x, L) \subseteq C(m, x, u[L])$ .*
- iv. For each  $x \in L$ ,  $x$  weak  $m$ -accessible in  $L$  implies that  $C(m, u(x), L) \subseteq C(m, u(x), u[L])$ .*
- v. For each  $x \in L$ ,  $x$  weak  $m$ -accessible in  $u[L]$  implies that  $C(m, x, L) \subseteq C(m, x, u[L])$ .*

### PROOF

(i)  $\Leftrightarrow$  (ii): Follows directly from Lemma 2.6.

(i)  $\Rightarrow$  (iii): Let  $y \in C(m, x, L)$ . Then  $y \leq x$  and  $y$  is  $m$ -compact in  $L$ . Hence  $u(y)$  is  $m$ -compact in  $u[L]$  and by Lemma 2.6,  $y$  is  $m$ -compact in  $u[L]$  and so  $y \in$

$C(m, x, u[L])$ .

(iii)  $\Rightarrow$  (iv): Evident.

(iv)  $\Rightarrow$  (v): Let  $x$  be weak  $m$ -accessible in  $u[L]$ . Then  $x = \bigvee_{u[L]} X$  where  $X \subseteq u[L]$  and for each  $Y \subseteq X$  with  $|Y| < m$ ,  $\bigvee_{u[L]} Y < x$ . Consider  $w = \bigvee_L X$ . Let  $Y \subseteq X$  with  $|Y| < m$ . Then  $\bigvee_L Y \leq w$ . If  $\bigvee_L Y = w$  then  $u(w) = \bigvee_{u[L]} Y = \bigvee_{u[L]} X = x$  which contradicts the choice of  $X$ . Hence  $\bigvee_L Y < w$  and so  $w$  is weak  $m$ -accessible in  $L$ . By (iv) we have  $C(m, u(w), L) \subseteq C(m, u(w), u[L])$  and as  $u(w) = x$  we have proved (v).

(v)  $\Rightarrow$  (i): Let  $x$  be  $m$ -compact in  $L$ . Suppose  $u(x) \leq \bigvee_{u[L]} X$  where  $X \subseteq u[L]$ . We show that for some  $Y \subseteq X$  with  $|Y| < m$ ,  $u(x) \leq \bigvee_{u[L]} Y$ . Suppose that this is not so. Then  $\bigvee_{u[L]} X$  is weak  $m$ -accessible in  $u[L]$ . Hence  $C(m, \bigvee_{u[L]} X, L) \subseteq C(m, \bigvee_{u[L]} X, u[L])$  and so  $x \leq u(x) \leq \bigvee_{u[L]} X$  we see that  $x$  is  $m$ -compact in  $u[L]$  and so by Lemma 2.6,  $u(x)$  is  $m$ -compact in  $u[L]$ .

### THEOREM 2.17.

*Let  $L$  be a complete lattice,  $u : L \rightarrow L$  a closure operator and  $m$  an infinite cardinal.*

- i. If  $u$  preserves  $m$ -compactness then for every  $x \in L$ ,  $x$  weak  $m$ -accessible in  $L$  via  $u[L]$  we have  $C(m, x, L) = C(m, u(x), L)$ .*
- ii. If  $m$  is regular and for every  $x \in L$ ,  $x$  weak  $m$ -accessible in  $L$  via  $u[L]$  we have  $C(m, x, L) = C(m, u(x), L)$ , then  $u$  preserves  $m$ -compactness.*

### PROOF

(i) Evidently  $C(m, x, L) \subseteq C(m, u(x), L)$ . For the converse let  $y \in C(m, u(x), L)$ . Then  $y$  is  $m$ -compact in  $L$  and  $y \leq u(x)$  where for some  $X \subseteq u[L]$ ,  $x = \bigvee_L X$  and for each  $Y \subseteq X$  with  $|Y| < m$  we have  $\bigvee_{u[L]} Y < x$ . Thus  $u(y) \leq u(x) = \bigvee_{u[L]} X$  and as

$u(y)$  is  $m$ -compact in  $u[L]$  there exists  $Y \subseteq X$  with  $|Y| < m$  such that  $u(y) \leq \bigvee_{u[L]} Y$ .

But then  $y \leq u(y) < x$  and so  $y \in C(m, x, L)$  as required.

(ii) Let  $x$  be  $m$ -compact in  $L$  and suppose  $u(x) \leq \bigvee_{u[L]} X$  where  $X \subseteq u[L]$ . Define

$$X^* = \left\{ \bigvee_{u[L]} Y; Y \subseteq X \text{ and } |Y| < m \right\}.$$

Then for each  $Y \subseteq X$  with  $|Y| < m$  we have

$$\bigvee_{u[L]} Y \leq \bigvee_L X^*.$$

Case 1: There exists  $Y \subseteq X$  with  $|Y| < m$  such that  $\bigvee_{u[L]} Y = \bigvee_L X^*$ . Then

$$\bigvee_L X \leq \bigvee_L X^* = \bigvee_{u[L]} Y$$

and thus

$$u\left(\bigvee_L X\right) \leq u\left(\bigvee_L X^*\right) = u\left(\bigvee_{u[L]} Y\right),$$

and hence,

$$\bigvee_{u[L]} X \leq \bigvee_{u[L]} X^* = \bigvee_{u[L]} Y \leq \bigvee_{u[L]} X.$$

Thus  $u(x) \leq \bigvee_{u[L]} Y$ .

Case 2: For each  $Y \subseteq X$  with  $|Y| < m$  we have  $\bigvee_{u[L]} Y < \bigvee_L X^*$ . Then  $\bigvee_L X^*$  is weak  $m$ -accessible in  $L$  via  $u[L]$ : As  $X^* \subseteq u[L]$  we need to show that for  $Z \subseteq X^*$ ,  $|Z| < m$ ,  $\bigvee_{u[L]} Z < \bigvee_L X^*$ . But for any  $w \in Z$ , there exists  $Y_w \subseteq X$ ,  $|Y_w| < m$  such that  $w = \bigvee_{u[L]} Y_w$ . Thus

$$\bigvee_{u[L]} Z = \bigvee_{u[L]} \left\{ \bigvee_{u[L]} Y_w; w \in Z \right\} = \bigvee_{u[L]} \left( \bigcup_{w \in Z} Y_w \right).$$

Now  $\bigcup_{w \in Z} Y_w \subseteq X$  and as  $m$  is regular,  $|\bigcup_{w \in Z} Y_w| < m$ . Thus  $\bigvee_{u[L]} Z \in X^*$  and so  $\bigvee_{u[L]} Z < \bigvee_L X^*$  by the assumption leading Case 2. So  $\bigvee_L X^*$  is indeed weak  $m$ -accessible in  $L$  via  $u[L]$ . Thus  $C(m, \bigvee_L X^*, L) = C(m, u(\bigvee_L X^*), L)$ . Further

$$u(\bigvee_L X^*) = \bigvee_{u[L]} X^* = \bigvee_{u[L]} X.$$

As  $x$  is  $m$ -compact in  $L$  and

$$x \leq u(x) \leq \bigvee_{u[L]} X = u(\bigvee_L X^*)$$

we conclude that  $x \leq \bigvee_L X^*$ . Then the  $m$ -compactness of  $x$  implies the existence of  $Z \subseteq X^*$  with  $|Z| < m$  such that  $x \leq \bigvee_L Z$ . Further for each  $w \in Z$  there exists  $Y_w \subseteq X$  with  $|Y_w| < m$  such that  $w = \bigvee_{u[L]} Y_w$ . Hence

$$x \leq \bigvee_L Z = \bigvee_L \{ \bigvee_{u[L]} Y_w; w \in Z \}$$

and so

$$u(x) \leq \bigvee_{u[L]} \{ \bigvee_{u[L]} Y_w; w \in Z \} = \bigvee_{u[L]} (\bigcup_{w \in Z} Y_w).$$

As  $|\bigcup_{w \in Z} Y_w| < m$  by the regularity of  $m$  we have shown in either case that  $u(x)$  is  $m$ -compact in  $u[L]$ .

REMARK 2.18.

Lemma 2.15 and Theorem 2.16 yield that for the case where  $m$  is regular, Theorem 2.16 reduces to 2.7.3 parts (i) to (v). Considering parts (iii) and (iv) of Lemma 2.15 in the case of  $m$  regular Theorem 2.17 reduces to the equivalence of parts (i) and (vi) of 2.7.3. This of course yields a proof of Theorem 2.17 part (ii) but the given proof eliminates the use of the concept of weak  $m$ -compactness and so makes this chapter somewhat more self-contained. The proof given for Theorem 2.17 part(ii)

seems to rely on the regularity of  $m$ . At this stage it is not known whether or not the regularity of  $m$  may be dropped as a condition of Theorem 2.17 part(ii).

We now turn to the analogues of 2.7.4 and 2.7.5.

THEOREM 2.19.

*Let  $L$  be a complete lattice such that  $1_L$  is not weak  $m$ -accessible and  $y \in L$ . Then  $y$  is  $m$ -compact in  $L$  if and only if for any closure operator  $u : L \rightarrow L$ , whenever  $y \leq x$  where  $x = \bigvee_L X$  and for each  $Y \subseteq X$ ,  $|Y| < m$ ,  $\bigvee_{u[L]} u[Y] \leq \bigvee_L u[X]$ , then  $u(y) \leq \bigvee_L u[X]$ .*

PROOF

( $\Rightarrow$ ): If  $y$  is  $m$ -compact then  $y \leq x$  implies there exists  $Y \subseteq X$ ,  $|Y| < m$  such that  $y \leq \bigvee_L Y$ . Thus

$$u(y) \leq \bigvee_{u[L]} u[Y] \leq \bigvee_L u[X]$$

as required.

( $\Leftarrow$ ): Conversely, suppose  $y$  is not  $m$ -compact in  $L$ . Then there exists  $x \in L$  such that  $y \leq x$  where  $x = \bigvee_L X$  but for no  $Y \subseteq X$  with  $|Y| < m$  do we have  $y \leq \bigvee_L Y$ . Thus for each  $Y \subseteq X$  with  $|Y| < m$  we have  $\bigvee_L Y < \bigvee_L X$  and thus  $x$  is weak  $m$ -accessible in  $L$ . Hence  $x < 1_L$ . Define  $u : L \rightarrow L$  by setting for each  $z \in L$ :

$$u(z) = \begin{cases} z, & \text{if } z \leq \bigvee_L Y \text{ for some } Y \subseteq X, |Y| < m \\ 1_L, & \text{otherwise} \end{cases}$$

Then  $u$  is a closure operator (see Diagram 2.4). Also for each  $Y \subseteq X$ ,  $|Y| < m$

$$u\left(\bigvee_L Y\right) = \bigvee_{u[L]} u[Y] = \bigvee_L Y$$

and thus

$$\bigvee_{u[L]} u[Y] \leq \bigvee_L u[X] = \bigvee_L X.$$

But  $u(y) = 1_L$  and so  $u(y) \not\leq \bigvee_L u[X] = \bigvee_L X$ .

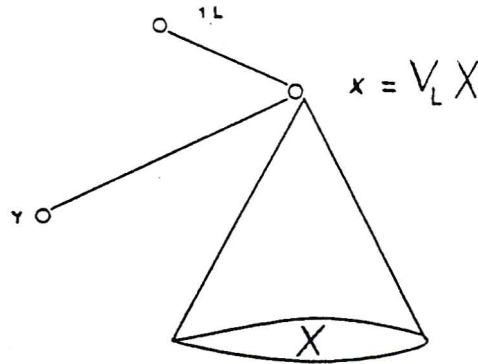

DIAGRAM 2.4.

REMARK 2.20.

By Lemma 2.15(iii), Theorem 2.17(i) implies the following result:

*Let  $m$  be a singular cardinal and  $u : L \rightarrow L$  a closure operator. If  $u$  preserves the  $m$ -compactness of  $L$ , then for all  $x \in L$ ,  $x$   $m$ -accessible in  $L$  via  $u[L] \Rightarrow C(m, x, L) = C(m, u(x), L)$ .*

The following theorem is the analogue of 2.7.5.

THEOREM 2.21.

*Let  $L$  be a complete lattice and  $m$  an infinite cardinal. If every closure operator  $u : L \rightarrow L$  preserves  $m$ -compactness then for every  $x, y \in L$ ,  $x \leq y$  and  $x$  weak  $m$ -accessible in  $L$  we have  $C(m, x, L) = C(m, y, L)$ . Further, if  $m$  is regular the converse holds.*

PROOF

( $\Rightarrow$ ): Let  $m$  be any infinite cardinal. Suppose to the contrary that there exist  $x, y \in L$ ,  $x \leq y$ ,  $x$  weak  $m$ -accessible in  $L$  and  $C(m, x, L) \subset C(m, y, L)$ . Then there exists  $X \subseteq L$  such that  $x = \bigvee_L X$  and for each  $Y \subseteq X$ ,  $|Y| < m$ ,  $\bigvee_L Y < x$ . Define  $u : L \rightarrow L$  by setting for each  $z \in L$ :

$$u(z) = \begin{cases} z, & \text{if } z < x \\ z \vee y, & \text{otherwise} \end{cases}$$

Then  $u : L \rightarrow L$  is readily seen to be a closure operator on  $L$ . Further  $X \subseteq u[L]$  and for each  $Y \subseteq X$  with  $|Y| < m$  we have  $u(\bigvee_L Y) = \bigvee_L Y$  i.e.  $\bigvee_L Y = \bigvee_{u[L]} Y$ . Consequently  $x$  is weak  $m$ -accessible in  $L$  via  $u[L]$ . However  $u(x) = y$  and  $C(m, x, L) \subset C(m, u(x), L)$ . By Theorem 2.17(i),  $u$  does not preserve  $m$ -compactness. This contradicts the stated condition on  $L$ .

( $\Leftarrow$ ): Suppose now that  $m$  is regular. We show the converse using Theorem 2.17(ii). Let  $u : L \rightarrow L$  be any closure operator, and let  $x$  be weak  $m$ -accessible in  $L$  via  $u[L]$ . Then  $x$  is evidently weak  $m$ -accessible in  $L$ . As  $x \leq u(x)$  we have  $C(m, x, L) = C(m, u(x), L)$ . Consequently  $u$  preserves  $m$ -compactness.

LEMMA 2.22.

*Let  $u : L \rightarrow L$  be an  $m$ -compact preserving closure operator. Then  $u$  is  $m$ -algebraic if and only if for every  $x \in L$ , if  $x$  is  $m$ -accessible in  $L$  via  $u[L]$  and  $x < u(x)$  then  $C(m, x, L) \subset C(m, u(x), L)$ .*

PROOF

( $\Rightarrow$ ): Suppose  $u$  is  $m$ -algebraic. Let  $x$  be  $m$ -accessible in  $L$  via  $u[L]$ . Then  $x = u(x)$  and the result holds trivially.

( $\Leftarrow$ ): To show that  $u$  is  $m$ -algebraic, let  $X \subseteq u[L]$ ,  $X$   $m$ -directed. By Lemma

1.11(i) we need to show  $\bigvee_L X = u(\bigvee_L X)$ . If  $\bigvee_L X \in X$  there is nothing to prove. Hence assume  $\bigvee_L X \notin X$ . It follows that  $x = \bigvee_L X$  is  $m$ -accessible in  $L$  via  $u[L]$  and by Lemma 2.15(iii)  $x$  is weak  $m$ -accessible in  $L$  via  $u[L]$ . If  $x < u(x)$  then we have  $C(m, x, L) \subset C(m, u(x), L)$ . However this contradicts Theorem 2.17(i). So  $x = u(x)$  as required.

### THEOREM 2.23.

*Let  $m$  be an infinite cardinal and  $L$  a complete lattice. The following conditions are equivalent:*

- i. Every closure operator  $u : L \rightarrow L$  which is  $m$ -compact preserving is also  $m$ -algebraic.*
- ii. For every  $x, y \in L$ ,  $x$   $m$ -accessible in  $L$  and  $x < y$  we have  $C(m, x, L) \subset C(m, y, L)$ .*

### PROOF

Assume (i) holds but (ii) is false. Then there exist  $x, y \in L$ ,  $x$   $m$ -accessible in  $L$  and  $x < y$  with  $C(m, x, L) = C(m, y, L)$ . Define  $u : L \rightarrow L$  by setting for each  $z \in L$ :

$$u(z) = \begin{cases} z, & \text{if } z < x \\ z \vee y, & \text{otherwise} \end{cases}$$

Then  $u$  is a closure operator. We show that  $u$  is an  $m$ -compact preserving operator: First we show that if  $Y \subseteq u[L]$  with  $\bigvee_L Y \neq x$  then  $\bigvee_L Y = \bigvee_{u[L]} Y$ . For suppose  $\bigvee_L Y < x$ . Then

$$\bigvee_L Y = u(\bigvee_L Y) = \bigvee_{u[L]} Y.$$

Otherwise  $\bigvee_L Y \not< x$ . Consequently  $x$  is not an upper bound of  $Y$  and so there exists



$z \in Y$  with  $z \not\leq x$ . As

$$u[L] = ((x)_L \setminus \{x\}) \cup (y)_L$$

it follows that  $y \leq z \leq \bigvee_L Y$ . So

$$\bigvee_{u[L]} Y = u(\bigvee_L Y) = (\bigvee_L Y) \vee y = \bigvee_L Y.$$

Now let  $c \in C_m(L)$ ,  $Z \subseteq u[L]$  such that  $u(c) \leq \bigvee_{u[L]} Z$ . We show that there exists  $T \subseteq Z$ ,  $|T| < m$  such that  $u(c) \leq \bigvee_{u[L]} T$ . If  $\bigvee_L Z \neq x$  then  $\bigvee_L Z = \bigvee_{u[L]} Z$  and so

$$c \leq u(c) \leq \bigvee_{u[L]} Z = \bigvee_L Z.$$

As  $c \in C_m(L)$  there exists  $T \subseteq Z$  with  $|T| < m$  such that  $c \leq \bigvee_L T$ . Consequently  $u(c) \leq \bigvee_{u[L]} T$ . The other possibility is that  $\bigvee_L Z = x$ . Then  $u(x) = \bigvee_{u[L]} Z = y$ . Since  $c \leq u(c) \leq y$  and  $C(m, x, L) = C(m, y, L)$  we have  $c \leq x = \bigvee_L Z$ . Thus there exists  $T \subseteq Z$ ,  $|T| < m$  such that  $c \leq \bigvee_L T$ . Hence  $u(c) \leq \bigvee_{u[L]} T$ .

Further  $u$  is not  $m$ -algebraic as there exists  $m$ -directed  $X \subseteq L$  such that  $x = \bigvee_L X \notin X$ . But  $u(x) = y \neq x$ . By definition of  $u$ ,  $X \subseteq u[L]$  and so

$$\bigvee_L X \neq u(\bigvee_L X) = \bigvee_{u[L]} X.$$

So  $u$  is an  $m$ -compact preserving closure operator which is not  $m$ -algebraic. This contradiction shows (i) only if (ii).

Assume now that (ii) holds. Let  $u : L \rightarrow L$  be an  $m$ -compact preserving closure operator. Let  $X \subseteq u[L]$  be  $m$ -directed. By Lemma 1.11(i), we need to show  $x = \bigvee_L X = u(\bigvee_L X)$ . If  $x \in X$  this is trivial. Suppose  $x \notin X$ . Then  $x$  is  $m$ -accessible in  $L$  (via  $u[L]$ ) and hence weak  $m$ -accessible in  $L$  via  $u[L]$  by Lemma 2.15(iii). If  $x < u(x)$  then  $C(m, x, L) \subset C(m, u(x), L)$ . But  $u$  is  $m$ -compact preserving and so this contradicts Theorem 2.17(i). Consequently we must have  $x = u(x)$  as required.

REMARK 2.24.

We now turn to the study of the set  $C(m, x, L)$ .

LEMMA 2.25.

Let  $L$  be a complete lattice,  $m$  an infinite cardinal and  $x \in L$ . Then:

- i.  $C(m, x, L)$  is  $\text{cf}(m)$ -directed.
- ii. Let  $m$  be regular and  $x$  be  $m$ -inaccessible in  $L$ . Then  $x$  is  $m$ -compact if and only if  $x = \bigvee_L C(m, x, L)$ .

PROOF

(i) Let  $Y \subseteq C(m, x, L)$ ,  $|Y| < \text{cf}(m)$ . We show  $\bigvee_L Y \in C(m, x, L)$  also. So suppose  $\bigvee_L Y \leq \bigvee_L X$  where  $X \subseteq L$ . Then for each  $y \in Y$  there exists  $X_y \subseteq X$  with  $|X_y| < m$  such that  $y \leq \bigvee_L X_y$ . Consequently

$$\bigvee_L Y \leq \bigvee_L \left\{ \bigvee_L X_y; y \in Y \right\} = \bigvee_L \left( \bigcup_{y \in Y} X_y \right)$$

Further  $|\bigcup_{y \in Y} X_y| < m$  as required.

(ii) If  $x$  is  $m$ -compact then  $x \in C(m, x, L)$  and so  $x = \bigvee_L C(m, x, L)$ . Conversely, suppose  $x = \bigvee_L C(m, x, L)$ . As  $m$  is regular  $C(m, x, L)$  is  $m$ -directed. As  $x$  is  $m$ -inaccessible, we must have  $x \in C(m, x, L)$ , i.e.  $x$  is  $m$ -compact in  $L$ .

DEFINITION 2.26.

Let  $L$  be a complete lattice. Then  $L$  is an  $m$ -algebraic lattice if for every  $x \in L$ ,  $x = \bigvee_L C(m, x, L)$ .

COROLLARY 2.27.

Let  $L$  be an  $m$ -algebraic lattice.

- i. Every  $m$ -compact preserving closure operator is  $m$ -algebraic.
- ii. If  $m$  is regular, every  $m$ -algebraic closure operator is  $m$ -compact preserving.

PROOF

(i) follows from Theorem 2.23 as  $x < y$  implies  $\bigvee_L C(m, x, L) < \bigvee_L C(m, y, L)$  and consequently  $C(m, x, L) \subset C(m, y, L)$ .

(ii) This holds generally by Theorem 2.8.

DEFINITION 2.28.

Let  $u : L \rightarrow L$  be a closure operator on a complete lattice  $L$ . Then  $u$  reflects  $m$ -compactness if for each  $x \in u[L]$ ,  $x$   $m$ -compact in  $u[L]$ , there exists  $y \in C_m(L)$  such that  $u(y) = x$ .

THEOREM 2.29.

Let  $L$  be a complete lattice,  $m$  an infinite cardinal and  $u : L \rightarrow L$  a closure operator. If  $u$  reflects  $m$ -compactness then for each  $x \in u[L] \cap C_m(u[L])$ ,  $x = u(\bigvee_L C(m, x, L))$ . If  $m$  is regular the converse holds.

PROOF

Suppose  $u$  reflects  $m$ -compactness. As  $x \in C_m(u[L]) \subseteq u[C_m(L)]$  there exists  $z \in C_m(L)$  such that  $u(z) = x$ . But  $z \leq x$  and so  $z \leq \bigvee_L C(m, x, L) \leq x$ . Thus  $x = u(\bigvee_L C(m, x, L))$  as required.

Suppose now that  $m$  is regular. We show the converse. Let  $x \in u[L]$ ,  $x \in C_m(u[L])$ . Then

$$x = u\left(\bigvee_L C(m, x, L)\right) = \bigvee_{u[L]} u[C(m, x, L)].$$

As  $x \in C_m(u[L])$  there exists  $Y \subseteq u[C(m, x, L)]$  such that  $|Y| < m$  and  $x \leq \bigvee_{u[L]} Y$ . For each  $y \in Y$  there exists  $z_y \in C(m, x, L)$  such that  $y = u(z_y)$ . Further  $|\{z_y; y \in Y\}| \leq |Y| < m$  and as  $m$  is regular  $C(m, x, L)$  is  $m$ -directed which implies that there exists  $z \in C(m, x, L)$  such that for each  $y \in Y$ ,  $y \leq z_y \leq z$ . Thus

$$u(x) = x \leq \bigvee_{u[L]} Y \leq \bigvee_{u[L]} \{u(z_y); y \in Y\} \leq u(z) \leq u(x).$$

Consequently  $x = u(z)$  as required.

### THEOREM 2.30.

*Let  $m, n$  be infinite cardinals where  $m \leq n$  and  $n$  is regular. Then every closure operator  $u : L \rightarrow L$ , where  $L$  is an  $m$ -algebraic lattice, reflects  $n$ -compactness.*

### PROOF

For any  $x \in u[L]$ ,  $x = \bigvee_L C(m, x, L)$ . Further  $C(m, x, L) \subseteq C(n, x, L) \subseteq (x)_L$ . Thus  $x = \bigvee_L C(n, x, L)$ . Consequently  $x = u(x) = u(\bigvee_L C(n, x, L))$ . As  $n$  is regular, Theorem 2.29 yields the result.

### THEOREM 2.31.

*Let  $m$  be a regular infinite cardinal and  $L$  a complete lattice. The following conditions are equivalent:*

- i.  $L$  is an  $m$ -algebraic lattice.*
- ii. Every closure operator is  $m$ -compact reflecting.*

- 
- iii. *Every  $m$ -compact preserving closure operator is  $m$ -compact reflecting.*
- iv. *Every  $m$ -algebraic closure operator is  $m$ -compact reflecting.*

PROOF

(i)  $\Rightarrow$  (ii) Follows from Theorem 2.30.

(ii)  $\Rightarrow$  (iii) Trivial.

(iii)  $\Rightarrow$  (iv) Follows from Corollary 2.27(i)

(iv)  $\Rightarrow$  (i) Analogous to the proof of Theorem 1.54.

## CHAPTER 3

In Chapter 1 the significance of weak  $m$ -algebraic lattices in the study of closure operators is shown. Weak  $m$ -algebraic lattices may be characterised as those lattices for which every closure operator is weak  $m$ -compact reflecting. On a weak  $m$ -algebraic lattice the concepts of  $m$ -algebraic closure operator and weak  $m$ -compact preserving closure operator coincide. This does not however characterise weak  $m$ -algebraic lattices. This chapter explores weak  $m$ -Tulipani closure operators. It is shown that these operators are weak  $m$ -compact preserving and that weak  $m$ -algebraic lattices are precisely those complete lattices on which the weak  $m$ -Tulipani and  $m$ -algebraic closure operators coincide.

THEOREM 3.1.

*Let  $L$  be a weak  $m$ -algebraic lattice and  $u : L \rightarrow L$  a closure operator. The following conditions are equivalent:*

- i.  $u$  is  $m$ -algebraic.*
- ii.  $u$  is weak  $m$ -compact preserving.*
- iii. For each  $x \in L$ ,  $W(m, \bigvee_L u[W(m, x, L)], L) = W(m, u(x), L)$ .*

PROOF

The equivalence of (i) and (ii) is Corollary 1.48. Thus assume  $u$  is  $m$ -algebraic (and so also weak  $m$ -compact preserving). As  $L$  is weak  $m$ -algebraic,  $x = \bigvee_L W(m, x, L)$  and so  $u(x) = \bigvee_L u[W(m, x, L)]$ . (This follows as  $W(m, x, L)$  is  $m$ -directed by Lemma 1.45.) Consequently  $W(m, u(x), L) = W(m, \bigvee_L u[W(m, x, L)], L)$  as required.

Conversely, suppose (iii) holds. We show that  $u$  is weak  $m$ -compact preserving.

Let  $w \in W_m(L)$  and suppose  $u(w) \leq \bigvee_{u[L]} X$  where  $X \subseteq u[L]$  and  $X$  is  $m$ -directed.

Now  $\bigvee_{u[L]} X = u(\bigvee_L X)$  and so

$$w \leq u(w) \leq u\left(\bigvee_L X\right).$$

Thus by (iii) we have  $w \in W(m, \bigvee_L u[W(m, \bigvee_L X, L)], L)$ . Hence  $w \leq \bigvee_L u[W(m, \bigvee_L X, L)]$

and so as  $w$  is weak  $m$ -compact,  $w \leq u(z)$  where  $z \leq \bigvee_L X$ ,  $z \in W_m(L)$ . Consequently for some  $x \in X$ ,  $z \leq x$ . It follows that

$$u(w) \leq u(u(z)) = u(z) \leq u(x) = x,$$

and so it has been shown that  $u$  is weak  $m$ -compact preserving.

### DEFINITION 3.2.

Let  $L$  be a complete lattice and  $u : L \rightarrow L$  a closure operator. Then  $u$  is a *weak  $m$ -Tulipani closure operator* if for each  $x \in L$ ,  $W(m, \bigvee_L u[W(m, x, L)], L) = W(m, u(x), L)$ .

### LEMMA 3.3.

*Let  $L$  be a complete lattice and  $u : L \rightarrow L$  a closure operator. The following conditions are equivalent:*

- i.  $u$  is weak  $m$ -Tulipani.*
- ii. For every  $x \in W_m(L)$ , and for every  $y \in L$ , if  $x \leq u(y)$  then there exists  $z \in W(m, y, L)$  such that  $x \leq u(z)$ .*

### PROOF

(i)  $\Rightarrow$  (ii): Let  $x \in W_m(L)$  and  $y \in L$  such that  $x \leq u(y)$ . Then  $x \leq \bigvee_L u[W(m, y, L)]$ . Consequently, there exists  $z \in W(m, y, L)$  such that  $x \leq u(z)$

as required.

(ii)  $\Rightarrow$  (i): Evidently  $W(m, \bigvee_L u[W(m, x, L)], L) \subseteq W(m, u(x), L)$ . Conversely, let  $y \in W(m, u(x), L)$ . Then  $y \leq u(x)$ . Hence there exists  $z \in W(m, x, L)$  such that

$$y \leq u(z) \leq \bigvee_L u[W(m, x, L)].$$

Hence  $y \in W(m, \bigvee_L u[W(m, x, L)], L)$ .

#### REMARK 3.4.

Theorem 3.1 has a converse which completes the discussion of the example in Remark 1.49. We show later in this chapter that the following result holds:

*Let  $L$  be a complete lattice and  $m$  an infinite cardinal. Then  $L$  is a weak  $m$ -algebraic lattice if and only if for each closure operator  $u : L \rightarrow L$  the following conditions are equivalent:*

- i.  $u$  is  $m$ -algebraic.*
- ii.  $u$  is weak  $m$ -compact preserving.*
- iii.  $u$  is weak  $m$ -Tulipani.*

In order to present this proof we first analyse weak  $m$ -Tulipani operators a little further.

#### THEOREM 3.5.

*Let  $L$  be a complete lattice and  $u : L \rightarrow L$  a weak  $m$ -Tulipani closure operator. Then  $u : L \rightarrow L$  preserves weak  $m$ -compactness.*

#### PROOF

This follows the same proof as given for Theorem 3.1, (iii)  $\Rightarrow$  (i). (Notice that the weak  $m$ -algebraicity of lattice  $L$  is not used in this part of the proof.)



REMARK 3.6.

Theorem 3.5 shows that weak  $m$ -Tulipani closure operators, just like  $m$ -algebraic closure operators, preserve weak  $m$ -compactness. In fact an  $m$ -algebraic closure operator preserves weak  $n$ -compactness for  $m \leq \bar{n}$ . (Theorem 1.31). We now show that this aspect of  $m$ -algebraic closure operators is quite different in the case of weak  $m$ -Tulipani closure operators.

EXAMPLE 3.7.

Let  $\alpha \geq 1$  be an ordinal number such that  $\omega_\alpha$  is regular. Let  $[-2, -1]$  be the interval in the set of all real numbers ordered as usual and let  $a \notin \omega_\alpha \cup [-2, -1]$ . Consider the diagram below:

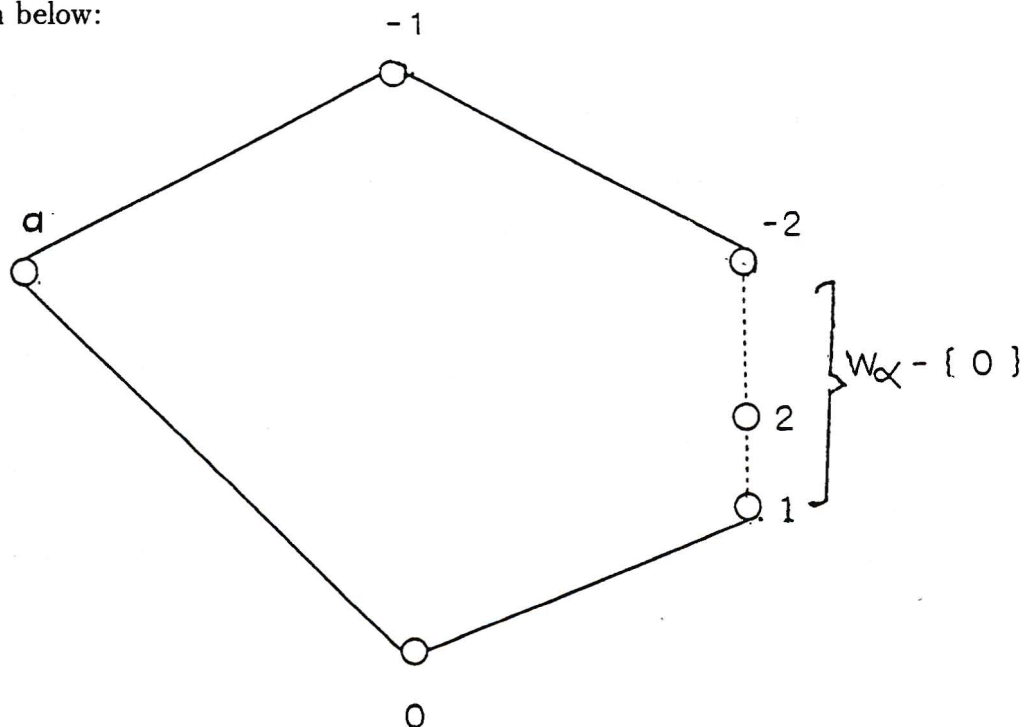

DIAGRAM 3.1.

Define  $u : L \rightarrow L$  as follows

$$u(x) = \begin{cases} -1, & \text{if } x \in [-2, -1] \\ x, & \text{otherwise} \end{cases}$$

Then  $L$  is a complete lattice and  $u$  is a closure operator on  $L$ . Now,  $x \in L$  is  $\omega$ -compact in  $L$  iff  $x \in \omega_\alpha$  and either  $x = 0$  or  $y \prec x$  for some  $y \in \omega_\alpha$ . Also  $a$  is  $\omega_1$ -compact in  $L$ .

From the characterisation of  $\omega$ -compact elements in  $L$  and from the definition of  $u$ , it follows that  $u$  is weak  $\omega$ -Tulipani. It is easily verified that:

$$u[L] = \omega_\alpha \cup \{a, 1_L\}.$$

Since  $\omega_\alpha$  is regular,  $a = u(a)$  must be  $\omega_{\alpha \oplus 1}$ -compact in  $u[L]$ , but it is not  $m$ -compact for any cardinal  $m \leq \omega_\alpha$ . We have supposed that  $\alpha \geq 1$  and hence  $\omega_1 < \omega_{\alpha \oplus 1}$  which shows that  $u$  does not preserve weak  $\omega_1$ -compactness.

### EXAMPLE 3.8.

In this example it shall be shown that there exists closure operator  $u : L \rightarrow L$  such that  $u$  is  $\omega$ -compact preserving but  $u$  is neither  $\omega$ -algebraic nor an weak  $\omega$ -Tulipani type one. Consider the lattice  $\langle L, \leq \rangle$  represented in Diagram 3.2 that follows.

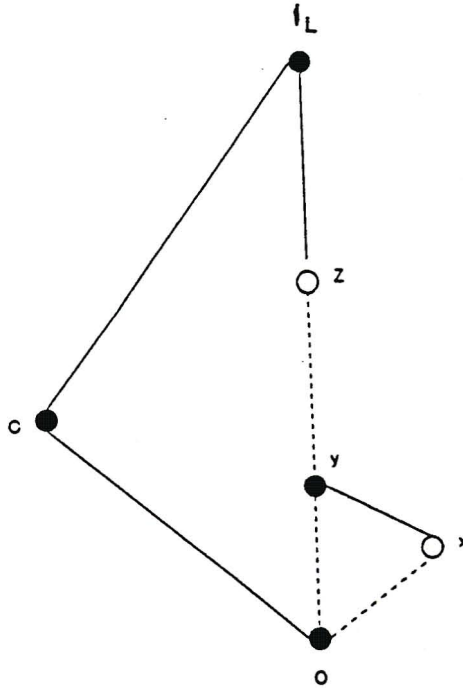

DIAGRAM 3.2

The intervals  $[0, x]$ ,  $[0, y]$ ,  $[y, z]$  are isomorphic to the naturally ordered interval  $[0, 1]$ ; if  $\prec$  is the relation of covering in  $L$ , then  $0 \prec c \prec 1_L$ ,  $x \prec y$ ,  $z \prec 1_L$ . For all  $s \in L$  let  $u$  be defined as follows:

$$u(s) = \begin{cases} y, & \text{if } s = x \\ 1_L, & \text{if } s \in (y, z] \\ s, & \text{otherwise} \end{cases}$$

Obviously,  $u$  is a closure operator on the complete lattice  $L$ .

$\langle u[L], \leq \rangle$  is described by Diagram 3.3 which follows hereafter.

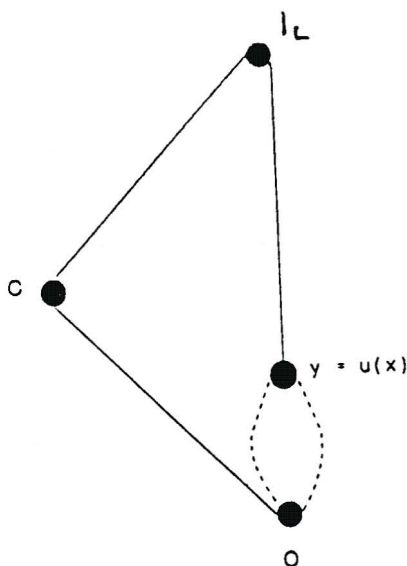

DIAGRAM 3.3

Moreover,  $C_\omega(L) = \{0, c, 1_L\} = C_\omega(u[L])$ . Therefore,  $u$  is  $\omega$ -compact preserving. But,  $u$  is not  $\omega$ -algebraic since  $[0, x)$  is  $\omega$ -directed and

$$\bigvee_L [0, x) = x \prec y = \bigvee_{u[L]} [0, x).$$

$u$  is also not weak  $\omega$ -Tulipani since  $c < 1_L = u(z)$ , and  $C_\omega(z) = \{0\}$ ,  $c \not\leq u(0) = 0$ .

REMARK 3.9.

We turn to the characterisation of lattices on which every closure operator is weak  $m$ -Tulipani and also of lattices where weak  $m$ -Tulipani and  $m$ -algebraic operators coincide.

THEOREM 3.10.

Let  $L$  be a complete lattice and  $m$  an infinite cardinal. The following conditions are equivalent:

- i. Every closure operator  $u : L \rightarrow L$  is weak  $m$ -Tulipani.
- ii. For every  $x, y \in L$ ,  $x \in W_m(L)$  and  $y \notin W_m(L)$ , we have  $x \leq y$ .
- iii.  $L = (\bigvee_L W_m(L))_L \cup (\bigvee_L W_m(L))_L$  and  $(\bigvee_L W_m(L)) \setminus \{\bigvee_L W_m(L)\} \subseteq W_m(L)$ .

PROOF

(i)  $\Rightarrow$  (ii): Suppose (ii) does not hold. Then there exist  $x, y \in L$ ,  $x \in W_m(L)$ ,  $y \notin W_m(L)$  with  $x \not\leq y$ . Define  $u : L \rightarrow L$  by setting for each  $z \in L$ :

$$u(z) = \begin{cases} z, & \text{if } z < y \\ 1_L, & \text{otherwise} \end{cases}$$

Then  $u$  is evidently a closure operator. Further, if  $z \in W(m, y, L)$  then  $z < y$  and so  $u(z) = z$ . Hence  $W(m, \bigvee_L u[W(m, y, L)], L) = W(m, y, L)$  and  $x \notin W(m, y, L)$ . However as  $u(y) = 1_L$  we have  $x \in W(m, u(y), L)$ . It follows that  $u$  is not weak  $m$ -Tulipani.

(ii)  $\Rightarrow$  (i): Let  $u : L \rightarrow L$  be a closure operator. Suppose  $y \in W(m, u(x), L)$ . Then  $y \leq u(x)$ . If  $x \notin W_m(L)$  then we must have  $y \leq x$  and so  $y \in W(m, x, L)$  which implies  $y \in W(m, \bigvee_L u[W(m, x, L)], L)$  as required. If  $x \in W_m(L)$  then  $x$  is

the greatest element of  $W(m, x, L)$ , and  $u(x) = \bigvee_L u[W(m, x, L)]$ . Again we have  $W(m, \bigvee_L u[W(m, x, L)], L) = W(m, u(x), L)$  as required.

(ii)  $\Leftrightarrow$  (iii): Suppose (ii) holds. If  $x \in L$  then either  $x \in W_m(L)$  or  $x \notin W_m(L)$ . In the former case  $x \leq \bigvee_L W_m(L)$ . In the latter case we have for each  $y \in W_m(L)$ ,  $y \leq x$  and so  $\bigvee_L W_m(L) \leq x$ . Thus  $L = (\bigvee_L W_m(L))_L \cup [\bigvee_L W_m(L)]_L$ . Now let  $y < \bigvee_L W_m(L)$ . If  $y \notin W_m(L)$  then by (ii) we conclude  $\bigvee_L W_m(L) \leq y$  which is impossible. Hence  $y \in W_m(L)$ .

Conversely suppose (iii) holds. Take  $x, y \in L$  with  $x \in W_m(L)$  and  $y \notin W_m(L)$ . Then  $x \leq \bigvee_L W_m(L)$  and also  $y \geq \bigvee_L W_m(L)$ . So  $x \leq y$  as required.

### THEOREM 3.11.

*Let  $L$  be a complete lattice and  $m$  an infinite cardinal. Then the following conditions are equivalent:*

- i. Every  $m$ -algebraic closure operator is weak  $m$ -Tulipani.*
- ii. For every  $x \in L$ ,  $\bigvee_L W(m, x, L) < x$  implies  $W(m, x, L) = W_m(L)$ .*
- iii. For every  $x, y \in L$ ,  $\bigvee_L W(m, x, L) < x$ ,  $y \in W_m(L)$  implies  $y \leq x$ .*
- iv. The complete lattice  $(\bigvee_L W_m(L))_L$  is a weak  $m$ -algebraic lattice, and  $L = (\bigvee_L W_m(L))_L \cup [\bigvee_L W_m(L)]_L$ .*

### PROOF

(i)  $\Rightarrow$  (ii): Suppose (ii) does not hold. Then there exists  $x \in L$ ,  $\bigvee_L W(m, x, L) < x$ , but  $W(m, x, L) \subset W_m(L) = W(m, 1_L, L)$ . Define  $u : L \rightarrow L$  by setting for each  $z \in L$ :

$$u(z) = \begin{cases} z, & \text{if } z \leq \bigvee_L W(m, x, L) \\ 1_L, & \text{otherwise} \end{cases}$$

Then  $u$  is evidently an  $m$ -algebraic closure operator on  $L$ . However, if  $y \in W(m, x, L)$

then  $u(y) = y$  and so  $\bigvee_L u[W(m, x, L)] = \bigvee_L W(m, x, L)$ . Further  $W(m, u(x), L) = W(m, 1_L, L)$ . As  $W(m, \bigvee_L W(m, x, L), L) = W(m, x, L) \subset W(m, 1_L, L)$  it follows that  $u$  is not weak  $m$ -Tulipani. This contradicts (i).

(ii)  $\Rightarrow$  (i): Suppose that (ii) holds and that  $u : L \rightarrow L$  is an  $m$ -algebraic closure operator. Let  $x \in L$ . If  $\bigvee_L W(m, x, L) < x$  then, by (ii),  $W(m, x, L) = W_m(L)$ . Consequently, if  $y \in W(m, u(x), L)$  then  $y \in W_m(L) = W(m, x, L)$ . Hence  $y \in W(m, \bigvee_L u[W(m, x, L)], L)$ , as required. The only other possibility is that  $\bigvee_L W(m, x, L) = x$ . Then

$$u(x) = u\left(\bigvee_L W(m, x, L)\right) = \bigvee_L u[W(m, x, L)],$$

as  $u$  is  $m$ -algebraic. Hence  $u$  is weak  $m$ -Tulipani.

(ii)  $\Leftrightarrow$  (iii): This is obvious.

(ii)  $\Rightarrow$  (iv): Let  $x \in (\bigvee_L W_m(L))_L$ . Then  $x \leq \bigvee_L W_m(L)$ . If  $\bigvee_L W(m, x, L) < x$  then by (ii)  $W(m, x, L) = W_m(L)$ . Hence  $\bigvee_L W_m(L) < x$ ! This shows  $x = \bigvee_L W(m, x, L)$  and hence  $(\bigvee_L W_m(L))_L$  is a weak  $m$ -algebraic lattice. Further take  $x \in L$ . Then either  $x = \bigvee_L W(m, x, L)$  or  $\bigvee_L W(m, x, L) < x$ . In the former case  $x \leq \bigvee_L W_m(L)$ . In the latter case, condition (ii) yields  $W(m, x, L) = W_m(L)$ . Hence  $\bigvee_L W_m(L) < x$ . So  $L = (\bigvee_L W_m(L))_L \cup [\bigvee_L W_m(L)]_L$ .

(iv)  $\Rightarrow$  (ii): Let  $x \in L$  such that  $\bigvee_L W(m, x, L) < x$ . Then  $x \not\leq \bigvee_L W_m(L)$  by (iv). Thus  $\bigvee_L W_m(L) \leq x$  and so  $W(m, x, L) = W_m(L)$ .

### THEOREM 3.12.

*Let  $L$  be a complete lattice such that  $1_L$  is  $m$ -inaccessible in  $L$  and  $m$  an infinite cardinal. Then the following conditions are equivalent:*

- i.  $L$  is weak  $m$ -algebraic.*
- ii. For every closure operator  $u : L \rightarrow L$ ,  $u$  is  $m$ -algebraic if and only if  $u$  is weak  $m$ -Tulipani.*

PROOF

(i)  $\Rightarrow$  (ii): This follows from Theorem 3.1.

(ii)  $\Rightarrow$  (i): Suppose (ii) holds. By Theorem 3.11(iv), letting  $a = \bigvee_L W_m(L)$  we have  $L = (a) \cup [a]$  and  $(a)$  is a weak  $m$ -algebraic lattice. We show  $a = 1_L$ . For suppose to the contrary that  $a < 1_L$ .

Claim: For each  $x \in (a)$ ,  $x$  is  $m$ -inaccessible in  $L$ .

Proof of the claim: Suppose to the contrary that such  $x$  is  $m$ -accessible in  $L$ . Then  $x < 1_L$ . Define  $u : L \rightarrow L$  by setting for each  $z \in L$ ,

$$u(z) = \begin{cases} z, & \text{if } z < x \\ 1_L, & \text{otherwise} \end{cases}$$

Evidently  $u$  is a closure operator on  $L$  which is not  $m$ -algebraic. However  $u$  is weak  $m$ -Tulipani: Let  $y \in L$ . If  $y < x$  then  $u(y) = y$  and also  $u[W(m, y, L)] = W(m, y, L)$ . Since  $W(m, y, L) = W(m, \bigvee_L W(m, y, L), L)$  it follows that

$$W(m, u(y), L) = W(m, \bigvee_L u[W(m, y, L)], L).$$

The other possibility is that  $y \not< x$ . Now  $y < a$  implies  $y < a \leq x$ . Hence we conclude  $a \leq y$ , i.e.  $W(m, y, L) = W_m(L)$ . So

$$a = \bigvee_L W_m(L) = \bigvee_L W(m, y, L) \leq \bigvee_L u[W(m, y, L)]$$

and so  $W(m, \bigvee_L u[W(m, y, L)], L) = W_m(L)$ . Also as  $y \not< x$  we have  $u(y) = 1_L$  and so  $W(m, u(y), L) = W_m(L)$  also. Hence  $u$  is indeed weak  $m$ -Tulipani. This contradicts (ii) and so no such  $x$  exists. The claim is proved.

Now suppose that  $(a)_L = \{a, 1_L\}$ . Then  $1_L$  is weak  $\omega$ -compact and hence weak  $m$ -compact in  $L$ . But this contradicts  $a < 1_L$ . So there exists  $x \in L$  with  $a < x < 1_L$ . As  $a < x$  we conclude that  $x \notin W_m(L)$ , and there exists  $X \subseteq L$ ,  $X$   $m$ -directed such that  $x \leq \bigvee_L X$  but for each  $y \in X$ ,  $x \not\leq y$ . Consequently  $X$  has no maximum element

and so  $\bigvee_L X$  is  $m$ -accessible in  $L$ . But  $\bigvee_L X \in [a]$  contrary to the claim. This shows that  $a < 1_L$  is false and so  $a = 1_L$ . But  $(a)_L$  is a weak  $m$ -algebraic lattice, hence  $L$  is a weak  $m$ -algebraic lattice.

**COROLLARY 3.13.**

*Let  $L$  be a complete lattice and  $m$  an infinite cardinal. Then  $L$  is a weak  $m$ -algebraic lattice if and only if for each closure operator  $u : L \rightarrow L$  the following conditions are equivalent:*

- i.  $u$  is  $m$ -algebraic.*
- ii.  $u$  is weak  $m$ -compact preserving.*
- iii.  $u$  is weak  $m$ -Tulipani.*

**PROOF**

This follows from Theorem 3.1 and Theorem 3.12.

**REMARK 3.14.**

In a similar way to the approach of Chapter 2, we can consider the situation of compact elements rather than weak compact elements in the context of Tulipani operators. Below we give the relevant definition and results without proof as the proofs are analogous to those given here.

**DEFINITION 3.15.**

Let  $L$  be a complete lattice and  $u : L \rightarrow L$  a closure operator. Then  $u$  is an  $m$ -Tulipani closure operator if for each  $x \in L$ ,

$$C(m, \bigvee_L u[C(m, x, L)], L) = C(m, u(x), L).$$



LEMMA 3.16.

Let  $L$  be a complete lattice and  $u : L \rightarrow L$  a closure operator. Then the following conditions are equivalent:

- i.  $u$  is  $m$ -Tulipani.
- ii. For every  $x \in C_m(L)$  and for every  $y \in L$ , if  $x \leq u(y)$  then there exists  $z \in C(m, y, L)$  such that  $x \leq u(z)$ .

THEOREM 3.17.

Let  $L$  be a complete lattice and  $u : L \rightarrow L$  an  $m$ -Tulipani closure operator. Then  $u$  preserves  $m$ -compactness.

THEOREM 3.18.

Let  $L$  be a complete lattice and  $m$  an infinite cardinal. The following conditions are equivalent:

- i. Every closure operator  $u : L \rightarrow L$  is  $m$ -Tulipani.
- ii. For every  $x, y \in L$ ,  $x \in C_m(L)$  and  $y \notin C_m(L)$ , we have  $x \leq y$ .
- iii.  $L = (\bigvee_L C_m(L))_L \cup (\bigvee_L C_m(L))_L$  and  $(\bigvee_L C_m(L)) \setminus \{\bigvee_L C_m(L)\} \subseteq C_m(L)$ .

THEOREM 3.19.

Let  $L$  be a complete lattice and  $m$  an infinite cardinal. Then the following conditions are equivalent:

- i. Every  $m$ -algebraic closure operator is  $m$ -Tulipani.
- ii. For every  $x \in L$ ,  $\bigvee_L C(m, x, L) < x$  implies  $C(m, x, L) = C_m(L)$ .
- iii. For every  $x, y \in L$ ,  $\bigvee_L C(m, x, L) < x$ ,  $y \in C_m(L)$  implies  $y \leq x$ .

- iv. The complete lattice  $(\bigvee_L C_m(L))_L$  is  $m$ -algebraic, and  $L = (\bigvee_L C_m(L))_L \cup [\bigvee_L C_m(L)]_L$ .

THEOREM 3.20.

Let  $L$  be a complete lattice such that  $1_L$  is  $m$ -inaccessible in  $L$  and  $m$  a regular infinite cardinal. Then the following conditions are equivalent:

- i.  $L$  is an  $m$ -algebraic lattice.
- ii. For every closure operator  $u : L \rightarrow L$ ,  $u$  is  $m$ -algebraic if and only if  $u$  is  $m$ -Tulipani.

## CHAPTER 4

For a non-empty set  $M$  and a closure system  $S$ ,  $E(M)$  denotes the complete lattice of all equivalences on  $M$ . To every closure system  $S$  on  $\exp M$  there corresponds a closure system  $e(S)$  on  $E(M)$ . If  $S$  is  $m$ -algebraic so is  $e(S)$ . Closure systems of the form  $e(S)$  are characterised, and a recursive construction of the closure operator corresponding to  $e(S)$  is given. Conditions on  $S$  which are necessary and sufficient for  $e(S)$  to be a subcomplete lattice of  $E(M)$  are presented. For regular  $m$  the  $m$ -compact elements of  $e(S)$ , where  $S$  is  $m$ -algebraic, are characterised in some situations. In fact this is done in a more general setting.

DEFINITION 4.1.

For a nonempty set  $M$  recall that we denote by  $E(M)$  the set of all equivalence relations on  $M$ . Given closure system  $S$  on  $\exp M$ , we shall call  $e(S)$  the set of all equivalences on a set  $M$ , whose equivalence classes are  $S$ -closed subsets of  $M$ :

$$e(S) = \{\sigma \in E(M); M/\sigma \subseteq S\}.$$

THEOREM 4.2.

*Let  $S$  be any closure system on a nonempty set  $M$ . Then  $e(S)$  is a closure system on  $E(M)$ . If  $S$  is an  $m$ -algebraic closure system, then so is  $e(S)$ .*

PROOF

Since  $M \in S$ , we have  $M^2 = \bigwedge_{E(M)} \emptyset \in e(S)$ . Take  $\emptyset \neq \Sigma \subseteq e(S)$  and let  $\sigma = \bigcap \Sigma$ . Let  $X \in M/\sigma$ . For any  $x \in X$ , we have

$$X = x/\sigma = \bigcap_{\tau \in \Sigma} x/\tau.$$

Now, for all  $\tau \in \Sigma$ , we have  $x/\tau \in S$ . Hence  $X \in S$  also, and so  $\sigma \in e(S)$ .

Suppose further that  $S$  is  $m$ -algebraic. Take  $\emptyset \neq \Sigma \subseteq e(S)$  such that  $\langle \Sigma, \subseteq \rangle$  is  $m$ -directed. Let  $\sigma = \cup \Sigma$ . Then  $\sigma \in E(M)$ . Take  $X \in M/\sigma$ . Then

$$X = x/\sigma = \bigcup_{\tau \in \Sigma} x/\tau.$$

However,  $\langle \Sigma, \subseteq \rangle$  is  $m$ -directed and so  $\langle \{x/\tau; \tau \in \Sigma\}, \subseteq \rangle$  is also  $m$ -directed. Hence  $X \in S$ , and so  $\sigma \in e(S)$ .

### PROPOSITION 4.3.

*Let  $m$  be any infinite cardinal. Then there exists a set  $M$  and a closure system  $S$  on  $\exp M$  such that  $e(S)$  is  $m$ -algebraic, but  $S$  is not  $m$ -algebraic.*

### PROOF

Using Lemma 1.9(ii) we only need to prove this for  $m$  regular. Let

$$S = \{X \subseteq m \oplus 1; X \text{ is hereditary}\} \setminus \{m\}.$$

Then  $S$  is a closure system on  $\exp m \oplus 1$  since the intersection of hereditary sets is always hereditary and if  $X \in S$  and  $m \subseteq X$  then  $X = m \oplus 1$ , and hence  $m$  cannot be an intersection of sets from  $S$ . Let  $T = m \subseteq S$ . Since  $m$  is regular,  $T$  must be  $m$ -directed. However  $\cup T = m \notin S$ . Thus  $S$  is not  $m$ -algebraic, but  $e(S) = \{(m \oplus 1)^2\}$  is  $m$ -algebraic.

### DEFINITION 4.4.

Let  $\Sigma \subseteq E(M)$ . We say that  $\Sigma$  is *closed under reconstruction* iff  $\Sigma$  satisfies the following property: If  $\sigma \in E(M)$  such that for every  $X \in M/\sigma$  there exists  $\tau \in \Sigma$  with  $X \in M/\tau$ , then  $\sigma \in \Sigma$  also.

The following proposition characterises closure systems of the form  $e(S)$ .

PROPOSITION 4.5.

Let  $\mathcal{T} \subseteq E(M)$ . Then  $\mathcal{T}$  is a closure system on  $E(M)$ , closed under reconstruction iff there exists a closure system  $S$  on  $\exp M$  such that  $\mathcal{T} = e(S)$ .

PROOF

( $\Rightarrow$ ): Define  $S = \{X \in \exp M; \text{there exists } \tau \in \mathcal{T} \text{ and } X \in M/\tau\} \cup \{\emptyset\}$ . It is easily verified that  $S$  is a closure system on  $\exp M$ . We show that  $\mathcal{T} = e(S)$ : Firstly, let  $\tau \in \mathcal{T}$ . By definition of  $S$ , we have that  $X \in S$  for every  $X \in M/\tau$ , and hence  $\tau \in e(S)$ . Secondly, let  $\sigma \in e(S)$ . Then for every  $X \in M/\sigma$  there exists  $\tau \in \mathcal{T}$  with  $X \in M/\tau$ . Hence by closure under reconstruction, we have  $\sigma \in \mathcal{T}$ .

( $\Leftarrow$ ): The converse of the proposition follows from the definitions.

REMARK 4.6.

We now present a construction of the closure operator  $u_e$  on  $E(M)$  corresponding to the closure system  $e(S)$ .

Fix  $\sigma \in E(M)$ . We define a sequence by recursion on the elements of the ordinal  $|M|^+$ , as follows: Set  $f_0(\sigma) = \sigma$ . Take  $0 \neq \zeta \in |M|^+$ , and suppose that for all  $\eta$  with  $\eta < \zeta \in |M|^+$ , an equivalence  $f_\eta(\sigma) \in E(M)$  has been defined such that  $\eta_1 \leq \eta_2 < \zeta$  implies  $f_{\eta_1}(\sigma) \subseteq f_{\eta_2}(\sigma)$ . Then:

If  $\zeta$  is a limit ordinal, define

$$f_\zeta(\sigma) = \bigcup_{\eta < \zeta} f_\eta(\sigma).$$

If  $\zeta = \xi \oplus 1$ , define

$$f_\zeta(\sigma) = \bigcup_{n=1}^{\infty} \{u(X_1)^2 \circ \dots \circ u(X_n)^2; X_1, \dots, X_n \in M/f_\xi(\sigma)\},$$

where  $u$  is the closure operator on  $\exp M$  corresponding to the closure system  $S$ .

OBSERVATION (1):

For all  $\zeta \in |M|^+$ , we have  $f_\zeta(\sigma) \in E(M)$ , and also for all  $\zeta_1 \leq \zeta_2 \in |M|^+$ , we have  $\sigma \subseteq f_{\zeta_1}(\sigma) \subseteq f_{\zeta_2}(\sigma) \subseteq u_e(\sigma)$ .

OBSERVATION (2):

Suppose there exists  $\zeta \in |M|^+$  such that  $f_\zeta(\sigma) \in e(S)$ . Then for all  $\eta \in |M|^+$ , with  $\zeta \leq \eta$  we have  $f_\zeta(\sigma) = f_\eta(\sigma)$ .

PROOF

We proceed by induction. Take  $\eta \in |M|^+$ , and suppose that for all  $\xi \in |M|^+$  with  $\zeta \leq \xi < \eta$  we have  $f_\zeta(\sigma) = f_\xi(\sigma)$ . If  $\eta$  is a limit ordinal then

$$f_\eta(\sigma) = \bigcup_{\xi < \eta} f_\xi(\sigma) = \bigcup_{\zeta \leq \xi < \eta} f_\xi(\sigma) = f_\zeta(\sigma).$$

On the other hand, if  $\eta = \rho \oplus 1$  then  $f_\rho(\sigma) = f_\zeta(\sigma) \in e(S)$  and thus for any  $X \in M/f_\rho(\sigma)$  we have  $X = u(X)$ . Thus

$$f_\eta(\sigma) = \bigcup_{n=1}^{\infty} \{X^n; X \in M/f_\rho(\sigma)\} = f_\rho(\sigma) = f_\zeta(\sigma).$$

OBSERVATION (3):

For any  $\zeta \in |M|^+$  we have:  $f_\zeta(\sigma) = f_{(\zeta \oplus 1)}(\sigma) \Leftrightarrow$  for every  $\eta \in |M|^+$  with  $\zeta \leq \eta$  we have  $f_\eta(\sigma) = f_\zeta(\sigma) = u_e(\sigma)$ .

PROOF

Suppose  $X \in M/f_\zeta(\sigma)$ . Then  $X \in M/f_{\zeta \oplus 1}(\sigma)$  as  $f_\zeta(\sigma) = f_{\zeta \oplus 1}(\sigma)$ . But, by definition of  $f_{\zeta \oplus 1}(\sigma)$ , we have that there exists  $Y \in M/f_{\zeta \oplus 1}(\sigma)$  such that  $X \subseteq$

$u(X) \subseteq Y$ . Hence,  $X = Y$ , and thus  $X = u(X)$ . Hence,  $f_\zeta(\sigma) \in e(S)$ , and so by Observation (2), we see that for all  $\eta \in |M|^+$  with  $\zeta \leq \eta$ , we have  $f_\eta(\sigma) = f_\zeta(\sigma)$ . Now by Observation (1),  $\sigma \subseteq f_\zeta(\sigma) \subseteq u_e(\sigma)$ . But  $f_\zeta(\sigma) \in e(S)$  implies that  $u_e(\sigma) \subseteq f_\zeta(\sigma)$ . Hence the result. The converse follows trivially.

OBSERVATION (4):

*There exists  $\zeta \in |M|^+$  such that  $f_\zeta(\sigma) = f_{(\zeta \oplus 1)}(\sigma)$ . If  $M$  is finite, then we can choose  $\zeta < |M/\sigma| \leq |M|$ .*

PROOF

Firstly, suppose  $M$  is infinite. Take  $X \in M/\sigma$  and let  $x \in X$ . For all  $\zeta \in |M|^+$  define  $X_\zeta = x/f_\zeta(\sigma)$ . Then  $C_X = \{\{X_\zeta; \zeta \in |M|^+\}; \subseteq\}$  is a chain. Suppose  $C_X$  has no greatest element. By Zorn's Lemma, choose  $\Gamma \subseteq |M|^+$  to be maximal with respect to the following property:

$$(\zeta, \eta \in \Gamma \text{ and } \zeta < \eta) \text{ implies } X_\zeta \subset X_\eta.$$

Thus  $\Gamma$  is cofinal with  $|M|^+$  and hence  $|\Gamma| = |M|^+$ . But then,

$$|M| \geq \left| \bigcup_{\zeta \in \Gamma} X_\zeta \right| \geq |\Gamma| = |M|^+,$$

which is clearly impossible. Hence  $C_X$  has a greatest element and thus for every  $X \in M/\sigma$  there exists  $\zeta(X) \in |M|^+$  such that for all  $\eta \in |M|^+$  with  $\zeta(X) \leq \eta$ , we have  $X_\eta = X_{\zeta(X)}$ . Now let  $\zeta = \sup \{\zeta(X); X \in M/\sigma\}$ . Since  $|M|^+$  is regular, we have that  $\zeta \in |M|^+$ , and by definition of  $\zeta$ , we have that  $f_\zeta(\sigma) = f_{\zeta \oplus 1}(\sigma)$ .

Secondly, suppose that  $M$  is finite. Let  $m = |M/\sigma|$  and suppose that  $\sigma \subset f_1(\sigma) \subset \dots \subset f_{m-1}(\sigma)$ . Thus we have that  $|M/f_1(\sigma)| \leq m - 1$ ,  $|M/f_2(\sigma)| \leq m - 2$ , etc. Especially,  $|M/f_{m-1}(\sigma)| \leq m - (m - 1) = 1$ , that is  $f_{m-1}(\sigma) = M^2 \in e(S)$ . Hence, by Observation (2)  $f_{m-1}(\sigma) = f_m(\sigma)$ .

REMARK 4.7.

By Observation (4) we can introduce the following ordinal:

$$\zeta(S, \sigma) = \min\{\zeta \in |M|^+; f_\zeta(\sigma) = f_{\zeta \oplus 1}(\sigma)\}.$$

By Observations (1) , (3) and (4) we have immediately that  $\zeta(S, \sigma)$  is the smallest index  $\zeta$  such that  $f_\zeta(\sigma) = u_e(\sigma)$ . Further for  $M$  infinite we have that  $\zeta(S, \sigma) < |M|^+$ , and for  $M$  finite we have that  $\zeta(S, \sigma) < |M/\sigma| \leq |M|$ . A natural question arises: Are the upperbounds on  $\zeta(S, \sigma)$  given here, the best possible? The answer is “yes”, and in fact something stronger may be proved.

PROPOSITION 4.8.

*Let  $M$  be any infinite set, and let  $\xi$  be any ordinal with  $\xi < |M|^+$ . Then there exists a closure system  $S$  on  $\exp M$  and  $\sigma \in E(M)$  such that  $\zeta(S, \sigma) = \xi$ .*

PROOF

The cases for  $\xi$  being a limit or nonlimit ordinal are slightly different. For all  $\zeta \leq \xi$  define

$$A_\zeta = \{0, 1\} \times \{\zeta\}, \text{ and } B_\zeta = \left(\bigcup_{\eta \leq \zeta} A_\eta\right) \cup \{\langle 0, \zeta \oplus 1 \rangle\}.$$

If  $\xi$  is a limit ordinal then define  $N = \bigcup_{\zeta < \xi} A_\zeta$ , and if  $\xi$  is a nonlimit ordinal, then define  $N = \bigcup_{\zeta \leq \xi} A_\zeta$ . In either case we have that  $|N| \leq |M|$ , and so we regard  $N$  as a subset of  $M$ .

- If  $\xi$  is a limit ordinal, then define:

$$S = \{A_\zeta; 0 \neq \zeta < \xi\} \cup \{\langle 0, \zeta \rangle; 0 \neq \zeta < \xi\} \cup \{B_\zeta; \zeta < \xi\} \cup \{N, M \setminus N, M, \emptyset\}$$

- If  $\zeta$  is a nonlimit ordinal, then define:

$$S = \{A_\zeta; 0 \neq \zeta \leq \xi\} \cup \{\langle 0, \zeta \rangle; 0 \neq \zeta \leq \xi\} \cup \{B_\zeta; \zeta < \xi\} \cup \{N, M \setminus N, M, \emptyset\}$$



In either case  $S$  is easily seen to be a closure system on  $\exp M$  (see diagram that follows).

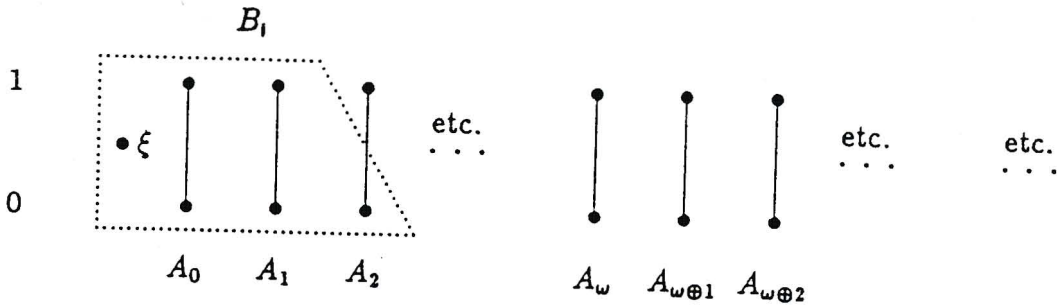

DIAGRAM 4.1.

Further:

- If  $\xi$  is a limit ordinal, then define

$$\sigma = \bigcup \{A_\zeta^2; \zeta < \xi\} \cup (M \setminus N)^2.$$

- If  $\xi$  is a nonlimit ordinal, then define

$$\sigma = \bigcup \{A_\zeta^2; \zeta \leq \xi\} \cup (M \setminus N)^2.$$

Again, in either case we see that  $\sigma \in E(M)$  and it is easily verified that  $\zeta(S, \sigma) = \xi$ .

REMARK 4.9.

A similar construction to that employed in Proposition 4.8, but transferred to the case for  $M$  finite, will show that the upper bound on  $\zeta(S, \sigma)$  given for the finite case is the lowest possible.

With additional assumptions on  $S$  it will be shown that it is possible to improve on the upper bound given for  $M$  an infinite set:

THEOREM 4.10.

If  $S$  is an  $m$ -algebraic closure system on  $\exp M$ , then for every  $\sigma \in E(M)$ ,  $\xi(S, \sigma) \leq \bar{m}$ .

PROOF

We may obviously assume that  $\bar{m} < |M|^+$ . Take  $X \in M/f_{\bar{m}}(\sigma)$  and let  $\emptyset \neq Y \subseteq X$  such that  $|Y| < \bar{m}$ . Now  $\bar{m}$  is a limit ordinal and hence  $f_{\bar{m}}(\sigma) = \bigcup_{\zeta < \bar{m}} f_{\zeta}(\sigma)$ . Take  $x \in X$ . Then  $X = x/f_{\bar{m}}(\sigma) = \bigcup_{\zeta < \bar{m}} x/f_{\zeta}(\sigma)$ . Hence for every  $y \in Y$  we have that there exists  $\zeta_y < \bar{m}$  such that  $y \in x/f_{\zeta_y}(\sigma)$ . Define  $\zeta = \sup \{\zeta_y; y \in Y\}$ . Since  $|Y| < \bar{m}$  and  $\bar{m}$  is regular, we have that  $\zeta < \bar{m}$ , and  $Y \subseteq x/f_{\zeta}(\sigma)$ . Hence there exists  $Z \in M/f_{\bar{m}}(\sigma)$  so that  $u(Y) \subseteq Z$ . But then,  $\emptyset \neq Y \subseteq X \cap Z$  and hence  $X = Z$ . So we have shown that  $u(Y) \subseteq X$ .

Now, Remark 1.13 and Corollary 1.14 we have that  $S$  is  $m$ -algebraic if and only if  $S$  is  $\bar{m}$ -algebraic, and since  $\bar{m}$  is regular we have :

$$u(X) = \bigcup \{u(Y); \emptyset \neq Y \subseteq X \text{ and } |Y| < \bar{m}\}$$

Thus  $u(X) = X$  and hence  $f_{\bar{m} \oplus 1}(\sigma) = f_{\bar{m}}(\sigma)$ .

REMARK 4.11.

Let  $M$  be an infinite set. Consider the closure system  $S$  defined in Proposition 4.8 where  $\xi = m$  is an infinite cardinal,  $m < |M|^+$ . Then  $S$  is  $m$ -algebraic.

PROOF

Let  $\emptyset \neq T \subseteq S$  such that  $\langle T, \subseteq \rangle$  is  $m$ -directed. Trivially, we may assume that  $N, M, \emptyset, \notin T$ . Notice that  $|S| = |\xi| = m$ . Thus we have that  $|T| \leq m$ . If  $|T| < m$ , then  $T$  must have a maximal element. Hence  $\bigcup T \in S$ . So suppose  $|T| = m$ .

Then  $T = W \cup V$ , where  $W = \{B_\zeta; B_\zeta \in T\}$  and  $V = \{D \in T; \text{there exists } \zeta < m \text{ with } D \subseteq A_\zeta\}$ , and:

- Either  $|W| = m$ , in which case let  $\Gamma = \{\zeta; B_\zeta \in T\}$ . Then  $\Gamma$  is cofinal with  $m$  and thus  $\bigcup T \supseteq \bigcup_{\zeta \in \Gamma} B_\zeta = N$  and hence  $\bigcup T = N \in S$ .
- Or  $|V| = m$ , in which case let  $\Sigma = \{\zeta; \text{there exists } D \subseteq A_\zeta \text{ with } D \in T\}$ . Then  $\Sigma$  is cofinal with  $m$ . However, for  $\zeta, \rho \in \Sigma$  with  $\zeta \neq \rho$ , by the  $m$ -directedness of  $T$ , we have that there exists  $\eta = \eta(\zeta, \rho) < m$  such that  $B_\eta \in T$  and  $A_\zeta \cup A_\rho \subseteq B_\eta$ . By the cofinality of  $\Sigma$  with  $m$  we have  $\bigcup T \supseteq \bigcup_{\zeta \neq \rho \in \Sigma} B_{\eta(\zeta, \rho)} = N$  and hence  $\bigcup T = N \in S$ .

So  $S$  is indeed  $m$ -algebraic, and thus for  $m$  regular we see that the upper bound given in Theorem 4.10, is the best possible. However, using Remark 1.13 and Corollary 1.14 once again, we see that for singular  $m$ , we also cannot improve on the upper bound for  $\zeta(S, \sigma)$  given there.

We consider hereafter the complete lattice  $\langle e(S), \subseteq \rangle$ . For ease of notation this lattice has been denoted simply by  $e(S)$ . The atoms of  $S$  are precisely the closed sets  $u(\{x\})$  where  $x \in M$ . Also, the least element of  $e(S)$  is denoted by  $u_e(id_M)$ . We find conditions under which  $e(S)$  is a sublattice of  $E(M)$ . We make use of the following properties of  $S$  which have a strong and interesting influence on the structure of  $e(S)$ :

$$T_1 : \{\{x\}; x \in M\} \subseteq S,$$

$$P : \{u(\{x\}); x \in M\} \text{ is a partition on } M.$$

We notice that  $T_1$  implies  $P$ , and that  $T_1$  is quite a strong property of  $S$ .

DEFINITION 4.12.

Let  $X \subseteq M$ . Then define

$$\sigma(X) = X^2 \cup \bigcup \{u(\{x\})^2; x \in M\}.$$

LEMMA 4.13.

Let  $S$  be a closure system on  $\exp M$ .

- i. Suppose that  $S$  satisfies property  $P$ , and let  $X \subseteq M$ . Then  $X \in S$  if and only if  $Y \subseteq X$  for some  $Y \in S$  and  $\sigma(X) \in e(S)$ . In this case  $X \in M/\sigma(X)$ .
- ii.  $S$  satisfies property  $P$  if and only if for every  $X \in S$  there exists  $\sigma \in e(S)$  such that  $X \in M/\sigma$ .

PROOF

For (i). ( $\Rightarrow$ ): Evidently  $\sigma(X)$  is a reflexive and symmetric relation on  $M$ . Suppose that  $\langle a, b \rangle, \langle b, c \rangle \in \sigma(X)$ . If  $\langle a, b \rangle, \langle b, c \rangle \in X^2$  then  $\langle a, c \rangle \in \sigma(X)$  also. If  $\langle a, b \rangle \in u(\{x\})^2$  and  $\langle b, c \rangle \in u(\{y\})^2$  then  $u(\{x\}) \cap u(\{y\}) \neq \emptyset$  and so by property  $P$  we conclude  $u(\{x\}) = u(\{y\})$ , which again yields  $\langle a, c \rangle \in \sigma(X)$ . The last case to check is  $\langle a, b \rangle \in X^2$  and  $\langle b, c \rangle \in u(\{x\})^2$ . Then  $u(\{x\}) = u(\{b\}) = u(\{c\}) \subseteq X$  by property  $P$  and the fact that  $X \in S$ . Hence  $\langle a, c \rangle \in \sigma(X)$  and thus we have shown  $\sigma(X)$  to be transitive, i.e.  $\sigma(X) \in E(M)$ . As  $X \in S$  it follows that  $X = \bigcup \{u(\{x\}); x \in X\}$ , and thus by property  $P$  we have

$$M/\sigma(X) = \{X\} \cup \{u(\{x\}); x \in M \setminus X\}.$$

( $\Leftarrow$ ): Evidently  $X^2 \subseteq \sigma(X)$ . If  $X \in M/\sigma(X)$  then  $X \in S$ . So suppose that for some  $y \in M \setminus X$ , there exists an  $x \in X$  such that  $\langle x, y \rangle \in \sigma(X)$ . By the transitivity

of  $\sigma(X)$ , it follows that for every  $x \in X$ ,  $\langle x, y \rangle \in \sigma(X)$ . Pick any  $x \in X$ . Then  $\langle x, y \rangle \in u(\{z\})^2$  for some  $z \in M$ . Thus by property  $P$ ,  $u(\{x\}) = u(\{y\}) = u(\{z\})$ .

It now follows that

$$X \subseteq \bigcup_{x \in X} u(\{x\}) = u(\{y\}).$$

However,  $X$  contains an element of  $S$  and so we must have  $X = u(\{y\}) \in S$ .

For (ii). ( $\Rightarrow$ ): Take  $X \in S$ . By (i) above  $\sigma(X) \in e(S)$  and  $X \in M/\sigma(X)$ .

( $\Leftarrow$ ): For the reverse implication, let  $\tau_x \in e(S)$ , for every  $x \in M$ , such that  $u(x) \in M/\tau_x$ . Define  $\tau = \bigcap_{x \in M} \tau_x$ . Then  $\tau \in e(S)$ . Now let  $x, y \in M$ . Since  $x \in x/\tau_y \in S$ , we have  $x/\tau_x = u(x) \subseteq x/\tau_y$ , and thus  $x/\tau = \bigcap_{y \in M} x/\tau_y = u(x)$  and this completes the proof.

#### COROLLARY 4.14.

*Let  $S$  be a closure system on  $\exp M$  satisfying property  $P$ . Then  $u_e(id_M) = \bigcup \{u(x)^2; x \in M\}$ .*

#### COROLLARY 4.15.

*Let  $S_1$  and  $S_2$  be closure systems on  $\exp M$  satisfying property  $P$ . Then  $e(S_1) = e(S_2)$  if and only if  $S_1 = S_2$ .*

#### THEOREM 4.16.

*Let  $S$  be a closure system on  $\exp M$  satisfying property  $P$ . Then  $S$  is  $m$ -algebraic  $\Leftrightarrow e(S)$  is  $m$ -algebraic.*

#### PROOF

( $\Rightarrow$ ): The forward implication follows from Theorem 4.2.

( $\Leftarrow$ .) For the reverse implication let  $T \subseteq S$  such that  $\langle T, \subseteq \rangle$  is  $m$ -directed. Then it is easily seen that  $\langle \Sigma, \subseteq \rangle$ , where  $\Sigma = \{\sigma(X); X \in T\}$ , is also  $m$ -directed. Since  $e(S)$  is assumed to be  $m$ -algebraic, we have that  $\sigma = \bigcup \Sigma \in e(S)$ . However,  $\sigma = (\bigcup T)^2 \cup u_e(id_M)$ . Using a similar argument to that employed in the proof of Lemma 4.13(i) we see that  $\bigcup T \in M/\sigma$ , and hence  $\bigcup T \in S$ .

**REMARK 4.17.**

We introduce the following seemingly unnatural property of  $S$ , but the results that follow show that it is necessary:

$Q$  : For every  $X, Y \in S$  such that  $X \cap Y \neq \emptyset$  we have that  $X \cup Y \in S$ .

Since the least element of  $e(S)$  is  $u_e(id_M)$  it follows that  $e(S)$  is contained in the principal filter of lattice  $E(M)$  generated by  $u_e(id_M)$ .

**THEOREM 4.18.**

*Let  $S$  be a closure system on  $\exp M$  satisfying property  $P$ . Denote by  $F$  the principal filter of  $E(M)$  generated by  $u_e(id_M)$ .*

- i. If  $e(S)$  is a sublattice of  $E(M)$  then  $S$  satisfies property  $Q$ .*
- ii. If  $S$  is  $\omega$ -algebraic and satisfies property  $Q$ , then  $e(S)$  is a subcomplete lattice of  $F$ .*

**PROOF**

For (i). Take  $X, Y \in S$  such that  $X \cap Y \neq \emptyset$ , and let  $\sigma = \sigma(X) \vee_{e(S)} \sigma(Y)$ . Then it is easily seen that  $\sigma = \sigma(X) \vee_{E(M)} \sigma(Y) = (X \cup Y)^2 \cup u_e(id_M) = \sigma(X \cup Y)$ . Thus, by Lemma 4.13(i), we have that  $X \cup Y \in S$ .

For (iii). Take  $\Sigma \subseteq e(S)$  and let  $\sigma = \bigvee_F \Sigma$ . If  $\Sigma = \emptyset$ , then  $\sigma = u_e(id_M) \in e(S)$ . So let  $\Sigma \neq \emptyset$ . Then  $\sigma = \bigvee_{E(M)} \Sigma$ . Take  $X \in M/\sigma$  and a finite  $Y = \{y_1, \dots, y_m\} \subseteq X$ . Take  $y_i, y_j \in Y$  where  $i \neq j$ . Since  $y_i \sigma y_j$  there exists a sequence  $y_i = a_0 \sigma_1 a_1 \dots \sigma_n a_n = y_j$  where, for each  $k = 1, \dots, n$ , we have  $\sigma_k \in \Sigma$  and necessarily,  $a_k \in X$ , for all  $k = 0, \dots, n$ . However, for each  $k = 1, \dots, n$ , we have  $a_{k-1} \in a_k / \sigma_k \in S$ . Thus we have that  $\bigcup_{k=1}^n (a_k / \sigma_k) \in S$ . Hence we have shown that for  $i, j \in \{1, \dots, m\}$  where  $i \neq j$ , there exists  $X_{i,j} \subseteq X$  such that  $y_i, y_j \in X_{i,j} \in S$ . Especially,  $Y \subseteq X_{1,2} \cup \dots \cup X_{m-1,m} \in S$ , and so  $u(Y) \subseteq X$ . However, since  $S$  is algebraic, we have that  $u(X) = \bigcup \{u(Y); \emptyset \neq Y \subseteq X \text{ and } Y \text{ is finite}\}$ . Hence  $u(X) = X$ , that is  $X \in S$ . Thus  $\sigma \in e(S)$ .

#### COROLLARY 4.19.

*Let  $S$  be a closure system satisfying property  $P$ , and let  $F$  denote the principal filter of  $E(M)$  generated by  $u_e(id_M)$ .*

- i.  $e(S)$  is a subcomplete lattice of  $F$  if and only if  $S$  is  $\omega$ -algebraic and satisfies property  $Q$ .*
- ii. If  $S$  is  $\omega$ -algebraic, then  $e(S)$  is a sublattice of  $E(M)$  if and only if  $e(S)$  is a complete sublattice of  $F$  if and only if  $S$  satisfies property  $Q$ .*

#### PROOF

This follows directly from Theorem 4.18.

#### COROLLARY 4.20.

*Let  $S$  be any closure system on  $\exp M$ . Then  $\langle e(S), \subseteq \rangle$  is a complete sublattice of  $E(M)$  if and only if  $S$  is  $\omega$ -algebraic and satisfies both properties  $T_1$  and  $Q$ .*

PROOF

Notice that  $S$  satisfies property  $T_1$  if and only if  $id_M \in e(S)$  if and only if  $u_e(id_M) = id_M$  if and only if the principal filter of  $E(M)$  generated by  $u_e(id_M)$  is the whole of  $E(M)$ .

( $\Rightarrow$ ):) Since  $id_M = \bigvee_{E(M)} \emptyset = \bigvee_{\langle e(S), \subseteq \rangle} \emptyset$ , we have that  $id_M \in e(S)$  and thus  $S$  satisfies  $T_1$ . Since  $T_1$  implies  $P$  we have by Corollary 4.19(i) the proof is complete.

( $\Leftarrow$ ):) For the reverse implication Corollary 4.19(i) implies that  $\langle e(S), \subseteq \rangle$  is a subcomplete lattice of  $\langle \{u_e(id_M)\}, \subseteq \rangle = E(M)$ .

REMARK 4.21.

We define a local property of closure systems on  $E(M)$  which allows us to work quite freely with the equivalence classes. We will use  $\mathcal{T}$  to denote an arbitrary closure system on  $E(M)$ .  $u_\tau$  denotes the corresponding closure operator. The least element of the complete lattice  $\langle \mathcal{T}, \subseteq \rangle$  is denoted by  $\vartheta$ . We define:

$$S(\mathcal{T}) = \bigcup \{M/\sigma; \sigma \in \mathcal{T}\} \cup \{\emptyset\}.$$

It is easily verified that  $S(\mathcal{T})$  is a closure system on  $\exp M$  with the property  $P$ . Trivially,  $\mathcal{T} \subseteq e(S(\mathcal{T}))$ . For  $X \in S(\mathcal{T})$  we define:

$$\epsilon(X) = \vartheta \cup X^2.$$

Obviously  $\epsilon(X) \in E(M)$ .

DEFINITION 4.22.

Let  $\mathcal{T}$  be a closure system on  $\exp M$ .  $\mathcal{T}$  is said to be *local* if and only if the following properties hold:

- (a) For every  $X \in S(\mathcal{T})$ , we have  $\epsilon(X) \in \mathcal{T}$ , and



(b) For all  $\sigma \in \mathcal{T}$  and  $\rho \in E(M)$ , if  $\rho \subseteq \sigma$  then:

$$u_{\mathcal{T}}(\rho) = \bigcup \{u_{\mathcal{T}}(\rho \cap \epsilon(X)); X \in (M/\sigma)\}.$$

REMARK 4.23.

Suppose that  $\mathcal{T}$  is a closure system on  $E(M)$  satisfying the property (i) of Definition 4.22 above. Let  $\sigma \in \mathcal{T}$  and  $\rho \in E(M)$  with  $\rho \subseteq \sigma$ . Define

$$\tau = \bigcup \{u_{\mathcal{T}}(\rho \cap \epsilon(X)); X \in M/\sigma\}.$$

(a). It is easily verified that  $\rho \subseteq \tau \subseteq u_{\mathcal{T}}(\rho) \subseteq \sigma$ . It is also true that for every  $X \in S(\mathcal{T})$ ,  $u_{\mathcal{T}}(\rho \cap \epsilon(X)) \subseteq \epsilon(X)$ .

(b). Further,  $\tau \in E(M)$ : the reflexivity and symmetry of  $\tau$  is immediate. Suppose that  $x\tau y$  and  $y\tau z$ . Then there exist  $U, V \in M/\sigma$  such that  $\langle x, y \rangle \in u_{\mathcal{T}}(\rho \cap \epsilon(U))$  and  $\langle y, z \rangle \in u_{\mathcal{T}}(\rho \cap \epsilon(V))$ . If  $x\vartheta y$ , then, as  $\vartheta \subseteq u_{\mathcal{T}}(\rho \cap \epsilon(V))$ , it follows that  $x\tau z$ . Similarly, if  $y\vartheta z$ , then  $x\tau z$ . Suppose then that  $\langle x, y \rangle \notin \vartheta$  and  $\langle y, z \rangle \notin \vartheta$ . Then  $\langle x, y \rangle \in \epsilon(U) \setminus \vartheta = U^2$ , and  $\langle y, z \rangle \in \epsilon(V)(V) \setminus \vartheta = V^2$ . Thus  $U = V$  and so  $x\tau z$ .

(c). We show that

$$(M/\tau) \setminus (M/\vartheta) = (\bigcup \{M/u_{\mathcal{T}}(\rho \cap \epsilon(X)); X \in M/\sigma\}) \setminus (M/\vartheta).$$

Let  $X \in M/\tau$ . Since  $\tau \subseteq \sigma$ , there exists  $Y \in M/\sigma$  such that  $X \subseteq Y$ . Let  $a, b \in X$ . As  $a\tau b$ , there exists  $Z \in M/\sigma$  such that  $\langle a, b \rangle \in u_{\mathcal{T}}(\rho \cap \epsilon(Z)) \subseteq \epsilon(Z)$ . Then, either  $a\vartheta b$  or  $a, b \in Z$ . The latter case yields  $Y = Z$  and so in either case we must have  $\langle a, b \rangle \in u_{\mathcal{T}}(\rho \cap \epsilon(Y))$ . Hence,  $X^2 \subseteq u_{\mathcal{T}}(\rho \cap \epsilon(Y))$ . Thus there exists  $W \in M/u_{\mathcal{T}}(\rho \cap \epsilon(Y))$  such that  $X \subseteq W$ . But  $u_{\mathcal{T}}(\rho \cap \epsilon(Y)) \subseteq \tau$ , and so there exists  $X' \in M/\tau$  such that  $X \subseteq W \subseteq X'$ . Since both  $X, X' \in M/\tau$ , it follows that  $X = X'$

and so  $X = W$ , i.e. we have shown that

$$(M/\tau) \subseteq \bigcup \{M/u_{\mathcal{T}}(\rho \cap \epsilon(X)); X \in M/\sigma\},$$

and one inclusion follows. For the converse, let  $X \in (M/u_{\mathcal{T}}(\rho \cap \epsilon(Y))) \setminus (M/\vartheta)$ , where  $Y \in M/\sigma$ . Since  $\vartheta \subseteq u_{\mathcal{T}}(\rho \cap \epsilon(Y))$ , it follows that for each  $x \in X$  there exists  $y \in X$  such that  $\langle x, y \rangle \notin \vartheta$ . Thus  $\langle x, y \rangle \in u_{\mathcal{T}}(\rho \cap \epsilon(Y)) \subseteq \epsilon(Y) = Y^2 \cup \vartheta$ . Hence  $x, y \in Y$ , i.e.  $X \subseteq Y$ .

Now it is immediate that  $X^2 \subseteq \tau$ , i.e. there exists  $Z \in M/\tau$  such that  $X \subseteq Z$ . Hence by the inclusion that has already been proved, there exists  $W \in M/\sigma$  such that  $Z \in M/u_{\mathcal{T}}(\rho \cap \epsilon(W))$ . Again, for every  $x \in X$  there exists  $y \in X$  such that  $\langle x, y \rangle \notin \vartheta$ . Hence,  $X \subseteq W$  and so  $W = Y$ . It then follows that  $X = Z$ , and the converse inclusion has been proved.

We now provide an example of a local closure system on  $E(M)$ :

EXAMPLE 4.24.

Let  $S$  be a closure system on  $\exp M$  satisfying property  $P$ . We show that  $\mathcal{T} = e(S)$  is a local closure system on  $E(M)$ . Firstly, Lemma 4.13(ii) yields  $S(\mathcal{T}) = S$ . Also,  $\epsilon(X) = \sigma(X)$ , where  $\sigma(X)$  is as defined in Definition 4.12. Hence, from Lemma 4.13(i),  $\epsilon(X) \in \mathcal{T}$  for each  $X \in S$ . Consider the second condition of Definition 4.23. Again we use the notation of Remark 4.23. It is immediate from part 3 of Remark 4.24 that each  $\tau$ -equivalence class must be  $S$ -closed, and thus  $\tau \in e(S) = \mathcal{T}$ . Hence  $\tau = u_{\mathcal{T}}(\rho)$  and  $\mathcal{T}$  is a local closure system on  $E(M)$ .

LEMMA 4.25.

*Let  $\mathcal{T}$  be a local closure system on  $E(M)$ . Then:*

- i. Let  $\alpha, \beta \in \mathcal{T}$ , let  $\emptyset \neq S \subseteq M/\alpha$  and suppose that  $\beta \subseteq \bigcup \{\epsilon(X); X \in$*

$(M/\alpha)\setminus S$ . Then

$$\beta \cup \bigcup \{\epsilon(X); X \in S\} \in \mathcal{T}$$

*Epecially,*

$$\bigcup \{\epsilon(X); X \in S\} \in \mathcal{T}.$$

ii. Let  $\rho \in E(M)$  and let  $X \in (M/u_{\mathcal{T}}(\rho))\setminus(M/\vartheta)$ . Then there exists  $Y \in M/\rho$  such that  $2 \leq |Y|$  and  $Y \subseteq X$ .

iii. For every  $\rho \in E(M)$  we have

$$|(M/u_{\mathcal{T}}(\rho))\setminus(M/\vartheta)| \leq |(M/\rho)\setminus(M/id_M)|.$$

### PROOF

(i) Let  $\rho = \beta \cup \bigcup \{\epsilon(X); X \in S\}$ . Then  $\rho \in E(M)$  and  $\rho \subseteq \alpha \in \mathcal{T}$ . Hence by the second property of Definition 4.22, we have:

$$u_{\mathcal{T}}(\rho) = \bigcup \{u_{\mathcal{T}}(\rho \cap \epsilon(X)); X \in (M/\alpha)\}.$$

Now, if  $X \in S$ , then  $\rho \cap \epsilon(X) = \epsilon(X)$ , and hence  $u_{\mathcal{T}}(\rho \cap \epsilon(X)) = \epsilon(X)$ . If  $X \in (M/\alpha)\setminus S$ , then  $\rho \cap \epsilon(X) = \beta \cap \epsilon(X) \in \mathcal{T}$ . Thus  $u_{\mathcal{T}}(\rho \cap \epsilon(X)) = \beta \cap \epsilon(X)$ . Hence we have:

$$\begin{aligned} u_{\mathcal{T}}(\rho) &= \bigcup \{\beta \cap \epsilon(X); X \in (M/\alpha)\setminus S\} \cup \bigcup \{\epsilon(X); X \in S\} \\ &= (\beta \cap \bigcup \{\epsilon(X); X \in (M/\alpha)\setminus S\}) \cup \bigcup \{\epsilon(X); X \in S\} \\ &= \beta \cup \bigcup \{\epsilon(X); X \in S\} \\ &= \rho. \end{aligned}$$

Thus  $\rho \in \mathcal{T}$ . Now letting  $\beta = \vartheta$  we have immediately that  $\bigcup \{\epsilon(X); X \in S\} \in \mathcal{T}$  also.

(ii) Suppose that for every  $Y \in M/\rho$  with  $Y \subseteq X$ , we have  $|Y| = 1$ . Let

$$\alpha = \bigcup \{ \epsilon(Z); Z \in (M/u_{\mathcal{T}}(\rho)) \setminus \{X\} \}.$$

Then  $\rho \subseteq \alpha$  and  $\alpha \in \mathcal{T}$  by (i), above. However, then the choice of  $X$  yields  $\alpha \subset u_{\mathcal{T}}(\rho)$ !

This is impossible, and hence the result.

(iii) This follows directly from (ii).

#### DEFINITION 4.26.

Let  $\mathcal{T}$  be a local closure system on  $E(M)$ . Then for each  $X \in S(\mathcal{T})$  we define:

$$d_{\mathcal{T}}(X) = \min \{ |Y|; Y \subseteq X \text{ and } \epsilon(X) = u_{\mathcal{T}}(Y^2 \cup id_M) \}.$$

#### REMARK 4.27.

If  $S$  is a closure system on  $\exp M$  with property  $P$ , then for each  $X \in S(e(S)) = S$ , we have

$$d_{e(S)}(X) = \min \{ |Y|; Y \subseteq X \text{ and } u_S(Y) = X \}.$$

#### LEMMA 4.28.

Let  $\mathcal{T}$  be a local closure system on  $E(M)$ . Let  $\rho \in E(M)$  and  $X \in (M/u_{\mathcal{T}}(\rho)) \setminus (M/\vartheta)$ .

Then:

$$d_{\mathcal{T}}(X) \leq \Sigma \{ |Z|; Z \in M/\rho, Z \subseteq X, 2 \leq |Z| \}.$$

#### PROOF

Let  $W = \bigcup \{ Z \in M/\rho; Z \subseteq X \text{ and } 2 \leq |Z| \}$ . By the second condition of Lemma 4.25,  $W \neq \emptyset$ . Now for some  $V \subseteq X$  we have  $u_{\mathcal{T}}(W^2 \cup id_M) = \epsilon(V)$ . Let  $\bar{\rho} = \epsilon(V) \cup \bigcup \{ \epsilon(Z); Z \in (M/u_{\mathcal{T}}(\rho)) \setminus \{X\} \}$ . Then  $\rho \subseteq \bar{\rho} \subseteq u_{\mathcal{T}}(\rho)$  and from the

first condition of Lemma 4.25, we have that  $\bar{\rho} \in \mathcal{T}$ . Hence  $\bar{\rho} = u_{\mathcal{T}}(\rho)$ , and we have  $\epsilon(X) = \epsilon(V)$ . Hence the result follows from the definition of  $d_{\mathcal{T}}(X)$ .

REMARK 4.29.

The lattice  $E(M)$  is easily seen to be an  $\omega$ -algebraic lattice, and therefore also  $n$ -algebraic for each infinite cardinal  $n$ . The following results characterise the  $m$ -compact elements of  $E(M)$ .

LEMMA 4.30.

*Let  $m$  be singular and  $\rho \in E(M)$  be  $m$ -compact. Then there exists  $n$  regular,  $n < m$  such that  $\rho$  is  $n$ -compact.*

PROOF

Since  $E(M)$  is  $\omega$ -algebraic, it implies that  $\rho = \bigvee_{E(M)} \{\sigma_i; i \in I\}$  where  $\sigma_i$  are  $\omega$ -compact in  $E(M)$ . But  $\rho$  is  $m$ -compact in  $E(M)$  and hence we may, without loss of generality, assume  $|I| < m$ .

Let  $n = (\omega \cdot |I|)^+ < m$  as  $m$  is a limit cardinal. We show  $\rho$  is in fact  $n$ -compact. Let  $\rho \leq \bigvee_{E(M)} \{\tau_j; j \in J\}$ . Then for each  $i \in I$ ,  $\sigma_i \leq \bigvee_{E(M)} \{\tau_j; j \in J\}$  and as  $\sigma_i$  is  $\omega$ -compact we have

$$\sigma_i \leq \bigvee_{E(M)} \{\tau_j; j \in J_i\} \text{ where } J_i \subseteq J \text{ and } |J_i| < \omega.$$

Consequently,

$$\begin{aligned} \rho &\leq \bigvee_{E(M)} \left\{ \bigvee_{E(M)} \{\tau_j; j \in J_i; i \in I\} \right\} \\ &= \bigvee_{E(M)} \left( \bigcup_{i \in I} \{\tau_j; j \in J_i\} \right). \end{aligned}$$

Further,

$$\begin{aligned} |\bigcup_{i \in I} \{\tau_j; j \in J_i\}| &\leq \omega \cdot |I| \\ &< (\omega \cdot |I|)^+ \\ &= n, \end{aligned}$$

as required.

**LEMMA 4.31.**

Let  $m$  be a regular cardinal and  $\rho \in E(M)$ . Then  $\rho$  is  $m$ -compact if and only if the following two conditions hold:

- i.  $|(M/\rho) \setminus (M/id_M)| < m$ ,
- ii. For all  $X \in M/\rho$ ,  $|X| < m$ .

**PROOF**

( $\Rightarrow$ ): Let  $\rho \in E(M)$  and  $\rho$   $m$ -compact. For all  $X \in (M/\rho) \setminus (M/id_M)$ , let  $\sigma_X = X^2 \cup id_M$ . Now we prove that  $\rho = \bigcup \{\sigma_X; X \in (M/\rho) \setminus (M/id_M)\}$ . For let  $x \neq y$ ,  $\langle x, y \rangle \in \rho$  implies that  $\{x, y\} \subseteq X \in (M/\rho) \setminus (M/id_M)$ . Hence  $\langle x, y \rangle \in \sigma_X$  and so  $\langle x, y \rangle \in \bigcup \sigma_X$ . Suppose that  $\langle x, y \rangle \in \bigcup \sigma_X$ . This implies that  $\langle x, y \rangle \in \sigma_X$ , for some  $X \in (M/\rho) \setminus (M/id_M)$ . Thus  $\{x, y\} \subseteq X \in M/\rho$ . Hence we have  $\langle x, y \rangle \in \rho$  and we have thus shown that  $\rho = \bigvee_{E(M)} \{\sigma_X; X \in (M/\rho) \setminus (M/id_M)\}$ . But by the  $m$ -compactness of  $\rho$  we have that  $\rho = \bigvee_{E(M)} \{\sigma_X; X \in A\}$ , where  $A \subseteq (M/\rho) \setminus (M/id_M)$  and  $|A| < m$ . But then it means that  $A = (M/\rho) \setminus (M/id_M)$  and so  $|(M/\rho) \setminus (M/id_M)| < m$  and condition (i) holds.

For (ii) let  $X \in (M/\rho) \setminus (M/id_M)$ . Take  $a, b \in X$ ,  $a \neq b$ . Define  $\tau_{\{a,b\}} = (\rho \setminus X^2) \cup \{a, b\}^2 \cup id_X$ . But then we have that  $\rho = \bigcup \{\tau_{\{a,b\}}; \{a, b\} \subseteq X, a \neq b\}$ . Thus we

have:

$$|\{\tau_{\{a,b\}}; a, b \in X, a \neq b\}| < m$$

$$|\{\{a, b\}; a, b \in X, a \neq b\}| < m,$$

and so  $|X| < m$ .

( $\Leftarrow$ ):) Suppose that  $\rho$  satisfies conditions (i) and (ii). Let  $\rho \leq \bigvee_{E(M)} \{\sigma_i; i \in I\}$ . This implies that for all  $X \in (M/\rho) \setminus (M/id_M)$ ,  $X^2 \subseteq \rho$  and so  $X^2 \subseteq \bigvee_{E(M)} \{\sigma_i; i \in I\}$ . Take  $a, b \in X$ ,  $a \neq b$ . Then  $\langle a, b \rangle \in \bigvee_{E(M)} \Sigma_{\langle a, b \rangle}$  where  $\Sigma_{\langle a, b \rangle} \subseteq \{\sigma_i; i \in I\}$  and  $|\Sigma_{\langle a, b \rangle}| < \omega$ . Thus we have that  $|\bigcup \{\Sigma_{\langle a, b \rangle}; a, b \in X\}| < m$  by (ii). Let  $\Sigma_X = \bigcup \{\Sigma_{\langle a, b \rangle}; a, b \in X\}$ . Then  $|\Sigma_X| < m$  and  $X^2 \subseteq \bigvee_{E(M)} \Sigma_X$ . Thus we have that  $\rho \subseteq \bigvee_{E(M)} (\bigcup \{\Sigma_X; X \in (M/\rho) \setminus (M/id_M)\})$  and  $|\bigcup \{\Sigma_X; X \in (M/\rho) \setminus (M/id_M)\}| < m$  (by the regularity of  $m$ ) and so  $\rho$  is  $m$ -compact.

#### THEOREM 4.32.

*Let  $m$  be an infinite cardinal and  $\rho \in E(M)$ . Then  $\rho$  is  $m$ -compact if and only if for some regular  $n \leq m$  the following conditions hold:*

- i.  $|(M/\rho) \setminus (M/id_M)| < n$ ,*
- ii. For all  $X \in M/\rho$  we have  $|X| < n$ .*

#### PROOF

( $\Rightarrow$ ):) Take  $\rho$   $m$ -compact. If  $m$  is regular, by Lemma 4.31 we can take  $n = m$ . If  $m$  is singular, then by Lemma 4.30 there exists a regular  $n < m$  such that  $\rho$  is  $n$ -compact. Hence by Lemma 4.31(i) and (ii) hold for this  $n$ .

( $\Leftarrow$ ):) Suppose  $\rho$  satisfies (i) and (ii) for some regular  $n \leq m$ . Then by Lemma 4.31  $\rho$  is  $n$ -compact and as  $n \leq m$ ,  $\rho$  is  $m$ -compact also.

LEMMA 4.33.

Let  $\mathcal{T}$  be a local closure system on  $E(M)$  and let  $\sigma \in \mathcal{T}$ . Then  $\sigma$  is the  $\mathcal{T}$ -closure of an  $m$ -compact element of  $E(M)$  if and only if there is an infinite regular cardinal  $n \leq m$  such that the following conditions hold:

- i.  $|(M/\sigma) \setminus (M/\vartheta)| < n$ ,
- ii. For every  $X \in (M/\sigma)$  we have  $d_{\mathcal{T}}(X) < n$ .

PROOF

( $\Rightarrow$ ): Let  $\sigma = u_{\mathcal{T}}(\rho)$ , where  $\rho$  is an  $m$ -compact element of  $E(M)$ . Then, by Theorem 4.32, there exists an infinite regular cardinal  $n \leq m$  such that conditions (i) and (ii) of Theorem 4.32 hold. Condition (i) above is a consequence of Lemma 4.25 (iii), and condition (ii) above follows from Lemma 4.29 and from the regularity of  $n$ .

( $\Leftarrow$ ): Suppose  $\sigma$  satisfies both conditions (i) and (ii) above. For each  $X \in (M/\sigma) \setminus (M/\vartheta)$  take  $Y_X \subseteq X$  such that  $|Y_X| = d_{\mathcal{T}}(X)$  and such that  $\epsilon(X) = u_{\mathcal{T}}(Y_X^2 \cup id_M)$ . Then by Theorem 4.32, and the conditions (i) and (ii) above we have

$$\rho = id_M \cup \bigcup \{Y_X^2; X \in ((M/\sigma) \setminus (M/\vartheta))\},$$

is an  $m$ -compact element of  $E(M)$ . However, since  $\mathcal{T}$  is a local closure system,

$$\begin{aligned} u_{\mathcal{T}}(\rho) &= \bigcup \{u_{\mathcal{T}}(\rho \cap \epsilon(X)); X \in M/\sigma\} \\ &= \bigcup \{u_{\mathcal{T}}(Y_X^2 \cup id_M); X \in M/\sigma\} \\ &= \bigcup \{\epsilon(X); X \in M/\sigma\} \\ &= \sigma. \end{aligned}$$



THEOREM 4.34.

Let  $\mathcal{T}$  be an  $m$ -algebraic local closure system on  $E(M)$ , and let  $n$  be a cardinal such that  $\bar{m} \leq n$ . Then  $\sigma \in \mathcal{T}$  is an  $n$ -compact element of  $\mathcal{T}$  if and only if there is an infinite regular cardinal  $l \leq n$  such that the following conditions hold:

- i.  $|(M/\sigma) \setminus (M/\vartheta)| < l$ ,
- ii. For every  $X \in (M/\sigma)$  we have  $d_{\mathcal{T}}(X) < l$ .

PROOF

( $\Rightarrow$ ): Let  $\sigma \in \mathcal{T}$  be  $n$ -compact in  $\mathcal{T}$ . Then as  $E(M)$  is an  $m$ -algebraic lattice it follows from Theorem 2.31 that  $\sigma$  is the  $\mathcal{T}$ -closure of an  $n$ -compact element of  $E(M)$ . The result now follows from Lemma 4.33.

( $\Leftarrow$ ): It follows from Lemma 4.33 that  $\sigma$  is the  $\mathcal{T}$ -closure of an  $n$ -compact element of  $E(M)$ . But by Theorem 2.8, and the fact that  $\mathcal{T}$  is  $m$ -algebraic we have that  $\sigma$  is  $n$ -compact in  $\mathcal{T}$ .

REMARK 4.35.

We show that in general, the assumption of the  $m$ -algebraicity of  $\mathcal{T}$  cannot be omitted in Theorem 4.34: Let  $R$  be the real line and let  $S$  be the set of all closed intervals of  $R$ . Then  $S$  is a closure system on  $\exp R$  with property  $T_1$  and hence property  $P$ . Thus  $e(S)$  is a local closure system on  $E(M)$ , but it is easily verified that  $S$  is not an  $\omega$ -algebraic closure system on  $R$ . Take  $\sigma = id_R \cup [0, 1]^2 \in e(S)$ . For  $i = 2, 3, \dots$  define  $\sigma_i = id_R \cup [0, 1 - \frac{1}{i}]^2$ . Then for each  $i = 2, 3, \dots$ , we have  $\sigma_i \in e(S)$ . Now

$$\sigma = \bigvee_{e(S)} \{\sigma_i; i = 2, 3, \dots\},$$

and for each finite nonempty  $F \subseteq \{2, 3, \dots\}$  we have:

$$\sigma \neq \bigcup_{i \in F} \sigma_i = \bigvee_{e(S)} \{\sigma_i; i \in F\}.$$

Therefore  $\sigma$  is not an  $\omega$ -compact element of  $e(S)$ . Nevertheless,

$$|(R/\sigma) \setminus (R/id_R)| = 1,$$

and also

$$\text{for every } X \in R/\sigma \text{ we have } d_{e(S)}(X) \leq 2.$$

This shows that the assumption of the  $m$ -algebraicity of  $\mathcal{T}$  in Theorem 4.34 cannot be made weaker.

#### COROLLARY 4.36.

*Let  $m$  be regular and let  $S$  be an  $m$ -algebraic closure system on  $\exp M$  satisfying property  $P$ . Then  $\sigma \in e(S)$  is  $m$ -compact if and only if the following conditions hold:*

- i.  $|(M/\sigma) \setminus (M/\theta)| < m$*
- ii. For every  $X \in M/\sigma$  we have  $d_{e(S)} < m$ .*

#### PROOF

By Theorem 4.2,  $e(S)$  is  $m$ -algebraic and by Example 4.24,  $e(S)$  is a local closure system on  $E(M)$ . As  $m$  is regular we may now apply Theorem 4.34.

## NOTES ON REFERENCES

It is the aim of these notes to explain the relevance of the following list of references. Papers [6], [7], [8], [9], [10], [14], [15], [16], [17], [18], [19], [20] and [21] have been studied extensively to form the core of this thesis. However, almost all the results in these papers have been revised and adjusted to present a new viewpoint of this field. It is therefore unrealistic to acknowledge the authors of individual results and for this reason this note has been appended.

Chapter 0 makes use of [2], [3], [4], [5] and [11] to provide the terminology, notation and preliminary results required for the other chapters.

Chapter 1 looks at [21] from a different viewpoint in which the concept of  $m$ -compactness is replaced by the concept of weak  $m$ -compactness. The advantage of this is that elegant results arise for which the regularity/singularity of infinite cardinals do not have to be considered separately as in [21]. Preprint [7] is included in this chapter.

Chapter 2 is the analogue of Chapter 1. This chapter looks at [17], [18], and [21] presenting the counterexamples for the various results of Chapter 1 that do not follow through for  $m$ -compactness where  $m$  is singular.

Chapter 3 summarises [16]. However, the definition of an  $m$ -Tulipani closure operator has been adjusted to yield the definition of a weak  $m$ -Tulipani closure operator. This coincides with the trend of Chapters 1 and 2. Theorem 3.12 is a stronger version of Theorem 3.13 which is proved only for the regular case in [18].

Chapter 4 describes and summarises certain relevant results from [8] and [9].

All the other references listed in the table of references have been studied to

provide the background knowledge pertaining to this field of study.

REFERENCES

- [1] G.Birkhoff: *Lattice theory*. AMS 1967.
- [2] S.Burris and H.P.Sankappanavar: *A course in universal algebra*. Springer-Verlag, New York-Heidelberg-Berlin, (1981).
- [3] B.A.Davey and H.A.Priestly: *Introduction to lattices and order*. Cambridge University Press, Great Britain, 1990.
- [4] G.Grätzer: *Universal algebra*. 2nd edition, Springer-Verlag, New York-Heidelberg-Berlin, 1979.
- [5] G.Grätzer: *General lattice theory*. Birkhäuser Verlag, Basel and Stuttgart, 1978.
- [6] O.Jordens: *Closure operators on compactly generated lattices*, 1994, Preprint.
- [7] O.Jordens: *On closure operators preserving compactness or accessibility*, 1994, Preprint.
- [8] O.Jordens and T.Sturm: *Equivalences with closed equivalence classes*. Math. Japonica, 36 (1991), 291-304.
- [9] O.Jordens and T.Sturm: *Closure systems of equivalences with a local property*. Math. Japonica, 36 (1991), 245-250.
- [10] B.Kutinová and T.Sturm: *On algebraic closures of compact elements*. Czechoslo-

vak Math. J. 29 (1976), 359-365.

[11] A.Levy: *Basic set theory*. Springer-Verlag, Berlin-Heidelberg-New York, (1979).

[12] R.N.McKenzie, G.F.McNulty and W.F.Taylor: *Algebras, lattices, varieties*. Wadsworth and Brooks, Monterey, California, (1987).

[13] E.C.Milner and M.Pouzet: *On the cofinality of partially ordered sets*. I.Rival (ed.), *Ordered Sets*, (1982), 279-298.

[14] M.Mogambery and T.Sturm: *On  $\kappa$ -compact elements of boolean algebras*. (To be published) (1994).

[15] A.Rutkowski and T.Sturm: *A note on the least upper bound in the partially ordered set*. *Demonstratio Math.* 17 (1984), 79-84.

[16] J.Ryšlinková: *On  $m$ -algebraic closures of  $n$ -compact elements*. *Comment. Math. Univ. Carolinae*, 19 (1978), 743-759.

[17] J.Ryšlinková: *The characterisation of  $m$ -compact elements in some lattices*. *Czechoslovak Math. J.* 29(1979), 252-267.

[18] J.Ryšlinková and T.Sturm: *Two closure operators which preserve  $m$ -compactity*. *Banach Center Publ.* 9 (1982), 113-119.

[19] T.Sturm: *On the lattice of kernels of isotonic mappings*. *Czechoslovak Math. J.* 27 (1977), 258-295.

[20] T.Sturm: *Lattices of convex equivalences*. *Czechoslovak Math. J.* 29 (1979),

396-405.

[21] T.Sturm: *Closure operators which preserve the m-compactness*. Boll. Un. Mat. Ital. (6) 1-B (1982), 197-209.

[22] T.Sturm: *Lecture notes in universal algebra*. Dept. of Math., UND, (1988).

[23] S.Tulipani: *Alcuni risultati sui reticoli m-algebraici*. Ann.Univ, Ferrara Sez. VII, 16 (1971), 55-62.

INDEX Of DEFINITIONS

<u>TERMINOLOGY</u>	<u>PAGE</u>
(m-)accessible	14
(m-)algebraic closure operator	13
(m-)algebraic closure system	13
(m-)algebraic lattice	61
atom	4
$C_m(L)$	42
$C_m(u[L])$	42
$C(m, x, L)$	42
$C(m, x, u[L])$	42
chain	4
closed under reconstruction	79
closure operator	6
closure system	6
cofinality	3
(m-)compact	39
(m-)compact preserving	41
comparable	4
complete	5
cover relation	4
directed	10
(m-)directed	19
$d_T(X)$	95
$E(M)$	1
$e(S)$	78
equivalence class of $x$ modulo $\sigma$	1
(order) filter	3
(principal) filter	3
(order) ideal	3
(principal) ideal	3
identity relation	2
(m-)inaccessible	15
incomparable	4
infimum	4
lattice	5
local closure system	91