

STUDIES OF SOME NEW EUPHORBIACEAE DITERPENES

A thesis submitted in partial fulfilment of the  
requirements for the degree of Doctor of Philosophy  
in the Department of Chemistry, University of Natal.

by

Joan Margaret McGarry M.Sc. (Natal)  
University of Natal,  
Durban.

June, 1971.

(1)

DECLARATION

I hereby certify that this research is the result of my own investigation, which has not already been accepted in substance for any degree, and is not being concurrently submitted in candidature for any other degree.

Signed... *J. M. McGarry* .....  
J. M. MCGARRY

I hereby certify that the above statement is correct.

Signed... *H. A. Candy* .....  
H. A. CANDY M.Sc. (S.A.)  
Supervisor

Department of Chemistry,  
University of Natal,  
Durban.

ACKNOWLEDGEMENTS

I would like to express my sincere appreciation to Dr. K. H. Pegel for his guidance, encouragement and many helpful discussions during the course of this research.

In addition I wish to express my thanks to the following:-

Mr. H. A. Candy for his supervision and helpful criticism of this work.

Dr. S. H. Eggers for mass spectra and accurate mass measurements.

Dr. K. H. Pachler for n.m.r. spectra.

Dr. P. R. Enslin for o.r.d. curves.

Dr. J. W. W. Morgan for samples of isopimara-8(14),15-dien-3 $\beta$ -ol, isopimara-8(14),15-dien-3-one and isopimara-8(14),15-diene.

My husband, Dr. E. J. McGarry, for his encouragement, many helpful discussions and reproduction of spectra.

The South African Council for Scientific and Industrial Research for a research grant in 1967.

The South African Association of University Women for the Bertha Stoneman Memorial Award for Botanical Research in 1968.

SUMMARY

The heartwoods of two species of South African Euphorbiaceae have been chemically investigated.

From Cleistanthus schlechteri three new diterpenes possessing the hitherto unknown ent-isopimara-8(14),15-diene skeleton were isolated. By means of chemical and spectroscopic methods these were shown to be 3 $\alpha$ -hydroxy-ent-isopimara-8(14),15-diene, I, 3 $\alpha$ -hydroxy-ent-isopimara-8(14),15-dien-12-one, II, and 3 $\alpha$ ,12 $\alpha$ -dihydroxy-ent-isopimara-8(14),15-diene, III. A biogenetic sequence has been proposed in which it is suggested that these compounds are probably the precursors of the major diterpenoid, cleistanthol, IV, previously isolated from this source.

From the second species, Spirostachys africana, a new diterpenoid seco-acid, spirostachic acid, VIII, was obtained in addition to the beyerene derivatives previously reported. Mass spectral fragmentation patterns of the seco-acid and its methyl esters proved to be useful as a diagnostic tool in structure elucidations.



CONTENTS

INTRODUCTION	1
PRESENT INVESTIGATIONS	
Part 1. The Diterpenes of <u>Cleistanthus schlechteri</u>	31
1.1 3 $\alpha$ -Hydroxy- <u>ent</u> -isopimara-8(14),15-diene, I	31
1.2 3 $\alpha$ -Hydroxy- <u>ent</u> -isopimara-8(14),15-dien-12-one, II	71
1.3 3 $\alpha$ ,12 $\alpha$ -Dihydroxy- <u>ent</u> -isopimara-8(14),15-diene, III	97
Part 2. The Diterpenes of <u>Spirostachys africana</u>	110
2.1 Beyer-15-en-3-one, V, 3-Hydroxybeyer-15-en-2-one, VI, and 2-Hydroxybeyer-1,15-dien-3-one, VII	112
2.2 Spirostachic acid or 2,3-Secobeyer-15-en-2,3-dioic acid, VIII	112
Conclusion	132
Experimental	133
Part 1. <u>Cleistanthus schlechteri</u>	136
Part 2. <u>Spirostachys africana</u>	154
Reference Abbreviations	163
References	166

## INTRODUCTION

The Euphorbiaceae which constitutes one of the largest and most widely distributed plant families has provided a source of interesting compounds for chemical investigation. This thesis is concerned with the isolation and characterisation of some new diterpenes obtained from two species indigenous to Southern Africa.

The first and major section of this work deals with pimarane-type diterpenes isolated from the heartwood of Cleistanthus schlechteri (PAX) HUTCH. var. schlechteri, while the second section describes a beyerene (stachene)-type diterpene obtained from the heartwood of Spirostachys africana Sond. (syn. Excoecaria africana Muell. Arg.).

It will be shown that the three new diterpenes present in Cleistanthus schlechteri are 3 $\alpha$ -hydroxy-ent-isopimara-8(14),15-diene, I, 3 $\alpha$ -hydroxy-ent-isopimara-8(14),15-dien-12-one, II, and 3 $\alpha$ ,12 $\alpha$ -dihydroxy-ent-isopimara-8(14),15-diene, III, congeners of the major constituent cleistanthol, IV, whose structure was recently elucidated (1,2,3).

The heartwood of Spirostachys africana has been the subject of a number of investigations. Earlier studies (4,5) revealed that the heartwood contained an oleoresin, but it was only in 1962 that three of the main diterpenoid constituents were characterised as being the ketone, V, named stachenone, the  $\alpha$ -ketol, VI, and the diosphenol, VII (6,7). During a renewed investigation of the light

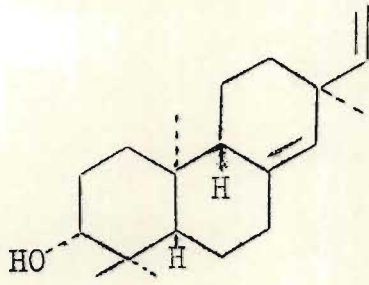

I

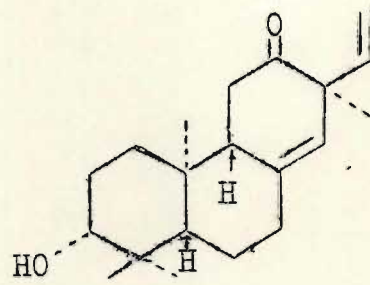

II

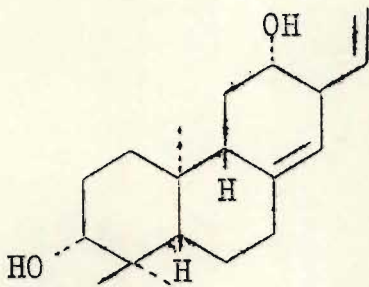

III

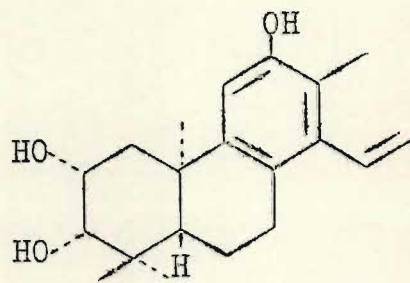

IV

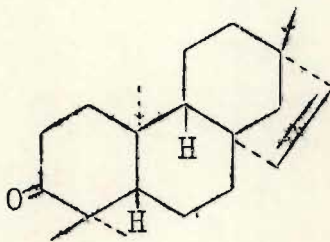

V

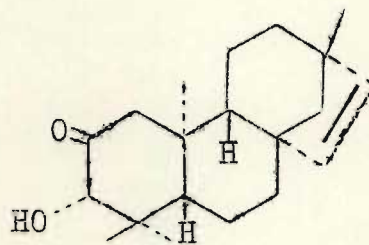

VI

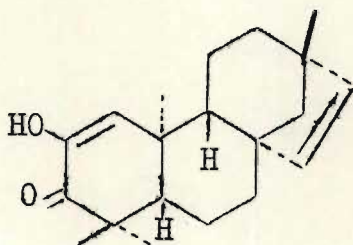

VII

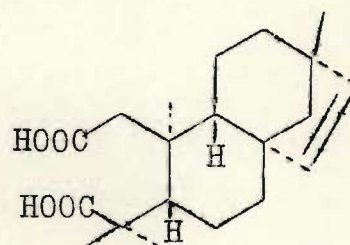

VIII



petroleum extracts of the heartwood a new diterpenoid, named spirostachic acid was isolated and evidence leading to its formulation as VIII will be presented.

### THE DITERPENOIDS

It is only in the past two decades with the advent of chromatographic and physical methods allowing for the purification and characterisation of naturally occurring compounds that outstanding advances have been made in the field of diterpenoid chemistry. Expansion has been so rapid that it is necessary to provide a background to the progress which has taken place, although many reviews have been written on the subject (8,9,10,11,12,13). Particular attention will be paid to diterpenoids isolated from the Euphorbiaceae family and the results of their investigation will be discussed in detail.

The diterpenoids comprise a widespread group of compounds which are found mainly in plant resins. They are derived essentially from the union of four isoprene units to yield compounds containing twenty carbon atoms, thereby satisfying the Biogenetic Isoprene Rule (14).

A number of basic polycyclic skeletons are now recognised, but only a relevant few are illustrated (Figure 1) showing the nomenclature and numbering system employed. The numbering of carbon atoms is based on that of the steroid convention for rings A and B and not on the



FIGURE 1. SOME BASIC DITERPENOID SKELETONS

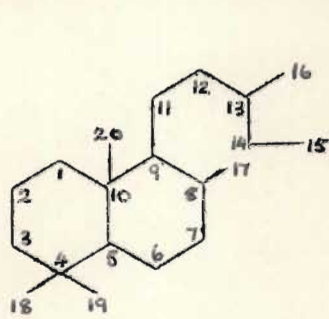

(a) Labdane

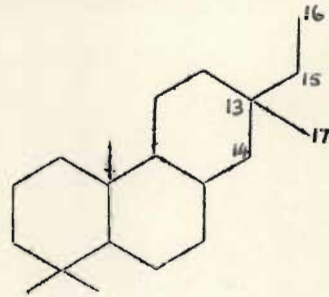

(b) Pimarane

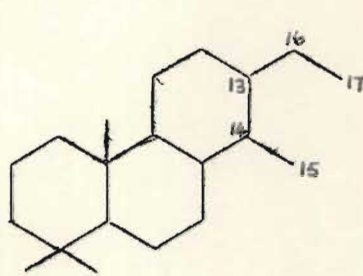

(c) Cassane

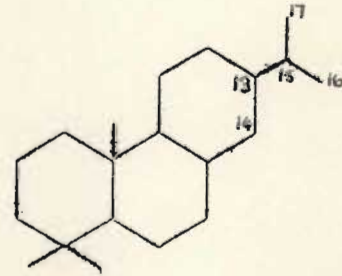

(d) Abietane

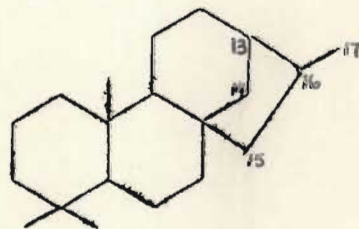

(e) Kaurane

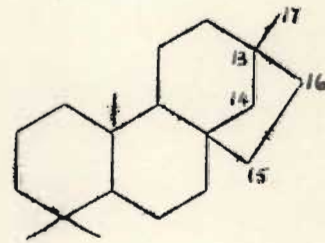

(f) Beyerane or Stachane

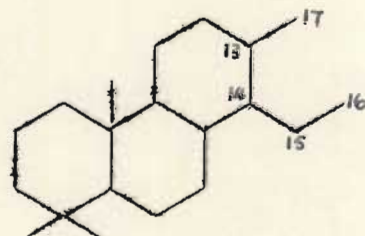

(g) Cleistanthane

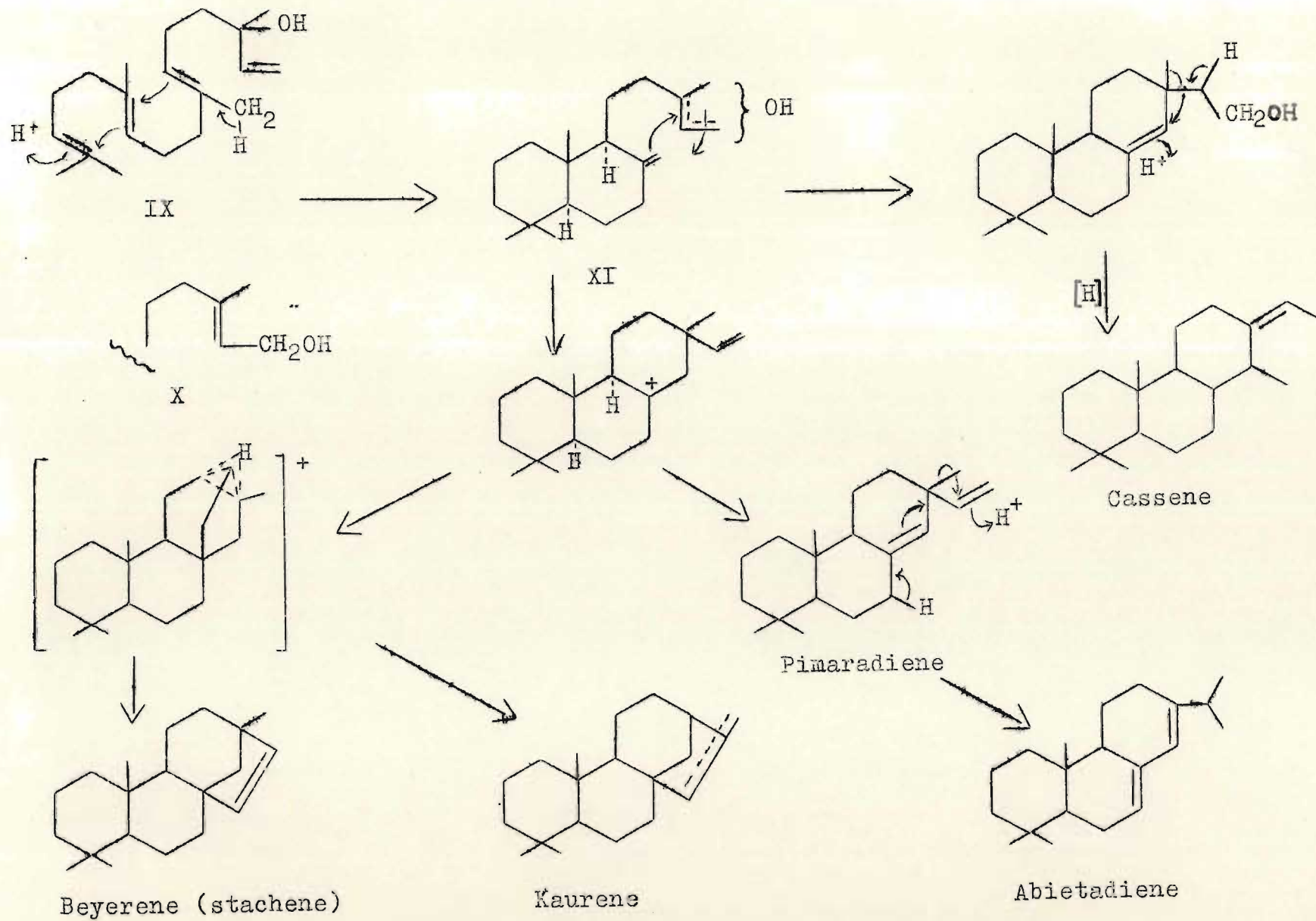

**FIGURE 2 BIOGENESIS OF SOME DITERPENOIDS**

phenanthrene skeleton as was previously the case (13). The C-4 equatorial substituent is numbered 18 and the C-4 axial substituent, 19.

All di-, tri-, tetra- and pentacarbocyclic diterpenoids may be derived in principle from geranyl-geraniol, IX, or geranyl-linaloöl, X, via the intermediate bicyclic alcohol, XI, of the labdane type. Hence the parent skeletons shown in Figure 1 are readily synthesised through a common biogenetic pathway as outlined in Figure 2. A possible biosynthetic sequence leading to the new cleistanthane skeleton will be discussed at the conclusion of the section on Cleistanthus schlechteri.

#### DITERPENOIDS OF THE LABDANE TYPE

The evidence concerning the structures of manool, XII, sclareol, XIII, and manoyl oxide, XIV, all of which have the normal labdane skeleton, has been adequately summarised (15,16,17).

Although there had been a large degree of uncertainty over the absolute stereochemistry at C-13 in manool, XII, and sclareol, XIII, direct configurational correlation was achieved (18) by the conversion of sclareol into the lactone of  $\gamma$ -hydroxy- $\gamma$ -methylhexanoic acid, XV, which could also be derived from R(-)-linaloöl, XVI.

The stereochemistry of manoyl oxide, XIV, at C-8 was confirmed by its hydrogenolysis to 8-hydroxy-labd-13-



ene, XVII, (19) while the assignment at C-13 was based on the comparison of fragmentation patterns in the mass spectra of manoyl oxide and its 13-epi compound, XVIII.

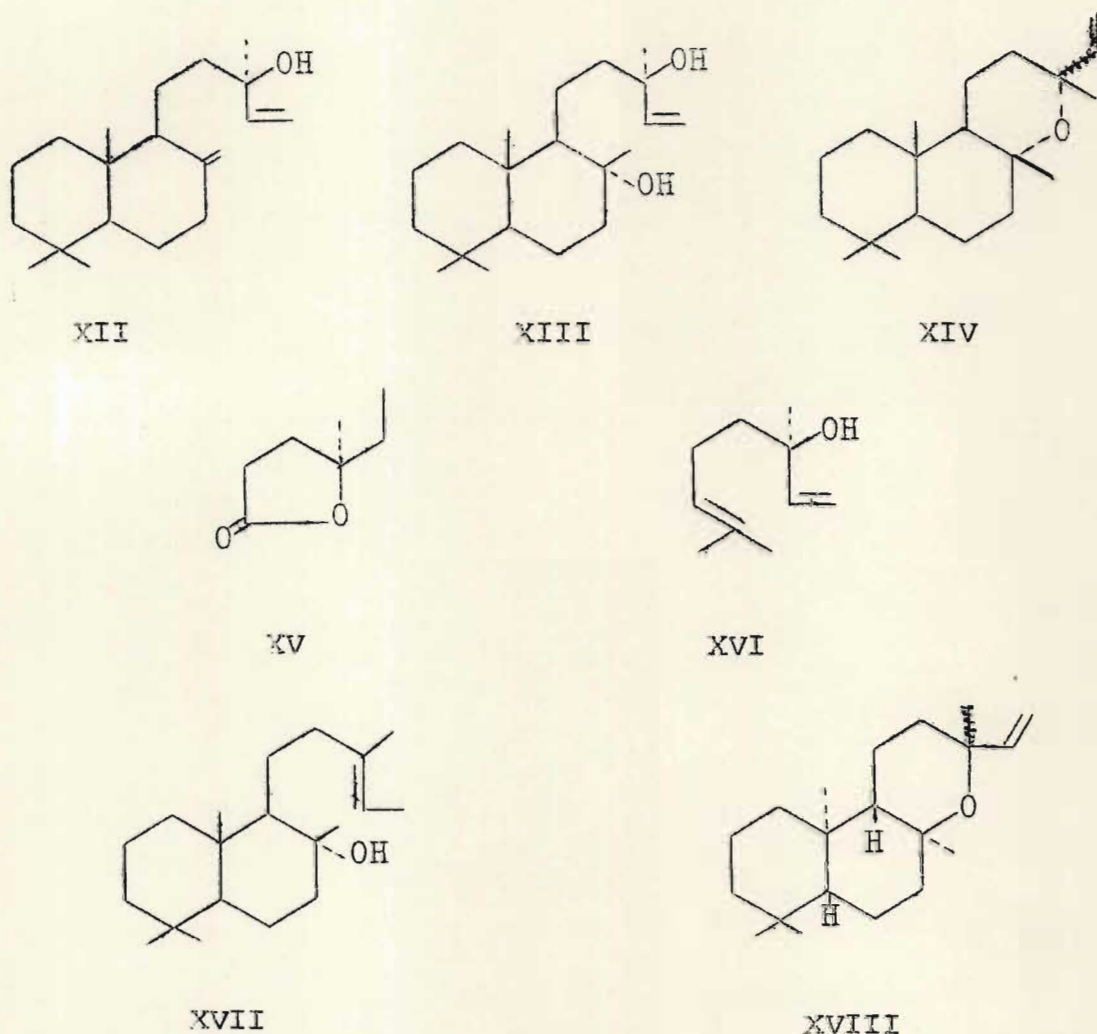

The occurrence of similar compounds has been reported in some species of Euphorbiaceae. During the investigation of Ricinocarpus muricatus (20,21) a number of bicyclic diterpenes of the labdane type were isolated and found to be related to eperuic acid, XIX, which was shown to be antipodal to labd-8(20)-en-15-oic acid, XX, at all its asymmetric centres except C-13 (22). The diterpenes



characterised were eperuane-8 $\beta$ ,15-diol, XXI, eperuane-8 $\beta$ , 15,18-triol, XXII, 15,16-dihydroxyeperu-8(20)-en-18-oic acid, XXIII, eperu-8(20)-en-15,18-dioic acid, XXIV, 15-hydroxyeperu-8(20)-en-18-oic acid, XXV, and the  $\Delta^{\alpha\beta}$ -butenolide, XXVI.

The resin acids of Ricinocarpus stylosus were reported to contain the bicarbocyclic polyalthic acid, XXVII, (23,24,25) besides four new tetracyclic diterpenes which are discussed in a later section.

From a new species of Beyeria a further four bicarbocyclic diterpenes were isolated and their structures formulated as the diol, XXVIII, the alcohol, XXIX, the acid, XXX, and the known 13 epi-(-)-manoyl oxide, XVIII (26).

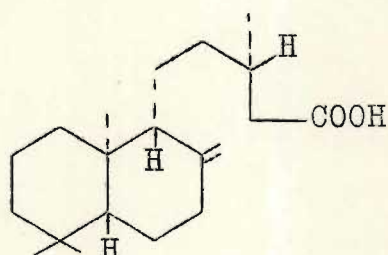

XIX

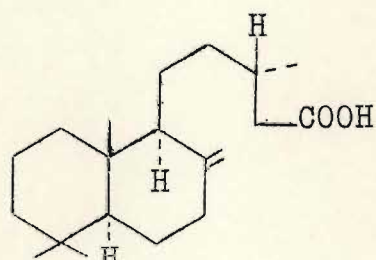

XX

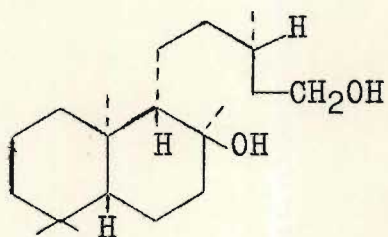

XXI

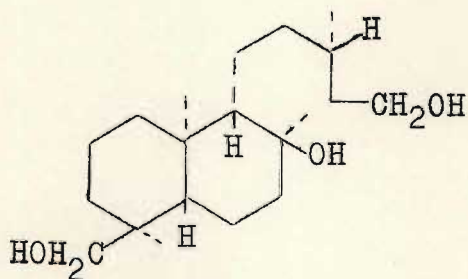

XXII

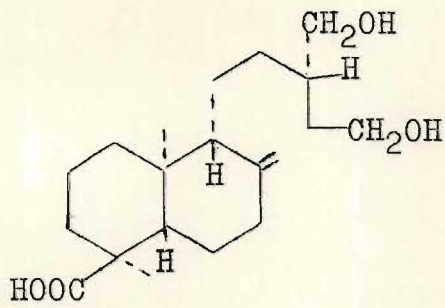

XXIII

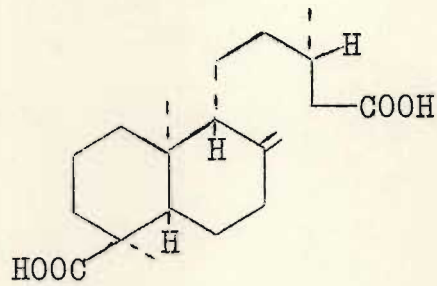

XXIV

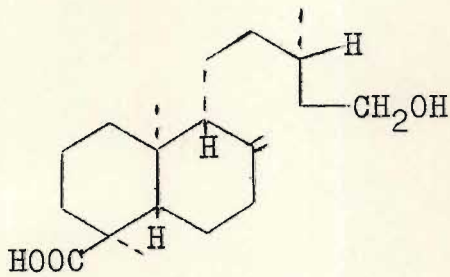

XXV

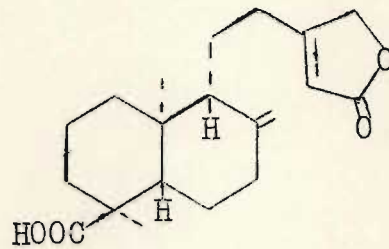

XXVI

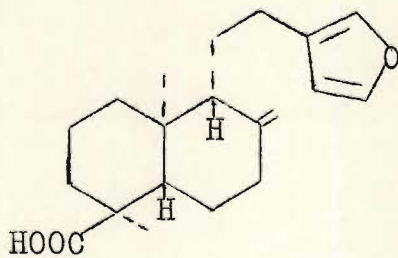

XXVII

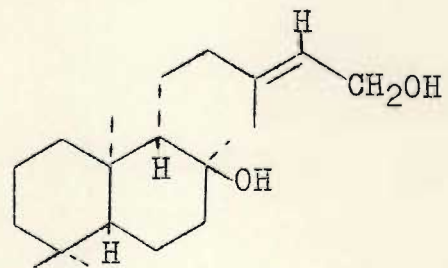

XXVIII

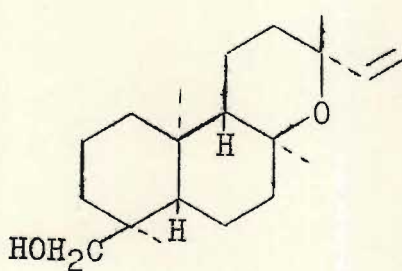

XXIX

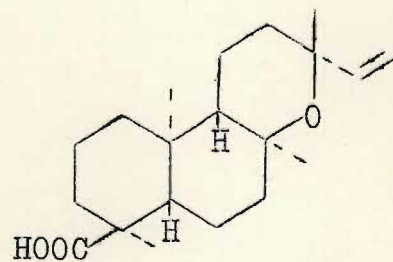

XXX

An epoxy-furanoid diterpene obtained from the bark of Croton eleuteria (Cascarilla bark) was called cascarillin A and for which the structure XXXI was proposed (27). X-Ray analysis was performed on deacetylcascarillin acetal iodoacetate and this allowed its structure and absolute stereochemistry to be established as shown in XXXII (28). From these investigations the previous structure proposed for cascarillin (29), the bitter principle of Cascarilla bark was revised to XXXIII.

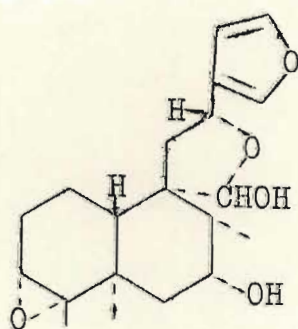

XXXI

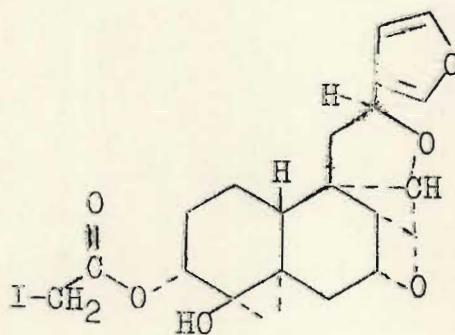

XXXII

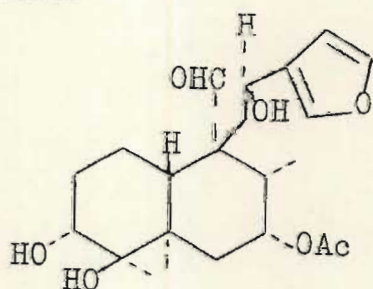

XXXIII

#### DITERPENOIDS OF THE PIMARANE TYPE

In order to eradicate the confusion caused by the use of a variety of common names for some of the well-



known resin acids e.g. sandaracopimaric and isopimaric acids, a system of nomenclature has been proposed in which the basic skeletons are pimarane, XXXIV (a), and isopimarane, XXXIV (b), which differ only in their stereochemistry at C-13. This system will be adhered to throughout this thesis to maintain uniformity and promote a better understanding of the compounds under discussion.

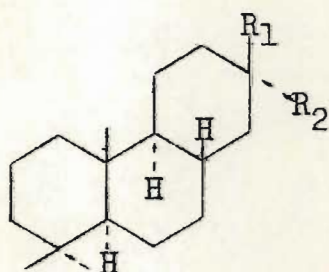

	R <sub>1</sub>	R <sub>2</sub>
XXXIV (a)	Et	Me
(b)	Me	Et

The resin acids - pimara-8(14),15-dien-19-oic acid, XXXV, (pimaric acid), isopimara-8(14),15-dien-19-oic acid, XXXVI, (sandaracopimaric acid) and isopimara-7,15-dien-19-oic acid, XXXVII, (isopimaric acid) - have been the subject of many investigations since the isolation of both XXXV and XXXVII from the oleoresin acids of Pinus palustris (30). They were shown to possess the same configurations at three of the five asymmetric centres (31) whilst the stereochemistry at C-9 and C-13 was left open to speculation.

By an acid-catalysed lactonisation of the 15,16-dihydro derivatives of these acids (32) the asymmetry at C-9 was destroyed and an infrared study of the products revealed a small difference between them. This was taken



to indicate that the two acids therefore differed in their stereochemistry at C-13. Furthermore, after examining the yield ratios of the equilibrated lactones it was suggested that XXXV had its bulkier substituent axially orientated i.e. the  $13\beta$ -configuration (32).

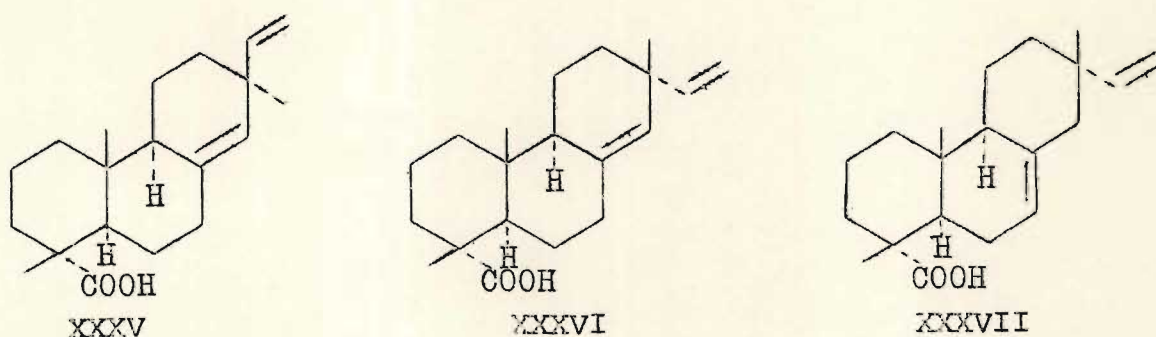

Independent researchers (33) confirmed the epimeric relationship at C-13 in both the resin acids, XXXV and XXXVII, while other investigators (34,35,36,37,38,39,40) favoured the idea that the compounds were also epimeric at C-9.

Edwards et al (41,42) then established by chemical correlation and optical rotatory dispersion data that the acid, XXXVI, was a C-13 epimer of XXXV. Furthermore, the synthesis of pimara-8(14),15-diene, XXXVIII, and isopimara-8(14),15-diene, XXXIX, and their comparison by means of gas-liquid chromatography with dienes derived from the corresponding acids substantiated the structures, XXXV and XXXVI, proposed for the acids (43,44).

Since the acids, XXXVI and XXXVII, were both

epimeric with XXXV at C-13, but not identical to each other, the difference was ascribed to their configurations at C-9. However, it was shown that XXXVII conformed to the expected trans-anti-trans system of fusion by its conversion into 13,13-dimethylpodocarpane, XL (45), and thus possessed a C-9  $\alpha$ -hydrogen. This suggested that XXXVII was not a C-9 epimer, but rather a double bond isomer of XXXVI.

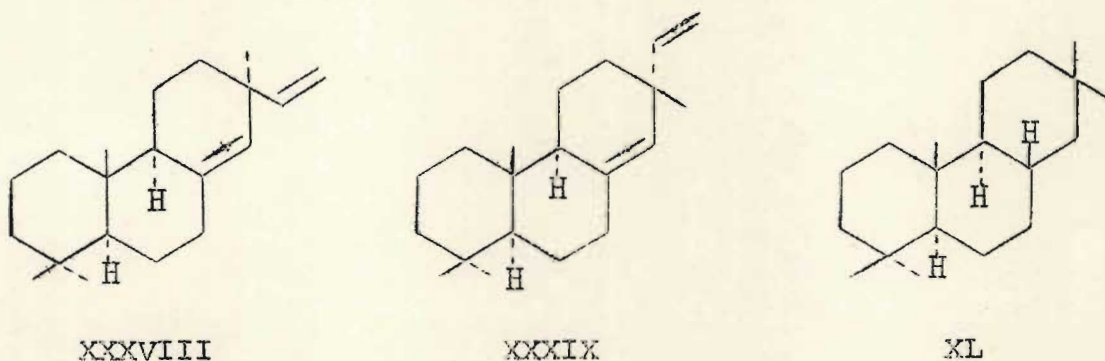

The stereospecific syntheses of Ireland et al (44,46,47) determined beyond doubt the C-7, C-8 position of the double bond in XXXVII and also defined the stereochemistry at C-13 in all three acids. They served to verify the conclusions put forward earlier (32) that pimara-8(14),15-dien-19-oic acid, XXXV, possesses 13 $\alpha$ -methyl and 13 $\beta$ -vinyl substituents, and hence both XXXVI and XXXVII have the antipodal location of these groups.

Further chemical and optical rotatory dispersion evidence obtained by Edwards et al (48) also confirmed that isopimara-7,15-dien-19-oic acid could only be represented by structure XXXVII.

Investigations performed on the hydrogenation products of the pimaric acids indicated that the fully



reduced derivatives posed another interesting stereochemical problem, this time at C-8. The relevant compounds are pimarane-19-oic acid, XLI (a), and isopimarane-19-oic acid, XLI (b).

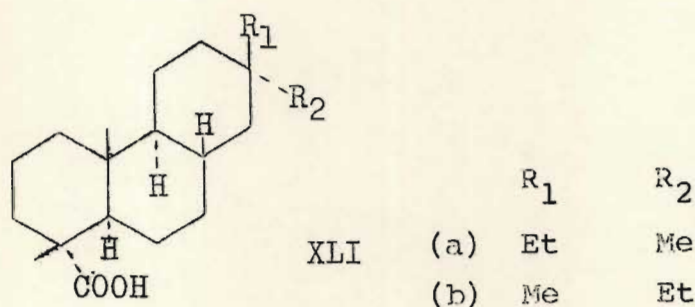

It had been discovered that during the hydrogenation of XXXV the nuclear double bond underwent migration to the  $\Delta^{8,9}$  position before being fully reduced over a platinum oxide catalyst in glacial acetic acid medium (33). On the basis of the commonly accepted concept that addition of hydrogen occurs from the less hindered side of an unsaturated molecule in a cis fashion the general prediction was that the tetrahydro derivatives would have trans-anti-cis fused backbones i.e. the hydrogen at C-8 would be  $\alpha$ -orientated. This configuration was in fact assigned to a tetrahydro pimaric acid produced on hydrogenation under pressure at an elevated temperature (49) and which possessed a melting point lower than that obtained by hydrogenation under normal conditions. Other workers (50, 51) have shown the higher melting derivative to possess the more stable trans-anti-trans configuration in which the

C-8 hydrogen would be  $\beta$ -orientated. The latter assignment was supported by n.m.r. evidence.

A similar chemical investigation performed on XXXVI and XXXVII caused the conclusion to be drawn that all the tetrahydro pimaric acids which had been obtained under standard conditions of hydrogenation possessed trans-anti-trans fused skeletons.

It had been proposed (52) that the hydrocarbon rimuene could be represented by the same structure as isopimara-8(14),15-diene, XXXIX, but this theory was shown to be erroneous by comparison of the two compounds (43). By means of chemical, spectrographic and synthetic research it has been conclusively proved that rimuene is not a  $\Delta^{8(14),15}$ -pimaradiene, but has the structure and stereochemistry as shown in XLII (53,54,55).

The partial synthesis of rimuane, XLIII, was instrumental in determining the absolute stereochemistry at every asymmetric centre, and hence in rimuene as well (56,57).

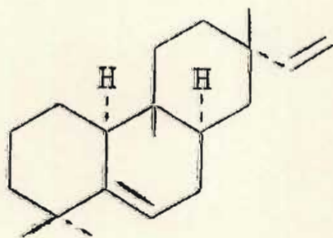

XLII

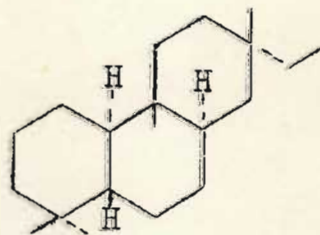

XLIII



A recent survey of the literature has revealed that only a few diterpenoids of the pimarane type have been isolated from the Euphorbiaceae.

From a species endemic to Western Australia, Beyeria brevifolia, a new acid was obtained and characterised as (15S)-15,16-dihydroxy-3,4-seco-ent-pimara-4(18),7-dien-3-oic acid, XLIV, (58). Its structure was assigned on the basis of extensive n.m.r. data and the conversion of the acid into 3,4-seco-beyerane, XLV, which was partially synthesised. The seco-acid was the first example of a bi-carbocyclic diterpenoid to be found in any species of Beyeria, which are better known for their tetracyclic diterpenoid constituents.

Three new diterpenes have been isolated from Croton oblongifolius L, an Indian species of Euphorbiaceae. The most recently reported (59a) compound, oblongifolic acid, has been formulated as (+)isopimara-7,15-dien-19-oic acid, XLVI (a), while the earlier congeners named oblongifoliol and deoxyoblongifoliol (59b,59c) are now considered to be structures, XLVI (b) and XLVI (c) respectively, rather than the C-8(14) double bond and C-13<sub>a</sub>-vinyl isomers previously postulated.

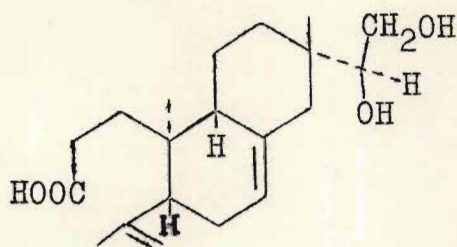

XLIV

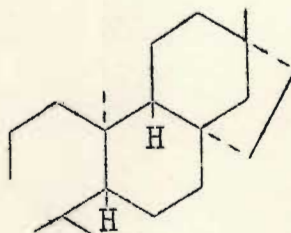

XLV

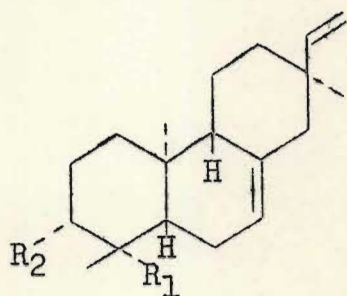

XLVI

	R <sub>1</sub>	R <sub>2</sub>
(a)	COOH	H
(b)	CH <sub>2</sub> OH	OH
(c)	CH <sub>3</sub>	OH

### DITERPENOIDS OF THE KAURANE AND BEYERANE TYPES

It is generally accepted that tetracyclic diterpenoids arise by cyclisation of members of the pimarane series (60). In particular cyclisation of pimara-8(14),15-diene, XXXVIII, may proceed via a carbonium ion intermediate illustrated in the scheme below, to produce either of two similar diterpenoid skeletons viz. hibaene, XLVII and kaurene, XLVIII (61,62).

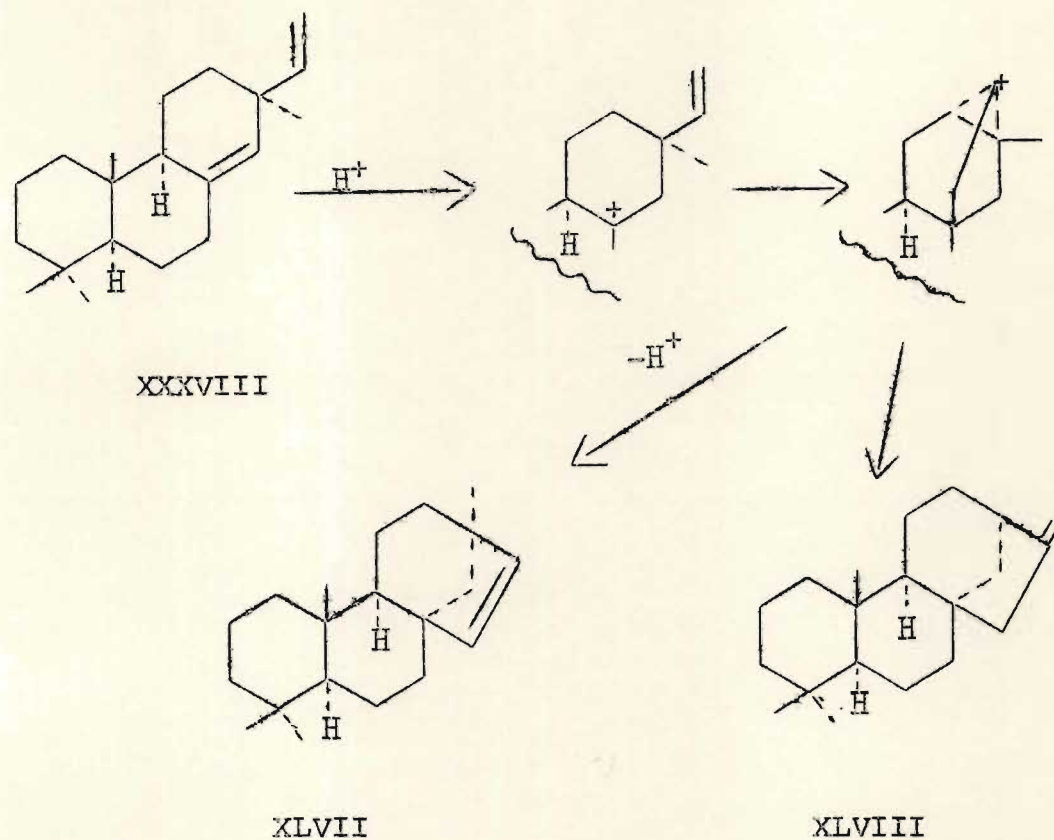

The structure proposed (63) for hibaene was confirmed by its total synthesis performed by Ireland et al (64). The relationship between hibaene and kaurene prompted an investigation into the possibility of their chemical interconversion. First attempts involved the conversion of isopimara-7,15-diene, XLIX, into isohibaene, L, by means of hydroboration and oxidation-reduction reactions. A consideration of steric requirements and n.m.r. studies of the synthetic intermediates established that isohibaene, L, was indeed the C-8, C-13 epimer of hibaene, XLVII (62).



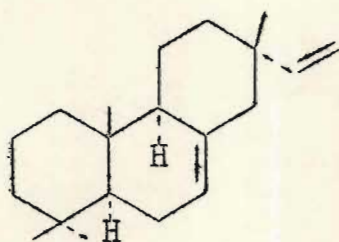

XLIX

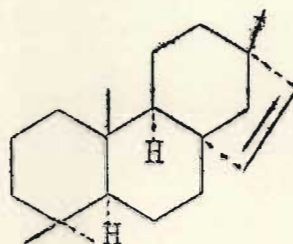

L

At this stage the presence of two hibaene-like diterpenes were reported in two species of Euphorbiaceae. A ketone called stachenone was isolated from the oleoresin of *Spirostachys africana* Sond. (7) and assigned the structure V, but no distinction was specified between the possible C-9 and C-8, C-13 isomers. A close study of the n.m.r. data and the chemical conversion of stachenone, V, to the hydrocarbon beyerene (stachene), LI, proved this compound to be enantiomeric with hibaene, XLVII (62).

Horn et al also reported (7) the presence of two more diterpenoids possessing the same hydrocarbon skeleton and formulated their structures as VI and VII.

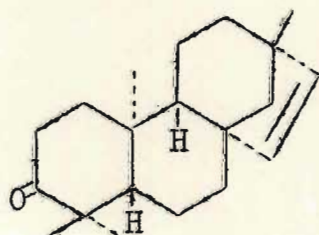

V

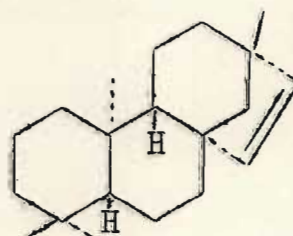

LI

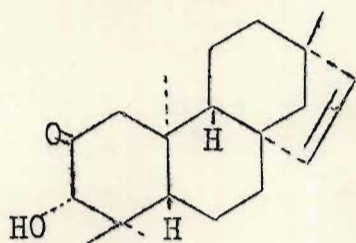

VI

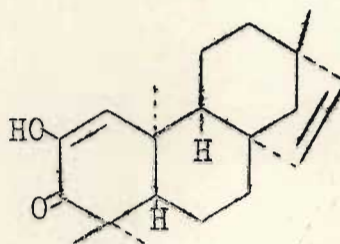

VII

An Australian Euphorbiaceae, Beyeria leschenaultii (DC) Baill. var. drummondii (Muell. Arg.) was shown to contain a diterpenoid mono-cinnamate as its major constituent (65). Alkaline hydrolysis of the substance yielded a trihydroxy diterpene named beyerol, LII, whose structure and stereochemistry was elucidated by Jefferies et al (66). Thus the names stachene and beyerene refer to the same hydrocarbon skeleton, LI.

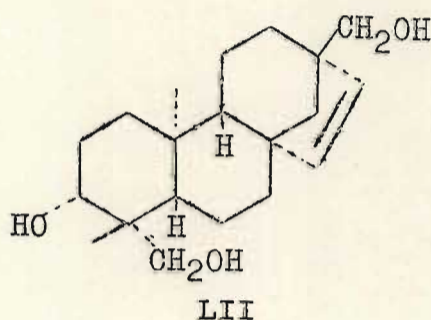

LII

Subsequently, a systematic survey of Beyeria and other allied Australian genera was conducted. Ether extraction of the leaves of a shrub tentatively identified as Beyeria brevifolia (Muell. Arg.) Benth. afforded an hydroxy keto-acid, an acetoxy-keto-acid and a triol. These natural products were shown to be diterpenes possessing,



in contrast to beyerol, the  $16\alpha$ -(-)-kaurane [( $-$ )- $\beta$ -dihydrokaurane] skeleton, LIII (62,65,66). By means of selective manipulation of the three oxygenated functions evidence was accumulated which allowed the structures and stereochemistry of the above-mentioned diterpenes to be formulated as LIV (a), LIV (b) and LV respectively (67).

Further examination of ether-soluble neutral compounds isolated from Beyeria leschenaultii (68) revealed the presence of the known triol, LV, together with a new diterpene shown by its relationship with the triol to be ( $-$ )-kaur-16-en-3 $\alpha$ ,19-diol, LVI.

Concurrent with the work on Beyeria species the hard resin coating of Ricinocarpus stylosus Diels was examined (23,24,25,69). Besides the bicyclic polyalthic acid, XXVII, four new kauranoid diterpenes were isolated. They were identified as  $16\alpha$ -(-)-kauran-17,19-dioic acid, LVII (a), 19-hydroxy- $16\alpha$ -(-)-kauran-17-oic acid, LVII (b), ( $-$ )-kauran- $16\alpha$ ,17,19-triol, LVIII and ( $-$ )-kaur-16-en-19-oic acid, LIX.

Further results obtained on investigation of another species of Beyeria (70) disclosed the presence of a number of bicarbocyclic diterpenoids mentioned earlier and some tetracarbo-cyclic constituents. Two of the latter had been encountered in Ricinocarpus stylosus (69) and identified as LVIII and LIX, while the third compound, LV, had previously been reported from two species of Beyeria (67,68). The three new kaurane derivatives were formulated



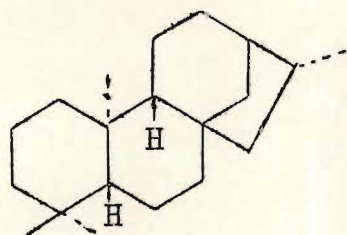

LIII

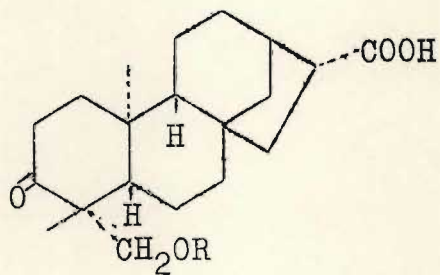

LIV

(a) R = H

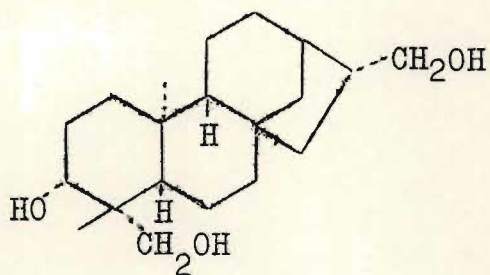
(b) R = COCH<sub>3</sub>

LV

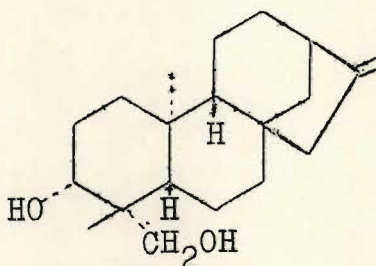

LVI

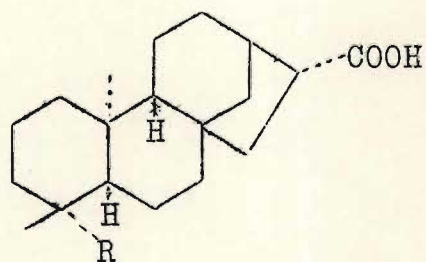

LVII

(a) R = COOH

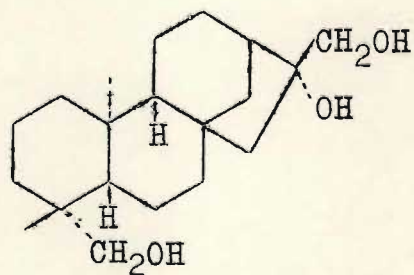
(b) R = CH<sub>2</sub>OH

LVIII

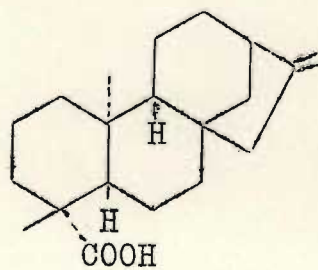

LIX

as the diol, LX (a), the hydroxy acid, LX (b) and the dihydroxy acid, LXI.

During the continued investigation of the acidic components present in Ricinocarpus stylosus Diels two further (-)-kaurane derivatives were identified (71). One was the known 16,17-dihydroxy-16-(-)-kauran-19-oic acid, LXI, first isolated from a Beyeria sp. nov. (70). The unknown acid proved to be the first example of a 1 $\alpha$ -hydroxy-(-)-kaurane derivative (72) and an examination of the chemical and n.m.r. data indicated that the compound was in fact 1 $\alpha$ ,19-dihydroxy-16 $\alpha$ -(-)-kauran-17-oic acid, LXII.

The acidic fraction of the ether extract of a Beyeria sp. nov. on silicic acid chromatography yielded a secobeyerene (73) which was characterised as 17-hydroxy-3,4-secobeyer-4(18),15-diene-3-oic acid, LXIII. This was the first reported natural occurrence of the 3-carboxy-3,4-seco system in the diterpene series.

Yet another three diterpenes were isolated from the leaf resin of a different variety of Beyeria leschenaultii (74). Two of the substances were new and possessed the beyer-15-ene skeleton while the third was the previously reported 3,4-secobeyerene, LXIII. The major constituent was a keto acetoxy alcohol whose structure was elucidated as LXIV, while the remaining diterpene was formulated as LXV.

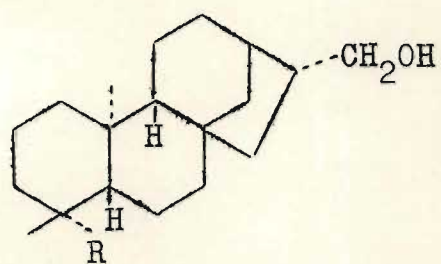

LX (a)  $R = \text{CH}_2\text{OH}$   
 (b)  $R = \text{COOH}$

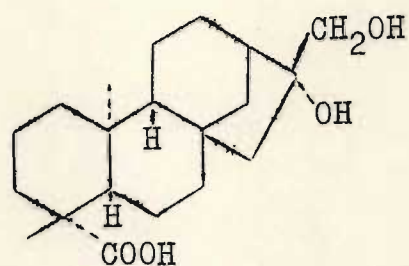

LXI

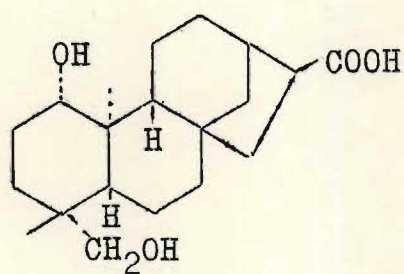

LXII

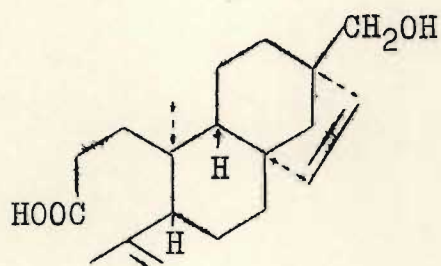

LXIII

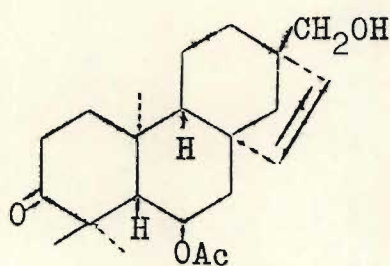

LXIV

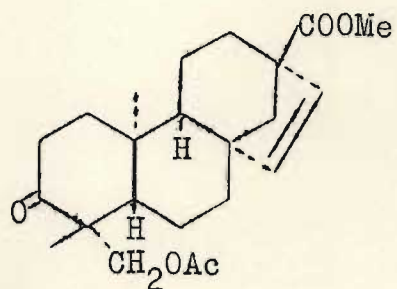

LXV



Beyeria latifolia, a species which abounds in the southerly districts of Western Australia was found to contain three new diterpenes of the (-)-kaurane type (75). Their structures were established as  $16\beta$ -(-)-kaurane- $3\alpha,16,17,19$ -tetrol, LXVI,  $16\beta$ -(-)-kaurane- $3\alpha,16,19$ -triol, LXVII and  $16\beta$ -(-)-kaurane- $3\alpha,16,17$ -triol, LXVIII, the latter two being isolated as their acetates.

The diterpenes LXVI and LXVIII were also found to occur in Beyeria leschenaultii together with the known kaurane derivatives, LVII (b) (69) and LX (b) (70). The structure of a new diterpene which had been isolated as its methyl ester was deduced to be  $12\beta,17$ -dihydroxy- $16\alpha$ -(-)-kauran-19-oic acid, LXIX (76).

Examination of the leaf resin of Beyeria brevifolia (Muell. Arg.) Benth. was continued (67) and yielded the known diterpenes beyerol, LII (62,66) and  $16,17$ -dihydroxy- $16\beta$ -(-)-kauran-19-oic acid, LXI (70), besides a new seco-ent-pimarane diterpenoid, XLIV, mentioned in the previous section.

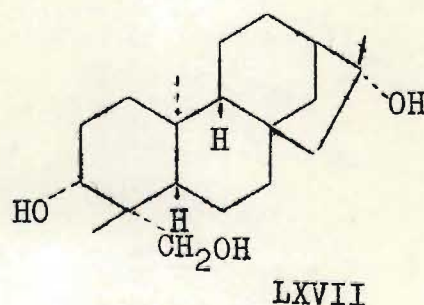
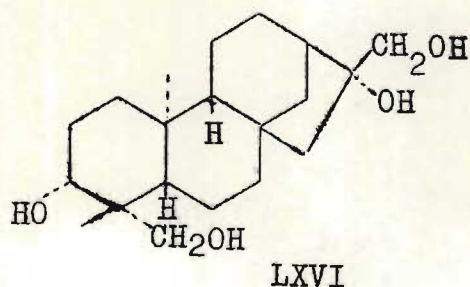

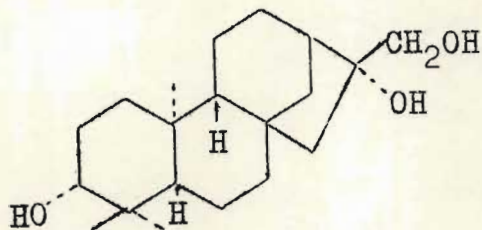

LXVIII

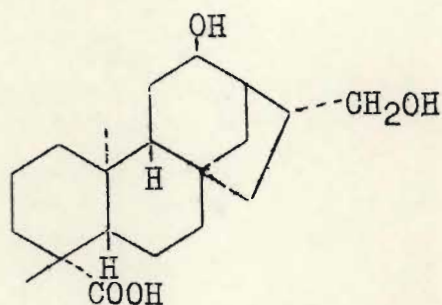

LXIX

The predominance of such a large number of diterpenoids of the (-)-kaurane series in particular, and of the beyerene type in so many Australian species of Euphorbiaceae prompted an attempt at the interconversion of the two skeletons (77). (-)-Kaurene, LXX, itself undergoes partial isomerisation under acid conditions to give iso-kaurene, LXXI, without any skeletal rearrangements taking place (69,78), but 3 $\alpha$ ,19-ethylidenedioxy-beyer-15-ene, LXXII, on acid treatment either failed to rearrange or resulted in a complex mixture.

A chemical sequence was then devised in which oxygen was introduced into the C-15 and C-16 positions by means of hydroboration (66) of the beyerene, LXXII, and the corresponding 17-hydroxy compound, LXXIII. The ketones so formed on lithium aluminium hydride reduction yielded the 15-exo isomeric alcohol, LXXIV (a) and the 15 $\beta$ ,17-diol, LXXV, respectively. Assignment of the configurations was based on the close correspondence of molecular rotation differences in the derivatives of both the 15-oxygenated and the 15,17-dihydroxy compounds.



Reduction of the epoxide of the beyerene, LXXII, with lithium in ethylamine produced a mixture of isomeric alcohols, LXXIV (a) and LXXIV (b). Tosylation of the latter followed by treatment with sodium acetate and acetic acid yielded a hydrocarbon fraction containing the beyerene, LXXII, and the (-)-kaurene, LXXVI. This fraction was successfully chromatographed to furnish 3 $\alpha$ ,19-ethylidene-dioxy-(-)-kaur-15-ene, LXXVI thereby proving possible the interconversion of the beyerene and (-)-kaur-15-ene skeletons.

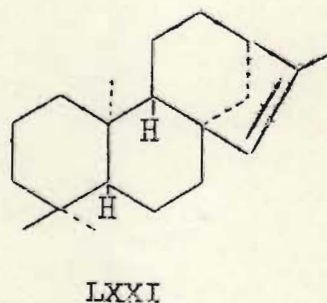
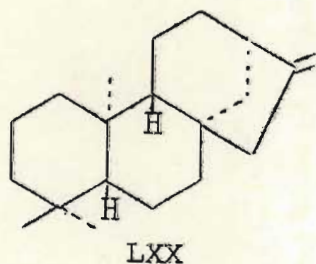

The frequent occurrence of kaurane-type diterpenoids found in many Australian species of Euphorbiaceae overshadows the number of beyerane-type diterpenes which have been isolated from the same family. Since it has been shown that a chemical conversion from beyerene to kaurene is possible it seems feasible that such a pathway is followed biosynthetically in the plant. In such an event it is possible that diterpenoids of the (-)-kaurane series constitute one of the major end products of biogenesis.

In contrast investigations performed on a



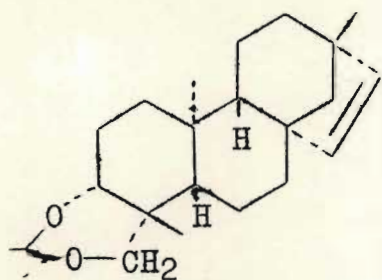

LXXII

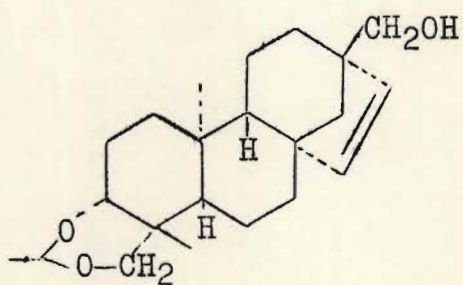

LXXIII

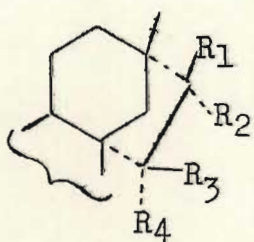

LXXIV

	R <sub>1</sub>	R <sub>2</sub>	R <sub>3</sub>	R <sub>4</sub>
(a)	H	H	OH	H
(b)	OH	H	H	H

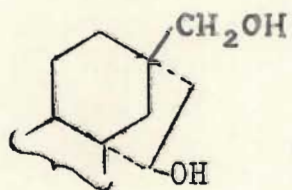

LXXV

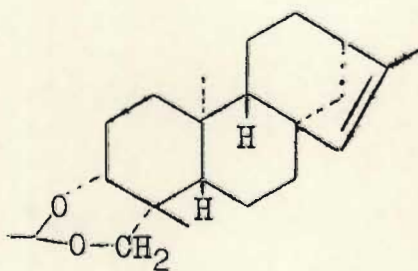

LXXVI

limited number of South African Euphorbiaceae have provided little correlation of hydrocarbon skeletons, and furthermore no kauranoid diterpenes have been encountered. The stachene type compounds isolated from Spirostachys africana are, in fact, diterpenoids with the beyerene skeleton, but the pimarenoids to be discussed have not previously been reported in any other Euphorbiaceae.

#### OXYGENATION PATTERNS

As is commonly found in triterpenoid and steroid series an increasing number of diterpenoids have been reported to possess oxygen functions at C-3. This is especially true in the case of diterpenes isolated from the Euphorbiaceae.

The degree of oxidation at this position ranges from a hydroxyl group which is predominantly present in the *d*-configuration as in beyerol, LII, to a keto grouping as in the kauranoid ketone, LIV (a) and to an acid as in the seco-beyerene, LXIII.

However, only one example of oxygenation at the C-1 position has been reported, viz. the kaurenoid, LXII, while the ketol, II, is but the second example of oxygenation at C-12 in alicyclic diterpenes, the first being another kauranoid, LXIX. Oxygenation often occurs at the C-19 position usually in the form of a secondary hydroxyl or acid grouping, but it appears that oxygen functions at

C-7, C-11 or C-14 have yet to be encountered in the Euphorbiaceae diterpenes.

STEREOCHEMISTRY OF THE A/B RING JUNCTION

A characteristic feature of all the Euphorbiaceae diterpenoids is that they possess A/B trans ring fusions in which the C-5 hydrogen is in the  $\beta$ -configuration and the C-10 methyl group in the  $\alpha$ -configuration.

This conforms to the usual A/B trans fused rings found in the triterpenoid series with the conspicuous difference that all the triterpenes isolated from this family possess the opposite but "normal"  $5\alpha,10\beta$ -stereochemistry common to naturally-occurring triterpenoids.



PRESENT INVESTIGATIONSPART 1. THE DITERPENES OF CLEISTANTHUS SCHLECHTERI

Cleistanthus schlechteri (PAX) HUTCH. variety schlechteri (family Euphorbiaceae) is a small tree which grows to a height of about thirty feet. It is found growing in the coastal forests of Zululand and extends northwards through East Africa to Kenya (79). The tree has a characteristic grey, longitudinally grooved bark and possesses a light yellow sapwood with a clearly defined, attractive tan-coloured heartwood.

Studies were confined to the heartwood which appeared to provide the highest yields of constituents for chemical investigation. Extracts were obtained by soaking the milled, air-dried wood overnight at room temperature in light petroleum. These extracts, after concentration, were combined and furnished a viscous orange syrup from which the three major components were separated as crystalline products by means of column chromatography. A thin layer chromatogram revealed that these compounds were all less polar than the known diterpene cleistanthol, IV, previously isolated from the hot light petroleum extract.

1.1 3 $\alpha$ -Hydroxy-ent-isopimara-8(14),15-diene, I.

The least polar (and least abundant) of the three

compounds isolated has been identified as 3 $\alpha$ -hydroxy-ent-isopimara-8(14),15-diene, I.

Preliminary colour reactions gave very little indication of the class of compound under investigation. No colour was produced under the conditions for the Liebermann-Burchard test for triterpenes (80) and no detectable colour change was observed on the addition of a neutral ferric chloride solution to a methanolic solution of the substance, thereby suggesting the absence of phenolic or enolic hydroxy groups. The characteristic yellow colouration which developed when a few crystals were treated with tetranitromethane was indicative of at least one olefinic double bond (81).

The molecular formula, C<sub>20</sub>H<sub>32</sub>O established by elementary analysis and mass spectrometry indicated the diterpenoid character of the compound, which was not surprising in view of the previously reported isolation of cleistanthol, IV, from the same source (1,2,3).

#### The Oxygen Function

The infrared spectrum of the diterpene, I, (Figure 3) (in potassium bromide) displayed a broad hump around 3325 cm.<sup>-1</sup> indicating the presence of an hydroxy group. In general, the free O-H stretching frequencies of alcohols in solution are found in the region between 3650-3500 cm.<sup>-1</sup> (82). Thus the low frequency of absorption in



the spectrum of I implied some degree of intermolecular hydrogen bonding and polymerisation as expected for the solid state (82).

The other absorptions associated with alcohols are the O-H bending vibration, which usually occurs in the region from 1400-1300  $\text{cm}^{-1}$  (83,84), and the C-OH stretching vibration which is generally found between 1205-1050  $\text{cm}^{-1}$  (85). It has been shown that hydrogen bonding increases the frequency of the former absorption, and thus in the spectrum of I this band appeared at 1475  $\text{cm}^{-1}$ . The latter absorption has been used to assign the configuration of hydroxy groups in the steroid and triterpenoid series (86, 87,88). However, as these bands occurred at 1045 and 1100  $\text{cm}^{-1}$  it was not possible to determine the axial or equatorial configuration of the hydroxy group.

Acetylation of the diterpene, I, with acetic anhydride in pyridine afforded a monoacetate, LXXVII, which was shown by elementary analysis and mass spectrometry to have the formula  $\text{C}_{22}\text{H}_{34}\text{O}_2$ . The infrared spectrum of this acetate was similar to that of the parent alcohol except for the disappearance of the hydroxy bands and the appearance of an intense absorption at 1712  $\text{cm}^{-1}$  due to the acetate carbonyl group and another at 1240  $\text{cm}^{-1}$  arising from the ester C-O linkage.

This evidence established that the compound under investigation was a diterpene alcohol.



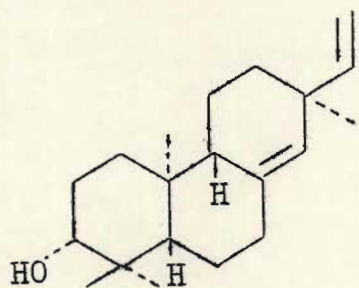

I

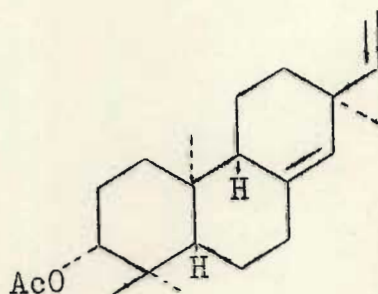

LXXVII

### The Double Bonds

The positive tetranitromethane test had already indicated the presence of at least one olefinic double bond. A study of the C-H stretching region near  $3000\text{ cm.}^{-1}$  in the infrared spectrum of the alcohol, I, proved valuable in determining the nature and degree of substitution of the double bond(s). Investigations have shown (89) that stretching vibrations of compounds containing  $\text{RHC}=\text{CH}_2$  groups are found in the regions  $3095\text{--}3075$  and  $3040\text{--}3010\text{ cm.}^{-1}$ . The former band has been assigned to the terminal methylene group and the latter to the  $=\text{CHR}$  group. A weak band at  $3080\text{ cm.}^{-1}$  in the spectrum (Figure 3) was consistent with the presence of a terminal methylene group, but the lower frequency band was not detected as it was probably obscured by the intense saturated C-H absorptions.

The second region associated with unsaturation is that due to the C=C stretching vibration which is found between  $1680\text{--}1620\text{ cm.}^{-1}$  (90). These bands are usually weak but terminal double bonds absorb more strongly than those

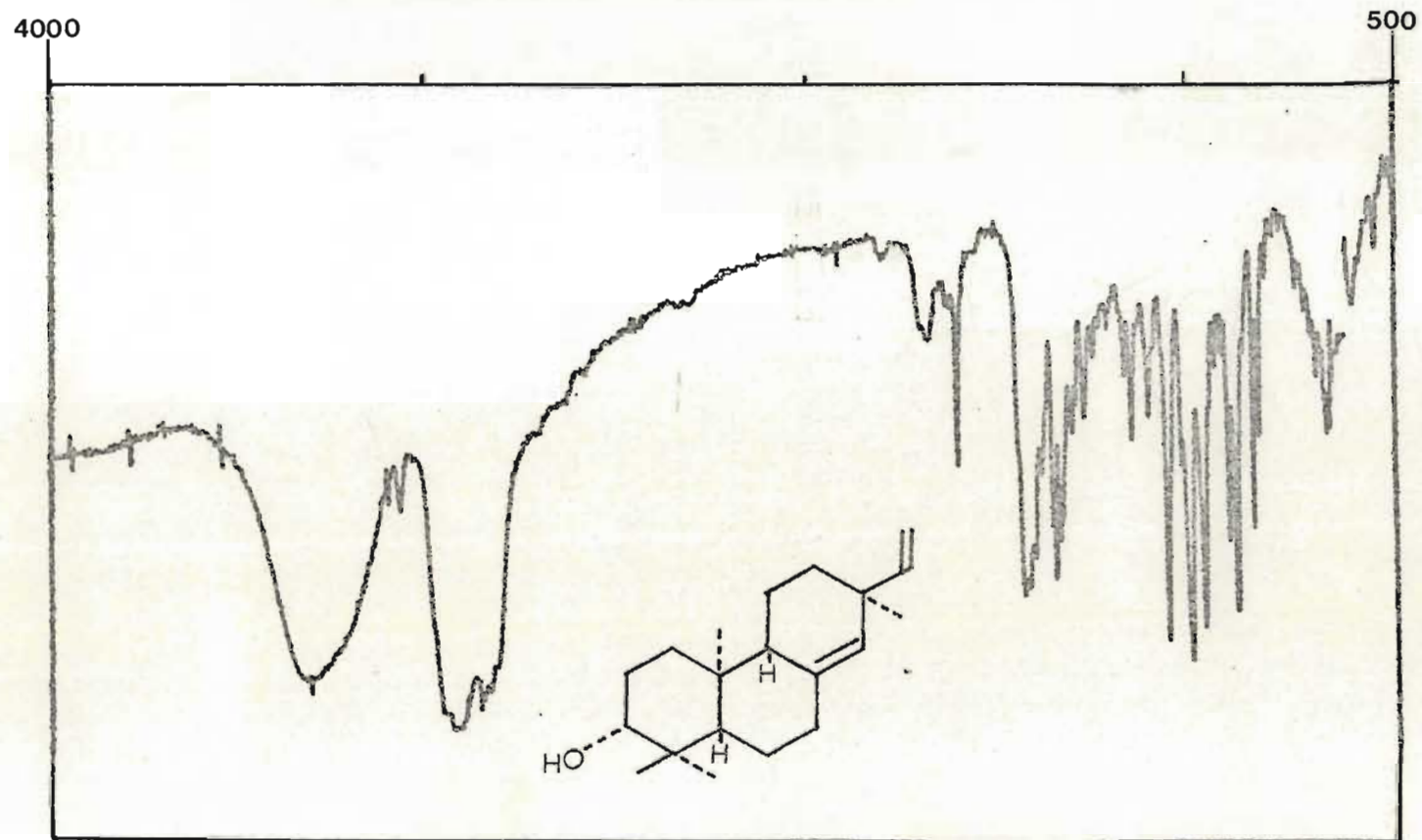
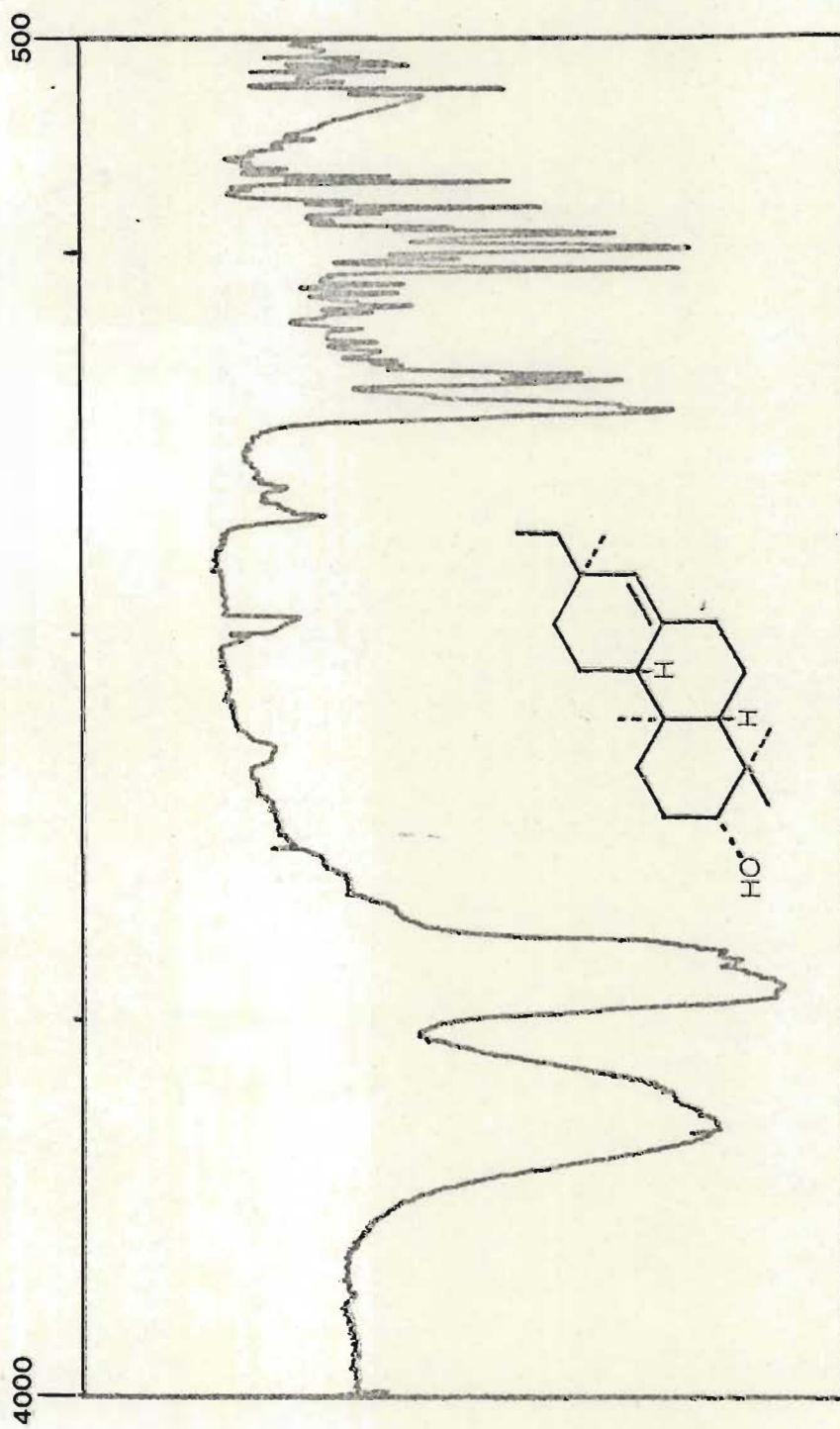

FIGURE 3 IR SPECTRUM OF 3 $\alpha$ -HYDROXY-*ent*-ISOPIMARA-8(14),15-DIENE .

FIGURE 4 IR SPECTRUM OF 3 $\alpha$ -HYDROXY-ent-ISOPINANE-8(14)-ENE



within a ring. In the spectrum of I, a moderately strong band appeared at  $1631\text{ cm.}^{-1}$ . The intensity of this band was consistent with a double bond being located outside a ring system.

In order to determine quantitatively the number of olefinic linkages in the alcohol, I, the compound was hydrogenated over a palladium on carbon catalyst in ethanolic medium at room temperature and atmospheric pressure. This resulted in the rapid uptake of one mole of hydrogen to give the 15,16-dihydro derivative, LXXVIII (a), whose molecular formula was shown to be  $\text{C}_{20}\text{H}_{34}\text{O}$  by elementary analysis. In the infrared spectrum of this compound (Figure 4) the band at  $3080\text{ cm.}^{-1}$  was absent while the band at  $1631\text{ cm.}^{-1}$  underwent a marked decrease in intensity. This evidence implied that the terminal double bond had been reduced while a second double bond (probably endocyclic because of the low intensity of the band at  $1631\text{ cm.}^{-1}$ ) remained.

Acetylation of the dihydro derivative yielded the acetate  $\text{C}_{22}\text{H}_{36}\text{O}_2$ , LXXVIII (b) whose infrared spectrum was very similar to that of the parent acetate, LXXVII. It did confirm, however, the absence of the absorption at  $3080\text{ cm.}^{-1}$  but the band at  $1631\text{ cm.}^{-1}$  was obscured by the intense acetate carbonyl absorption.

Hydrogenation of the alcohol, I, over Adam's catalyst in glacial acetic acid resulted in the rapid uptake of one mole of hydrogen as previously observed, but a subsequent slow absorption of hydrogen continued.

Prolonged hydrogenation (24 hrs.) failed to produce a pure tetrahydro derivative, but hydrogenation at 100 atmospheres and room temperature afforded the pure tetrahydro alcohol,  $C_{20}H_{36}O$ , LXXIX. The infrared spectrum of this compound displayed no absorptions attributable to double bonds, thereby confirming that the alcohol was fully saturated. This therefore proved that the parent alcohol, I, contained only two double bonds. The configuration of the C-8 hydrogen was not investigated, but by analogy with the results observed during the study of the tetrahydro-pimaric acids by ApSimon *et al* (50) it would be expected to be in the  $\alpha$ -configuration so as to produce a product with the trans-anti-trans fused skeleton.

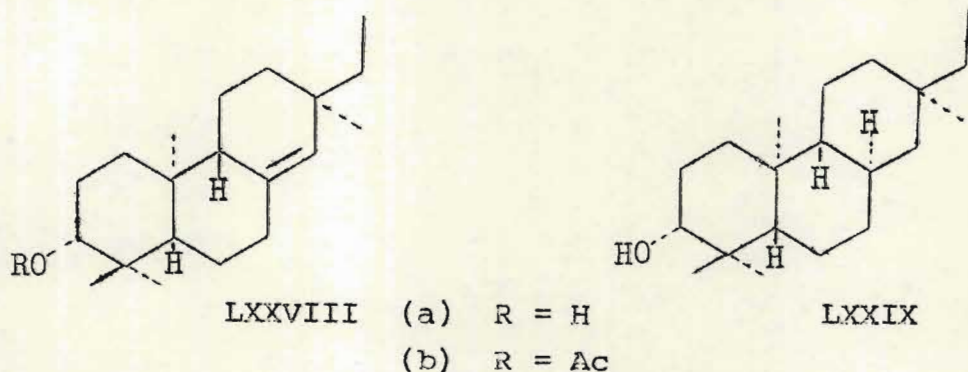

### Ultraviolet Spectra

The ultraviolet absorption spectra of the alcohol, I, and its derivatives did not exhibit any characteristic bands in the region above 210 nm. thereby establishing that the two double bonds discussed above were not in conjugation.



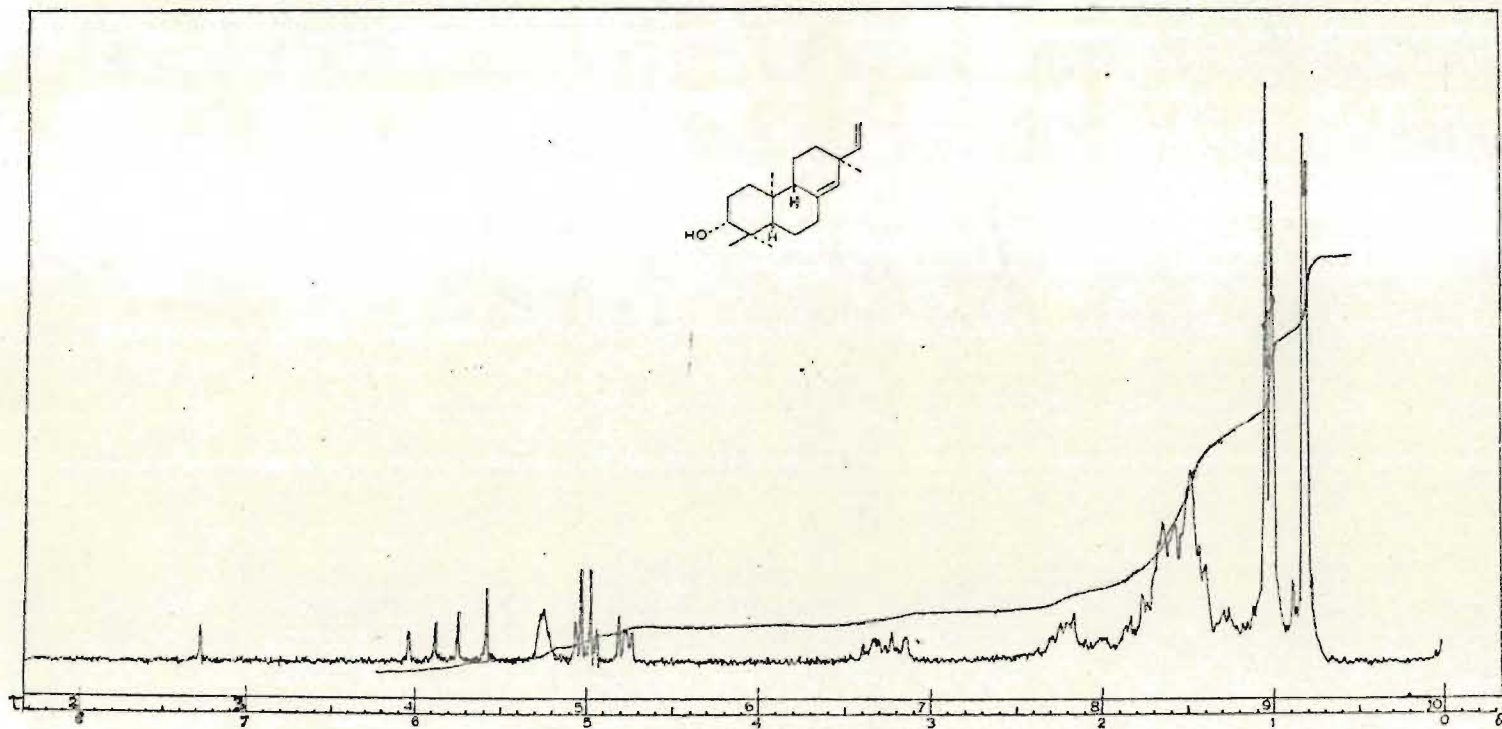

FIGURE 5 NMR SPECTRUM OF 3 $\alpha$ -HYDROXY-ent-ISOPIMARA-8(14),15-DIENE



Nuclear Magnetic Resonance Spectra

The n.m.r. spectrum of the alcohol, I, proved most informative in the determination of the basic skeleton, the nature of the substituent groups, positions of unsaturation and the configuration of the hydroxy group.

The spectrum (Figure 5) exhibited a quartet of lines centred at  $\tau$ 4.19 due to one proton. This signal was attributed to the C-15 hydrogen atom which forms the X part of an ABX system, LXXX, in which the two non-equivalent C-16 protons of the vinyl group constitute the AB portion and resonate as a complex multiplet centred at  $\tau$ 5.10. It has been determined that the trans-olefinic coupling constant is usually greater than the cis-olefinic coupling constant, and in the case of I the observed coupling constants were  $J_{AX}=18$  Hz and  $J_{BX}=10$  Hz (91). The geminal coupling constant was small (observed  $J_{AB}=1.5$  Hz) as expected when the angle ( $\theta$ ) between the protons is relatively large (about  $120^\circ$ ). This is in agreement with the relationship postulated by Karplus (92,93) that the value of the coupling constant  $J$  for geminate protons decreases from about 20 Hz at a dihedral angle of  $105^\circ$  to 0 at a dihedral angle of  $125^\circ$ .

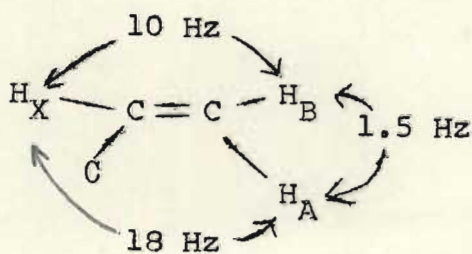

LXXX

A broad signal at  $\tau$  4.75 was assigned to the olefinic proton at C-14. It occurred as a slight doublet with an observed coupling constant of  $J=2$  Hz which may be attributable to allylic coupling with the axial C-9 proton. It has been established by empirical correlation that allylic coupling is greatest when the angle between the olefinic and allylic protons lies between  $60^\circ$ - $110^\circ$  (94,95). A study of a model of the alcohol, I, revealed that the angle between the C-14 and C-9 protons was approximately  $90^\circ$  and thus the observed coupling constant is in agreement with the theoretically predicted value.

The one proton multiplet at  $\tau$  6.73 was ascribed to the C-3 hydrogen atom adjacent to the hydroxy moiety. Again this proton may be theoretically regarded as the X portion of an ABX system, but the observed splittings indicated that coupling was not of the first order. The usual position for the signal due to such protons is between  $\tau$  5.5-6.5, but it has been found that an axial proton attached to a hydroxy substituted carbon atom resonates at higher field than in the corresponding epimeric situation (96). The position of this signal in the spectrum of I was consistent with the C-3 proton being axially orientated i.e. the hydroxy group was in the equatorial configuration. Furthermore, such an axial proton would be subjected to a large diaxial and a small axial-equatorial vicinal coupling which would lead to a broadening of the signal. In Figure 5 the broad pattern of splitting with



a half-band width of approximately 14 Hz served as a further indication that the C-3 proton was axially orientated.

The methylene envelope extended from  $\tau$ 7.8-8.7, but no specific assignments could be made. Four strong signals due to the C-13, C-4 equatorial, C-4 axial and C-10 methyl groups resonated as singlets at  $\tau$ 8.95, 8.99, 9.17 and 9.19 respectively.

Thus the above spectral data together with the molecular formula,  $C_{20}H_{32}O$ , were consistent with the di-terpene, I, possessing a tricyclic skeleton having one hydroxy, one vinyl and four methyl substituents together with an endocyclic double bond. Assuming the presence of geminal methyl groups at C-4 and a third methyl group at C-10, the problem of locating the other substituents remained to be solved. Because the methyl signals in the n.m.r. spectrum all occurred as singlets and from the pattern of splitting of the vinyl signals, it was obvious that the fourth methyl group and the vinyl group must both be attached to a fully substituted carbon atom. This evidence strongly indicated a pimarane type skeleton, and therefore the remaining methyl and vinyl groups must be situated at C-13. Furthermore, in order to satisfy the n.m.r. requirements, the nuclear double bond can only be located between C-8 and C-14. It was also obvious that the hydroxy group could not be attached to any of these substituents, and must therefore be located on one of the



nuclear carbon atoms. Since hydroxylation on rings B and C is rarely encountered in Euphorbiaceae diterpenes it was probable that the hydroxy group was on ring A, the most likely position being C-3.

Further Evidence of The Nature and Location of the Hydroxy Group in I

In order to confirm the secondary nature of the hydroxy group the alcohols I, LXXVIII (a) and LXXIX were oxidised with Jones' reagent (97) to the colourless ketones LXXXI, LXXXII and LXXXIII respectively. The ketone, LXXXI, whose molecular formula was established as  $C_{20}H_{30}O$  was characterised by the formation of a 2,4-dinitrophenylhydrazone. This evidence therefore confirmed that I was a secondary alcohol.

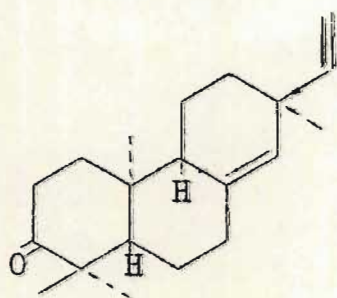

LXXXI

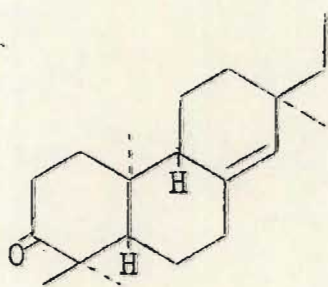

LXXXII

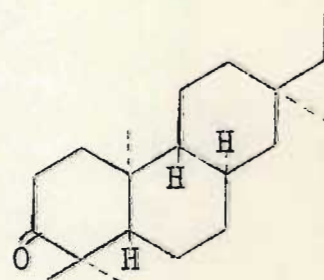

LXXXIII

The infrared spectrum of the ketone, LXXXI, (Figure 6) exhibited no hydroxy absorptions, but the expected carbonyl band occurred at  $1697\text{ cm}^{-1}$ . This

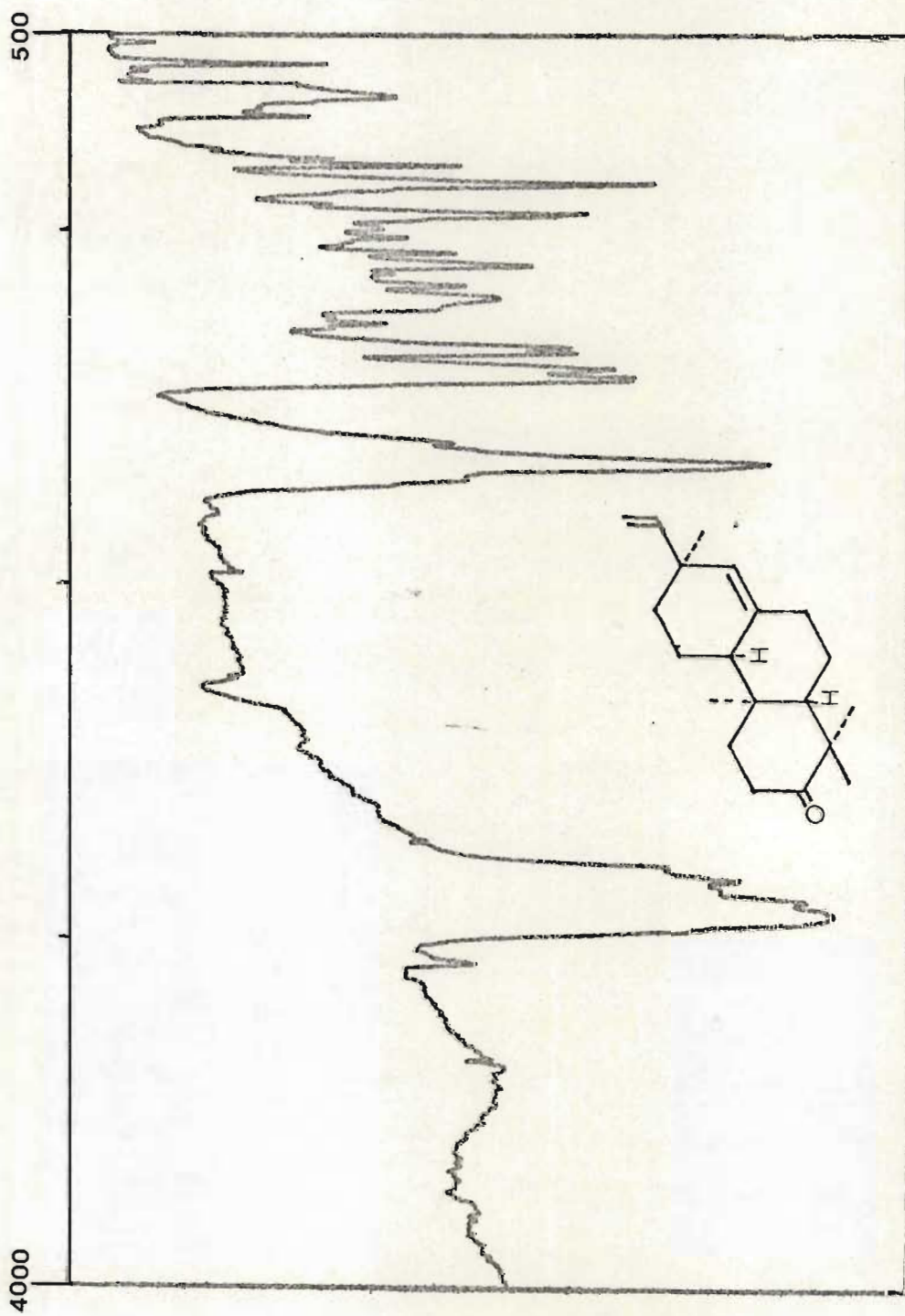

FIGURE 6 IR SPECTRUM OF *ent*-ISOPIMARA-8(14),15-DIEN-3-ONE

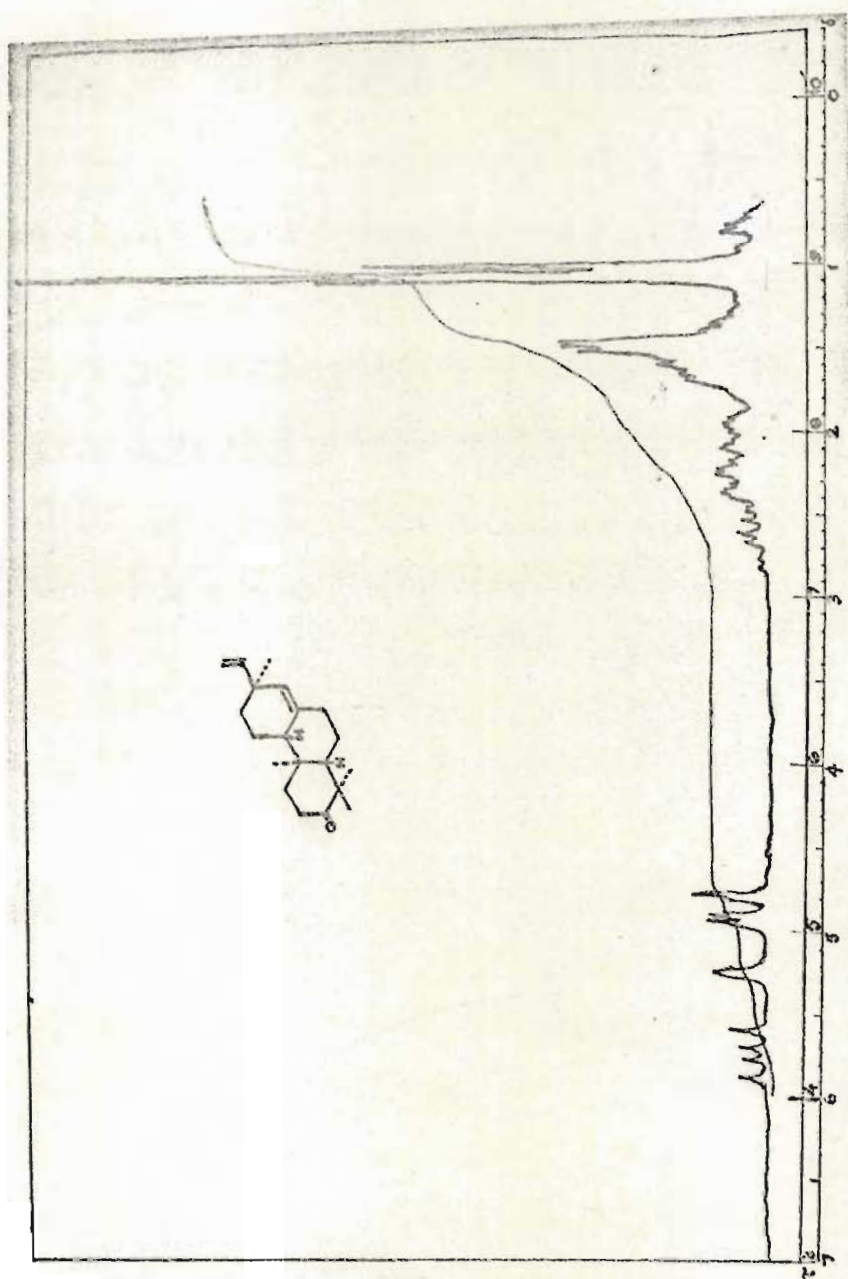

FIGURE 7 NMR SPECTRUM OF *ent*-ISOPIMARA-8(14), 15-DIEN-3-ONE



value is lower than that measured for a solution spectrum due to association in the solid state. The absorptions at 3078 and 1630  $\text{cm}^{-1}$  associated with the double bonds remained unchanged.

In the n.m.r. spectrum of the ketone, LXXXI, (Figure 7) the only major change observed was the disappearance of the signal due to the proton adjacent to the hydroxy group.

Finally, a very strong indication that the oxygen function was located at C-3 was provided by the positive reaction of the ketone, LXXXI, to the Zimmermann test which is characteristic for C-3 ketones (98). Thus it was concluded that I must be a C-3 diterpene alcohol.

#### The Basic Skeleton of I

The carbonyl group of the 3-ketone, LXXXI, was reduced by means of a Huang-Minlon reduction (99) via the intermediate hydrazone to produce the basic hydrocarbon,  $\text{C}_{20}\text{H}_{32}$ , LXXXIV. The infrared spectrum of this compound was typical of a hydrocarbon and exhibited the expected olefinic absorptions at 3080 and 1631  $\text{cm}^{-1}$ .

A survey of the literature revealed that the physical constants of this hydrocarbon were very similar to those reported for isopimara-8(14),15-diene, LXXXV (a), which had been isolated from pinkado wood derived from a tree, Xylia dolabriformis (Leguminosae) (100). An

authentic sample of the hydrocarbon was obtained for purposes of comparison. It was discovered that the infrared and mass spectra of LXXXIV and LXXXV (a) were superimposable, melting points and  $R_f$  values were almost identical, but a mixed melting point of the two compounds was depressed and their specific rotations, although similar in magnitude were opposite in sign.

Furthermore, two other constituents from Xylia dolabriformis were characterised as isopimara-8(14),15-dien-3-one, LXXXV (b) and isopimara-8(14),15-dien-3 $\beta$ -ol, LXXXV (c) and their reported physical constants were remarkably similar to those of the 3-ketone, LXXXI and the alcohol, I, respectively. Again the infrared and mass spectra of the corresponding pairs were found to be superimposable while their mixed melting points were depressed and their specific rotations of opposite sign.

This evidence led to the conclusion that the hydrocarbons, LXXXIV and LXXXV (a), the ketones, LXXXI and LXXXV (b), and the alcohols, I and LXXXV (c) were in fact enantiomeric pairs. Proof of this relationship was established by means of optical rotatory dispersion. Curves were obtained (Figure 8) for the two ketones, LXXXI and LXXXV (b) under identical conditions. It was obvious that the former displayed a positive Cotton effect and the latter a negative Cotton effect (101). In agreement with the findings of Enzell et al (102) on the 8(14),15-pimaradienes both ketones exhibited the usual o.r.d. curves. Most significant



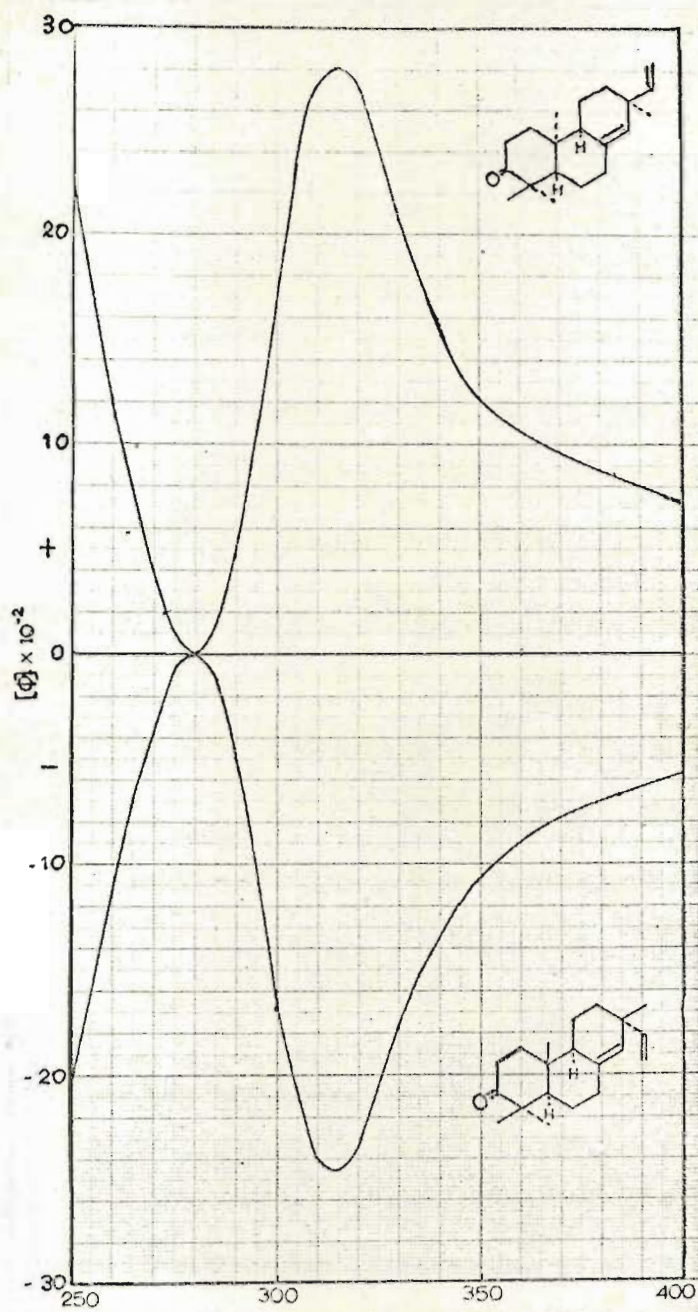

FIGURE 8 ORD CURVES OF ent-ISOPIMARA-8(14),15-DIEN-3-ONE

AND ISOPIMARA-8(14),15-DIEN-3-ONE



of all was the fact that the curves were antipodal since the peaks and troughs coincided at the same wavelengths, the values being  $[\phi]_{315} + 2810^\circ$ ,  $[\phi]_{280} 0^\circ$  for LXXXI and  $[\phi]_{315} - 2460^\circ$  and  $[\phi]_{280} 0^\circ$  for LXXXV (b). Thus the ketones, LXXXI and LXXXV (b) are clearly enantiomeric with the former possessing the  $5\beta$ -hydrogen,  $10\alpha$ -methyl,  $9\beta$ -hydrogen and  $13\beta$ -vinyl substituents. These results are consistent with those reported by Enzell et al (102) who found that the o.r.d. curve exhibited a positive maximum in the case of a pimaradiene with the C-13 vinyl group in the  $\beta$ -configuration and a negative maximum when the vinyl group was in the  $\alpha$ -configuration.

From the foregoing evidence it therefore follows that the alcohol, I, and the hydrocarbon LXXXIV are enantiomers of LXXXV (c) and LXXXV (a) respectively. The fact that I, possesses the  $5\beta$ -hydrogen,  $10\alpha$ -methyl A/B trans-fused ring system is consistent with the stereochemistry of all the diterpenes previously isolated from the Euphorbiaceae. As would be expected for such a normal trans-anti-fused backbone the C-9 hydrogen is in the  $\beta$ -configuration, but the accompanying C-13 $\beta$ -vinyl group is a feature which has not previously been encountered. Thus the alcohol, I, is the first recorded natural occurrence of a compound possessing the ent-isopimaradiene skeleton.

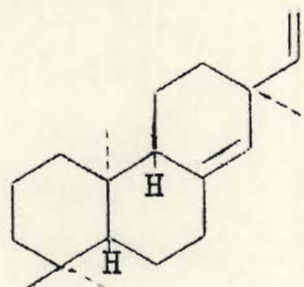

LXXXIV

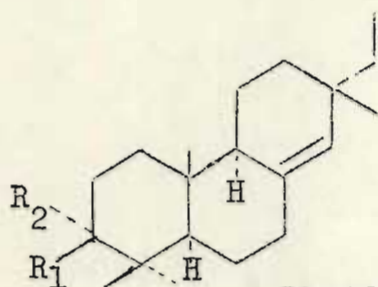

LXXXV

	R <sub>1</sub>	R <sub>2</sub>
(a)	H	H
(b)		O
(c)	OH	H
(d)	OAc	H

The physical constants and molecular formulae of the three enantiomeric pairs are tabulated in Table 1 which serves to emphasise the similarity of data between each pair except for the specific rotations which indicate an antipodal relationship. Constants for the acetate, LXXXV (d), and the hydrogenated alcohols, LXXXVI and LXXXVII, are also provided for comparison with those of the corresponding derivatives of the alcohol, I.

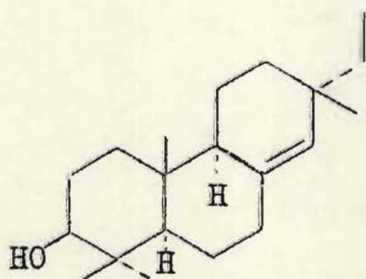

LXXXVI

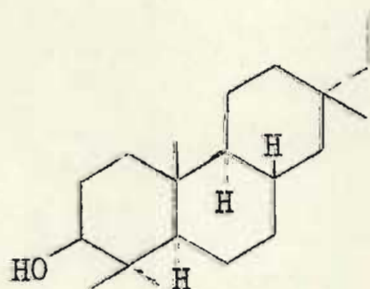

LXXXVII

TABLE 1

Compound	Formula	Mol. wt.	m.p.	$[\alpha]_D$
I	$C_{20}H_{32}O$	288	126-127°	+12.5°
LXXXV (c)	$C_{20}H_{32}O$	288	126.5-127.5°	-19.5°
LXXVII	$C_{22}H_{34}O_2$	330	104-105°	-7°
LXXXV (d)	$C_{22}H_{34}O_2$	330	102-104.5°	+4°
LXXVIII (a)	$C_{20}H_{34}O$	290	132-133°	-23.2°
LXXXVI	$C_{20}H_{34}O$	290	132-132.5°	+25.5°
LXXIX	$C_{20}H_{36}O$	292	135°	-46.8°
LXXXVII	$C_{20}H_{36}O$	292	134-135.5°	+21.8°
LXXXI	$C_{20}H_{30}O$	286	60°	+45°
LXXXV (b)	$C_{20}H_{30}O$	286	59-60°	-56°
LXXXIV	$C_{20}H_{32}$	272	38-39°	+7°
LXXXV (a)	$C_{20}H_{32}$	272	38-39.5°	-12.4°



### Bromination Experiments

During the study of spirostachic acid, VIII, (to be discussed in Part 2) it was found that the mass spectra of 2,3-seco-dioic acids displayed characteristic fragments due to the loss of the C-1 — C-2 and C-3 — C-4 groupings. The application of these results had proved invaluable in the elucidation of the structure of cleistanthol, IV, (1,2, 3). With this view in mind, an attempt was made to convert the tetrahydroketone, LXXXIII, to the corresponding 2,3-seco-dioic acid.

The intended scheme was to obtain the seco-acid via the  $\alpha$ -bromoketone, LXXXVIII, followed by hydrolysis and a Lemieux-von Rudloff oxidation. The latter two steps failed to produce the desired product but the intermediate bromination products proved to be interesting. Treatment of a benzene solution of the tetrahydroketone, LXXXIII, with bromine resulted in an initial slow uptake of bromine followed by a further more rapid uptake, which furnished a compound having the formula,  $C_{20}H_{32}OBr_2$ .

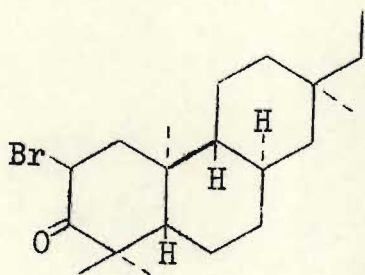

LXXXVIII

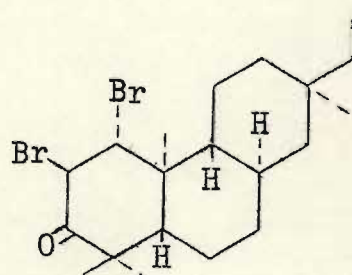

LXXXIX

The n.m.r. spectrum of the 1,2-dibromoketone, LXXXIX, exhibited an AB system comprising two doublets at  $\tau$ 6.25 and 6.92 ( $J_{AB}=16$  Hz.). From the large coupling constant observed for the C-1 and C-2 protons it was evident that they were trans-diaxially orientated (104), and hence the bromine atoms must have been trans-diequatorially orientated.

The formation of the 1,2-dibromoketone, LXXXIX, was probably initiated by the relatively slow process of  $\alpha$ -bromination of the tetrahydroketone, LXXXVIII, giving rise to the  $\alpha$ -bromoketone, LXXXVIII(a), during which the elements of hydrogen bromide were eliminated to give the  $\alpha,\beta$ -unsaturated ketone, XC. Further bromination of the C-1, C-2 double bond would then produce the observed 1,2-dibromoketone, LXXXIX, as outlined below.

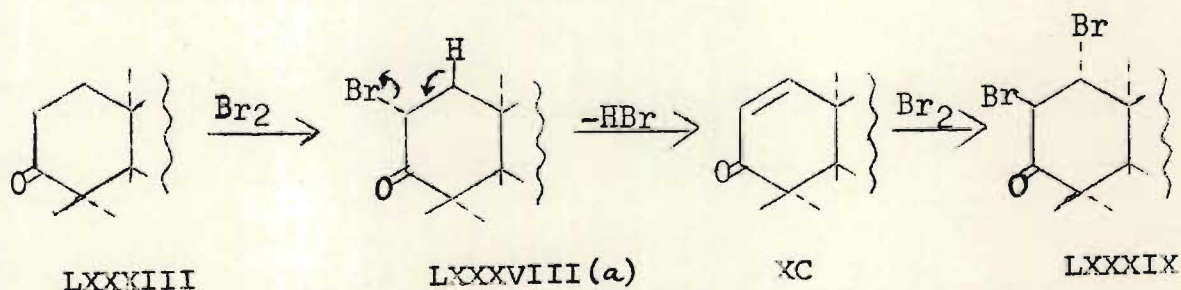

In order to inhibit the elimination of hydrogen bromide in the sequence shown above, the bromination was repeated in acetic acid medium in the presence of hydrobromic acid (76). This afforded both the mono- and the di-bromo- compounds which were separated by means of preparative thin layer chromatography. The  $\alpha$ -bromoketone, LXXXVIII, was shown by accurate mass measurements to possess the



molecular formula,  $C_{20}H_{33}OBr$ , whilst its n.m.r. spectrum indicated that the bromine was equatorially orientated due to the relatively low field signal of the C-2 hydrogen at  $\tau 4.99$  (105,106). This is not unexpected since in the case of the analogous keto-steroids the equatorial bromide is the thermodynamically more stable isomer, although the axial bromide may be formed initially (107). Furthermore, for a 2-bromo-4,4-dimethylcyclohexanone the preferred conformation is the chair-form in which the bromine is equatorial (108). A comparison of the infrared spectra of the tetrahydroketone, LXXXIII, and the  $\alpha$ -bromoketone, LXXXVIII, showed an increase in frequency of the C=O stretching vibration from  $1695\text{ cm}^{-1}$  to  $1720\text{ cm}^{-1}$  which confirmed the equatorial orientation of the C-2 bromine (109).

### Mass Spectra

The mass spectra of some pimarane diterpenes have been briefly studied by Audier et al (103) who found that in general, the major peaks in the spectra could be explained by fragmentations analogous to those reported for the bicyclic diterpenes (110). However, all Audier's work was performed on the unsaturated pimaradiene skeletons and in no instance were the spectra of the hydrogenated compounds analysed.

The mass spectrum of the alcohol, I, (Figure 9) exhibited a molecular ion peak at  $m/e$  288 which was in



agreement with the molecular formula  $C_{20}H_{32}O$  determined by elementary analysis. It was noted that the fragmentation pattern was very similar to that of a published spectrum of isopimara-8(14),15-dien-3 $\beta$ -ol, LXXXV (c). Comparison of the mass spectrum of I with that of an authentic sample of LXXXV (c) isolated from Xylia dolabriformis (100) revealed that the pattern of fragmentation was the same in the two cases, but there were variations in peak intensities.

The spectra of I and its derivatives showed distinctly related fragmentation patterns and an attempt will be made to propose structures for the various ions which would provide added support to the evidence already presented for their structures. Unfortunately, the ion fragments have not been confirmed by labelling experiments or accurate mass determinations, but the proposals are based on reasonable and most probable cleavage mechanisms.

A notable feature in the spectrum of I was the intensity ratio of the M-18 ion (14%) to the molecular ion,  $M^+$  (36%), which resulted in a value less than unity. By analogy with the observations made during a study of the mass spectra of a series of monohydroxy steroids (111) this was added proof that the hydroxy group was in the equatorial configuration, since such alcohols dehydrate less readily under electron impact than their axial epimers.

The major peaks in the upper half of the spectrum of I were due to the molecular ion,  $M^+$ , and ions at M-15, M-18, M-27 and M-33. The M-15 fragment was almost certain-

ly due to the loss of the C-13 methyl group as this fragmentation involves the cleavage of a bond which is allylic to two olefinic double bonds. The M-18 ion which was of similar intensity to the M-15 ion, could be explained by the loss of water from the molecular ion, while the M-33 fragment probably arose by the loss of water from the M-15 ion.

Both of these cleavages were strongly supported by the appearance of metastable ions at  $m/e$  253 ( $288 \rightarrow 270$ ) and at  $m/e$  238 ( $273 \rightarrow 255$ ) respectively. It was also possible that the M-33 ion could have been derived through the loss of a methyl group from the M-18 ion since this was suggested by the presence of a very weak metastable ion at  $m/e$  241 ( $270 \rightarrow 255$ ) (Scheme 1).

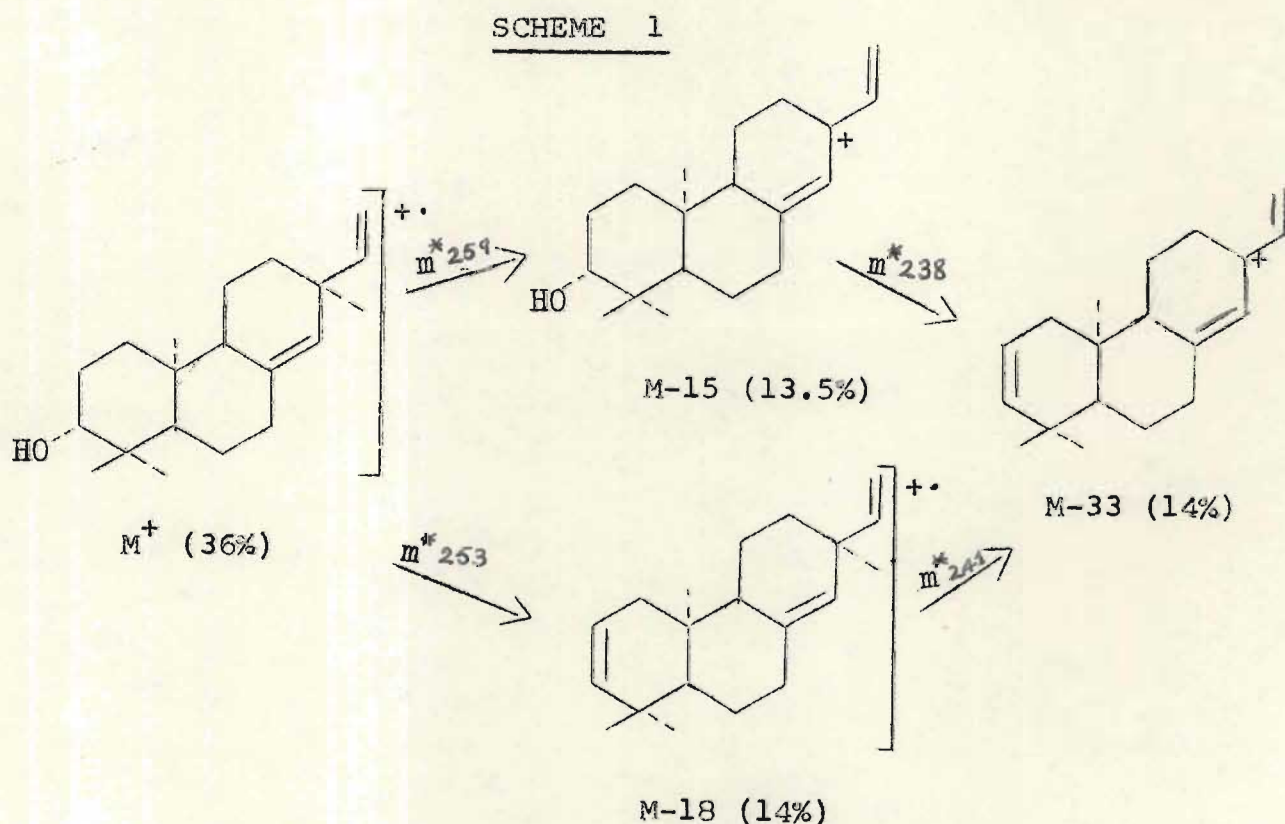



The M-27 ion was of lower intensity than the ions mentioned above and was probably due to the loss of the C-13 vinyl group. The low abundance of this ion is explained by the fact that its formation involves the cleavage of a vinyl bond albeit allylic to the 8(14)-double bond as shown below.

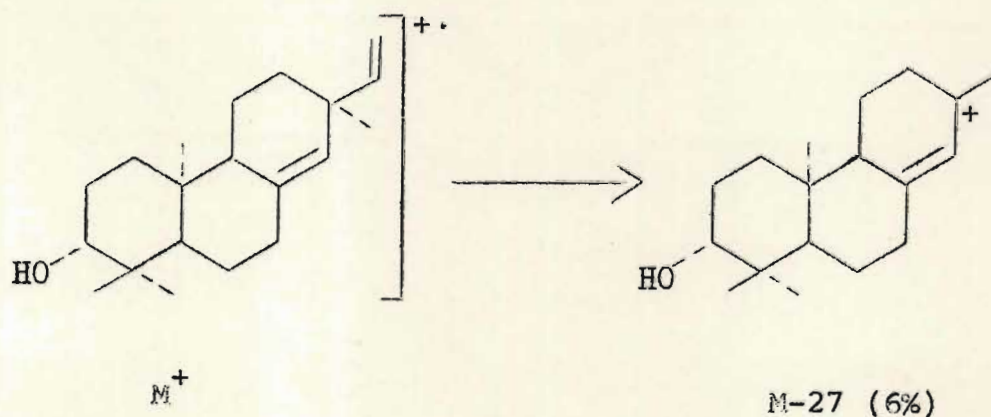

Acetylation of the hydroxyl group made very little difference to the spectrum (Figure 10) in which the molecular ion appeared at  $m/e$  330. The M-18 and M-33 fragments were replaced by M-60 and M-75 ions due to the loss of the elements of acetic acid (by a McLafferty rearrangement) from the molecular ion and the C-13 methyl group from the M-60 ion respectively. The peaks in the lower half of the spectrum were almost completely unchanged by acetylation.

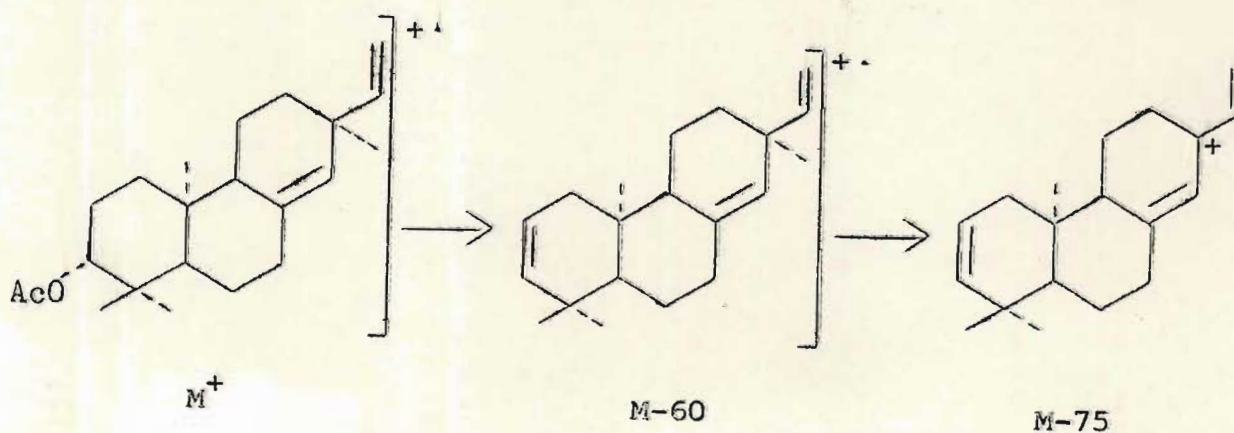



Hydrogenation of the vinyl double bond gave rise to a spectrum (Figure 11) in which the main differences were the appearance of the molecular ion at  $m/e$  290 and of fairly intense peaks at  $m/e$  261 and 243. The M-29 fragment probably arose from the loss of the C-13 ethyl group and corresponds with the M-27 ion discussed for the parent alcohol, I. The marked increase in intensity of this ion could be explained by the fact that its formation no longer involved the cleavage of a vinyl bond and was thus a more favoured process than that for the formation of the M-27 ion. This cleavage mechanism was supported by the appearance of a weak metastable peak at  $m/e$  235. The M-47 fragment could be readily explained by assuming the loss of the elements of water from the molecular ion to give the M-18 fragment at  $m/e$  272 ( $m^* 255.2, 290 \rightarrow 272$ ) followed by the loss of the C-13 ethyl moiety ( $m^* 217, 272 \rightarrow 243$ ). A small contribution to the M-47 ion could also have arisen from the reverse pattern of fragmentation i.e. loss of water from the M-29 ion.

In addition to being allylic to the 8,14-double bond the bulkier nature of the C-13 ethyl group obviously facilitated the cleavage of this substituent rather than the C-13 methyl group. This therefore accounts for the lower intensity of the M-15 peak in Figure 11. The M-33 ion was shown by the presence of a metastable ion at  $m/e$  243 to result from the loss of the C-13 methyl group from the M-18 ion, and again the intensity of this peak was much

lower than that of the peak due to the M-47 ion (Scheme 2).

SCHEME 2

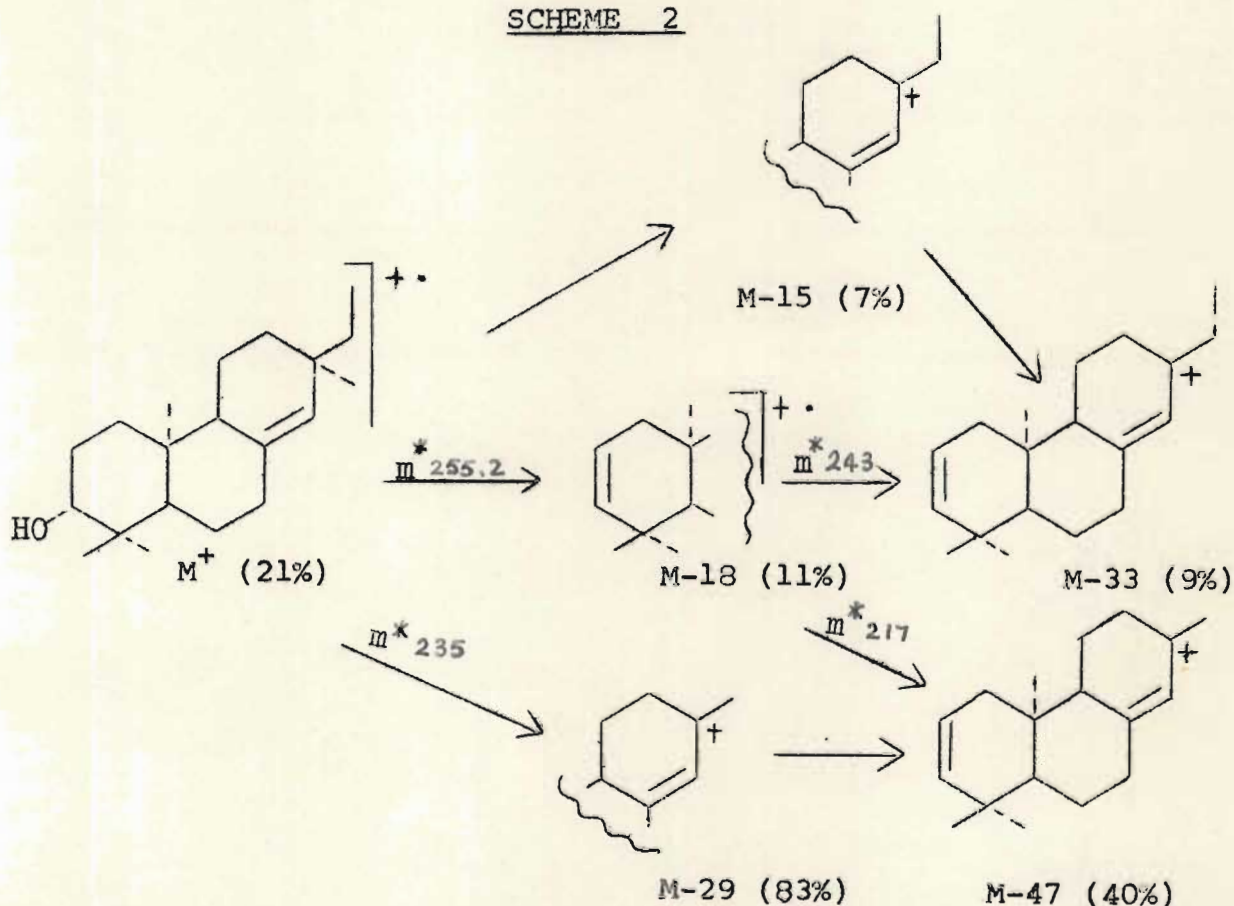

In the spectrum of the tetrahydro alcohol, LXXIX, (Figure 12) the significant features were the appearance of the molecular ion at  $m/e$  292, increased intensities of the M-18 peak and peaks at  $m/e$  191 and 163. Since the double bonds have been fully reduced there is less incentive for the cleavage of the C-13 substituents and hence a low abundance of the M-15 (7%) and M-29 (9%) fragments. The loss of water from the molecular ion is by comparison now a more favoured process resulting in the M-18 ion (32%) at  $m/e$  274, and confirmed by a metastable ion at  $m/e$  257. This ion then loses either the C-13 methyl group to yield the



M-33 ion (22%) at  $m/e$  259 or the preferred bulkier ethyl group to give the M-47 ion (41%) at  $m/e$  245. The fragmentation pattern giving rise to the M-101 and M-129 ions was probably initiated by a retro Diels-Alder rearrangement of the M-18 ion (Scheme 3).

SCHEME 3

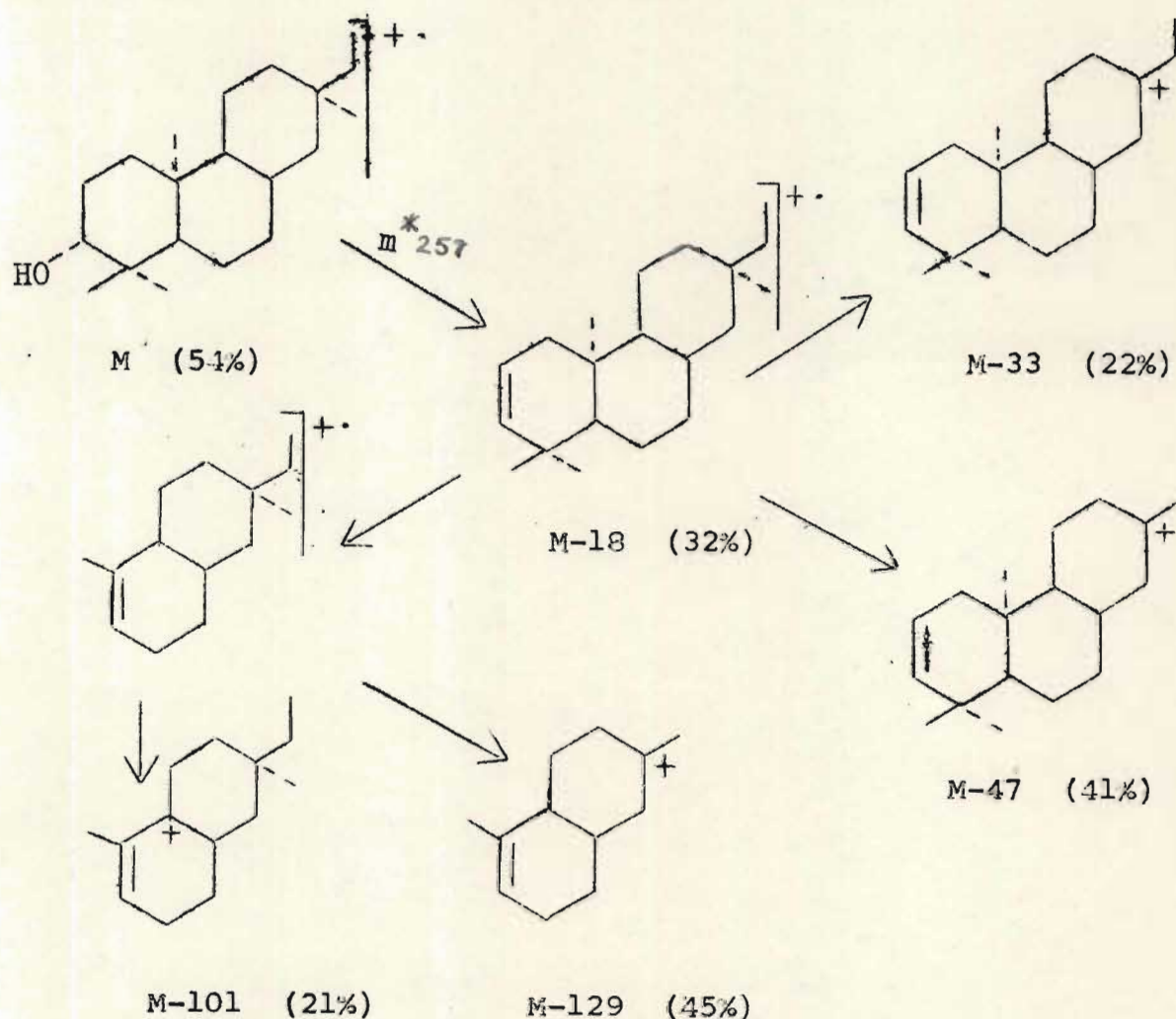

The base peak in the spectrum of the parent alcohol, I, (Figure 9) occurred at  $m/e$  135 (M-153). This fragment was unchanged by acetylation or hydrogenation of



the vinyl double bond, thereby implying that this ion contained neither the oxygen function nor the vinyl group. Confirmation of this fact was obtained by an accurate mass measurement of this peak which established the formula of the ion to be  $C_{10}H_{15}$ . The formation of this ion could be explained by a process proposed by Enzell *et al* (110) for the formation of the corresponding ion in the spectra of bicyclic diterpenes possessing a C-8, C-20 double bond. It was also possible for this ion to lose one of its C-4 substituents together with a hydrogen atom to give the M-169 ion at  $m/e$  119 as shown below. Enzell determined that the process was favoured by increasing molecular weight of the C-4 substituents, and when these were either  $-COOH$  or  $-COOCH_3$ , the latter ion frequently formed the base peak in the spectrum.

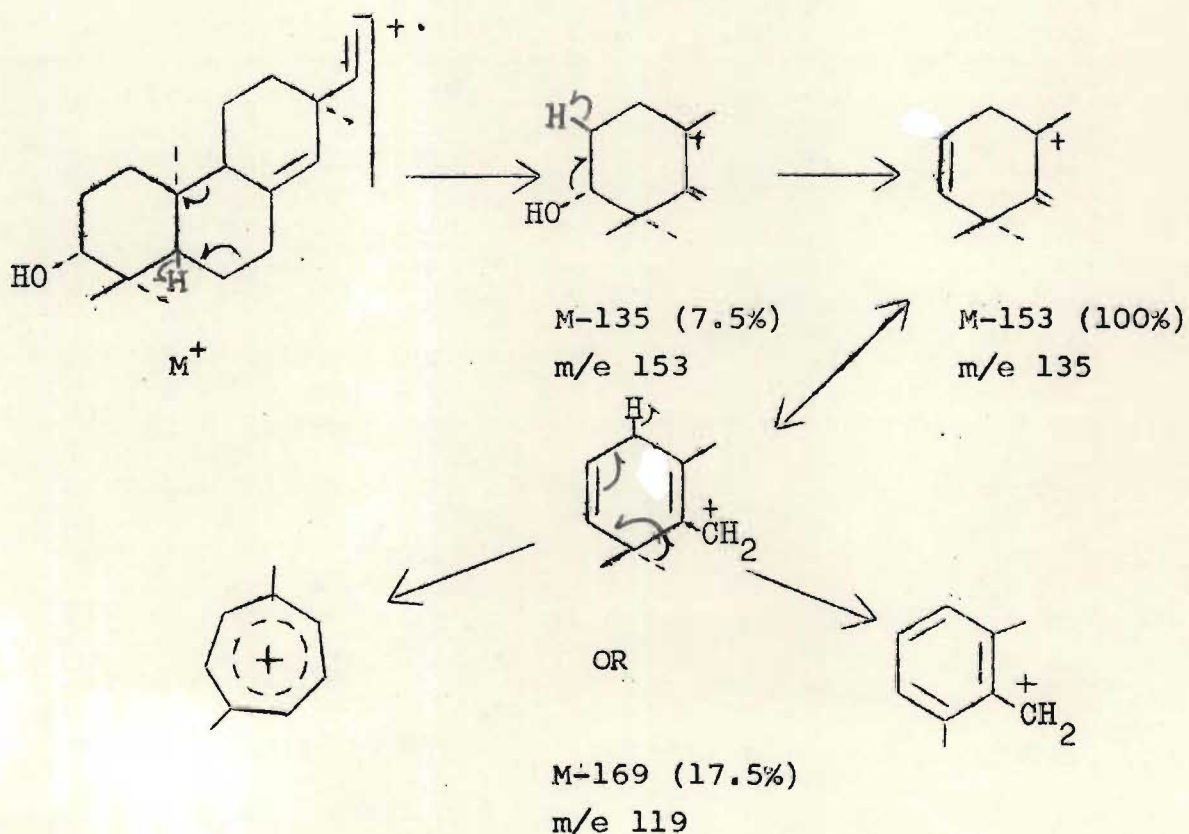

The relatively abundant ions at  $m/e$  152 and  $m/e$  134 could have arisen by a process outlined by Audier *et al* (103) for the formation of a fragment similar to the former ion in the spectrum of the hydrocarbon, LXXXV (a). Loss of water from this ion probably gave rise to the  $m/e$  134 fragment, while cleavage of a methyl group from the latter would provide an alternative pathway to the M-169 ion.

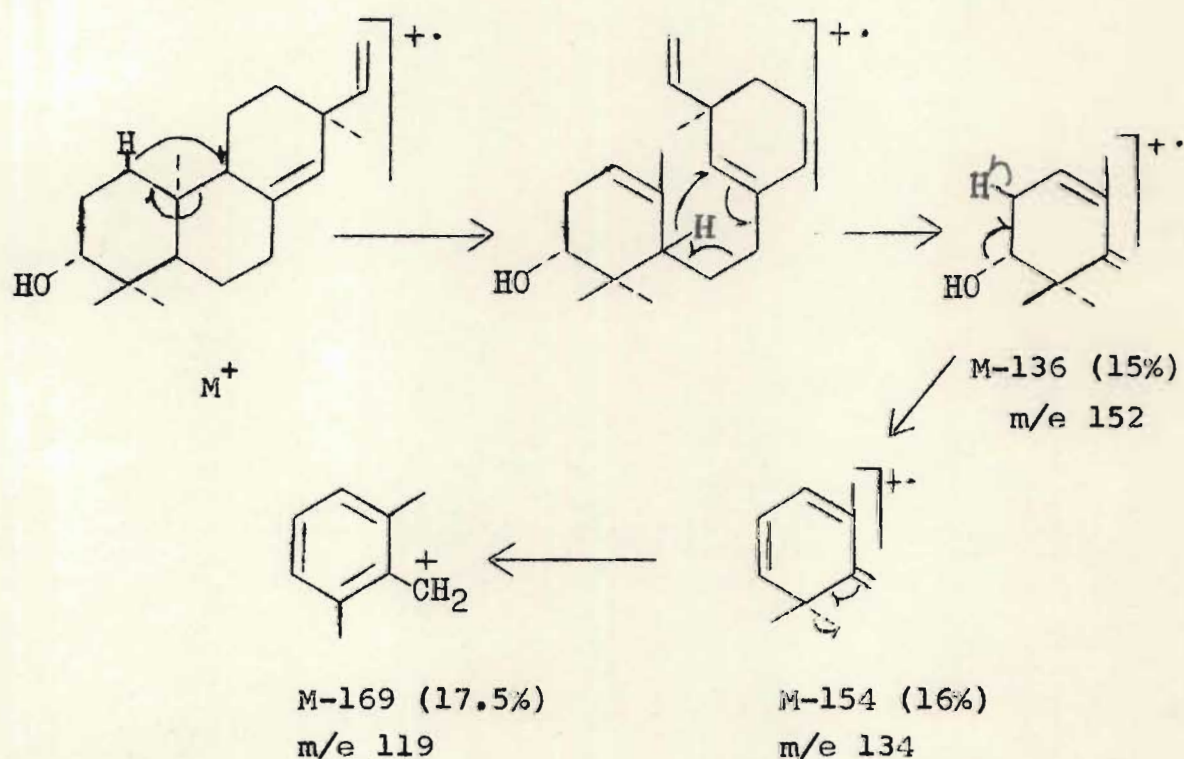

In the lower half of the spectrum the only significant peaks which underwent any change on hydrogenation of the vinyl double bond were those at  $m/e$  148 in the spectra of I (Figure 9) and its acetate (Figure 10) which appeared at  $m/e$  150 in the spectra of their dihydro derivatives. This fragment probably arose by the process outlined below involving the same intermediate proposed for the formation



of the M-136 ion at m/e 152.

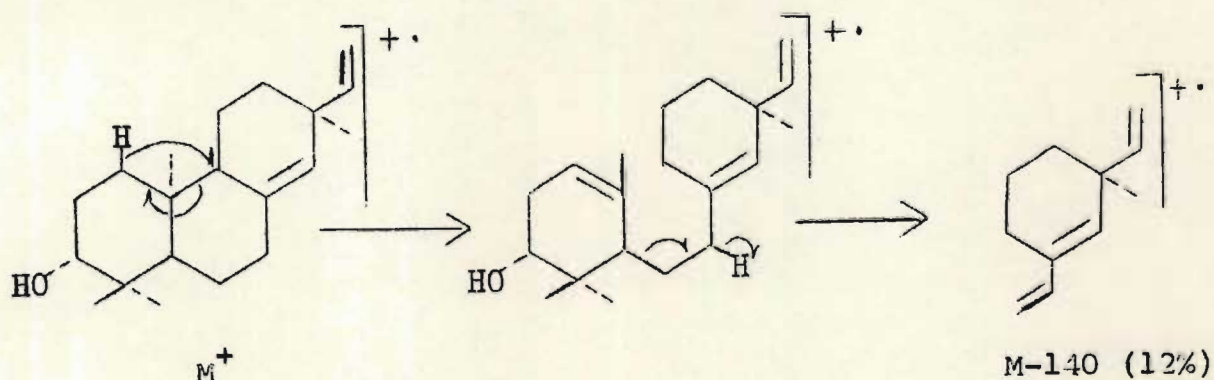

The peaks at m/e 136 and m/e 121 might have arisen from the molecular ion or the M-18 ion by the process outlined below, which is essentially very similar to those proposed for the formation of the m/e 152, 134, and 148 fragments but involves a transfer of a hydrogen atom from C-11 to C-10 rather than from C-1 to C-9 as in the above cases. It was considered most likely that the m/e 136 fragment was derived from the M-18 ion for if it had arisen from the fragmentation of the molecular ion a significant peak would have been expected at m/e 154, followed by the loss of the elements of water to produce the m/e 136 fragment. Loss of one of the C-4 methyl groups from the ion at m/e 136 provided an explanation for the fragment appearing at m/e 121.

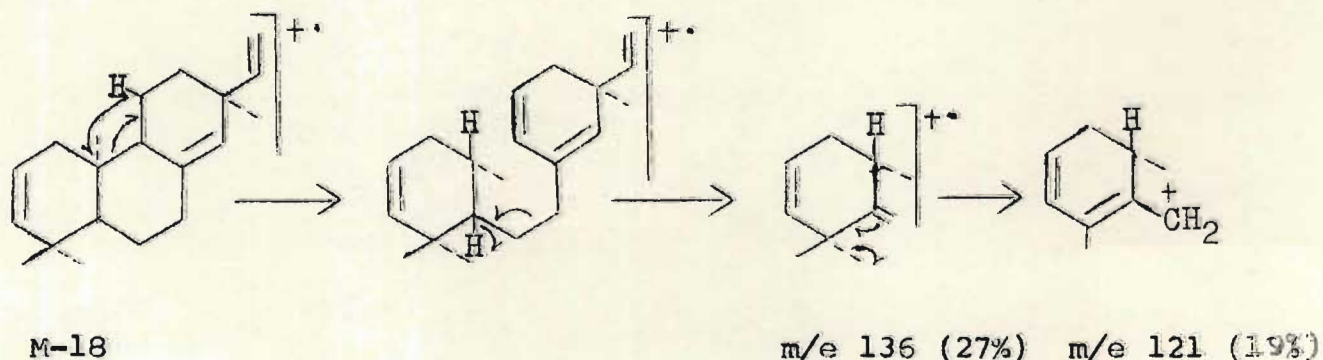



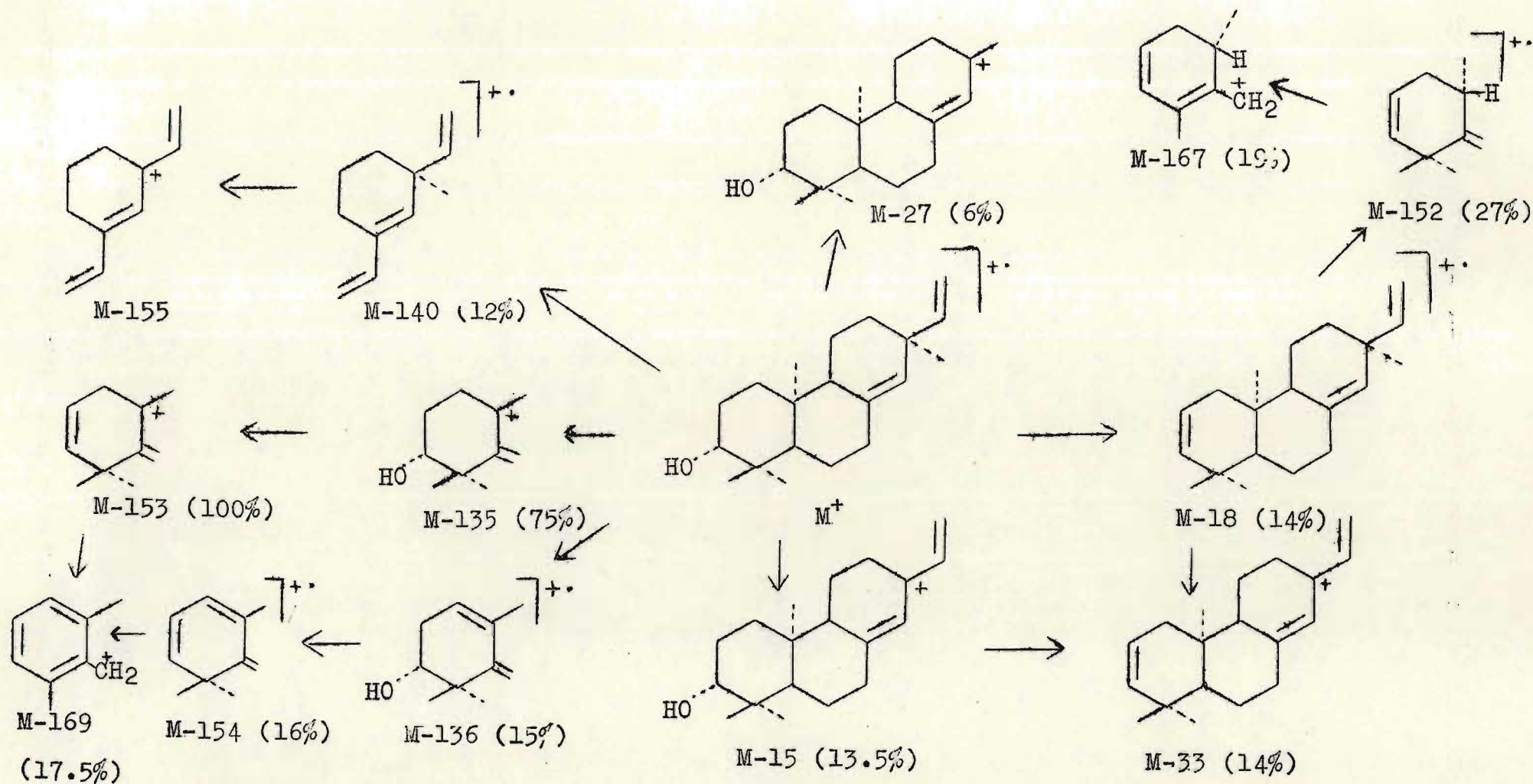

SCHEME 4

In the spectra of the 3-ketone, LXXXI, (Figure 13) and its dihydro- and tetrahydro- derivatives (Figures 14 and 15) the appearance of the molecular ions at  $m/e$  286, 288 and 290 were all in agreement with the formulae  $C_{20}H_{30}O$ ,  $C_{20}H_{32}O$  and  $C_{20}H_{34}O$  respectively.

Peaks in the upper half of each spectrum corresponded well with the fragmentations proposed for similar ions in the spectra of the C-3 alcohols. However, ions appearing in the lower halves of the spectra showed little correlation and were thus difficult to analyse. The fragment at  $m/e$  135 no longer formed the base peak in these spectra as had been the case for the alcohols. Audier *et al* (103) outlined the process below for the formation of this ion in C-3 ketones, but this representation of the ion is open to question since it was observed that upon hydrogenation of the vinyl bond (Figure 14) the intensity of the  $m/e$  135 fragment was still greater than that of the  $m/e$  137 fragment.

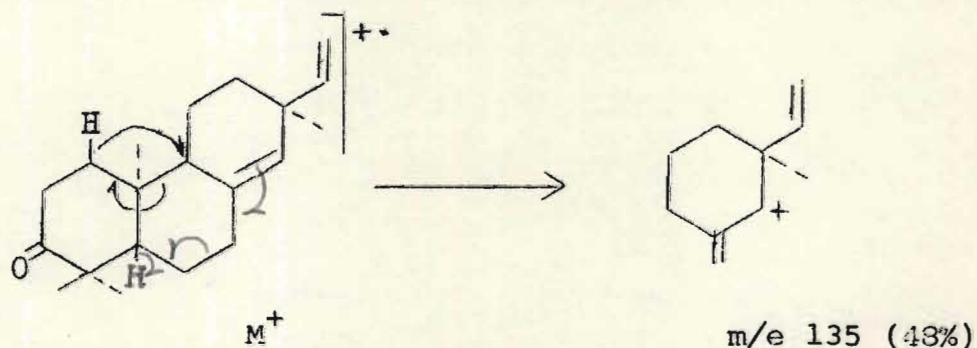

Comparison of the spectrum of *ent*-isopimara-8(14), 15-diene, LXXXIV, (Figure 16) with those of an authentic sample of its enantiomer and a published spectrum (103) revealed that the fragmentation patterns were identical.

The molecular ion formed the base peak in Figure 16, appearing at  $m/e$  272 in agreement with the formula  $C_{20}H_{32}$ . The fragments were similar to those proposed for the alcohol, I, except that no ions involved the loss of the elements of water due to the absence of the hydroxy group. Prominent peaks at  $m/e$  136 and 137 have been explained (103) and their mechanisms of cleavage are shown below.

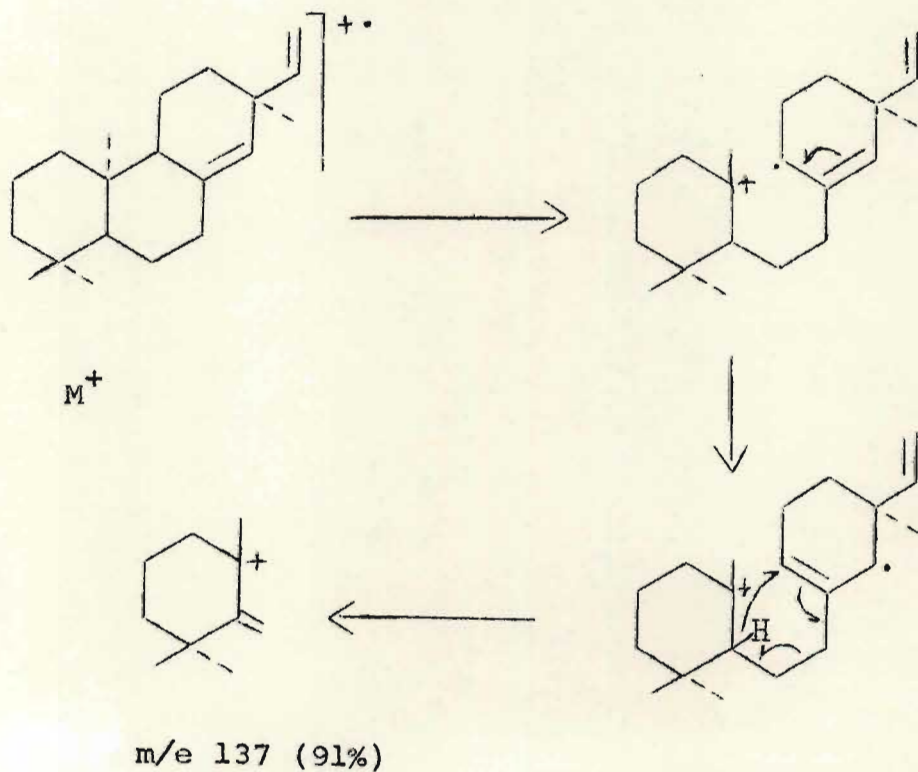
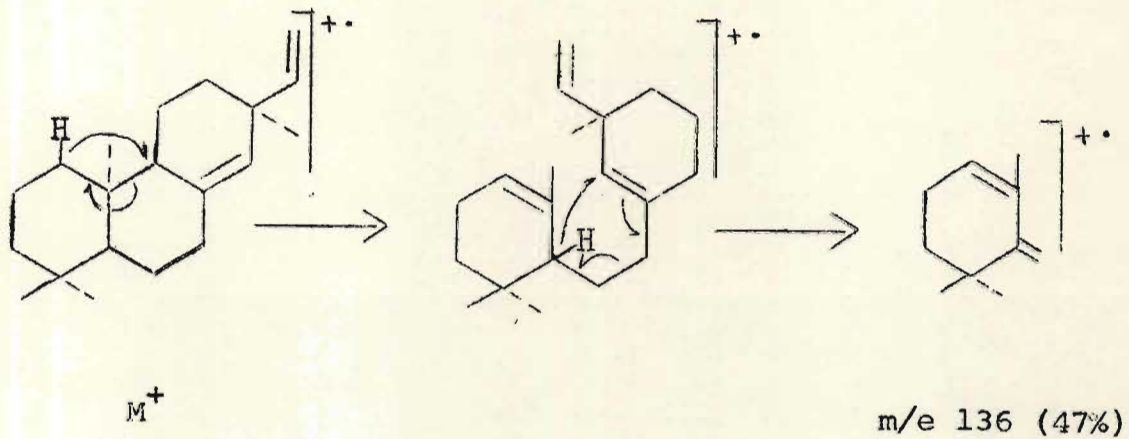



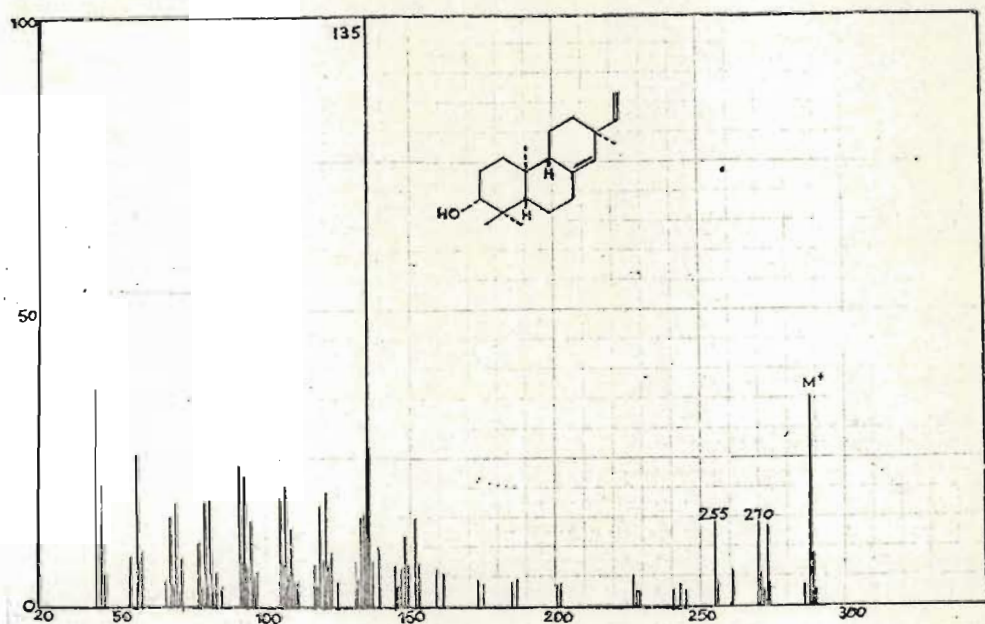

FIGURE 9 MASS SPECTRUM OF 3 $\alpha$ -HYDROXY-ent-ISO-PIMARA-8(14),15-DIENE

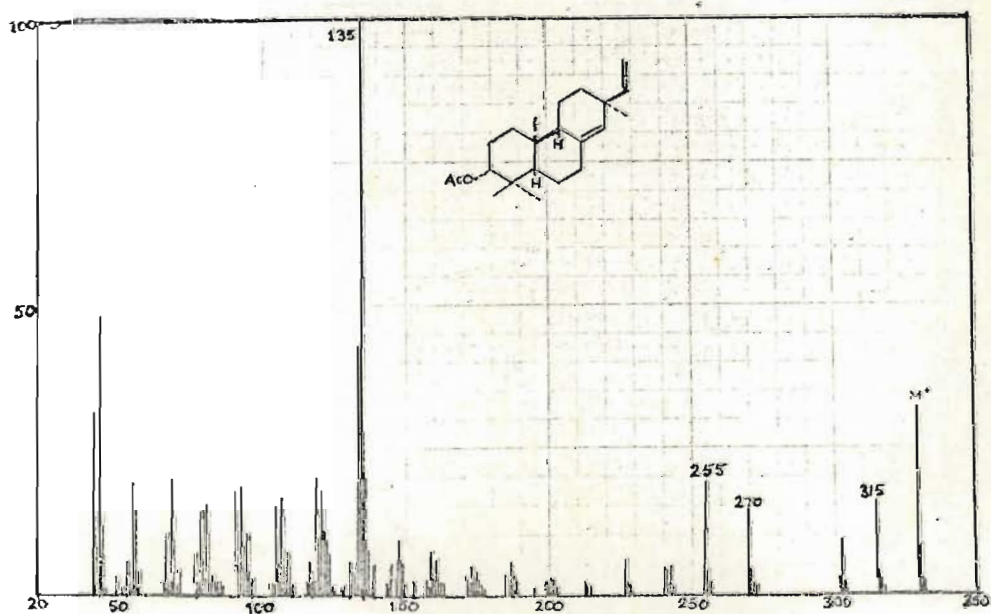

FIGURE 10 MASS SPECTRUM OF 3 $\alpha$ -ACETOXY-ent-ISO-PIMARA-8(14),15-DIENE

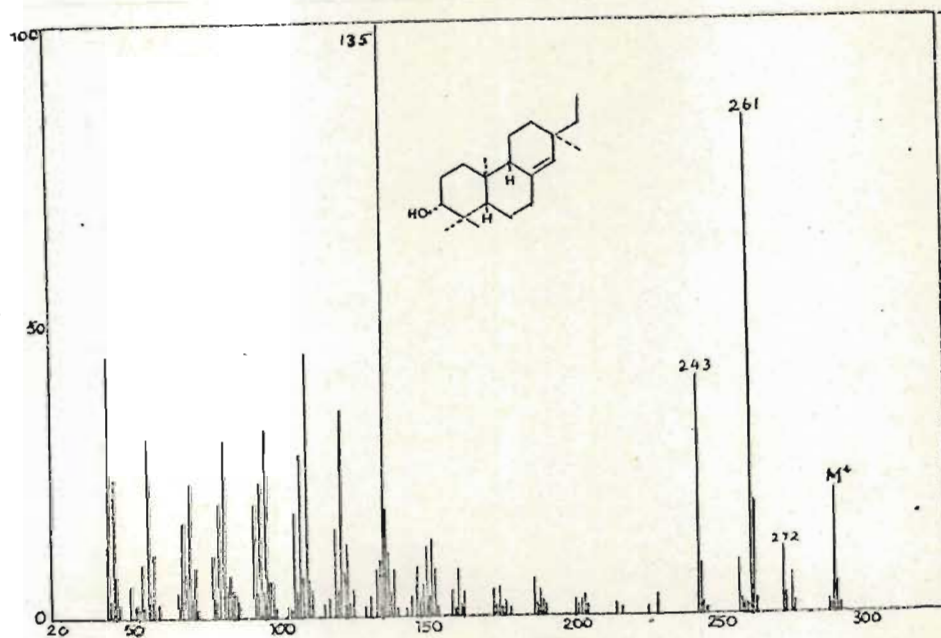

FIGURE 11 MASS SPECTRUM OF 3 $\alpha$ -HYDROXY-ent-ISOPIMAR-8(14)-ENE

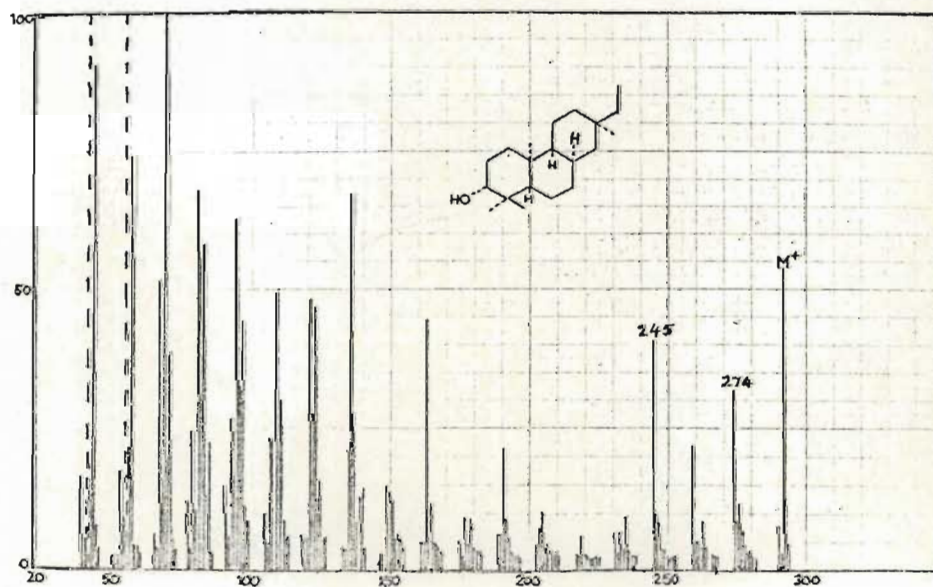

FIGURE 12 MASS SPECTRUM OF 3 $\alpha$ -HYDROXY-ent-ISOPIMARANE

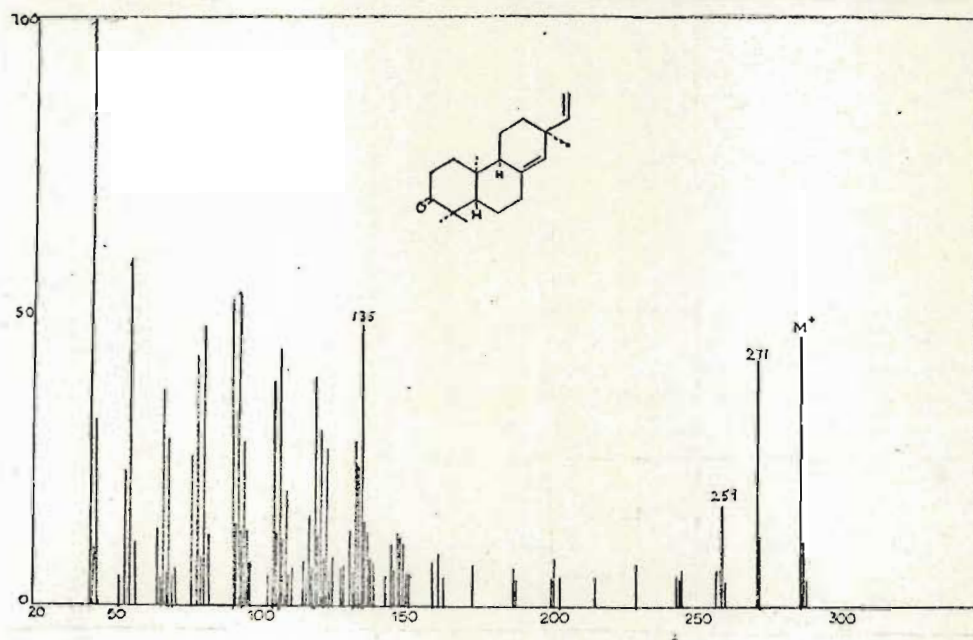

FIGURE 13 MASS SPECTRUM OF *ent*-ISOPIMARA-8(14),15-DIEN-3-ONE

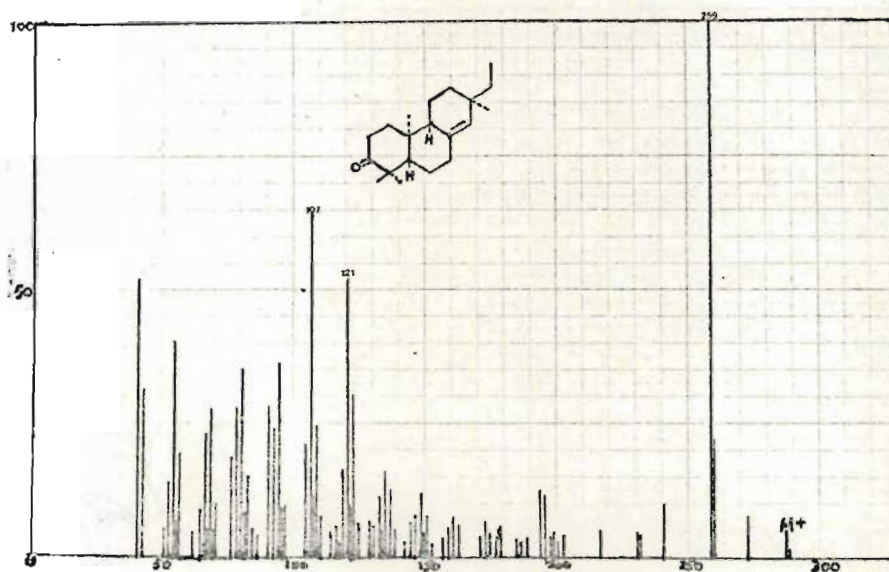

FIGURE 14 MASS SPECTRUM OF *ent*-ISOPIMAR-8(14)-EN-3-ONE



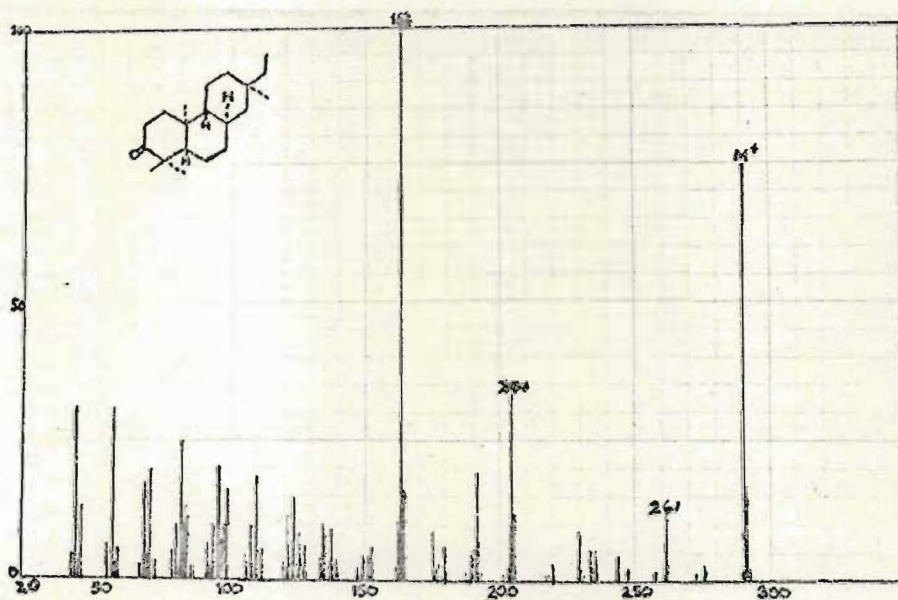

FIGURE 15 MASS SPECTRUM OF *ent*-ISOPIMARAN-3-ONE

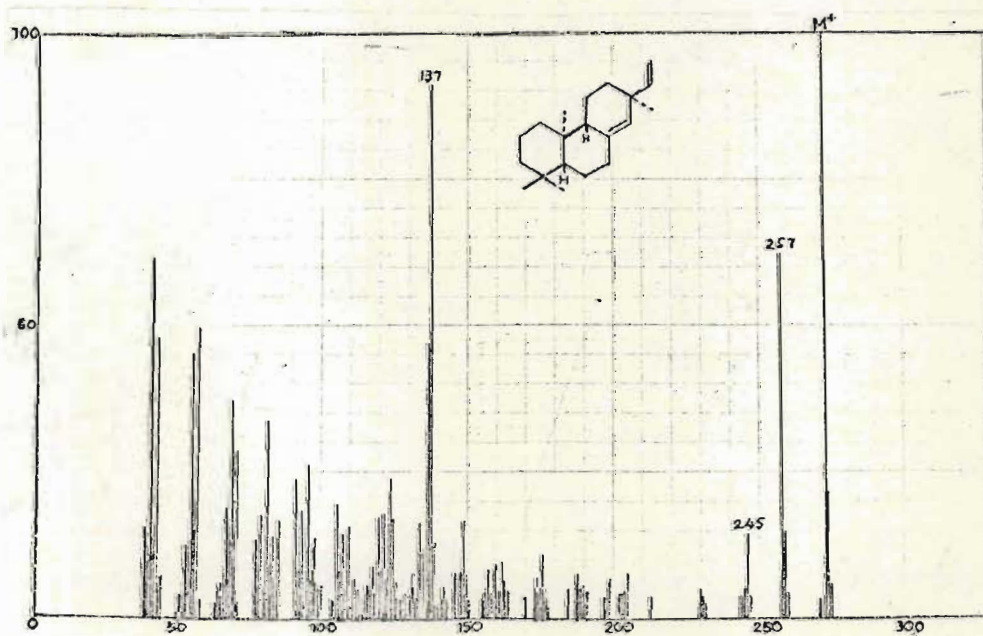

FIGURE 16 MASS SPECTRUM OF *ent*-ISOPIMARA-8(14),15-DIENE

1.2. 3 $\alpha$ -Hydroxy-ent-isopimara-8(14),15-dien-12-one, II.

The second crystalline component obtained in fair yield (0.2% of the heartwood) by means of column chromatography was 3 $\alpha$ -hydroxy-ent-isopimara-8(14),15-dien-12-one, II.

As in the case of the alcohol, I, this compound produced no colour with the Liebermann-Burchard reagent or on treatment with neutral methanolic ferric chloride, but a positive tetranitromethane test indicated the presence of unsaturated olefinic linkages.

The Oxygen Functions

In the infrared spectrum of this diterpene, C<sub>20</sub>H<sub>30</sub>O<sub>2</sub> (Figure 17) bands at 3547 and 1696 cm.<sup>-1</sup> implied that the molecule possessed both hydroxy and carbonyl substituents. The position of the carbonyl absorptions for six-membered ring ketones is usually in the region between 1705 - 1725 cm.<sup>-1</sup>, and thus the low frequency of this absorption in the spectrum of II was probably due to association in the solid state or the proximity of double bonds to the carbonyl function (112).

The formation of both a monoacetate, C<sub>22</sub>H<sub>32</sub>O<sub>3</sub>, XCI, and a mono-oxime, C<sub>20</sub>H<sub>31</sub>NO<sub>2</sub>, XCII, substantiated the presence of a single hydroxy and a single keto group in this compound. In the infrared spectrum of the ketol acetate the expected carbonyl absorption appeared at 1700 cm.<sup>-1</sup> together with the additional acetate carbonyl stretching vibration at 1723 cm.<sup>-1</sup> and the ester C-O stretching vibration at 1243 cm.<sup>-1</sup>, while bands due to the



hydroxy group disappeared. The infrared spectrum of the oxime exhibited the characteristic C=N stretching frequency at  $1645\text{ cm.}^{-1}$  as a moderately strong peak while the carbonyl band disappeared. A broad band centred around  $3300\text{ cm.}^{-1}$  could be assigned to the C-OH and N-OH stretching vibrations.

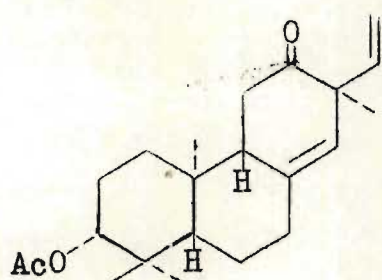

XCI

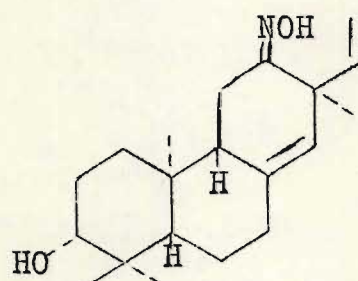

XCII

However, the failure of the ketol, II, to produce a red colouration with alkaline triphenyltetrazolium chloride (113) revealed that the hydroxy group was not located  $\alpha$  to the keto function. This was supported by the fact that the ketol failed to react with sodium metaperiodate solution, and thus the positions of the oxygen functions were deduced chemically and spectroscopically.

### The Double Bonds

The infrared spectrum of the ketol, II, also exhibited olefinic absorptions at  $3085$  and  $1628\text{ cm.}^{-1}$  similar to those encountered for the alcohol, I. However, the determination of the number of double bonds present was complicated by the presence of the carbonyl group.



Mild hydrogenation of the ketol employing a palladium on carbon catalyst in ethanolic medium resulted in the rapid formation of the dihydro derivative,  $C_{20}H_{32}O_2$ , XCIII (a), which on acetylation yielded the acetate,  $C_{22}H_{34}O_3$ , XCIII (b). Under the more drastic hydrogenating conditions in which Adam's catalyst in glacial acetic acid medium were employed the ketol rapidly absorbed one mole of hydrogen, but this was followed by a slower uptake which continued for two days. At the end of this period the calculated volume of hydrogen absorbed was equivalent to three moles. Thus if it was assumed that one mole of hydrogen had been consumed in the reduction of the carbonyl group, the remaining two moles must have been used to reduce two olefinic linkages. The presence of two double bonds in the ketol, II, was substantiated by performing a Huang-Minlon reduction (99) to remove the carbonyl function. The resulting alcohol was characterised as being identical to I, and hydrogenation under high pressure over Adam's catalyst in glacial acetic acid gave rise to the tetrahydro alcohol, LXXIX. This established unambiguously that the ketol, II, possessed the ent-isopimara-8(14),15-diene skeleton and furthermore, that the hydroxy group was located at C-3. It therefore remained to determine the position of the keto function.

In the infrared spectrum of the dihydro-ketol, XCIII (a) (Figure 18) the free hydroxy vibration appeared at  $3542\text{ cm.}^{-1}$  together with a broad band at  $3285\text{ cm.}^{-1}$  attributable to some degree of hydrogen bonding. The C-H stretching

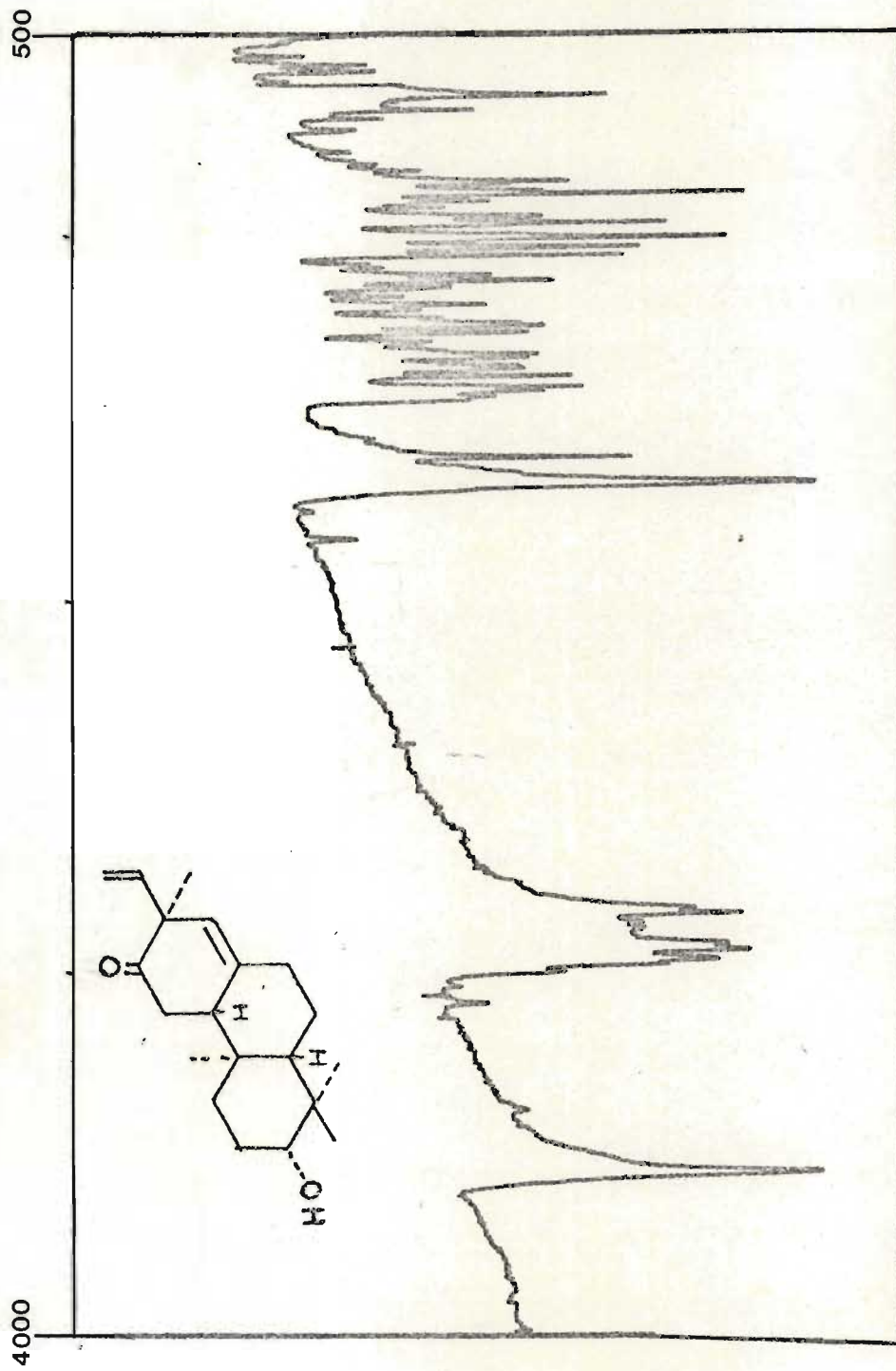

FIGURE 17 IR SPECTRUM OF 3α-HYDROXY-ent-ISOPIMARA-8(14),15-DIEN-12-ONE

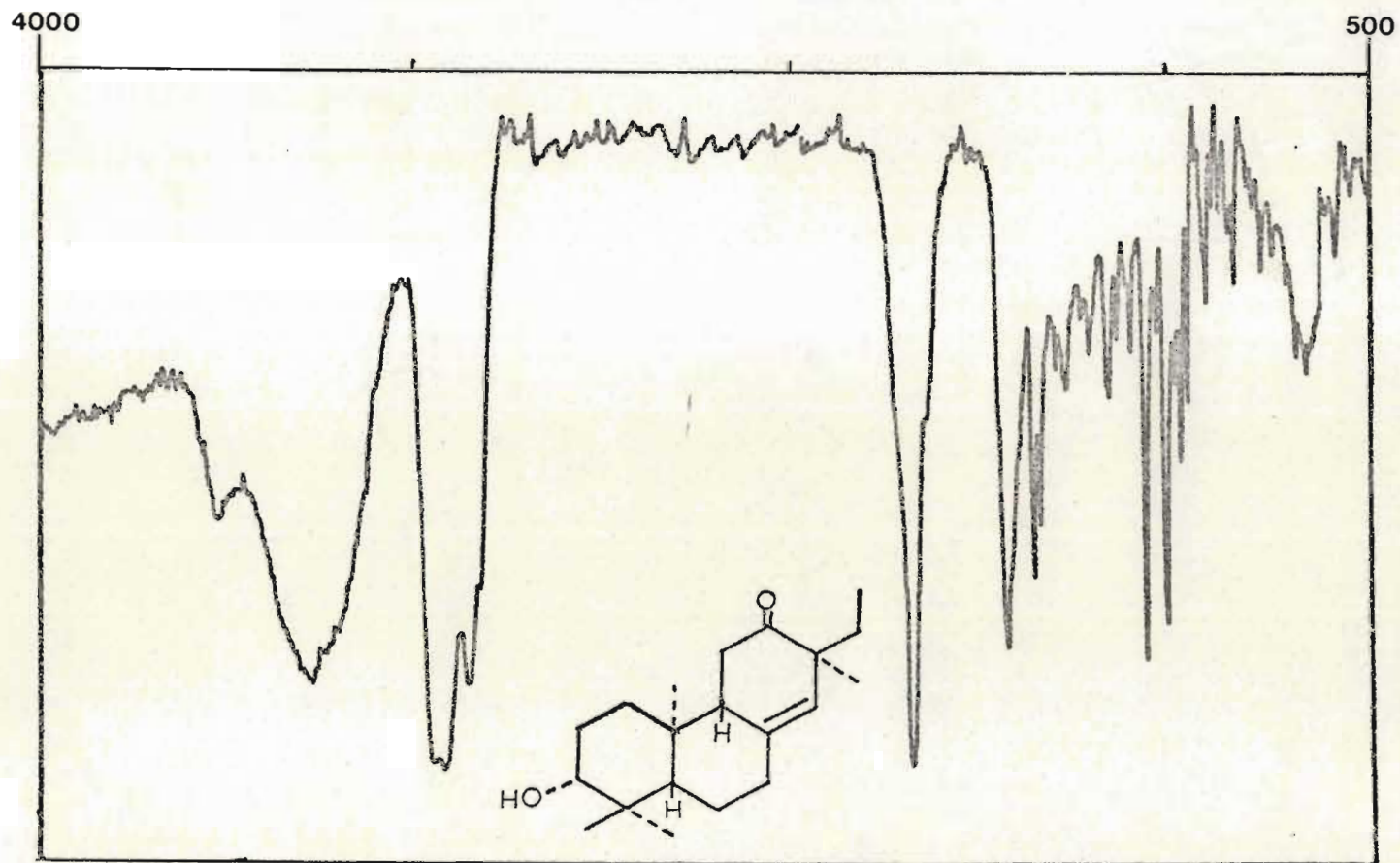
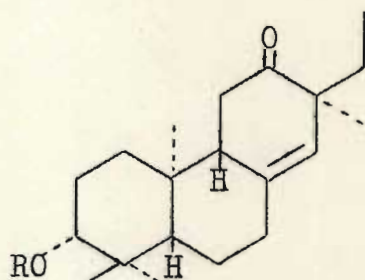

FIGURE 18 IR SPECTRUM OF 3 $\alpha$ -HYDROXY-*ent*-ISOPIMAR-8(14)-EN-12-ONE



vibration of the vinyl group was no longer present, while the C=C absorption of the nuclear double bond occurred at  $1655\text{ cm.}^{-1}$  although somewhat obscured by the intense carbonyl absorption at  $1712\text{ cm.}^{-1}$ . The marked increase in frequency of the latter vibration upon hydrogenation of the vinyl group implied that the keto grouping was affected by the C-15, C-16 double bond and thus that the two substituents were probably in close proximity to each other.



(a) R=H

XCI

(b) R=Ac

The spectrum of the dihydro-acetate, XCI (b) exhibited no hydroxy absorptions and only a weak band at  $1640\text{ cm.}^{-1}$  due to the  $\delta(14)\text{C=C}$  stretching vibration which was almost concealed by the intense band at  $1700\text{ cm.}^{-1}$  due to the ketone absorption. An intense acetate carbonyl stretching vibration occurred at  $1725\text{ cm.}^{-1}$  accompanied by the characteristic ester C-O vibration at  $1242\text{ cm.}^{-1}$ .

#### Location of The Oxygen Functions

Reduction of the ketol, II, with lithium aluminium hydride or sodium in pentyl alcohol resulted in a diol which was chromatographically indistinguishable from the third

unknown compound, III. The facts that both the ketol and the synthetic diol failed to react with glycol splitting reagents and that no ethylidenedioxy derivative could be obtained from the diol implied the absence of a 1,2 or 1,3 oxygenation pattern. Furthermore, the diketone,  $C_{20}H_{28}O_2$ , XCIV, formed on Jones' oxidation of the ketol, II, did not enolise.

The infrared spectrum of the diketone, XCI, exhibited a double absorption in the carbonyl region at  $1695\text{ cm.}^{-1}$ , but this did not facilitate the determination of the ketone positions in the molecule. Stretching vibrations due to the terminal methylene group and to the C=C bonds occurred as usual at  $3078$  and  $1625\text{ cm.}^{-1}$  respectively.

However, the ultraviolet absorption spectrum of the diketone, XCIV, in which a maximum appeared at  $295\text{ nm.}$  ( $\log \epsilon 2.32$ ) and failed to undergo any shift on the addition of a base, confirmed that the oxygen functions were not present as  $\alpha$ - or  $\beta$ -diketo systems (114). Since the hydroxy group in the ketol, II, had been located at C-3, this evidence indicated that the carbonyl function was not situated at C-1 or C-2. In addition, the ultraviolet absorption spectrum of the ketol exhibited a maximum at  $300\text{ nm.}$  ( $\log \epsilon 2.28$ ) which is not in the region characteristic of  $\alpha,\beta$ -unsaturated ketones. The position of this absorption in fact suggested that the carbonyl group was in close proximity to a number of alkyl groups or ring junctions, since it has been found that alkyl substitution in cyclohexanone displaces



the  $n \rightarrow \pi^*$  band to wavelengths higher than the usual 285 nm. (115). Due to the absence of  $\alpha, \beta$  unsaturation C-7 could thus be eliminated as a possible site for the keto group, leaving C-6, C-11 or C-12 as the remaining positions. Of these C-6 was considered most unlikely since steric hindrance of carbonyl groups in this position renders them extremely resistant to Huang-Minlon reduction (116).

The most satisfactory method of establishing the position of the keto group was by the formation of an  $\alpha, \beta$ -unsaturated ketone whose structure could be determined unambiguously from its u.v. and n.m.r. spectra. This method has been employed by Jefferies *et al* (76) who determined the position of the C-12 oxygen function in 12  $\beta$ , 17-dihydroxy-16 $\alpha$ -(-)-kauran-19-oic acid, LXIX.

In the present investigation the ketol acetate, XCI, was completely hydrogenated over Adam's catalyst yielding an alcohol,  $C_{22}H_{38}O_3$ , XCV, from which the carbonyl group was regenerated by oxidation with Jones' reagent to give 3 $\alpha$ -acetoxy-ent-isopimaran-12-one,  $C_{22}H_{36}O_3$ , XCVI. The  $\alpha$ -bromoketone,  $C_{22}H_{35}BrO_3$ , XCVII, was produced upon treatment of the ketone, XCVI, with a solution of bromine in acetic acid and a trace of saturated hydrogen bromide solution (76). Dehydrobromination of this compound was most efficiently effected by refluxing its dimethylformamide solution with a mixture of lithium bromide and lithium carbonate (76), to afford the  $\alpha, \beta$ -unsaturated ketone,  $C_{22}H_{34}O_3$ , XCVIII.



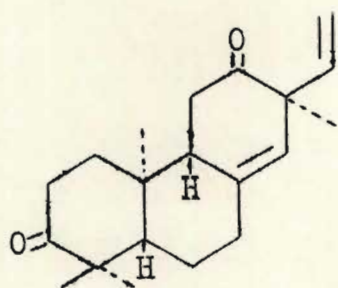

XCV

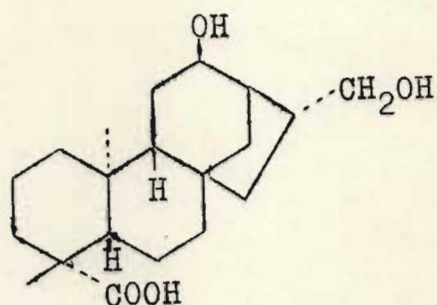

LXIX

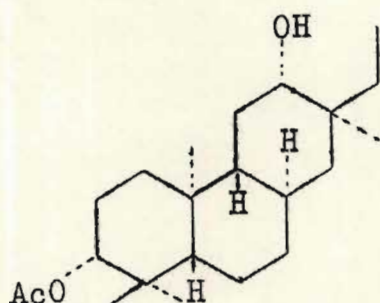

XCV

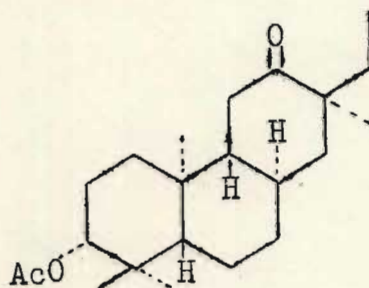

XCVI

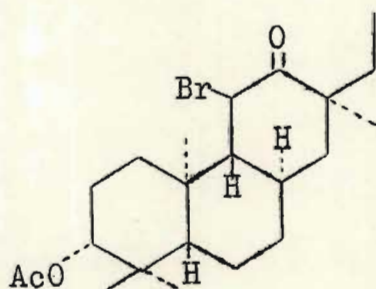

XCVII

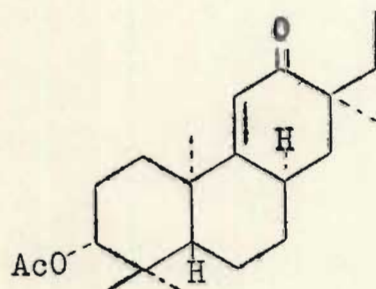

XCVIII

The infrared spectrum arising from the alcohol, XCV, displayed no olefinic absorptions as expected, but a sharp band due to the hydroxy function appeared at  $3510\text{ cm.}^{-1}$  together with the acetate carbonyl and ester C-O vibrations at  $1718$  and  $1240\text{ cm.}^{-1}$  respectively.

The disappearance of the hydroxy band and the appearance of a new intense band at  $1700\text{ cm}^{-1}$  in the spectrum of the ketone, XCVI indicated that oxidation of XCV had regenerated the required ketone.  $\alpha$ -Bromination produced a broadening of the carbonyl band and a slight bathochromic shift to  $1695\text{ cm}^{-1}$  in the spectrum of the  $\alpha$ -bromoketone, XCVII. This effect, due to the strongly electronegative character of the bromine atom, indicated the axial orientation of the bromine (109) but not its location in the molecule.

Its ultraviolet absorption spectrum, however, was most useful in determining the configuration of the bromo- group. Cookson (117) had shown that in conformationally rigid steroid and triterpenoid ketones, a distinction could be made between axial and equatorial bromine on the  $\alpha$ -carbon atom. In general an axial substituent caused an average bathochromic shift of 28 nm. while an equatorial substituent produced an average hypsochromic shift of 5 nm. Thus the maximum at 325 nm. ( $\log\epsilon$  1.89) in the u.v. spectrum of the  $\alpha$ -bromoketone compared with the maximum at 300 nm. ( $\log\epsilon$  1.52) for the parent ketone indicated that the bromine was axially orientated, giving rise to 3 $\alpha$ -acetoxy-11 $\beta$ -broment-isopimaran-12-one, XCVII.

The infrared spectrum of the  $\alpha,\beta$ -unsaturated ketone, XCVIII, exhibited its carbonyl stretching frequency at  $1657\text{ cm}^{-1}$  and new absorptions due to the conjugated double bond at  $3048$  and  $1603\text{ cm}^{-1}$  in agreement with expectation. Ratios of the C=O band intensity to the C=C band intensity



have been employed in establishing the conformation of  $\alpha,\beta$ -unsaturated ketones (118) and in this case the value of approximately 3 falls within the range of 0.6-3.5 for cisoid ketones. Furthermore, in the ultraviolet absorption spectrum an intense maximum at 241 nm. ( $\log \epsilon$  4.16) was in fair agreement with the value of 245 nm. calculated on the basis of the Woodward rules (119) for a 9(11)-en-12-one.

### Nuclear Magnetic Resonance Spectra

A study of the n.m.r. data accumulated for the ketol and its derivatives has confirmed many of the structural assignments made. From the n.m.r. spectrum of the ketol, II, (Figure 19) it was obvious that the olefinic double bond systems were identical to those present in the C-3 alcohol, I. The quartet centred at  $\tau$ 4.25 arose from the resonance of the C-15 vinyl proton which formed the X part of an ABX system (observed coupling constants were  $J_{\text{trans}}$  18 Hz,  $J_{\text{cis}}$  10 Hz), while the two non-equivalent C-16 protons constituted the AB part and gave rise to a multiplet at  $\tau$ 4.89 (observed geminal splitting  $J_{\text{gem}}$  1.5 Hz). However, the C-14 proton resonance at  $\tau$ 4.76 showed no detectable allylic coupling which was perhaps indicative of the location of the carbonyl group in the C-ring causing a conformational deviation which was not conducive to allylic interaction between the protons at C-14 and C-9.

The C-3 proton adjacent to the hydroxy group



resonated as a multiplet at  $\tau$ 6.76 (observed axial-equatorial splitting approximately 6 Hz) which was consistent with its assigned axial orientation (96). In the region around  $\tau$ 7.5 a multiplet occurred arising from signals due to protons adjacent to the carbonyl function and the allylic C-7 methylene protons, but this splitting pattern could not be readily analysed.

The signals of the four methyl groups at C-13, C-4 equatorial and axial and C-10 resonated as singlets at  $\tau$ 8.78, 8.87, 9.20 and 9.29. A comparison of these values with those for the alcohol, I, showed that the introduction of a keto- group caused a deshielding of the C-13 methyl group by 0.17 p.p.m. and a shielding of the C-10 methyl group by 0.10 p.p.m. These effects could be explained by the anisotropy of a carbonyl group at C-12 (76).

In the spectrum of the ketol acetate, XCI, the only significant differences were those caused by acetylation. The C-3 proton shifted predictably downfield to  $\tau$ 5.5 and exhibited axial-equatorial splitting of the order of 6 Hz which was indicative of the equatorial configuration of the acetate moiety (96). An intense singlet at  $\tau$ 7.96 was also attributable to the acetate methyl protons.

The spectrum of the dihydroketol, XCIII (a), differed from that of the ketol by the significant absence of signals due to the C-15 and C-16 vinyl protons. This resulted in a spectrum with an uncomplicated olefinic region

displaying a singlet at  $\tau$ 4.7 due to the C-14 proton. The methyl region presented a somewhat more complex splitting pattern since hydrogenation of the C-15(16) double bond resulted in a primary methyl group at C-16 which resonated as a partially concealed triplet centred at  $\tau$ 9.2.

Acetylation of the dihydroketol gave rise to a spectrum in which the C-3 proton signal shifted downfield to  $\tau$ 5.5 and a new singlet appeared at  $\tau$ 7.98 due to the acetate methyl group.

The saturated nature of the tetrahydro ketone, XCVI, was confirmed by the absence of any signals in the olefinic region of its n.m.r. spectrum. A quartet at  $\tau$ 7.8 could be attributed to the two non-equivalent methylene protons adjacent to the carbonyl group since this resonance disappeared on  $\alpha$ -bromination of the ketone. The methyl region of the spectrum was very similar to that discussed in the spectrum of the dihydro compound.

The spectrum of the  $\alpha$ -bromoketone, XCVII, (Figure 20) proved to be very important diagnostically. From the study (105) of a large number of  $\alpha$ -haloketones an interesting observation was that the chemical shift of hydrogens attached to the halogen bearing carbon atom occurred in the region between  $\tau$ 4.9 - 6.0. Furthermore, the signal for an equatorially orientated hydrogen was found to resonate at higher field than its epimer bearing an axially orientated proton. This reversal of the usual axial-equatorial relationship discussed in the spectra of the alcohols and acetates has



been reported for several pairs of epimeric  $\alpha$ -bromocyclohexanones (106). Thus in the case of this  $\alpha$ -bromoketone, XCVII, the doublet at  $\tau$ 6.0 indicated that the bromine was in the axial configuration, thereby substantiating the evidence provided by the ultraviolet absorption spectrum discussed earlier. The observed splitting of 4 Hz was consistent with the range (1 - 5 Hz) for vicinal axial-equatorial interaction (104). Since splitting was observed a distinction could be made between C-11 and C-12 as possible sites for the carbonyl group if the C-6 position was discounted. Had the keto-function been located at C-11, bromine substitution at C-12 would have resulted in a singlet due to the C-12 proton whilst bromination at C-9 would not have produced a signal in this region. If the C-6 position was considered a likelihood for the keto-function the same resonance would have arisen, but it will be shown at a later stage that this site did not satisfy all the requirements.

From a consideration of molecular models the chair conformation is probably the most stable conformation for the tetrahydroketone, XCVI, to adopt. If the addition of bromine occurs by the usual mechanism, then the bromine would approach the molecule from the sterically least hindered side. Since the C-11 site is considerably hindered by the C-10 axial ( $\alpha$ ) methyl group, approach by the bromine will be from the opposite face of the molecule. This requires that bromine approaches from the  $\beta$  side, and this reaction would produce the 11 $\beta$ -bromo compound with ring C



in the boat conformation. This conformation is preferred to the theoretically more stable situation where the bromine atom would be in the equatorial configuration and ring C in the chair conformation (108). The formation of the latter product is not favoured because of the severe interaction which would occur between an equatorial C-11 bromine and the equatorial C-1  $\alpha$ -hydrogen. Supporting evidence of the fact that the bromine is  $\beta$ -orientated was provided by the shift in the C-10 methyl signal in the n.m.r. spectrum. If the axial bromine had been in the  $\alpha$ -configuration a deshielding of the C-10 methyl group should have been observed (76, 120), but instead there was a small degree of shielding from  $\tau$ 9.13 in the tetrahydro ketone, XCVI, to  $\tau$ 9.22 in the  $\alpha$ -bromoketone, XCVII.

The n.m.r. spectrum of the  $\alpha,\beta$ -unsaturated ketone, XCVIII, exhibited a doublet at  $\tau$ 4.31 due to the vinylic proton  $\alpha$ - to the carbonyl group. This splitting (2 Hz) could be attributed to allylic coupling between the C-11 and C-8 protons. From a consideration of molecular models the dihedral angle between these two protons almost certainly fell within the range of  $60 - 110^\circ$  which would give rise to the predicted (93, 94) and observed magnitude for such coupling constants.

A multiplet at  $\tau$ 7.4 was probably due to the C-8 allylic proton while there was no significant change in the pattern of splitting of the methyl signals.

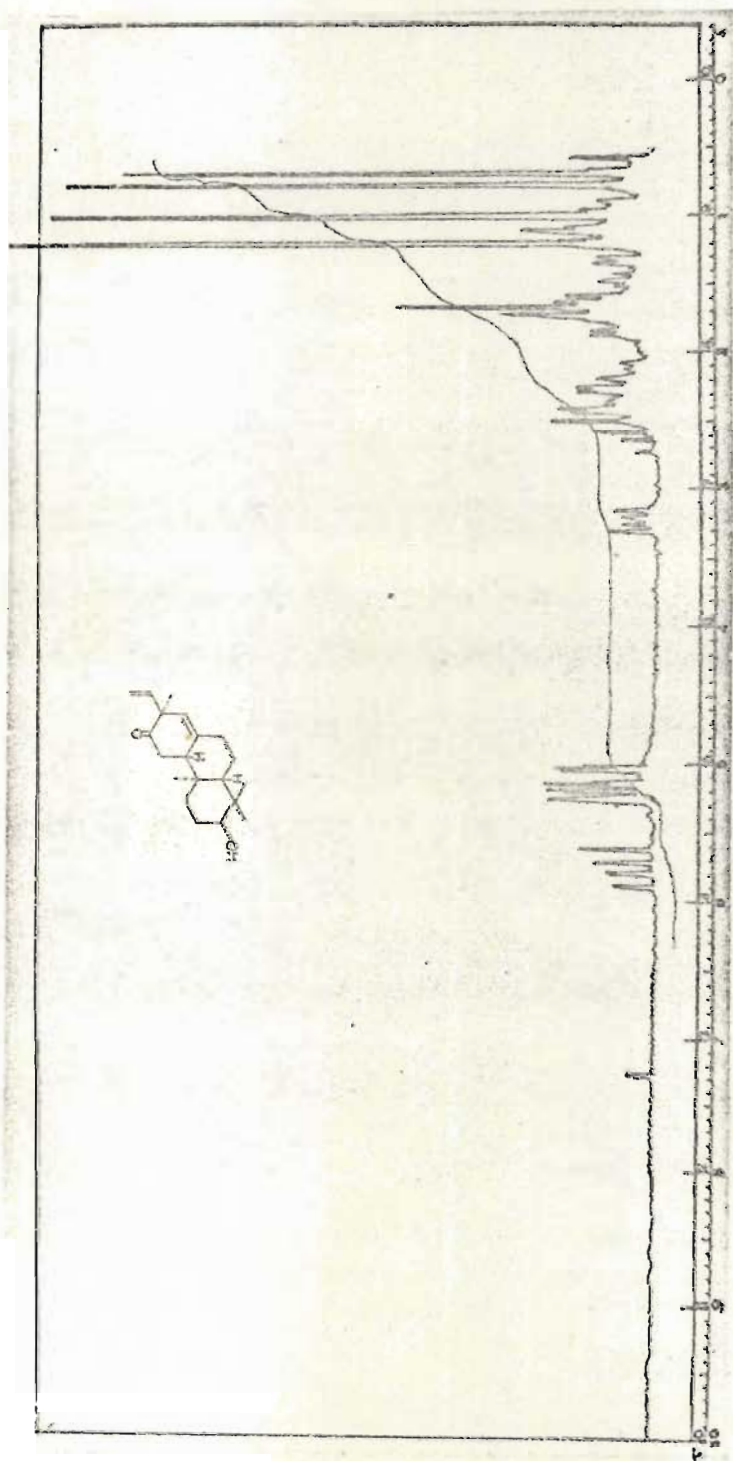

FIGURE 19 NMR SPECTRUM OF 3 $\alpha$ -HYDROXY-ent-ISOPIMARA-8(14),15-DIEN-12-ONE

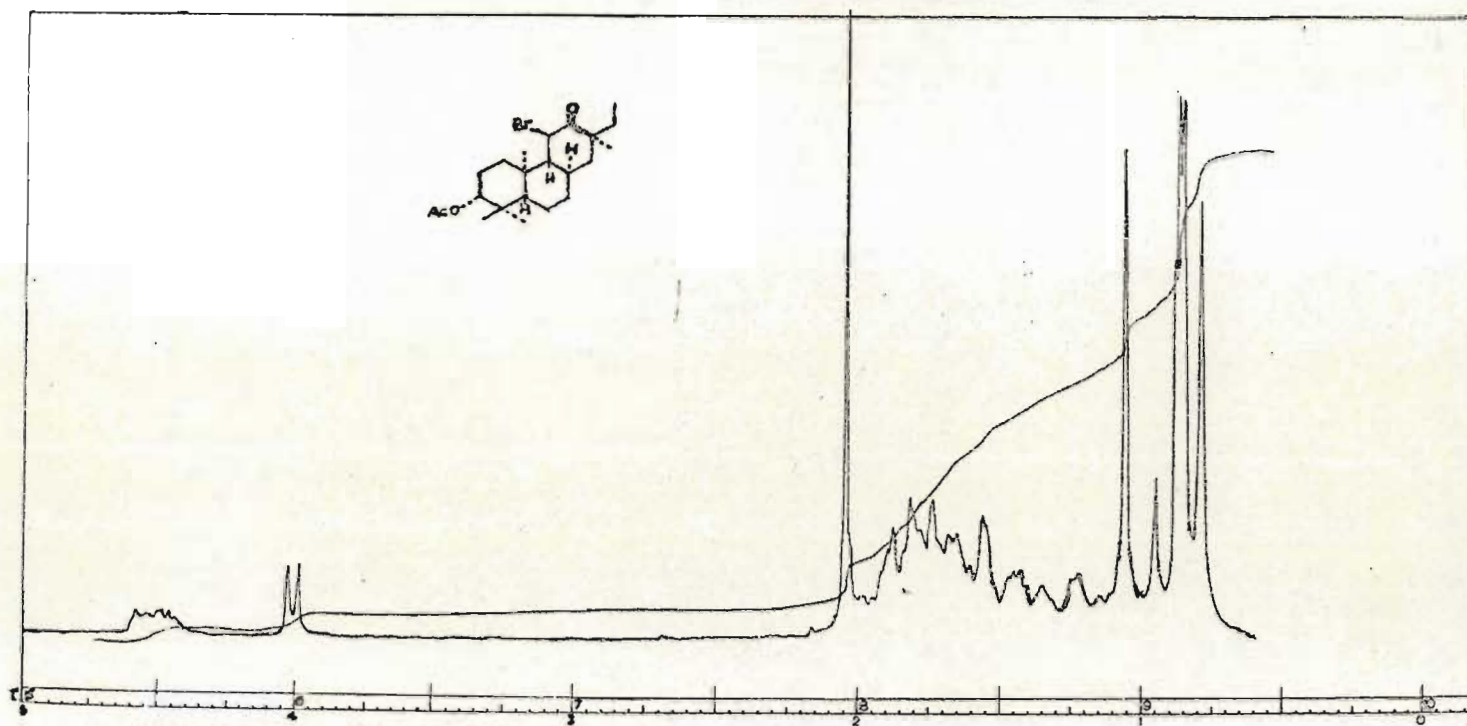

FIGURE 20 NMR SPECTRUM OF 3 $\alpha$ -ACETOXY, 11 $\beta$ -BROMO-ent-ISOPIMARAN-12-ONE



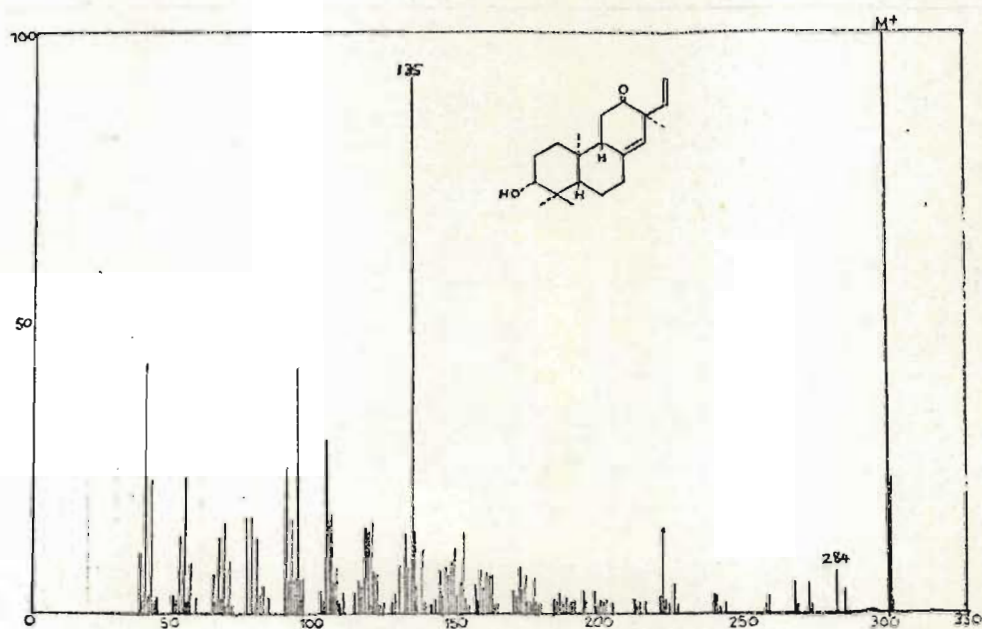

FIGURE 21 MASS SPECTRUM OF 3 $\alpha$ -HYDROXY-ent-ISOPIMARA-8(14),15-DIEN-12-ONE

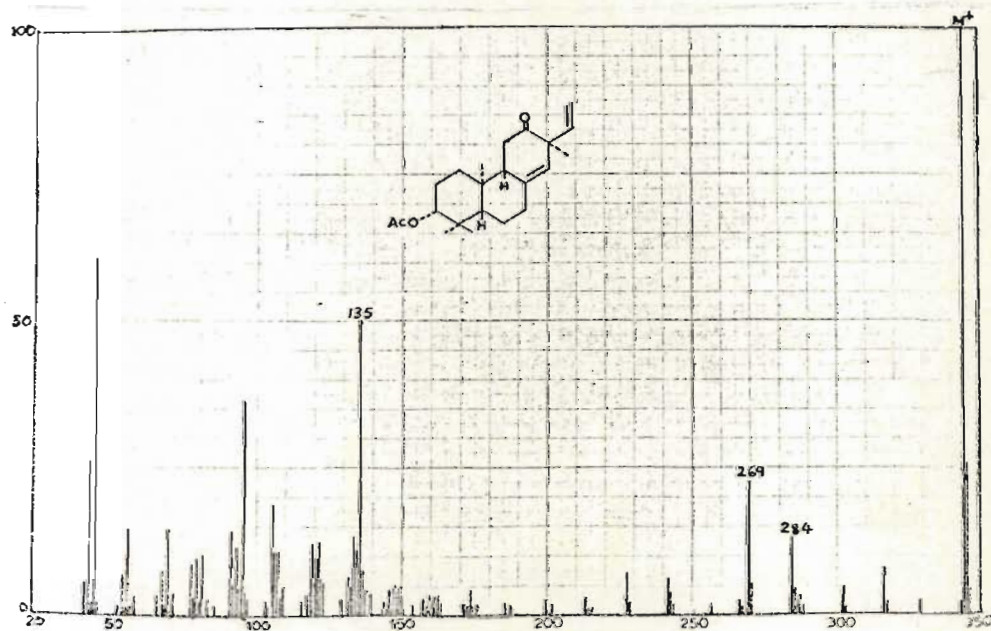

FIGURE 22 MASS SPECTRUM OF 3 $\alpha$ -ACETOXY-ent-ISOPIMARA-8(14),15-DIEN-12-ONE

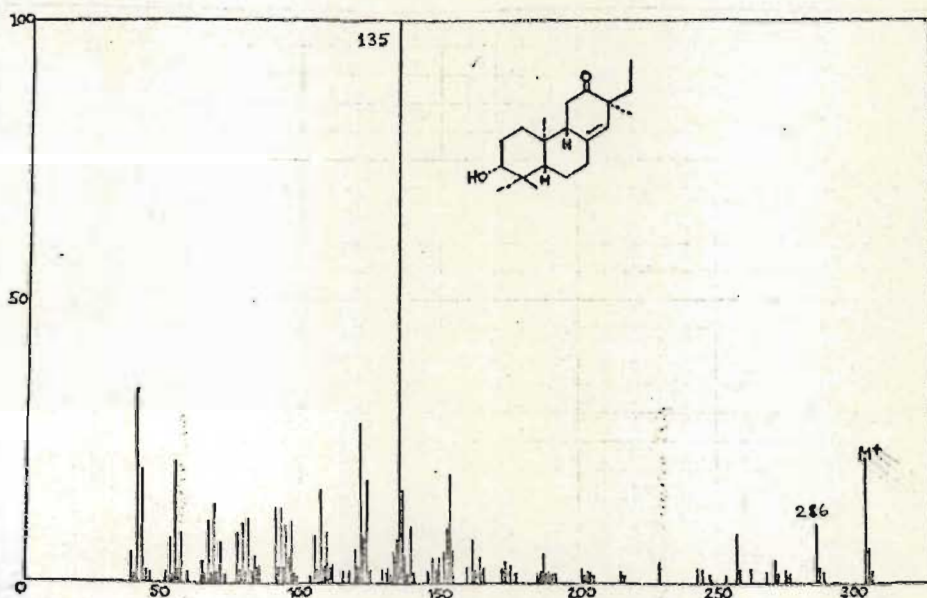

FIGURE 23 MASS SPECTRUM OF 3 $\alpha$ -HYDROXY-ent-ISOPIMAR-8(14)-EN-12-ONE

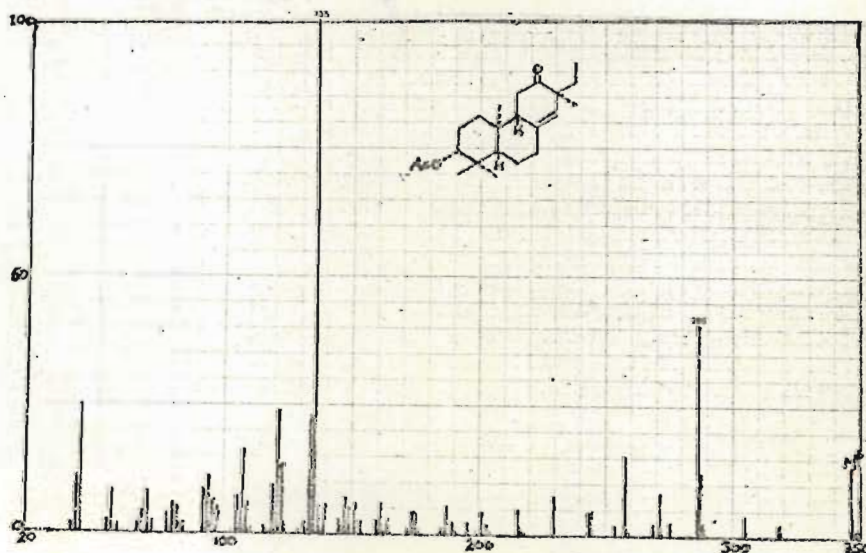

FIGURE 24 MASS SPECTRUM OF 3 $\alpha$ -ACETOXY-ent-ISOPIMAR-8(14)-EN-12-ONE



## Mass Spectra

The spectra of the ketol, II, and its derivatives displayed fragmentation patterns which were very similar to those of the alcohol, I, and its derivatives discussed in the previous section.

Significant differences were only apparent in the upper half of the spectrum of the ketol (Figure 21) where the molecular ion at  $m/e$  302 formed the base peak and marked decreases in the M-15 ( $m^*$  273, 302  $\rightarrow$  287) and M-33 ions were noted. In the spectra of both the ketol and its acetate (Figure 22) there was a complete absence of the M-27 fragment due to the loss of the C-13 vinyl group, whilst in the spectra of their dihydro derivatives (Figures 23 and 24) there was a large decrease in the abundance of the M-29 fragment. The decreased intensities in these ions which are formed by the loss of a C-13 alkyl substituent were not unexpected since the loss of one of these groups would give rise to a positive charge  $\alpha$ - to the carbonyl group. Due to the electron withdrawing effect of a carbonyl group the positive charge would not be delocalised, and thus the formation of these ions was not a favoured process.

In addition to these changes in intensity three "new" fragments occurred at M-28, M-42 and M-75. The first of these may be explained by the elimination of carbon monoxide by the favoured fission of the bonds adjacent to the carbonyl group (121). This fragmentation was confirmed



by a metastable peak at  $m/e$  249 (302 274).

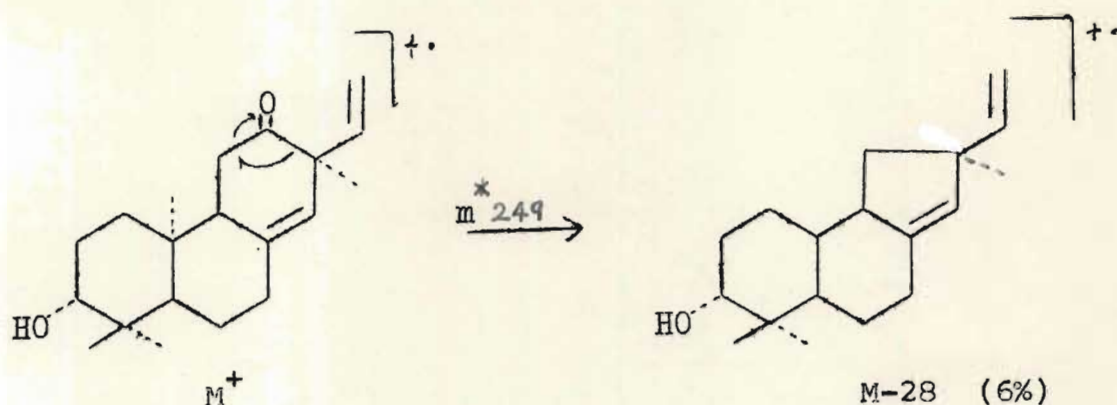

The formation of the  $M-42$  fragment probably arose from the molecular ion by a Retro-Diels-Alder fragmentation leading to the elimination of the carbonyl group and the  $\alpha$ -methylene group as ketene. Fission of the bond  $\beta$ - to the carbonyl group is usually a less favoured process than fission of the  $\alpha$ -bond, and in accordance with this the  $M-42$  fragment was present in slightly lower abundance than the  $M-28$  ion in the spectrum of the parent ketol, II.

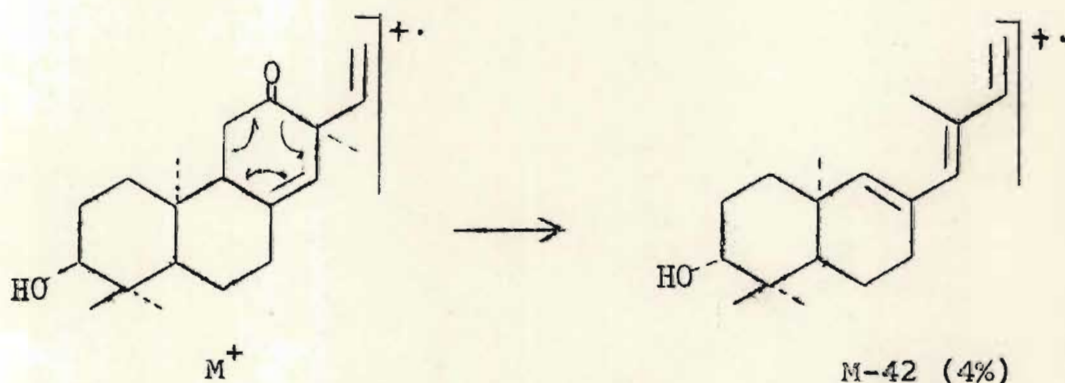

Finally, the  $M-75$  fragment could be explained by one of two possible fragmentations. The first would involve the loss of the elements of water and the C-10 methyl group

from the M-42 ion as shown below, while a second process would involve the loss of ketene from the M-18 ion by the mechanism outlined above to give a M-60 ion (not present in the spectrum) which would then rapidly lose the C-10 allylic methyl group to produce the M-75 ion. Of the two possible pathways, the former was preferred.

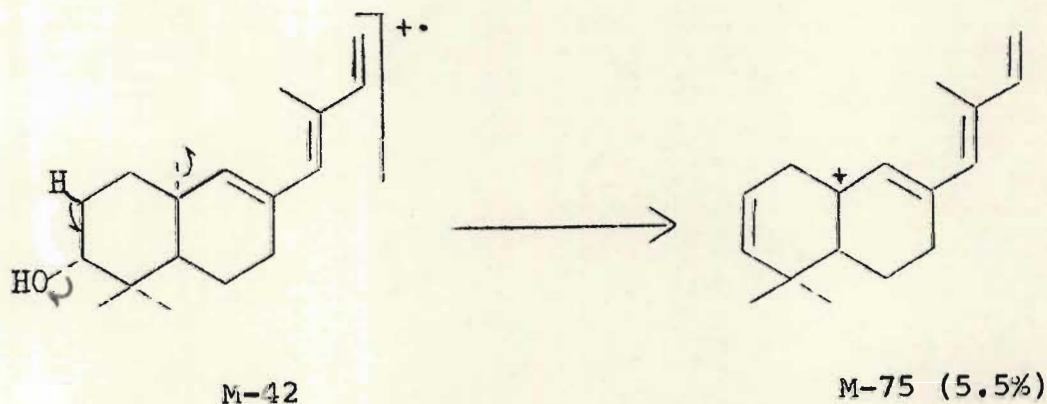

A peak appearing at  $m/e$  148 in the spectrum of the alcohol, I, was absent in the spectrum of the ketol, but replaced by a peak at  $m/e$  133 (M-169) which was derived from the M-28 ion by a process similar to that explained for the formation of the  $m/e$  148 fragment from the alcohol, I, and is illustrated on page 94.

In the spectrum of the ketol acetate, XCI, (Figure 22) the molecular ion which again formed the base peak appeared at  $m/e$  344. The main differences in fragmentation, however, were the replacement of the M-18 fragment by an M-60 ion and the M-(18+15) ion by the relatively abundant M-(60+15) ion (22.5%).

A scheme of the overall fragmentation of the ketol, II, and its acetate, XCI, is shown in Scheme 5.

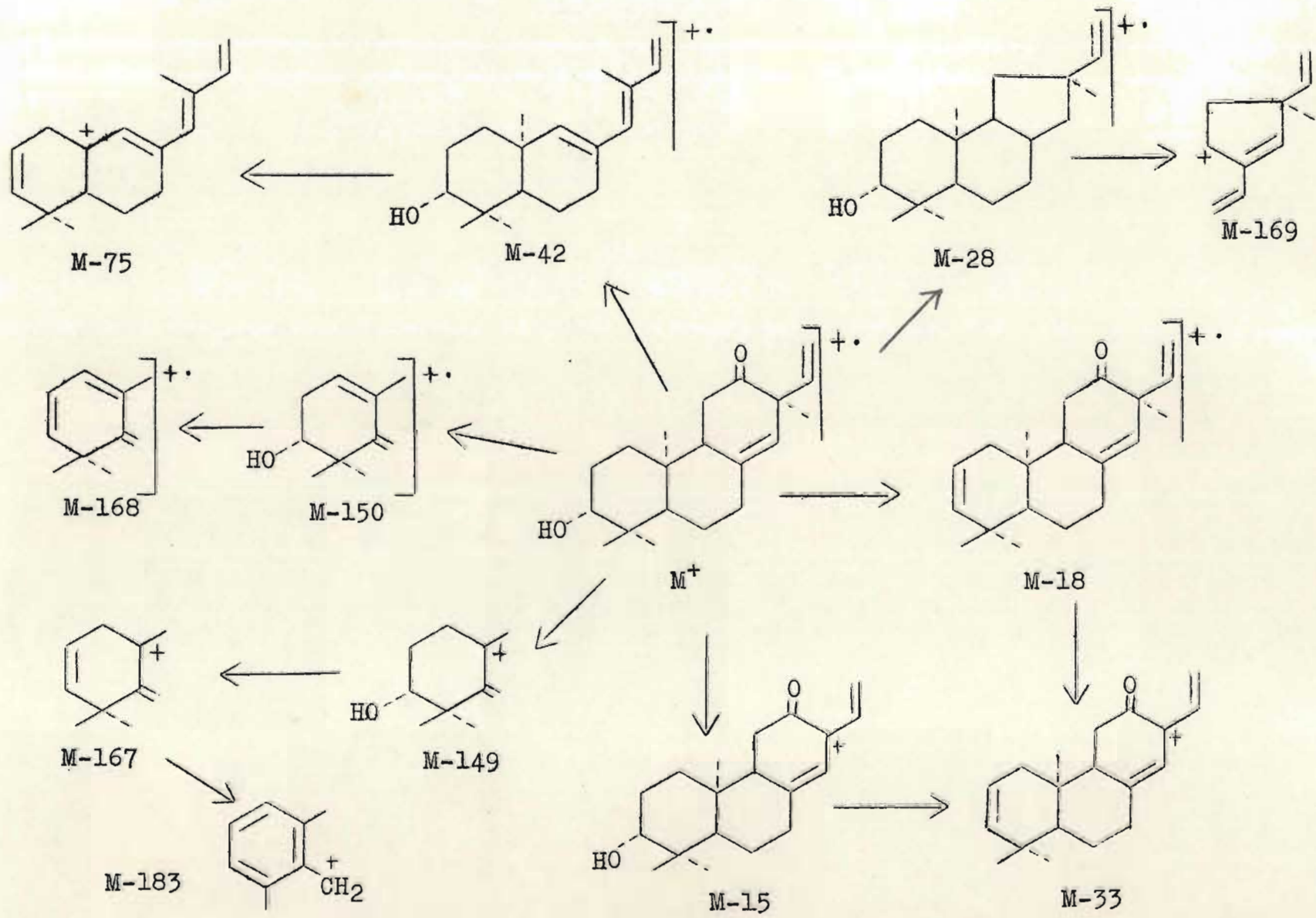

SCHEME 5



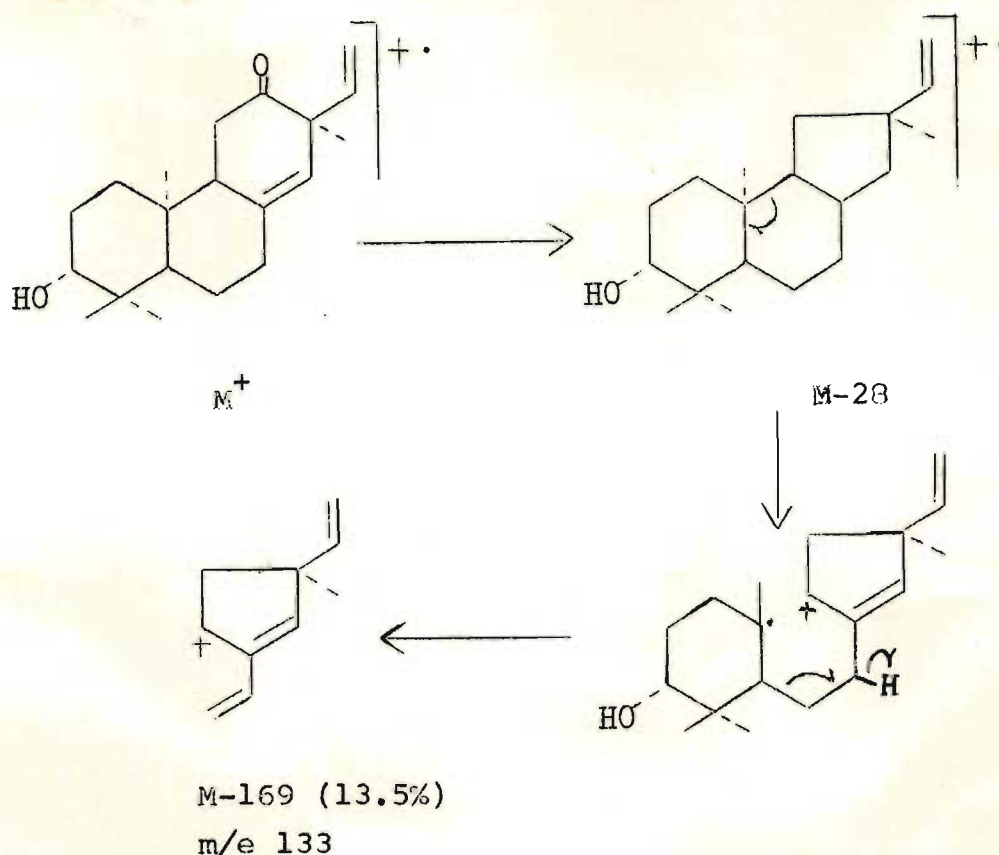

The spectrum of the tetrahydroketol acetate, XCVI, displayed the molecular ion at  $m/e$  348 (66.5%) as well as a number of prominent peaks in the upper half of the spectrum. Since the mechanisms for the formation of these fragments have already been discussed, the proposed structures for the most significant ions are shown in Scheme 6.

In the spectrum of the  $\alpha$ -bromoketone, XCVII, there were two molecular ion peaks at  $m/e$  426 and 428 due to the presence in the molecule of two isotopes of bromine ( $Br^{79}$  and  $Br^{81}$ ) in approximately equal abundance. The spectrum was relatively simple and exhibited prominent peaks at  $M-60$  and  $M-80$  arising from the loss of the elements of acetic acid and hydrogen bromide respectively. (page 96)

## SCHEME 6

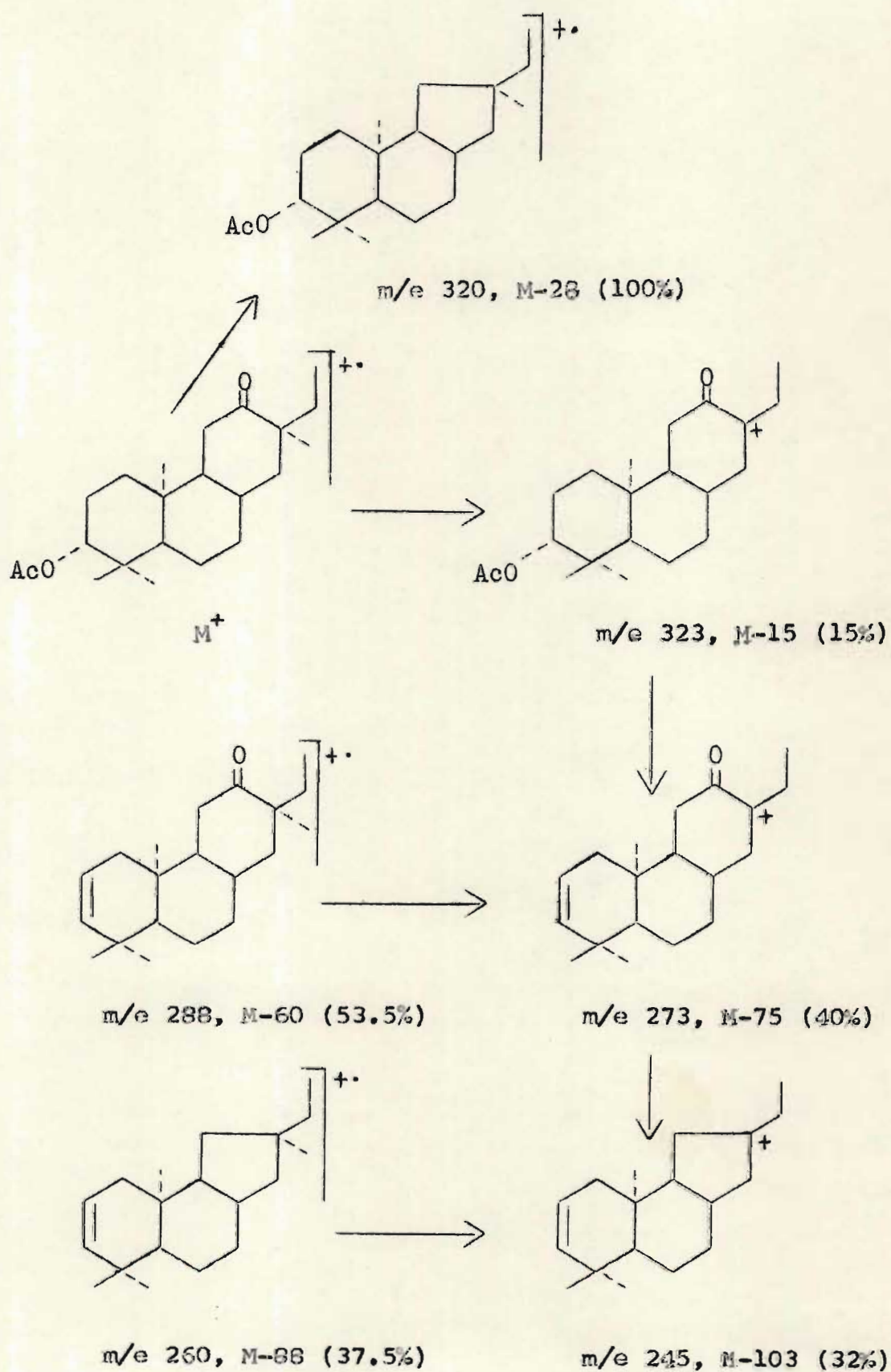

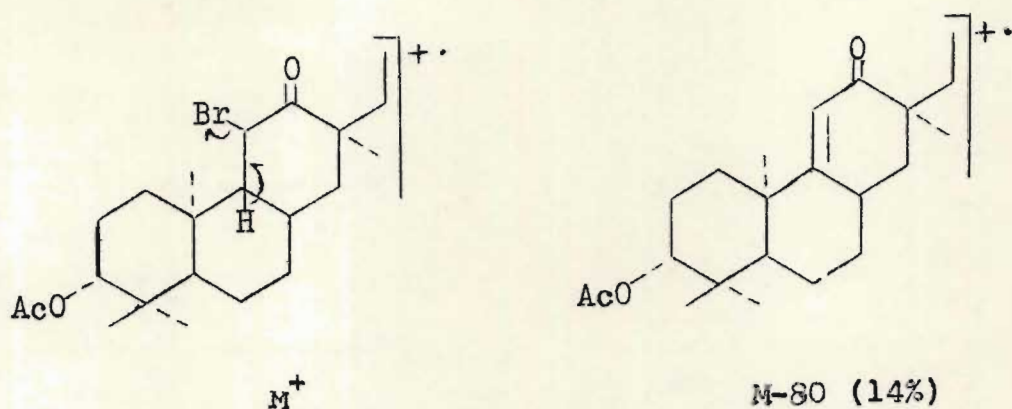

The loss of carbon monoxide from the M-80 ion would account for a prominent ion at M-108, from which an allylic methyl group could readily be lost from C-10 or C-13 to produce the ion at M-123.

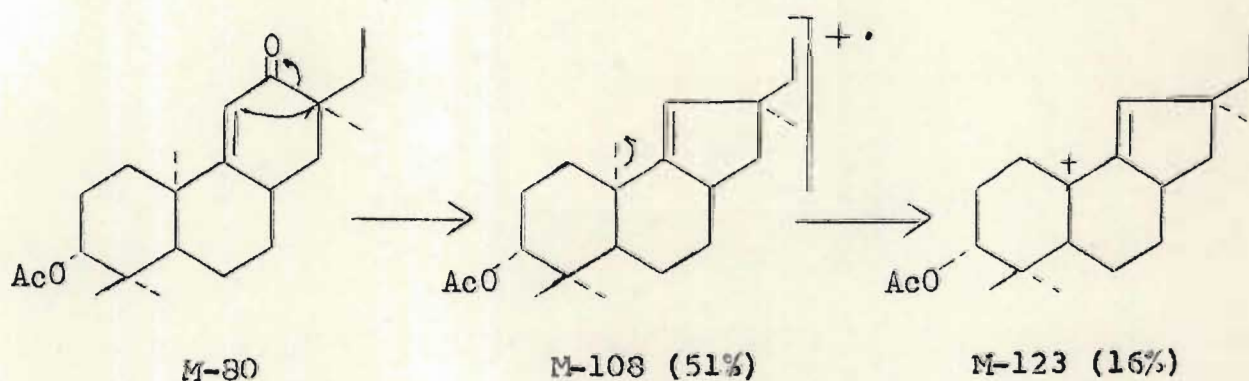

An intense ion at M-141 probably arose from the M-60 ion by loss of the bromine atom. If this ion then underwent the loss of a molecule of carbon monoxide then this would have resulted in the ion at M-169. (page 97)

The mass spectrum of the  $\alpha,\beta$ -unsaturated ketone, XCVIII, was extremely simple with the molecular ion occurring at  $m/e$  346. The most significant ions were those which appeared as M-28 and M-60 fragments. The former ion which



arose by the loss of the elements of carbon monoxide as shown by the metastable peak at  $m/e$  292.6 ( $346 \rightarrow 318$ ) formed the base peak in the spectrum. Another metastable ion at  $m/e$  289 indicated that a methyl group had been eliminated from the M-28 ion to produce the fragment at  $m/e$  303 (M-43). This process was probably similar to that outlined for the analogous ion in the previous spectrum. As usual the M-60 ion could be explained by the loss of the elements of acetic acid by the McLafferty rearrangement. The remainder of the spectrum was very similar to all the spectra previously discussed, although the ions were present in much lower abundance.

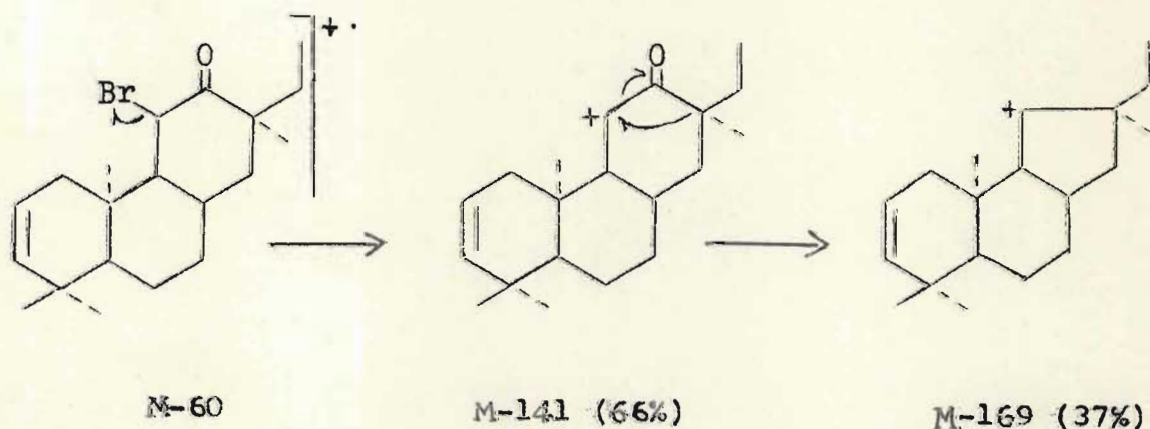

1.3.  $3\alpha, 12\alpha$ -Dihydroxy-*ent*-isopimara-8(14), 15-diene, III.

The third compound to be isolated chromatographically in this series was obtained in lower yield than the ketol, II, and comprised approximately 0.1% of the heartwood. It has been identified as  $3\alpha, 12\alpha$ -dihydroxy-*ent*-isopimara-

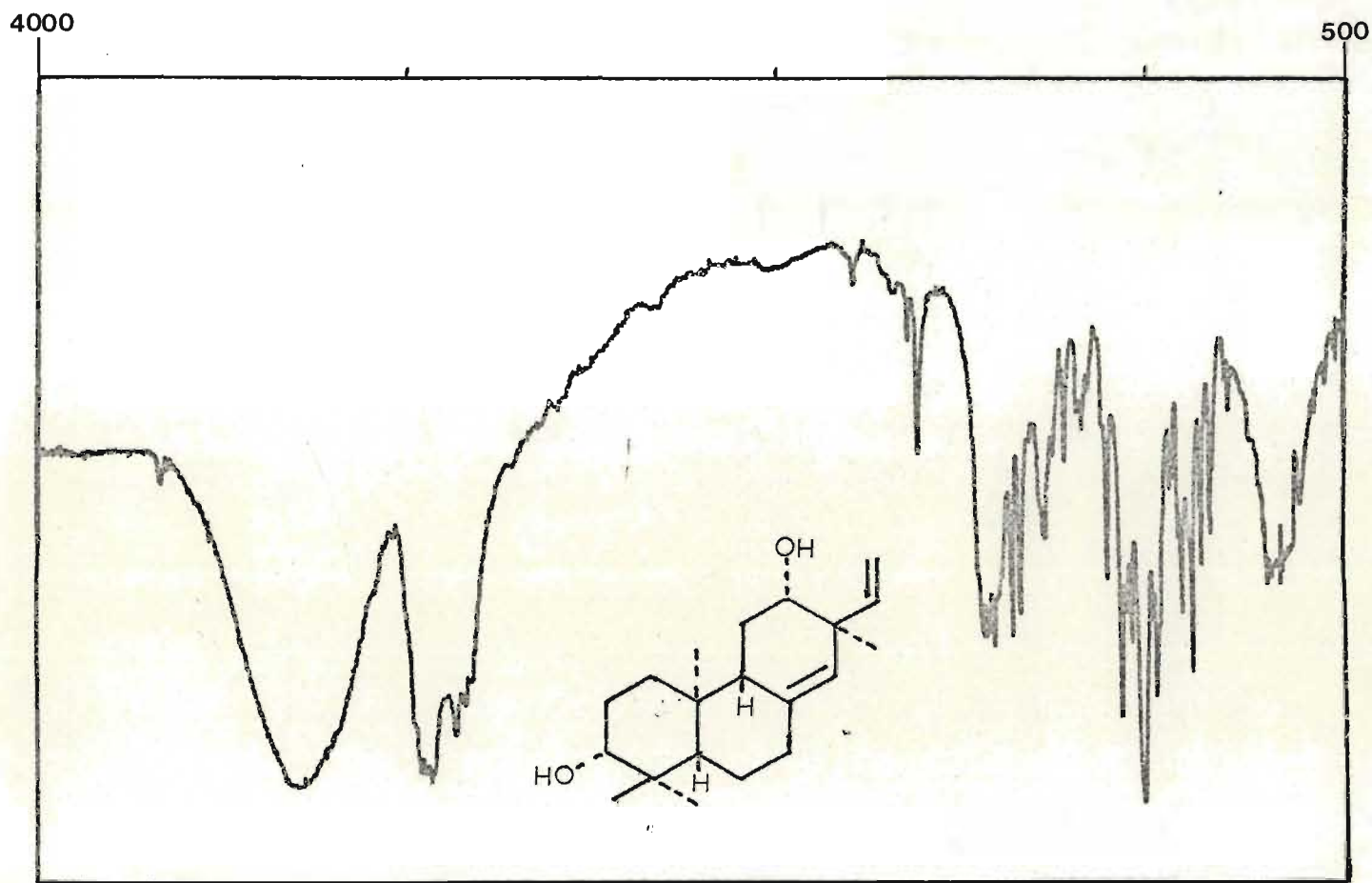

FIGURE 25 IR SPECTRUM OF 3 $\alpha$ ,12 $\alpha$ -DIHYDROXY-ent-ISOPIMARA-8(14),15-DIENE



8(14),15-diene, III, by establishing its relationship with the ketol and by a study of its spectral data.

Except for the tetranitromethane test the usual colour reactions failed to provide any indication as to the nature of the functional groups. However, evidence regarding the diterpenoid character of the compound was indicated by its molecular formula of  $C_{20}H_{32}O_2$ . The infrared spectrum of this diterpene III, (Figure 25) exhibited no carbonyl absorption, but a broad hydroxy band was evident at  $3290\text{ cm}^{-1}$ . This suggested that both oxygen functions were present as hydroxy groups. Confirmation of this was provided by the conversion of the diol, III, to the diacetate, XCIX. Furthermore, the failure of the diol to react with periodic acid showed that the two hydroxy groups were not vicinal. Jones' oxidation of the diol, III, afforded a diketone which was found to be identical in all respects to the diketone, XCIV, obtained by a similar oxidation of the ketol, II. The formation of the diketone established that both the basic skeletons and the sites of oxygenation of the ketol and the diol were identical.

A comparison of the n.m.r. spectra of the ketol and the diol confirmed the similarity of their skeletons. The spectrum of the diol (Figure 26) exhibited a quartet at  $\tau 4.22$  and a multiplet centred at  $\tau 4.93$  characteristic of the C-13 vinyl ABX system (observed  $J_{\text{trans}} 18\text{ Hz}$ ,  $J_{\text{cis}} 10\text{ Hz}$ ,  $J_{\text{gem}} 1.5\text{ Hz}$ ). The singlet at  $\tau 4.83$  due to the C-14 proton was partially obscured by the AB multiplet.



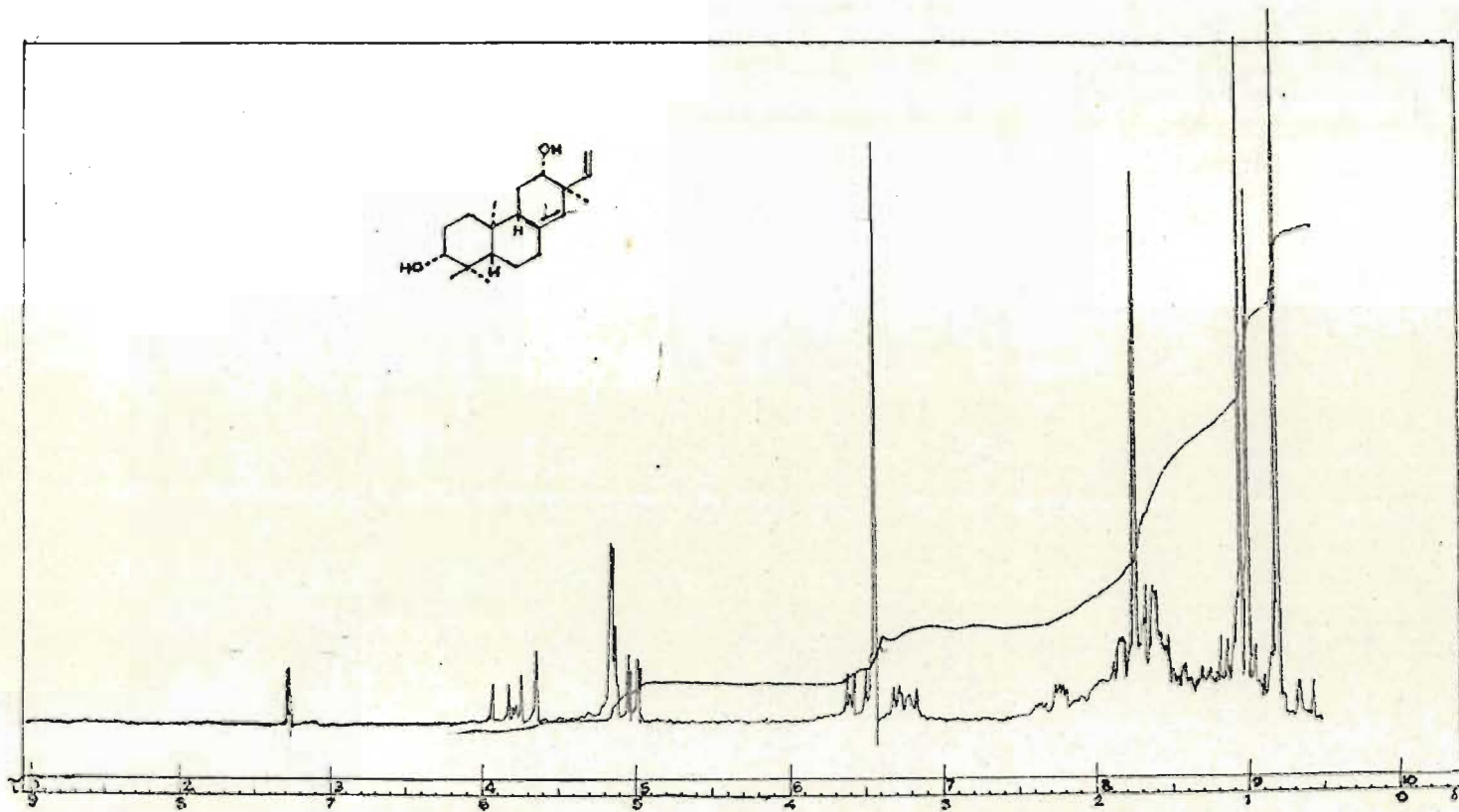

FIGURE 26 NMR SPECTRUM OF 3 $\alpha$ ,12 $\alpha$ -DIHYDROXY-*ent*-ISOPIMARA-8(14),15-DIENE

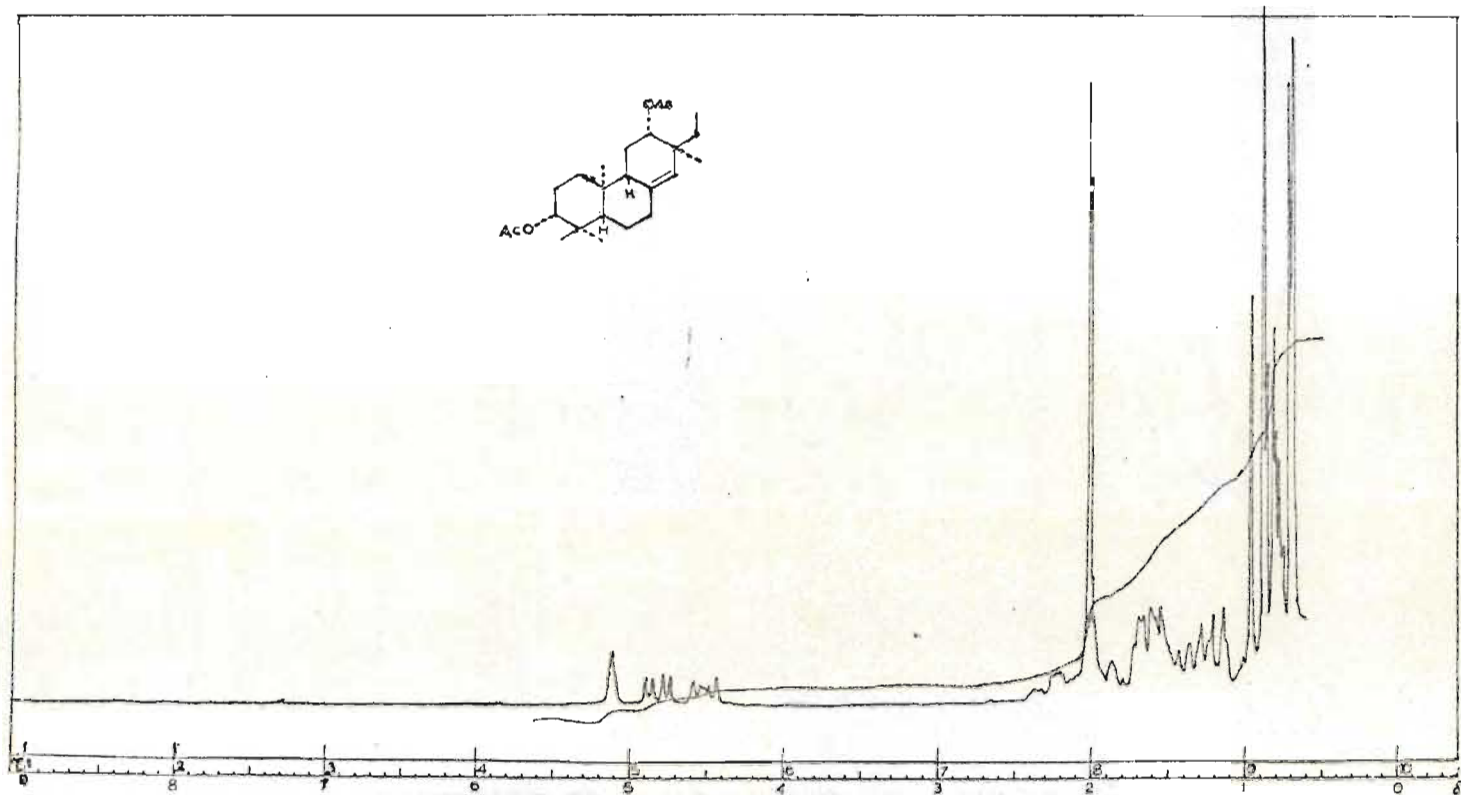

FIGURE 27 NMR SPECTRUM OF 3 $\alpha$ ,12 $\alpha$ -DIACETOXY-ent-ISOPIMAR-8(14)-ENE

Most significant were the signals due to the protons adjacent to the hydroxy groups. The C-3 axial proton resonated as usual as a multiplet at  $\tau$ 6.75 which is in good agreement with the chemical shift for this signal ( $\tau$ 6.73) in the spectrum of the alcohol, I. A broad multiplet at  $\tau$ 6.45 was assigned to the proton adjacent to the second hydroxy group, but this signal was partially obscured by a hydroxy proton signal at  $\tau$ 6.54. This signal together with another at  $\tau$ 8.24 was removed by exchange with deuterium oxide, thereby simplifying the multiplet at  $\tau$ 6.45.

On acetylation of the diol the C-3 and C-12 proton signals shifted from  $\tau$ 6.75 and 6.45 to  $\tau$ 5.48 and 5.19 respectively. However, this did not clarify the situation as the signal at  $\tau$ 5.19 was now complicated by part of the vinyl multiplet in this region. In order to overcome this problem the diol was hydrogenated over palladium on carbon in ethanol or over Adam's catalyst in acetic acid to produce a dihydro-, C (a), or tetrahydro-derivative, CI, respectively. Acetylation of the dihydrodiol, C (a), afforded the dihydrodiacetate, C (b), whose n.m.r. spectrum (Figure 27) exhibited a multiplet at  $\tau$ 5.49 due to the C-3 proton and an ABC quartet at  $\tau$ 5.19 due to a proton adjacent to two non-equivalent protons. Since it was established that the positions of oxygenation in the ketol, II, and the diol, III, were identical and furthermore, that the carbonyl function in the ketol was located at probably C-12 or only tentatively at C-6, it followed that the second hydroxy group in the diol



must also be situated at either of these two positions. It was obvious from the observed quartet due to the proton adjacent to this hydroxy group that such a signal could only have arisen if the oxygen function was located at C-12. Had the hydroxy function been in the C-6 position a more complex signal would have been expected due to coupling with the C-5 and C-7 protons. Thus in the diol, III, the functional groups were located at C-3 and C-12, which therefore confirmed that in the ketol, II, the carbonyl group was at C-12.

The half-width and chemical shift of the C-3 proton signal were consistent with the axial orientation which had been assigned to the previous congeners discussed. By a similar consideration of the C-12 proton signal it seemed extremely likely that this hydrogen was probably also axially orientated. However, in order to obtain a chemical confirmation of the stereochemistry at C-12 the ketol, II, was stereospecifically reduced with sodium in pentyl alcohol (122, 123) to furnish exclusively the equatorial ( $\alpha$ ) hydroxy compound, which was identical in all respects to the diol, III. In contrast a similar reduction of the ketol, II, using lithium aluminium hydride afforded a mixture of both equatorial and axial isomers of the diol in the ratio of approximately 3:2. Thus the diol has been shown to be  $3\alpha,12\alpha$ -dihydroxy-ent-isopimara-8(14),15-diene, III.

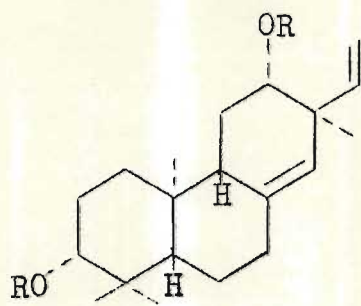

III R=H  
XCIX R=Ac

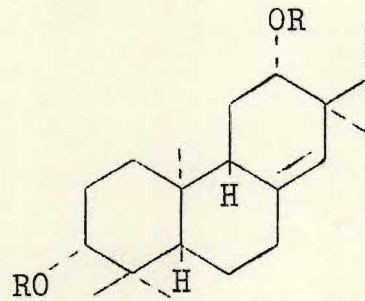

C (a) R=H  
(b) R=Ac

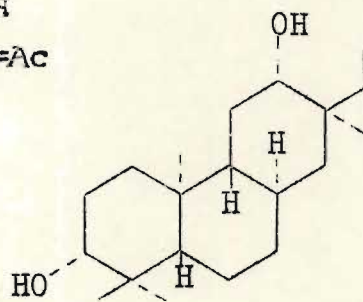

CI

### Mass Spectra

The mass spectrum of the diol, III, displayed a fragmentation pattern which was very similar to that of the alcohol, I. Its molecular ion occurred at  $m/e$  304 in agreement with its molecular formula of  $C_{20}H_{32}O_2$ . The ion at  $m/e$  135 once again formed the base peak in the spectra of the parent diol, III, and its dihydro and acetyl derivatives.

Minor differences which were observed were due to the ions resulting from the elimination of the C-12 hydroxy group. Thus the ion at  $M-44$  for the diol, III, probably arose by a retro Diels-Alder fragmentation of the C ring in the molecular ion and corresponds with the  $M-42$  ion in the spectrum of the ketol, II, (Figure 21). The cleavage mech-

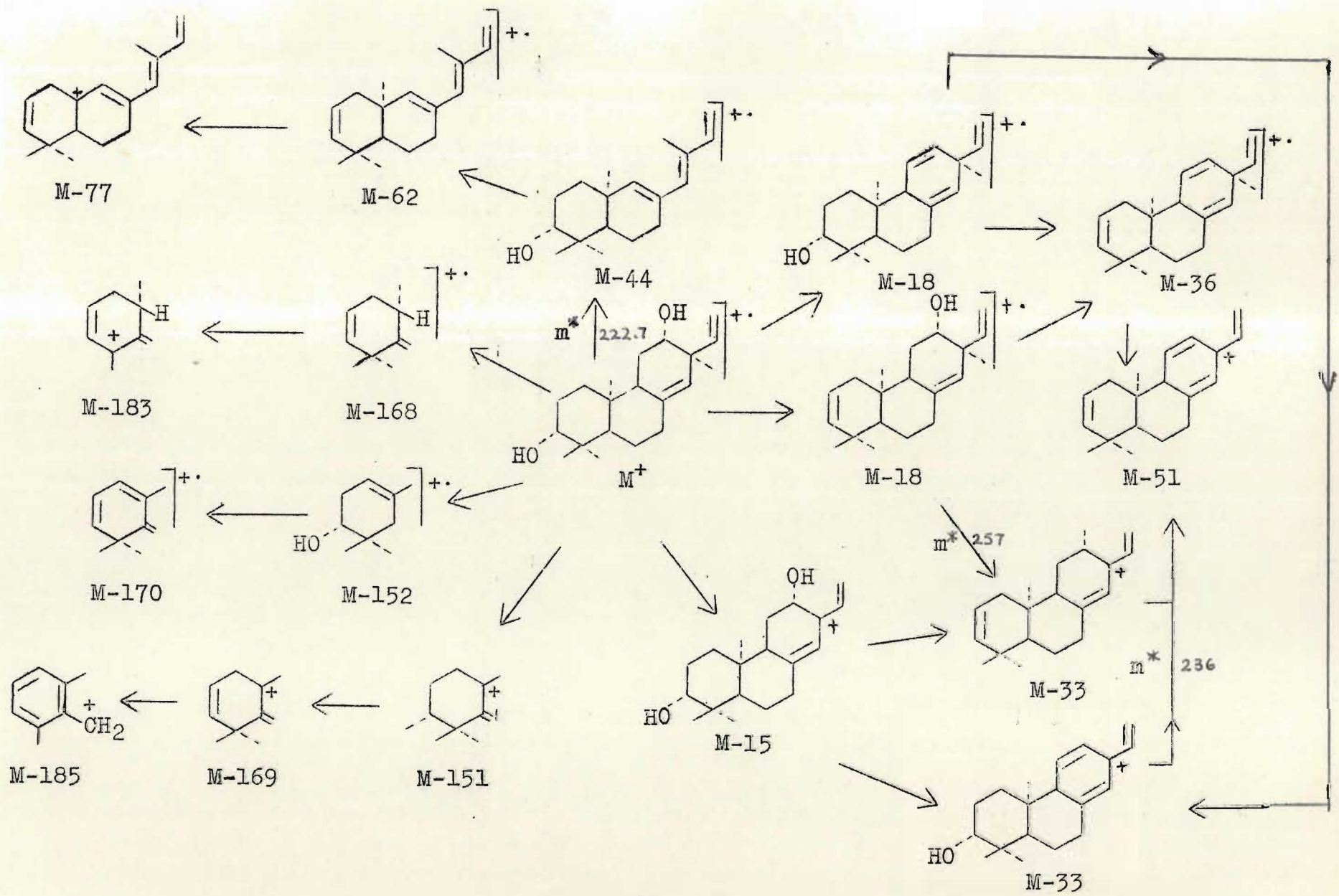

SCHEME 7



anisms giving rise to the other ions have been previously discussed and therefore the overall fragmentation pattern of the diol and its derivatives is illustrated in Scheme 7.

### Biogenetic Discussion

The co-occurrence of the diterpenes I, III, II and IV exhibiting an increasing oxidation state of the C ring provides an interesting series for biogenetic speculation.

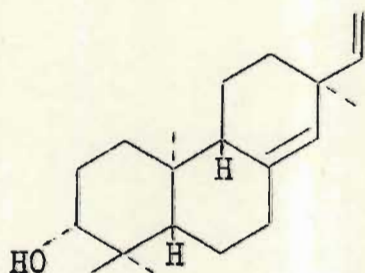

I

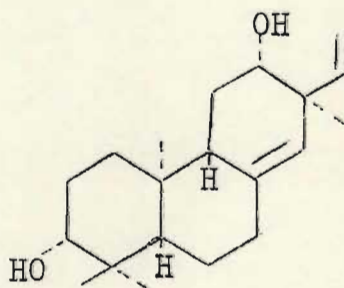

III

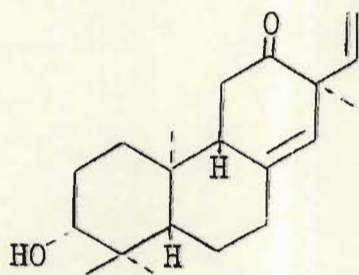

II

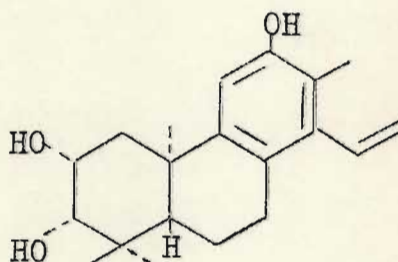

IV

It is suggested that the logical biogenetic pathway involved oxygenation of the alcohol, I, to the diol, III, which in turn may be oxidised to the ketol, II, the precursor of cleistanthol, IV. The aromatisation of ring C of the ketol to give the cleistanth-8,11,13-triene skeleton,

CII, is thought to be initiated by the abstraction of an hydride ion from C-9. Migration of the 8,14-double bond to the 8,9 position together with the transfer of the vinyl group from C-13 and C-14 via a "Claisen" type of intermediate, CIII, and the elimination of a proton from C-14 thus affords the aromatic ring C as outlined below.

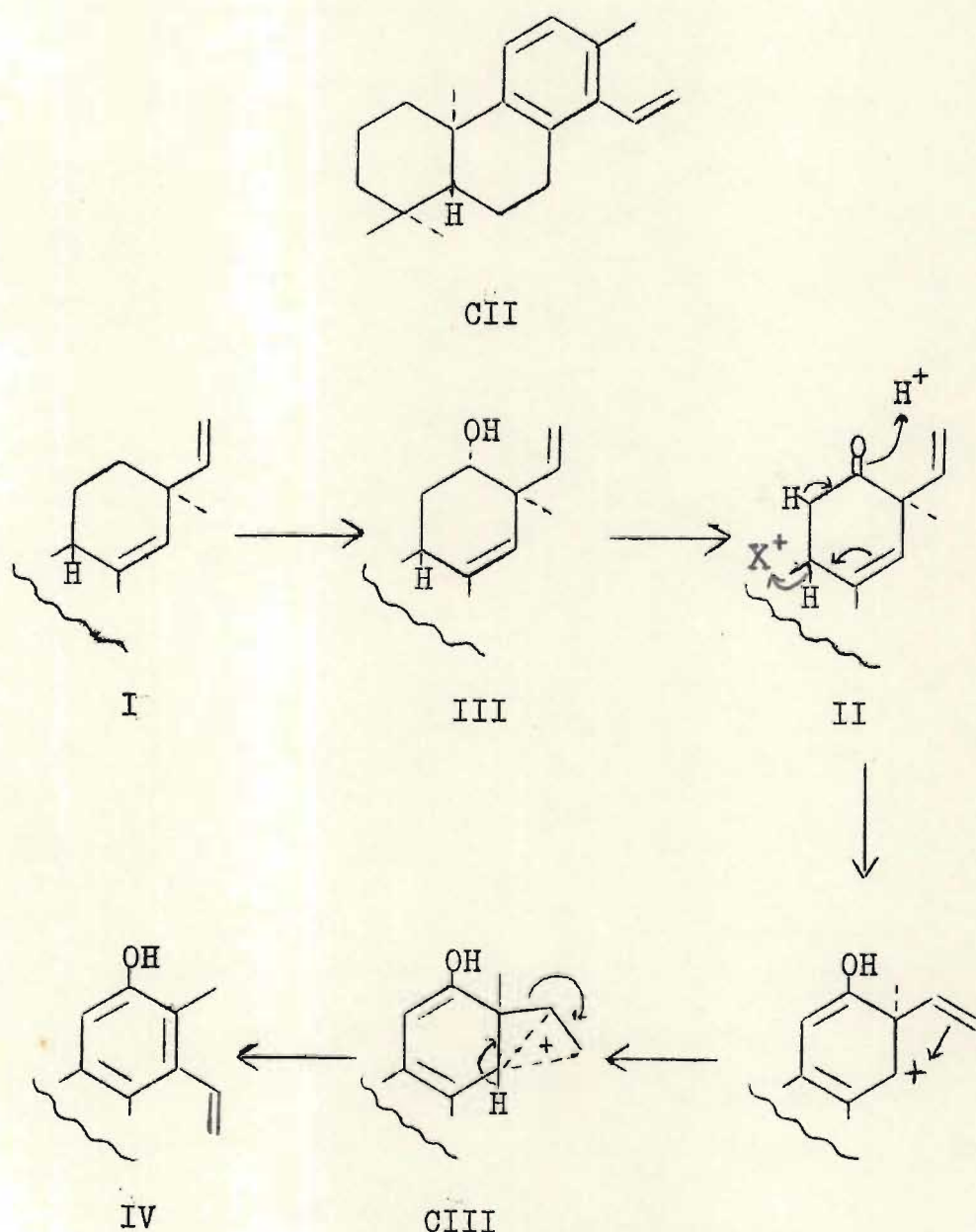

An alternative and tempting sequence for the conversion of the ketol, II, to the phenol, IV, involves the  $\alpha,\beta$ -unsaturated ketone, CIV, as outlined below. Unfortunately, the fact that this compound could not be detected within the extract failed to substantiate this theory.

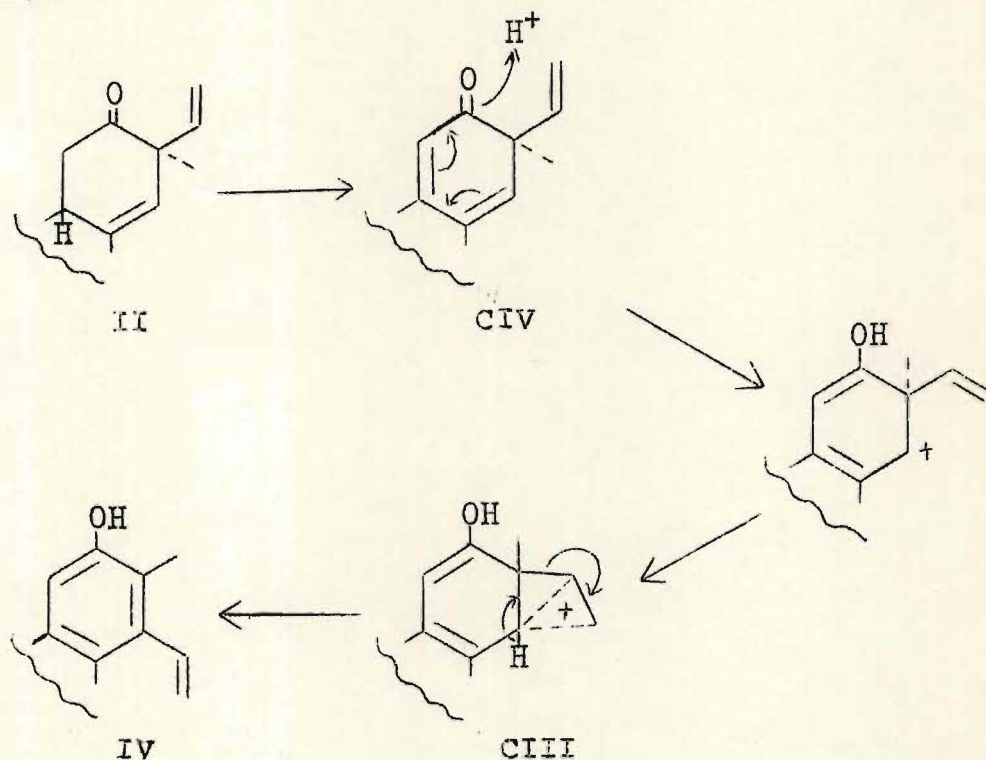

As mentioned in the introduction the pimaradienes are commonly considered (60, 62) to be the biogenetic precursors of the tetracyclic diterpene skeletons. Thus (-)-kaurene, LXX, may be derived from the ent-pimaradiene, CV, as depicted on the next page.

However, due to the epimeric stereochemistry encountered at C-13 in the present series of Cleistanthus compounds isolated, it is considered that the vinyl group



is not favourably orientated for the formation of a tetracyclic skeleton and that migration of this group to C-14 is perhaps a more favoured process. This hypothesis is supported by the occurrence of the hitherto unknown cleistanthane skeleton and the apparent absence of tetracyclic diterpenes so frequently encountered in other species of Euphorbiaceae (e.g. 7,65,68,71,72,74,75).

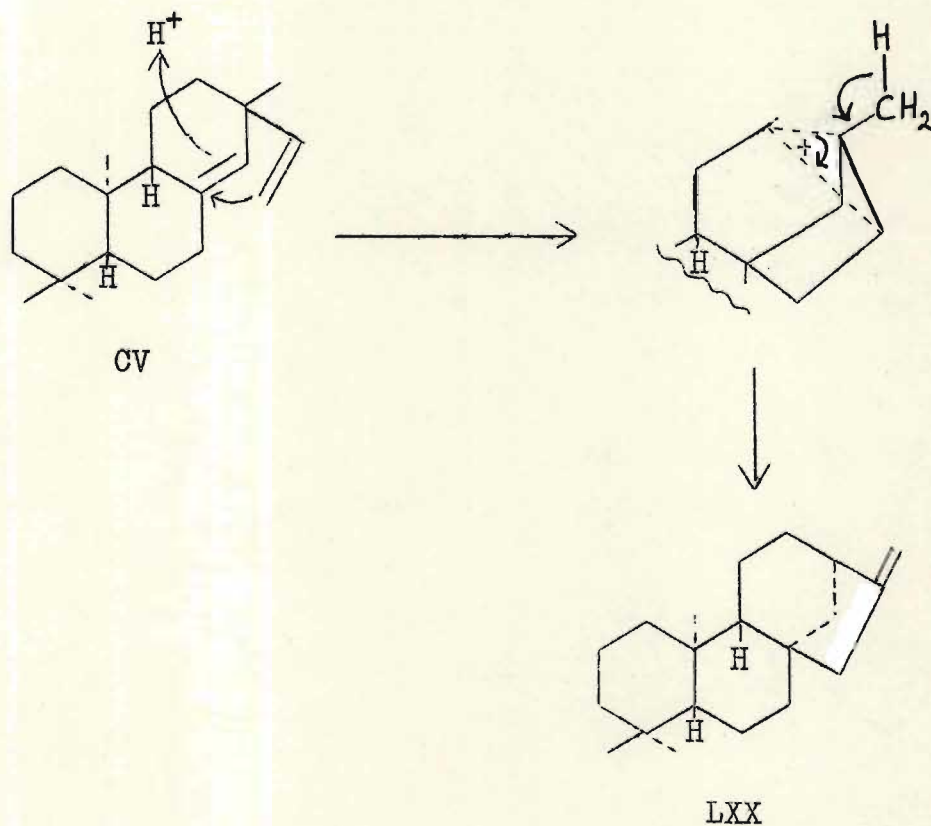

PART 2. THE DITERPENES OF SPIROSTACHYS AFRICANA

During an earlier investigation of the heartwood of Spirostachys africana Sond. (syn. Excoecaria africana Muell. Arg.) the structures of three diterpenoid constituents were elucidated, but it was reported that there remained an acidic fraction which was not investigated (7). An attempt was therefore made to isolate and identify further new compounds from the heartwood in order to compare the species chemotaxonomically with other Euphorbiaceae.

Spirostachys africana which is commonly known as Tambootie or African Sandalwood is a deciduous tree that grows to a height of 20 to 30 feet. It is monotypic and endemic to Africa, being found mainly in Botswana, the Zululand forests, throughout the Transvaal and in East Africa (124). The straight clear trunk which is usually up to 18 ins. in diameter is covered with a rough, almost black bark, fissured into characteristic rectangles. Its sapwood is a pale buff colour while the heavy heartwood is well-defined, rich brown in colour and possesses a distinctive odour. The sawdust from the wood, if allowed to enter the eyes, is known to cause pain and temporary blindness, while the latex is used as a fish poison by the indigenous tribes and the bark is employed as an ingredient in herbal medicines.

The milled, air-dried heartwood of Spirostachys africana was extracted several times with cold light petroleum, and on concentration this yielded a yellow syrup



in which a crystalline solid precipitated. Extraction of the sawdust with boiling light petroleum furnished a darker extract which appeared to be chemically identical with the cold light petroleum extract as monitored by thin layer chromatography.

Preliminary fractionation of the crude extract by means of column chromatography afforded the known ketone, V, ketol, VI, and diosphenol, VII (7). Since the beyerene and stachene skeletons are identical these compounds may be named beyer-15-en-3-one, 3-hydroxybeyer-15-en-2-one and 2-hydroxybeyer-1,15-dien-3-one respectively. Although they were originally reported as stachene derivatives (7), the beyerene nomenclature will be adhered to throughout this section for the sake of consistency.

In order to separate the acidic components, the crude extract was partitioned between light petroleum and 0.1 N aqueous alcoholic potassium hydroxide using the counter-current technique. This led to the isolation of a new di-terpene seco-acid to which the name spirostachic acid was assigned.

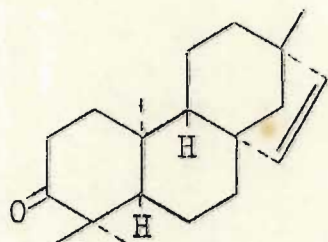

V

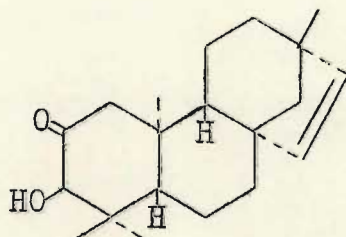

VI

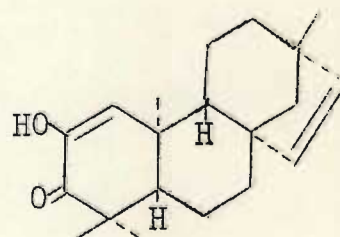

VII



2.1. Beyer-15-en-3-one, V, 3-Hydroxybeyer-15-en-2-one, VI and 2-Hydroxybeyer-1,15-dien-3-one, VII.

Repeated column chromatography of the first fraction followed by recrystallisation of the product provided needles of beyer-15-en-3-one, V, which was identified by comparison of its physical constants and spectral data with those of an authentic sample, and the formation of an identical 2,4-dinitrophenylhydrazone.

Colourless needles of the ketol were collected from the mother liquors of the eluates and identified by a positive triphenyltetrazolium chloride test (113). Physical constants and spectral measurements indicated that this component was 3-hydroxybeyer-15-en-2-one, VI.

The third fraction proved to be a complex mixture in which the diosphenol, VII, was the major constituent. Its presence was indicated by the development of an intense brownish-mauve colour on treatment with a neutral ferric chloride solution, and was not further investigated.

2.2. Spirostachic acid or 2,3-Secobeyer-15-en-2,3-dioic acid, VIII.

Repeated crystallisations of the acidic fraction from the counter-current distribution afforded colourless needles shown by various chemical and spectral data to be the seco-diacid, VIII, which has not previously been reported as a natural product.

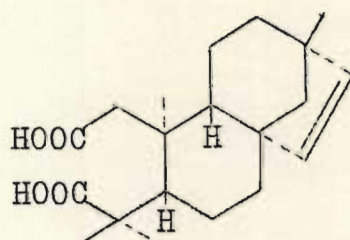

VIII

Elementary analysis established the molecular formula of  $C_{20}H_{30}O_4$ , but the nature of the oxygen functions was not readily determined since colour tests with such reagents as neutral ferric chloride, triphenyltetrazolium chloride and 2,4-dinitrophenylhydrazine proved negative. Under normal conditions for acetylation no acetate was formed, and hence the oxygens could not have been involved in hydroxy groupings. The ready solubility of the compound in alkali and its reprecipitation by acid suggested that the oxygens were involved in carboxy groups. The number of acid groupings was determined by a standard titration of the acid, VIII, with sodium hydroxide, whence it was established that there were two replaceable hydrogens thereby showing VIII to be a dibasic acid.

The infrared spectrum of VIII (Figure 28) provided substantial support for its dicarboxylic nature by the occurrence in the carbonyl region of two bands at 1718 and 1685  $cm^{-1}$  (125). Moderately strong absorptions at 2655 and 2560  $cm^{-1}$  could be ascribed to the O-H stretching vibrations in dimeric acids which have been well investigated (126).

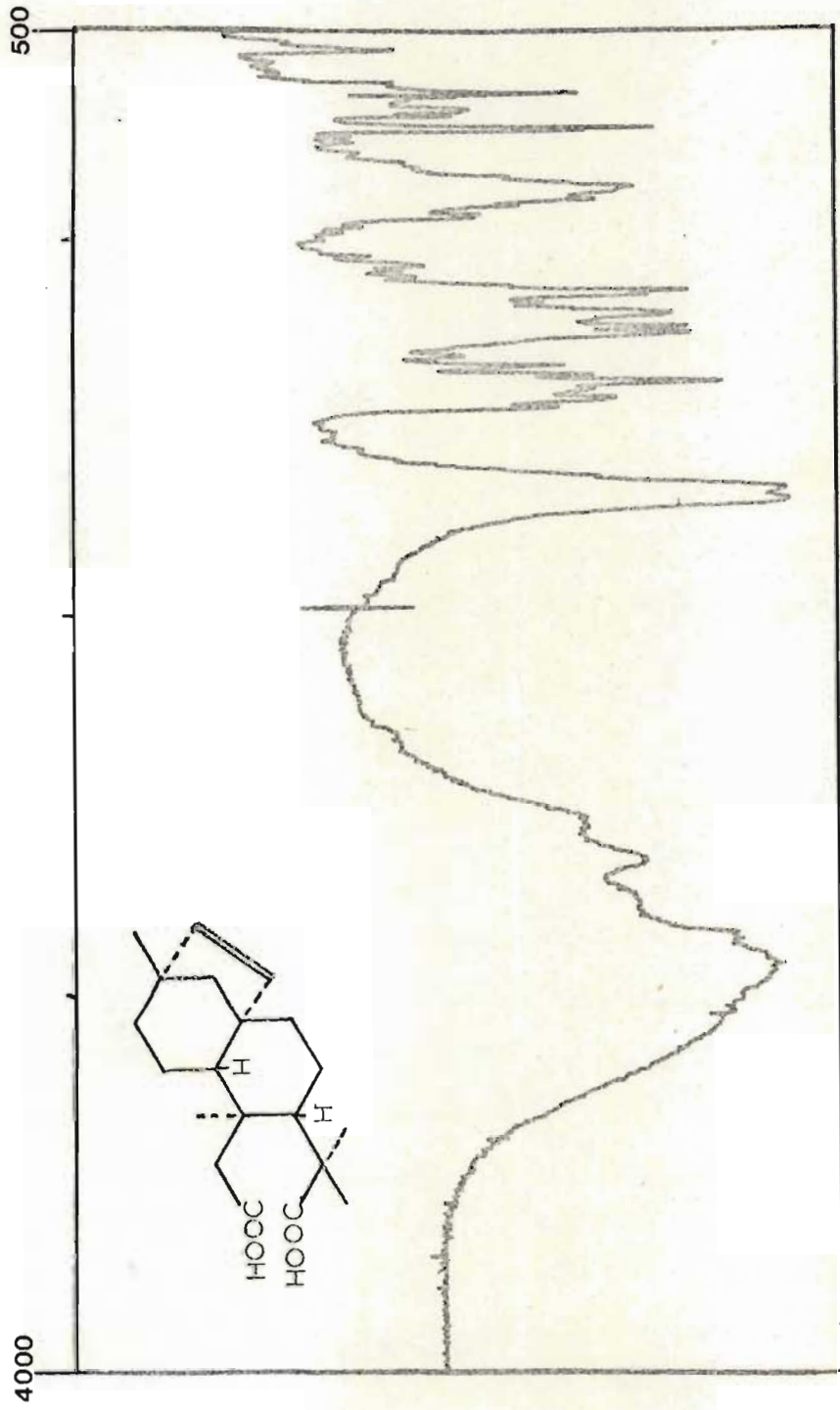

FIGURE 28 IR SPECTRUM OF SPIROSTACHIC ACID



The bands which appeared at 1410, 1280 and 935  $\text{cm}^{-1}$  are characteristic of carboxylic acid dimers and are attributable to the coupled C-O and O-H vibrations and the O-H out-of-plane bending in the dimer (127).

Absorptions occurring at 1385 and 1362  $\text{cm}^{-1}$  signified the presence of the gem-dimethyl groupings (128). The ratio intensity of these bands and the appearance of a further absorption near 1385  $\text{cm}^{-1}$  indicated (129) the presence of an angular methyl group between two six-membered rings i.e. probably at C-10. The similarity of these infrared absorption measurements to the reported (7) values of the compounds previously isolated from Spirostachys implied that the diacid, VIII, was derived from a similar hydrocarbon skeleton.

The tetranitromethane test produced a canary yellow colouration in the acid, thereby indicating some degree of unsaturation, but the ultraviolet absorption spectrum failed to exhibit any characteristic bands above 210 nm., which therefore showed the absence of conjugation in the molecule.

In the infrared spectrum (Figure 28) bands due to the =C-H and C=C stretch vibrations were unfortunately obscured by the intense C-H and C=O absorptions, although an intense band appearing at 746  $\text{cm}^{-1}$  could be attributed to a cis-double bond (7).

The n.m.r. spectrum of the parent acid, VIII, (Figure 29) displayed an ideal AB system consisting of two doublets (130) centred at  $\tau$  4.35 and 4.55 ( $J=8$  Hz) comparable with the equivalent cis-arranged C-15 and C-16 protons

in the five-membered rings of a secobeyerene, LXIII, (73) or in the hydrocarbon hibaene, CVI, (131). The broad singlets at  $\tau$ 7.38 and 7.51 each due to two protons probably arose from the C-1 and C-14 methylene resonances, while the poorly defined triplet at  $\tau$ 7.92 due to two protons could possibly be attributed to the quaternary hydrogens at C-5 and C-9 which are in similar environments.

The four tertiary C-methyl signals for hibaene, CVI, are reported to occur at  $\tau$ 9.03, 9.15, 9.19 and 9.27 (131). In the spectrum of the diacid, CVII, these signals appeared at  $\tau$ 8.76, 8.83, 9.01 and 9.15. Assuming that the latter two signals corresponded with the first two mentioned for hibaene, it seems feasible that those signals which underwent a change in chemical shift viz.  $\tau$ 9.19 to 8.76 and  $\tau$ 9.27 to 8.83 were due to the deshielding effects of the two carboxy groups on the gem-dimethyl substituents at C-4. Thus the singlet at  $\tau$ 9.01 was probably due to the C-13 methyl group within the shielding influence of the nuclear double bond, while that at  $\tau$ 9.15 could be attributed to the C-10 angular methyl substituent.

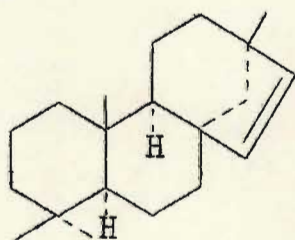

CVI

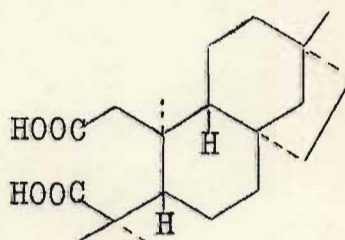

CVII



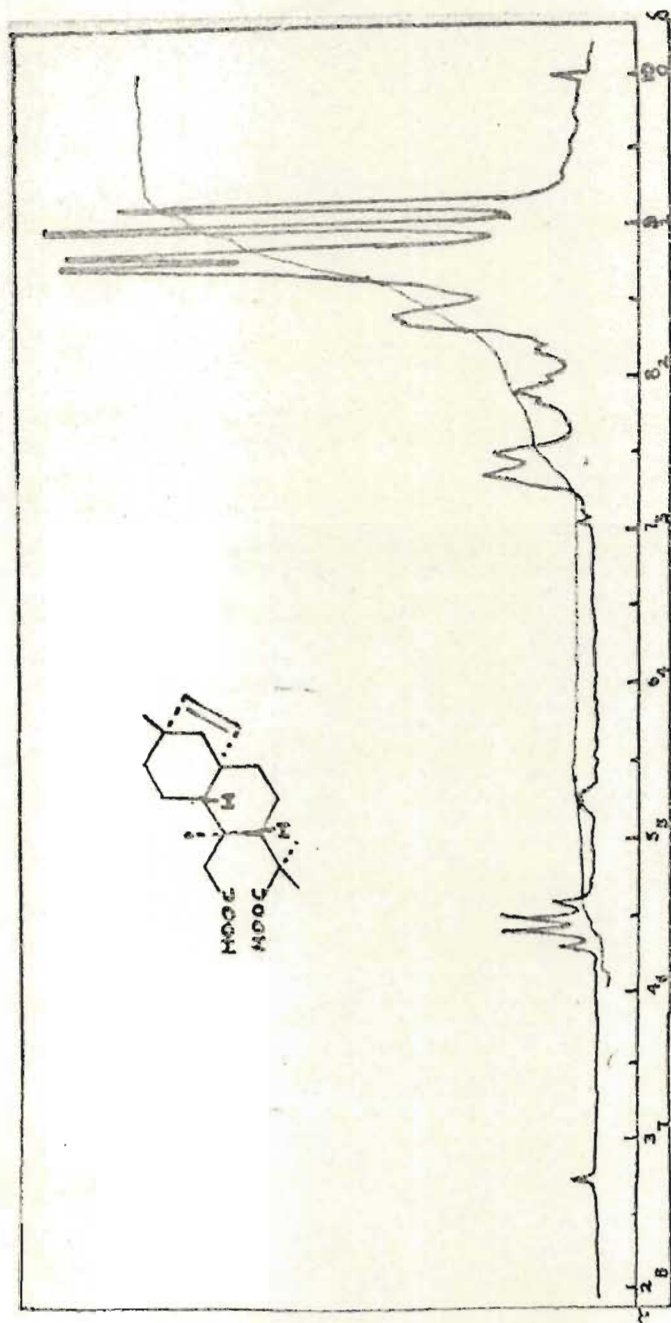

FIGURE 29 NMR SPECTRUM OF SPIROSTACHIC ACID



In order to determine the number of olefinic double bonds present in the diacid, VIII, a quantitative hydrogenation was performed over Adam's catalyst in acetic acid. The absorption of hydrogen was completed over a short period of time during which one mole of hydrogen was absorbed. This formation of the dihydro-derivative, CVII, confirmed the presence of only one double bond in the parent acid, VIII. The infrared spectrum of CVII was very similar to that of VIII except for the disappearance of the band at  $746\text{ cm.}^{-1}$ .

Its n.m.r. spectrum clearly showed the compound to be fully saturated by the absence of any signals in the olefinic region, whilst the remainder of the spectrum appeared to be less resolved due possibly to the change in conformation or ring strain caused by saturation of the D ring.

#### The Methyl Esters of Spirostachic Acid.

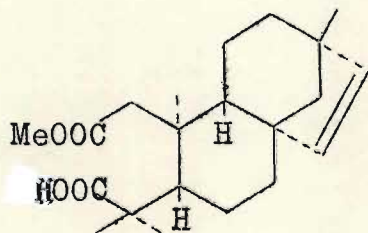

CVIII

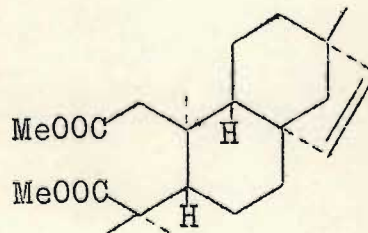

CIX

Attempts to methylate the diacid, VIII, by the Fischer-Speier method for esterification (132) resulted in

the formation of only a monomethyl ester,  $C_{21}H_{32}O_4$ , CVIII. Its infrared spectrum exhibited a band at  $2653\text{ cm.}^{-1}$  attributable to the O-H stretching vibration in a carboxylic acid dimer (125), while an observable effect of this methylation was the separation of the carbonyl stretching absorptions into two bands at  $1740$  and  $1685\text{ cm.}^{-1}$  due to the ester and free acid carbonyls respectively. Furthermore, the characteristic short wavelength ester band occurred at  $1158\text{ cm.}^{-1}$  accompanied by bands between  $1300 - 1000\text{ cm.}^{-1}$ .

Many investigators observed that the rate of formation of the ester, which proceeds by an  $S_N2$  mechanism, depended on the nature of the substituents in the position  $\alpha$ - to the carboxy group rather than steric effects alone (133). The proximity of an electron-donating group was found to inhibit the attack of the reagent in the bond making process, and thus it was deduced that in the ester, CVIII, esterification had occurred at the C-2 rather than the C-3 carboxy group which was adjacent to the electron-donating C-4 gem-dimethyl substituents. A similar case of monomethylation was reported (69) for the diacid, LVII (a), isolated from an Australian Euphorbiaceae. The 17-methyl ester was readily furnished under Fischer-Speier conditions, while the C-19 carboxy grouping remained unchanged.

The dimethyl ester,  $C_{22}H_{34}O_4$ , CIX, was the predominant product on treatment of the diacid, VIII, with diazomethane. A comparison of the fragments in the mass spectra of the acid and its esters confirmed the seco-acid



nature of the parent compound, VIII, and furthermore that the acid groups were located at C-2 and C-3.

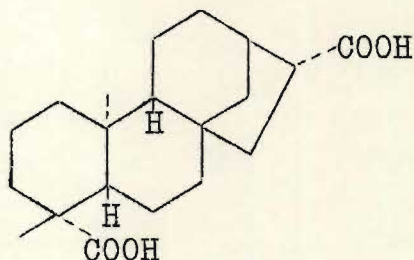

LVII (a)

#### Other Derivatives of Spirostachic Acid.

Reduction of the diacid, VIII, with lithium aluminium hydride produced a mixture of products, which on purification by means of column chromatography, furnished a major constituent whose identity as the diol, CX, was substantiated by the molecular formula,  $C_{20}H_{34}O_2$ . Its infrared spectrum showed that the carboxy groups were no longer present since the absorptions around 2650 and 1700  $cm^{-1}$  disappeared and were replaced instead by a characteristic intense hydroxy hump around 3340  $cm^{-1}$ . In addition to the usual cis double bond peak at 746  $cm^{-1}$  a weak band was detectable at 3052  $cm^{-1}$  due to the =C-H stretch vibrations. An intense band at 1013  $cm^{-1}$  may be tentatively assigned to the C-O stretching vibrations of the hydroxy attachments.

Spirostachic acid, VIII, on treatment with acetic anhydride furnished a crystalline product,  $C_{20}H_{28}O_3$ , deduced to be an anhydride, CXI, from its spectral data. The infrared



spectrum displayed the anhydride carbonyl absorptions at 1796 and 1758  $\text{cm}^{-1}$  together with the usual cis double bond absorption at 746  $\text{cm}^{-1}$  whilst the n.m.r. spectrum was not significantly changed from that of the free acid.

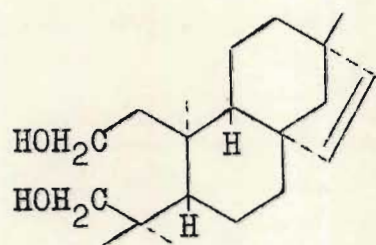

CX

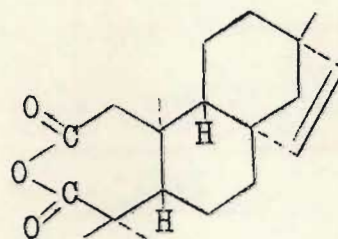

CXI

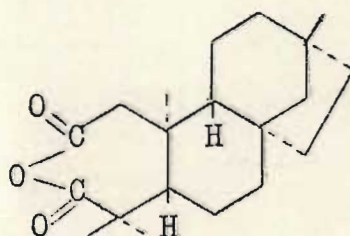

CXII

Similar treatment of dihydrospirostachic acid, CVII, with acetic anhydride afforded a crystalline anhydride,  $\text{C}_{20}\text{H}_{30}\text{O}_3$ , CXII. The physical characteristics of this anhydride were identical with those reported (7) for the anhydride derived from 2,3-secobeyeran-2,3-dioic acid, CVII, which had been synthesised to facilitate the structural elucidation of the Spirostachys constituents. These results served to confirm that dihydrospirostachic acid and 2,3-secobeyeran-2,3-dioic acid were one and the same compound possessing the structure shown in CVII.

Thus it was deduced that the seco-diacid, VIII, differed from 2,3-secobeyeran-2,3-dioic acid, CVII, by only an olefinic double bond and this was shown by infrared and n.m.r. data to be situated at C-15, C-16.

#### The Mass Spectra of Spirostachic Acid and its Derivatives

The mass spectra of spirostachic acid and its dihydro, monomethyl and dimethyl derivatives presented a series of fragmentation patterns which proved most valuable in the assignment of the basic 2,3-secobeyerane skeleton to these compounds.

Because of the well-known fact that esters are more volatile than their corresponding acids, studies were concentrated on spectra of both the mono- and dimethyl esters in relation to the parent acid. Comprehensive surveys have been conducted on a large number of spectra of long chain aliphatic esters in particular (134,135), and their basic patterns of cleavage and rearrangement can be applied to alicyclic esters as well.

The spectrum of spirostachic acid, VIII, (Figure 30) displayed a weak molecular ion peak at  $m/e$  334 whilst in the spectrum of its dihydro derivative, CVII, (Figure 31) the molecular ion peak was absent. However, in both spectra the M-18 fragment appeared and this may have arisen by the loss of the elements of water from the molecular ion to give the anhydride ion as shown on the next page.



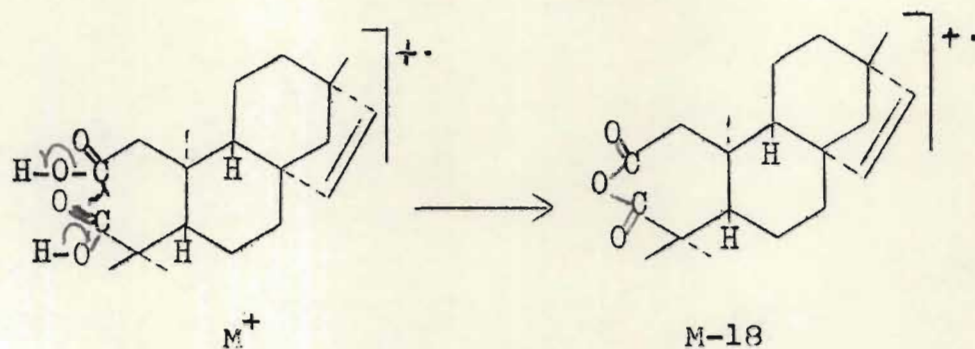

In the spectra of monomethylspirostachate, CVIII, (Figure 32) and dimethylspirostachate, CIX, (Figure 33) the molecular ion peaks appeared at  $m/e$  348 and 362 respectively in low intensities, but  $M-18$  peaks were undetectable. The base peaks in all these spectra occurred at  $m/e$  187 except in the case of dihydrospirostachic acid in which the peak appeared as expected at  $m/e$  189. These fragments probably arose by the mechanisms illustrated in Scheme B in which  $\beta$ -cleavage to either of the carboxyl groups is followed by a McLafferty rearrangement (136). Thus the  $m/e$  187 fragment in the spectrum of the dihydro- compound would be the corresponding ion containing a saturated D ring.

SCHEME B

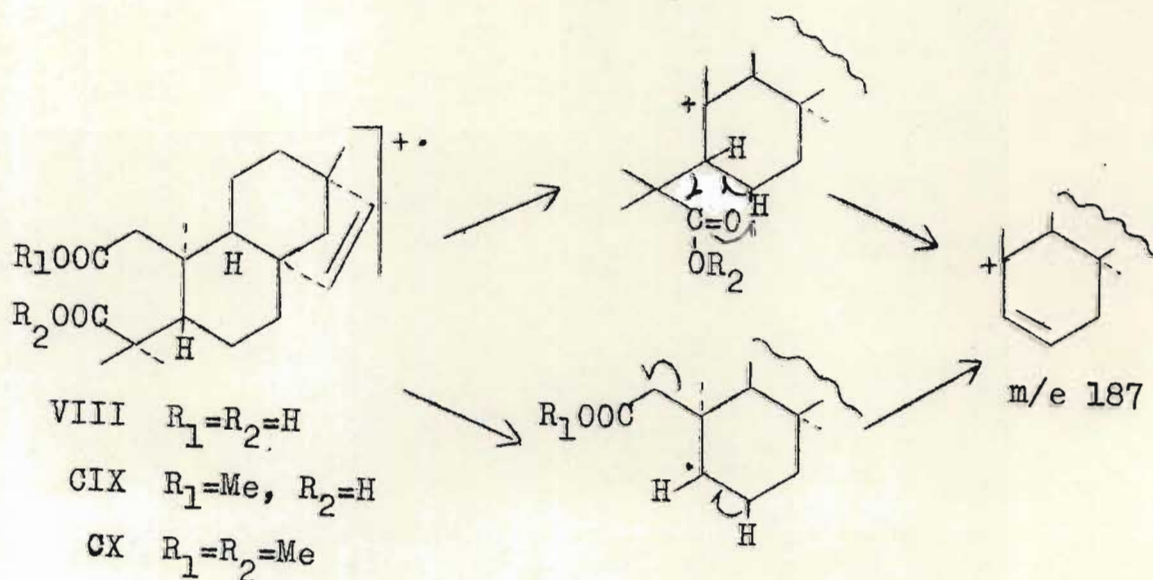



The next peaks of significance for the diacid, VIII, appeared at  $m/e$  275 (42%) and 247 (43%). These ions are shown in Scheme 8 to arise by cleavage of the C-1, C-10 and C-4, C-5 bonds respectively, and have been confirmed by accurate mass measurements which correspond with the formulae  $C_{18}H_{27}O_2$  and  $C_{16}H_{23}O_2$  for the two respective fragments. The analogous peaks for monomethylspirotachate occurred at  $m/e$  275 (38.5%) and 261 (12%) respectively, which confirmed that under Fischer-Speier conditions the C-2 carboxyl group underwent esterification in preference to the C-3 grouping. In the case of dimethylspirotachate the corresponding fragments appeared at  $m/e$  289 (39.5%) and 261 (12.5%) respectively. An accurate mass measurement of the former ion was consistent with the formula  $C_{19}H_{29}O_2$  again due to the loss of the C-1, C-2 moiety ( $H_2\dot{C}-CO_2Me$ ) from the molecular ion. Similarly the formula  $C_{17}H_{25}O_2$  was determined for the latter ion, which indicated the loss of the C-3, C-4 moiety ( $Me_2\dot{C}-CO_2Me$ ) from the parent ion.

Prominent peaks observed at  $m/e$  274 (30.5%) and 246 (41%) in the spectrum of the parent acid could again be explained by McLafferty rearrangements.

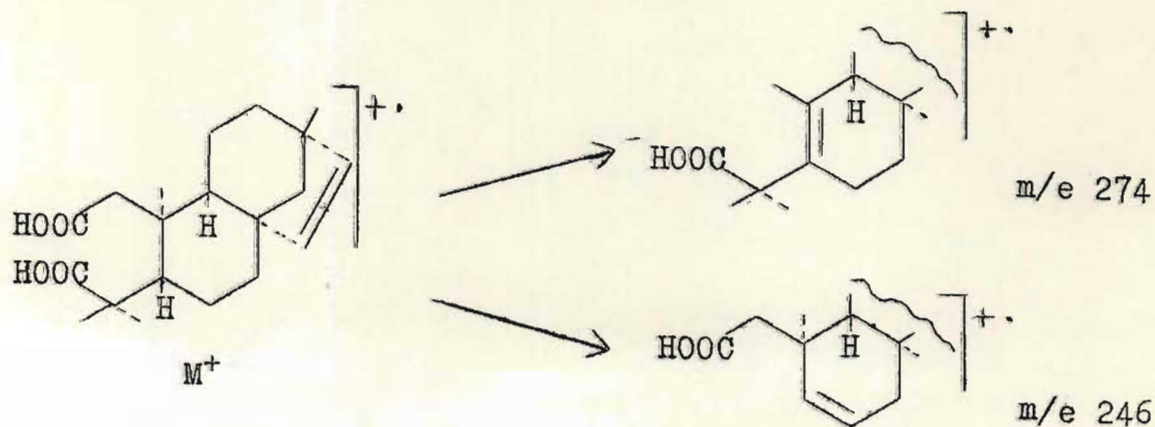

In the spectrum of the monomethyl compound the corresponding ions were detected at  $m/e$  274 (12%) and  $m/e$  260 (9%), whilst in the diester spectrum they were present at  $m/e$  288 (7%) and 260 (7%), but in lower abundance.

A peak at  $m/e$  188 (17%) in the spectra of all the unsaturated compounds may be explained by the ion arising from the simultaneous cleavages of the bonds  $\beta$ - to the carbonyl function as shown below.

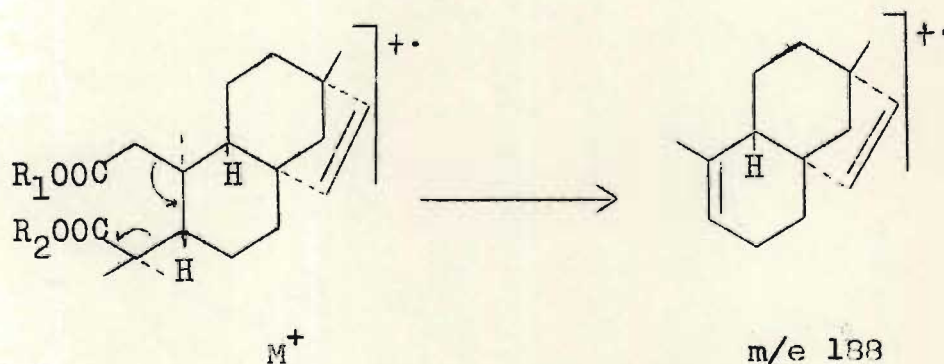

Hydrogenation of the parent acid, VIII, caused an increase of two a.m.u. to this ion which appeared at  $m/e$  190.

Another significant ion common to the unsaturated series occurred at  $m/e$  159, but moved to  $m/e$  161 on hydrogenation, thereby indicating that the fragment contained the D ring. A metastable peak at  $m/e$  135.5 signified that this ion arose from the fragment at  $m/e$  187. The mechanism of this fragmentation probably involves a more complex rearrangement than usual and the following pattern is suggested.



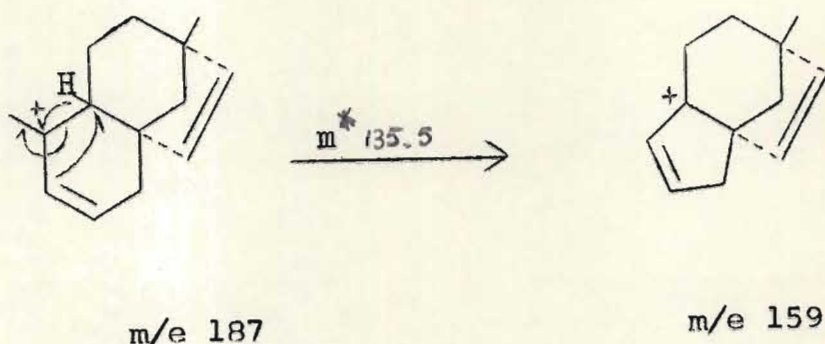

In the upper regions of the spectra less prominent peaks were observed. These were mainly due to various combinations of bond cleavages  $\alpha$ -to the carbonyl functions. The spectrum of spirostachic acid, VIII, displayed a M-45 fragment at  $m/e$  289 which resulted from the loss of  $-COOH$  from the C-2 position. Thus the corresponding fragment M-(45+14) for the monomethyl ester occurred at  $m/e$  289, and at  $m/e$  303 for the dimethyl ester.

The M-46 fragments found in the spectra of the acids, VIII and CVII, and monomethylspirostachate, CVIII, all probably arose by loss of the elements of formic acid from either of the acid groups, and these occurred at  $m/e$  288, 290 and 302 respectively.

Further fragmentation patterns for some of the less significant peaks are illustrated in Scheme 9, whilst the majority of the low mass ions being "remaining portions" of the major fragments will not be discussed again. The overall picture gained from these fragmentations serves to substantiate the structure assigned to spirostachic acid, VIII.



## SCHEME 9

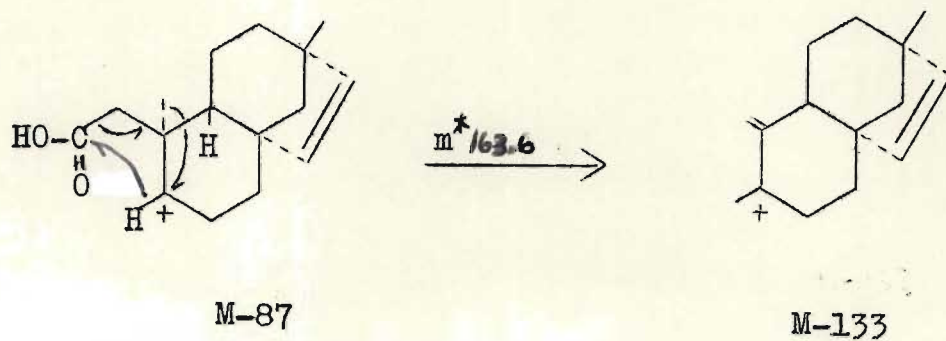
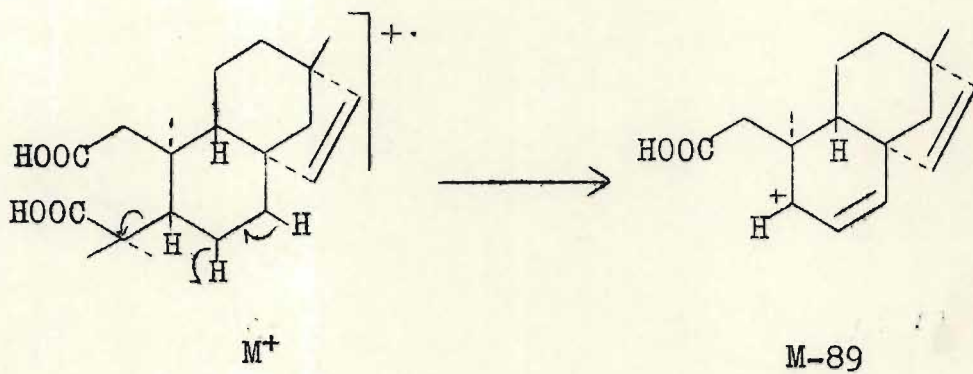
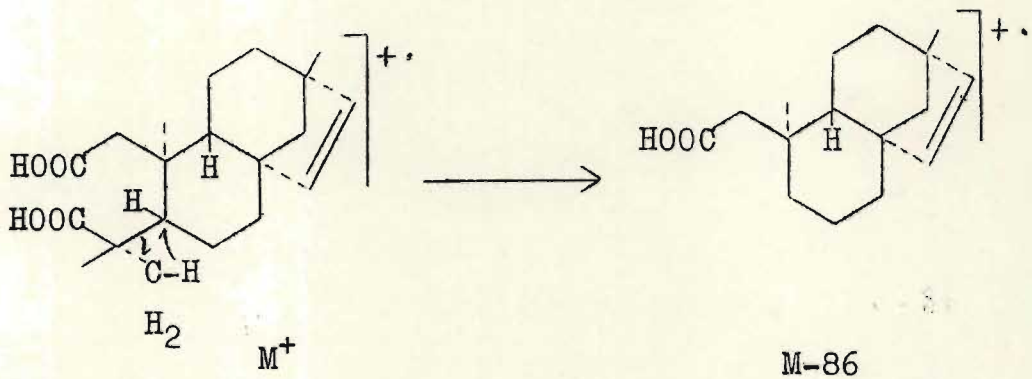
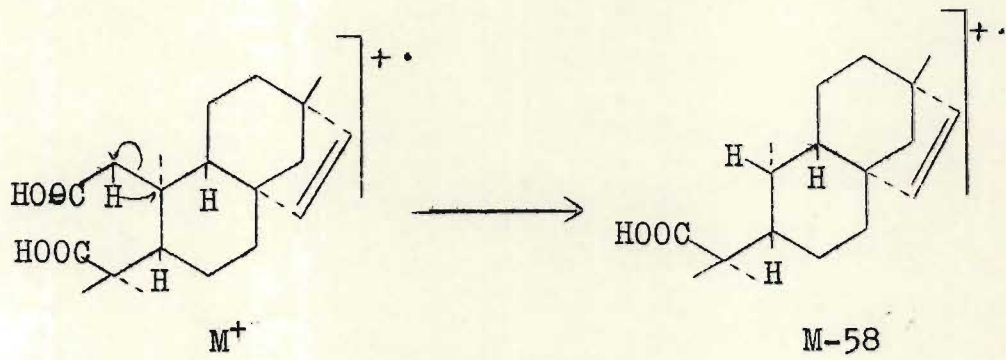

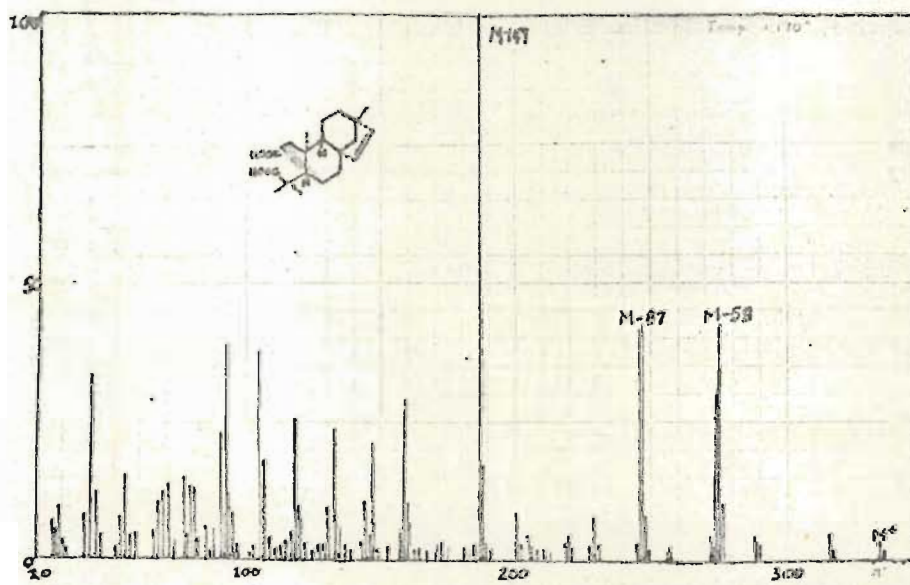

FIGURE 30 MASS SPECTRUM OF SPIROSTACHIC ACID

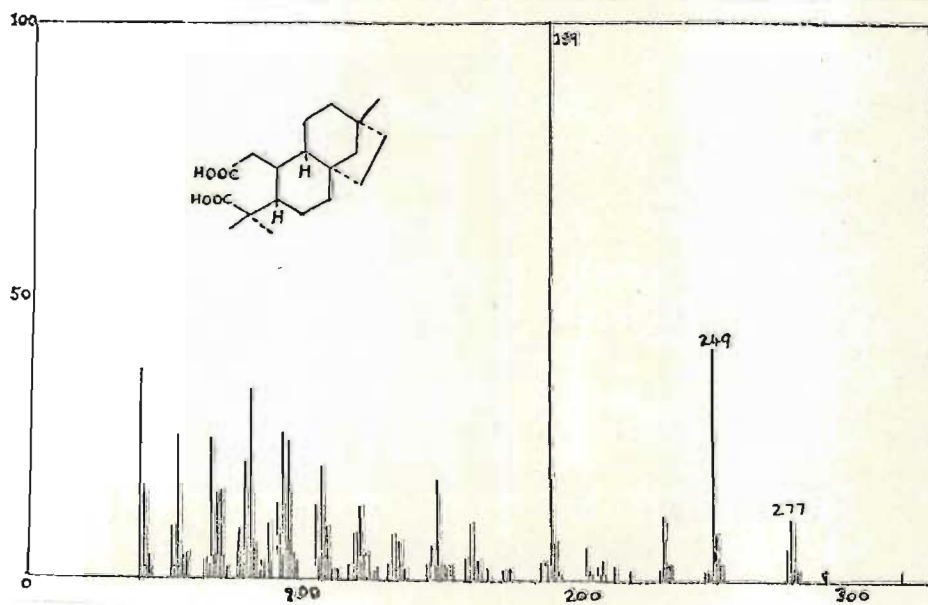

FIGURE 31 MASS SPECTRUM OF DIHYDROPIROSTACHIC ACID

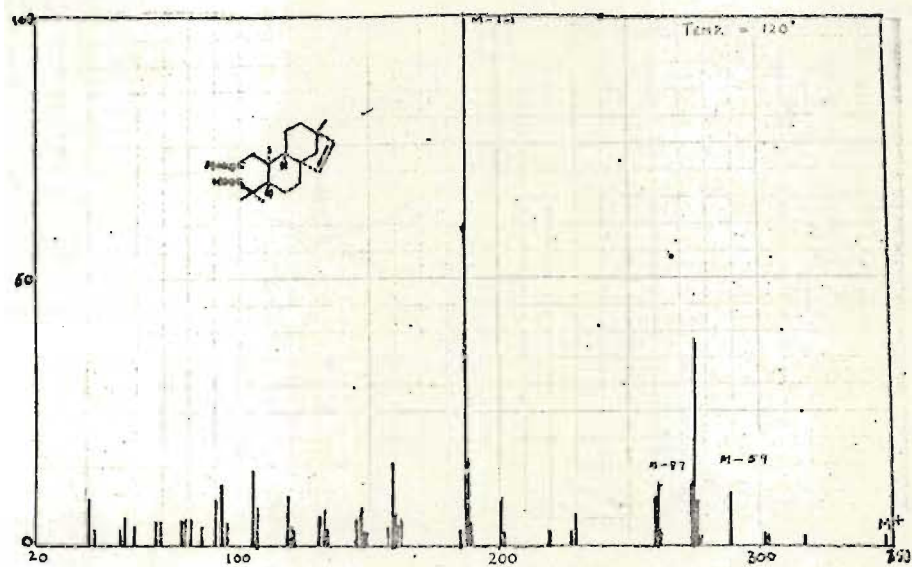

FIGURE 32 MASS SPECTRUM OF MONOMETHYLSPIROSTACHATE

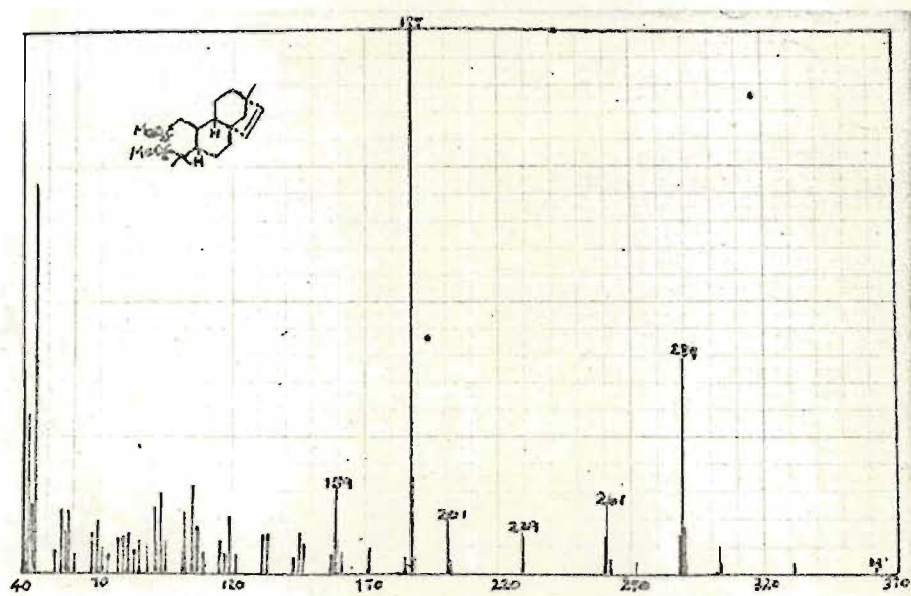
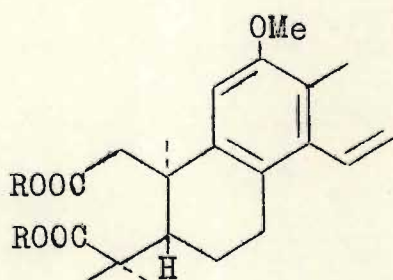

FIGURE 33 MASS SPECTRUM OF DIMETHYLSPIROSTACHATE



The mass spectral fragmentations of the seco-di-acids and their esters have thus proved to be a powerful tool in determining the positions of the carboxylic acid groups. This method may be extended to the determination of the position of olefinic double bonds or the location of vicinal hydroxy groups which may be readily converted into seco-acids. These observations were successfully applied (1,3) in the structure determination of cleistanthol, IV, which was converted to the seco-acid, CXIII (a), and its dimethyl ester, CXIII (b). By the comparison of the mass spectra of these compounds with those of the spirostachic acid derivatives it was possible to confirm that alcoholic hydroxy groups were located at C-2 and C-3.



CXIII (a) R=H  
 (b) R=Me

### Discussion

The co-occurrence of the ketone, V, the ketol, VI, the diosphenol, VII, and the acid, VIII, in Spirostachys africana presents another interesting biogenetic sequence in which the oxidation state of ring A increases from the ketone, V, through to the seco-diacid, VIII, as shown.

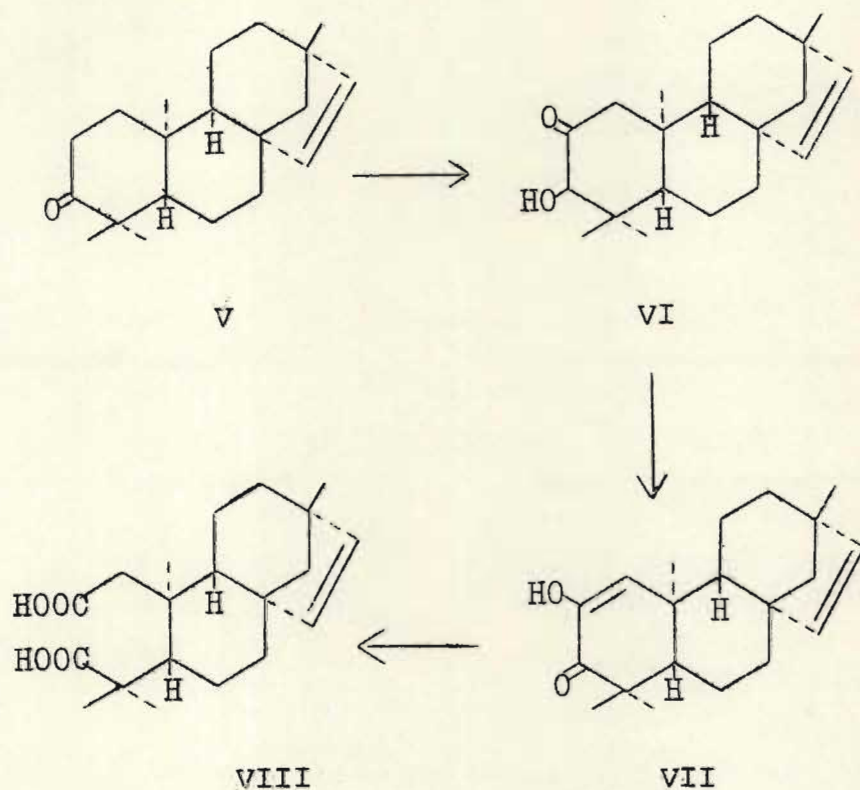

In a number of Western Australian Euphorbiaceae the co-occurrence of diterpenes possessing both kaurene and beyerene (stachene) skeletons has been reported (65,67,73, 74), with the former usually featuring more prominently. In contrast no compounds possessing the kaurene skeleton were identified during the present investigation, although this by no means precludes their presence entirely.

## CONCLUSION

From the classical concepts of biosynthesis the beyerene (stachene) class of tetracyclic diterpenes is considered to arise by a certain mode of collapse of the carbonium ion resulting from the cyclisation of ent-pimaradiene (Figure 2). As yet no such precursors have been detected in Spirostachys africana in marked distinction to the presence of the ent-isopimara-diene precursors in Cleistanthus schlechteri. Furthermore, from Beyeria brevifolia, a sec-ent-pimaradiene, XLIV, (58) has been reported to occur together with three kaurenoid diterpenes (67), thereby probably implying the former to be the precursor of the latter compounds.

A further point of interest worthy of speculation is the fact that in some species of Euphorbiaceae triterpenoids have been isolated to the exclusion of any diterpenoid constituents and vice versa. From the chemotaxonomic point of view there appears to be no correlation between this phenomenon and the division into sub-families of the Euphorbiaceae (137). In fact Croton oblongifolius L (59) contains pimaradienes, while many Euphorbia (138) which belong to the same sub-family, Crotonoideae, have yielded mainly triterpenes. Even greater versatility was shown by the co-occurrence of diterpenes and triterpenes reported in Beyeria leschenaultii (68). However, a much more detailed survey is needed before a reasonable hypothesis for chemotaxonomic divisions can be proposed.



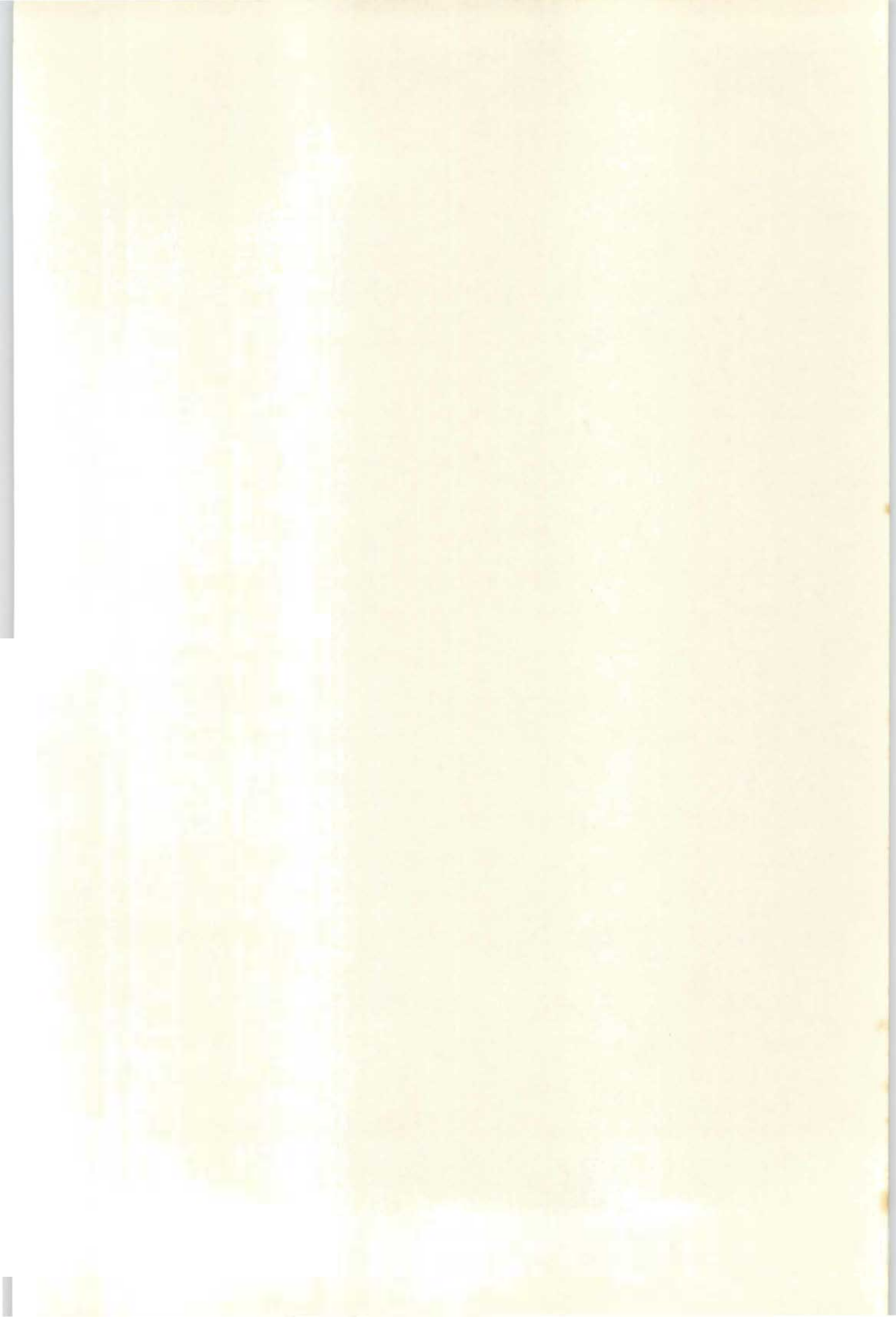

EXPERIMENTAL

The following generalisations apply throughout the experimental section, unless otherwise specified. Melting points were determined on a Kofler micro hot-stage and are uncorrected. Optical rotations of solutions in chloroform were measured at room temperature with a Bellingham and Stanley No. 390817 polarimeter. Infrared spectra of samples in potassium bromide discs were recorded on a Perkin-Elmer model 521 spectrophotometer. Ultraviolet absorption spectra of approximately  $10^{-3}$ M solutions in 95% ethanol were recorded with a Beckmann DB UV/visible recording spectrophotometer; logs in parentheses follows  $\lambda_{\text{max.}}$ . Mass spectra were obtained with an A.E.I. MS 9 double focussing mass spectrometer.  $^1\text{H}$  N.m.r. spectra were measured on Varian A-60 and HA-100 instruments using deuteriochloroform as solvent and tetramethylsilane as internal reference. Optical rotatory dispersion curves of methanolic solutions were recorded on a Jasco ORD/UV-5 instrument. In cases where elementary analyses could not be determined due to lack of material, accurate mass measurements were obtained. The light petroleum used had a boiling range of 56-60°. The solvent employed in crystallisations was aqueous methanol.

### Chromatography

Glass plates for thin layer chromatography were coated to a thickness of 250 $\mu$  with Merck silica gel and activated for thirty minutes prior to use. The solvent systems most commonly used were mixtures of benzene-light petroleum (1:1) and ethanol in varying amounts (0-10%) depending on the polarity of the compounds to be separated.

Two spray reagents were utilised in the detection of the components on thin layer chromatograms. These were 1) a 20% solution of antimony pentachloride in chloroform 2) a 5% solution of p-anisaldehyde in 5% ethanolic sulphuric acid. The plates were sprayed with one of these reagents and heated to 100<sup>o</sup> for 5-10 minutes to allow the full development of colours.

In routine column chromatography basic aluminium oxide was mainly used. This was found to be more successful in separating the ketol, II, and the diol, III, in better yields, while silica gel of particle size between 0.05 and 0.2 mm. yielded more of the alcohol, I. The solvent systems employed for eluting ranged from light petroleum to mixtures of light petroleum-benzene (1:1) and gradually increasing amounts of ethanol (0-5%). It has been established that with the use of these eluants migration rates of the components are chiefly dependent on the ethanol concentration (139).



## Colour Reactions

### (a) Tetranitromethane

The sample (1 mg.) was treated with tetranitromethane (1 drop) on a spot plate, and any colour produced within five minutes was noted. Varying shades of yellow were produced by compounds containing olefinic double bonds (81), whilst saturated compounds remained unchanged.

### (b) Zimmermann Test

The sample (100 mg.) was dissolved in 2N potassium hydroxide in absolute ethanol (1 ml.) and 1% m-dinitrobenzene in absolute ethanol (1 ml.) and set aside for 10 min. On dilution to 10 ml. with absolute ethanol the fading of a violet colour indicated that the sample was a C-3 ketone (98).

### (c) Triphenyltetrazolium chloride

The sample (2 mg.) dissolved in absolute ethanol (1 ml.) was treated with a solution of triphenyltetrazolium chloride (TTC) in absolute ethanol (1%, 1 ml.), followed by aqueous sodium hydroxide (10%, 1 drop). The appearance of a red colour or a red precipitate due to the formation of the triphenylformazan indicated the presence of an  $\alpha$ -ketol or any other easily oxidised structure (113).

PART 1    CLEISTANTHUS SCHLECHTERISource and Extraction of the Heartwood Diterpenes

The heartwood was obtained from three trees of Cleistanthus schlechteri var. schlechteri, Family Euphorbiaceae, collected in the coastal region of Zululand, Natal. Botanical specimens of each were deposited at the Natal Herbarium under the numbers NH 53049, 57826 and 60870. The light petroleum extracts of the heartwood from the three trees were shown to be identical by thin layer chromatography.

The milled, air-dried heartwood (6.68 Kg.) was soaked for 12 hr. at room temperature in light petroleum (8 l.), which on evaporation yielded an orange syrup (102 g.). Further exhaustive extraction of the wood with refluxing light petroleum (48 hr.) caused the separation of crude cleistanthol, IV, (104 g., 1.55%) and a dark orange syrup (95 g.) identical in composition to the cold extract.

Portions of the cold extract (15 g.) dissolved in light petroleum-chloroform (5:1, 75 ml.) were applied to columns of basic aluminium oxide (300 g.). Elution with light petroleum gave a mixture of fatty products (2.1 g.), while further elution with a mixture of benzene-light petroleum (1:1) afforded crystals of 3 $\alpha$ -hydroxy-ent-isopimara-8(14),15-diene, I, (0.2 g.). Repeated crystallisations gave colourless needles, m.p. 126-127 $^{\circ}$ ,  $[\alpha]_D^{25} +12.5^{\circ}$  (c 1), m/e 288 (M $^{+}$ ).



(Found: C, 83.1; H, 11.3.  $C_{20}H_{32}O$  requires C, 83.3; 11.2%)

$\nu_{\max.}$  3325 br (O-H), 3080 ( $C=CH_2$ ) and 1631 ( $C=C$ )  $cm^{-1}$

$\tau$  4.19 (1H, q, C-15 H,  $J_{\text{obs.}}$  10 and 18 Hz), 4.75 (1H, s, C-14 H), 5.10 (2H, m, 2xC-16 H), 6.73 (1H, m, C-3 H), 8.95, 8.99, 9.17 and 9.19 (4x3H, 4xs, 4xMe).

(Reported for isopimara-8(14),15-dien-3 $\beta$ -ol, LXXXV (c): m.p. 126.5-127.5 $^{\circ}$ ,  $[\alpha]_D -19.5^{\circ}$ (100); the mass spectrum (103) and i.r. spectrum were identical to those given by I).

The addition of ethanol to the eluting mixture (benzene-light petroleum-ethanol; 1:1:0.01) yielded crystals of 3 $\alpha$ -hydroxy-ent-isopimara-8(14),15-dien-12-one, II, (1.8 g.). Recrystallisation from light petroleum-ethanol gave large colourless prisms, m.p. 157-158 $^{\circ}$ ,  $[\alpha]_D +290^{\circ}$ (c 1), m/e 302 ( $M^+$ ).

(Found: C, 79.3; H, 10.0.  $C_{20}H_{30}O_2$  requires C, 79.4; H, 10.0%)

$\nu_{\max.}$  3547 s (O-H), 3085 ( $=CH_2$ ), 1696 ( $C=O$ ) and 1628 ( $C=C$ )  $cm^{-1}$

$\lambda_{\max.}$  300 (2.28) nm.

$\tau$  4.25 (1H, q, C-15 H,  $J_{\text{obs.}}$  10 and 18 Hz), 4.76 (1H, s, C-14 H), 4.89 (2H, m, 2xC-16 H), 6.76 (1H, m, C-3 H), 8.78, 8.87, 9.20 and 9.29 (4x3H, 4xs, 4xMe).



A further increase in the ethanol content of the eluant above (1:1:0.04) furnished crystals of 3 $\alpha$ ,12 $\alpha$ -di-hydroxy-ent-isopimara-8(14),15-diene, III, (0.6 g.). On recrystallisation colourless, long spars were obtained, m.p. 161-162 $^{\circ}$ ,  $[\alpha]_D^{28} +28^{\circ}$  (c 1), m/e 304 ( $M^+$ ).

(Found: C, 78.7; H, 10.8.  $C_{20}H_{32}O_2$  requires C, 78.9; H, 10.6%)

$\nu_{max.}$  3290 br (O-H) and 1635 (C=C)  $cm^{-1}$

$\tau$  4.22 (1H, q, C-15 H,  $J_{obs.}$  10 and 18 Hz), 4.93 (3H, m, C-14 H and 2xC-16 H), 6.45 (1H, m, C-12 H), 6.75 (1H, m, C-3 H), 8.93, 8.98, 9.16 and 9.16 (4x3H, 4xs, 4xMe).

Continued elution with a more polar solvent system (5-10% ethanol) produced a brown gum (5 g.) containing traces of cleistanthol, IV, amongst a mixture of many other constituents.

#### Acetylation Products

3 $\alpha$ -Hydroxy-ent-isopimara-8(14),15-diene, I, (0.1 g.) dissolved in a mixture of dry pyridine (5 ml.) and acetic anhydride (0.5 ml.) was set aside overnight, then poured into ice-water with stirring. The crude product was filtered and dried, and on crystallisation yielded colourless needles of 3 $\alpha$ -acetoxy-ent-isopimara-8(14),15-diene, LXXVII, (0.1 g.), m.p. 104-105 $^{\circ}$ ,  $[\alpha]_D^{-7} -7^{\circ}$  (c 1), m/e 330 ( $M^+$ ).

(Found: C, 79.9; H, 10.5.  $C_{22}H_{34}O_2$  requires C, 80.0, H, 10.4%)

$\nu_{\max}$ . 3080 s ( $C=CH_2$ ), 1712 (acetate  $C=O$ ), 1630 ( $C=C$ ) and 1240 (ester  $C-O$ )  $cm^{-1}$

(Reported for  $3\beta$ -acetoxyisopimara-8(14),15-diene, LXXXV (d): m.p. 102-104.5°,  $[\alpha]_D^{20} +4^\circ$  (100) ).

$3\alpha$ -Hydroxy-ent-isopimara-8(14),15-dien-12-one, II, (0.2 g.) was acetylated by the method described above to give, on crystallisation, colourless prisms of  $3\alpha$ -acetoxy-ent-isopimara-8(14),15-dien-12-one, XCI, (0.19 g.), m.p. 127-128°,  $[\alpha]_D^{20} +210.5^\circ$  (c 1), m/e 344 ( $M^+$ ).

(Found: C, 76.5; H, 9.4.  $C_{22}H_{32}O_3$  requires C, 76.7; H, 9.4%)

$\nu_{\max}$ . 3078 ( $C=CH_2$ ), 1723 (acetate  $C=O$ ), 1700 (C-12 carbonyl) and 1243 (ester  $C-O$ )  $cm^{-1}$

$\tau$  4.25 (1H, q, C-15 H,  $J_{\text{obs}}$  10 and 18 Hz), 4.74 (1H, s, C-14 H), 4.89 (2H, m, C-16 H), 5.50 (1H, m, C-3 H), 7.96 (3H, s,  $CH_3C=O$ ), 8.78, 9.10, 9.14 and 9.28 (4x3H, 4xs, 4xMe).

$3\alpha$ ;12 $\alpha$ -Dihydroxy-ent-isopimara-8(14),15-diene, III, (0.1 g.) was acetylated as described above and yielded, after crystallisation, colourless needles of  $3\alpha$ ;12 $\alpha$ -di-acetoxy-ent-isopimara-8(14),15-diene, XCIX, (0.1 g.), m.p.

117°,  $[\alpha]_D^{+33}$  (c 1), m/e 388 ( $M^+$ ).

(Found: C, 73.9; H, 9.4.  $C_{24}H_{36}O_4$  requires C, 74.2; H, 9.3%)

$\nu_{max}$ . 3095 ( $C=CH_2$ ), 1733 and 1721 (C-12 and C-3 acetate C=O respectively) and 1235 (ester C-O)  $cm^{-1}$

$\tau$  4.39 (1H, q, C-15 H,  $J_{obs}$ , 10 and 18 Hz), 4.85 (1H, s, C-14 H), 5.05 (2H, m, 2xC-16 H), 5.19 (1H, overlapped, C-12 H) and 5.48 (1H, m, C-3 H).

#### Oxime of the Ketol, II

3 $\alpha$ -Hydroxy-ent-isopimara-8(14),15-dien-12-one, II, (0.1 g.) and hydroxylamine hydrochloride (0.2 g.) were dissolved in a mixture of pyridine (10 ml.) and ethanol (10 ml.), then set aside for 24 hr. Dilution with ice-water caused the precipitation of the oxime which was crystallised to give colourless cubes, m.p. 167-168°,  $[\alpha]_D^{+163}$  (c 1), m/e 317 ( $M^+$ ).

(Found:  $M^+$ , m/e 317.235202.  $C_{20}H_{31}NO_2$  requires  $M^+$ , m/e 317.235466).

#### Catalytic Reductions

3 $\alpha$ -Hydroxy-ent-isopimara-8(14),15-diene, I, (0.1 g.) dissolved in ethanol (10 ml.) was stirred with hydrogen in the presence of palladium-charcoal catalyst (30 mg., 30%) until the uptake of hydrogen ceased (30 min.). During this



period 8 ml. of hydrogen was absorbed at N.T.P. (theoretical for 1 mole, 7.6 ml.). Crystallisation of the product yielded colourless, silky needles of 3 $\alpha$ -hydroxy-ent-isopimar-8(14)-ene, LXXVIII (a), (95 mg.), m.p. 132-133 $^{\circ}$ ,  $[\alpha]_D -23.2^{\circ}$  (c 2), m/e 290 ( $M^+$ ).

(Found: C, 82.7; H, 11.8.  $C_{20}H_{34}O$  requires C, 82.7; H, 11.8%)

$\nu_{max}$ . 3320 (O-H) and 1631 w (C=C)  $cm^{-1}$

(Reported for isopimar-8(14)-en-3 $\beta$ -ol, LXXXVI: m.p. 132-132.5 $^{\circ}$ ,  $[\alpha]_D +25.5^{\circ}$ , (100) ).

3 $\alpha$ -Hydroxy-ent-isopimara-8(14),15-diene, I, (0.2 g.) in glacial acetic acid (20 ml.) was hydrogenated under high pressure (1400 lb./sq. in.) in the presence of platinum oxide catalyst (50 mg.) for 24 hr. (fresh catalyst being added every 8 hr.). Hydrogenation was shown to be complete by a negative tetranitromethane test. Crystallisation of the crude product gave colourless needles of 3 $\alpha$ -hydroxy-ent-isopimarane, LXXIX, (0.12 g.), m.p. 135 $^{\circ}$ ,  $[\alpha]_D -46.8^{\circ}$  (c 1), m/e 292 ( $M^+$ ).

(Found: C, 82.3; H, 12.5.  $C_{20}H_{36}O$  requires C, 82.1; H, 12.4%)

(Reported for isopimaran-3 $\beta$ -ol, LXXXVII: m.p. 134-135.5 $^{\circ}$ ,  $[\alpha]_D +21.8^{\circ}$ , (100) ).

3 $\alpha$ -Acetoxy-ent-isopimara-8(14),15-diene, LXXVII,

(0.1 g.) was hydrogenated over palladium-carbon catalyst in ethanol (10 ml.) as described above to afford colourless needles of 3 $\alpha$ -acetoxy-ent-isopimar-8(14)-ene, LXXVIII (b), (90 mg.), m.p. 117-118 $^{\circ}$ ,  $[\alpha]_D -47^{\circ}$  (c 1), m/e 332 ( $M^+$ ).

(Found: C, 79.5; H, 11.0.  $C_{22}H_{36}O_2$  requires C, 79.5; H, 10.9%).

3 $\alpha$ -Hydroxy-ent-isopimara-8(14),15-dien-12-one, II, (0.2 g.) in ethanol (20 ml.) over palladium-carbon (50 mg., 30%) absorbed 14.1 ml. of hydrogen at N.T.P. (theoretical for 1 mole, 12.8 ml.). Crystallisation of the product gave colourless needles of 3 $\alpha$ -hydroxy-ent-isopimar-8(14)-en-12-one, XCIII (a), (0.18 g.), m.p. 114-115 $^{\circ}$ ,  $[\alpha]_D +76^{\circ}$  (c 1), m/e 304 ( $M^+$ ).

(Found: C, 78.6; H, 10.6.  $C_{20}H_{32}O_2$  requires C, 78.9; H, 10.6%)

$\nu_{\max.}$  3542 (O-H), 1695 (C=O) and 1655 (C=C)  $cm^{-1}$

$\lambda_{\max.}$  292 (1.75) nm.

$\tau$  4.70 (1H, s, C-14 H) and 6.72 (1H, m, C-3 H).

3 $\alpha$ -Acetoxy-ent-isopimara-8(14),15-dien-12-one, XCI, was hydrogenated in ethanol over palladium-carbon as described above to give colourless needles of 3 $\alpha$ -acetoxy-ent-isopimar-8(14)-en-12-one, XCIII (b), m.p. 108-109 $^{\circ}$ ,  $[\alpha]_D +52^{\circ}$  (c 1), m/e 346 ( $M^+$ ).

(Found: C, 76.2; H, 9.9.  $C_{22}H_{34}O_3$  requires C, 76.3; H, 9.9%)

$\nu_{\max}$ . 1725 (acetate C=O), 1700 (C-12 C=O) and 1242 (ester C-O)  $cm^{-1}$

$\tau$  4.76 (1H, s, C-14 H) and 5.50 (1H, m, C-3 H).

This compound was also obtained by acetylation of 3 $\alpha$ -hydroxy-ent-isopimar-8(14)-en-12-one, XCIII (a) as previously described.

3 $\alpha$ -Acetoxy-ent-isopimara-8(14),15-dien-12-one, XCI, on hydrogenation over a platinum oxide catalyst in glacial acetic acid for 24 hr. (with the addition of fresh catalyst every 8 hr.) yielded crude 3 $\alpha$ -acetoxy-ent-isopimaran-12-ol, XCV. Crystallisation of the product resulted in colourless needles, m.p. 133-134 $^{\circ}$ , m/e 350 ( $M^+$ ).

(Found: C, 75.3; H, 10.9.  $C_{22}H_{38}O_3$  requires C, 75.4; H, 10.9%).

3 $\alpha$ ,12 $\alpha$ -Dihydroxy-ent-isopimara-8(14),15-diene, III, (0.1 g.) was hydrogenated over palladium-carbon in ethanol as described above to give, on crystallisation, colourless needles of 3 $\alpha$ ,12 $\alpha$ -dihydroxy-ent-isopimar-8(14)-ene, C (a), (80 mg.), m.p. 172-173 $^{\circ}$ ,  $[\alpha]_D -31^{\circ}$  (c 1), m/e 306 ( $M^+$ ).



(Found: C, 74.6; H, 11.6.  $C_{20}H_{34}O_2 \cdot CH_3OH$  requires C, 74.5; H, 11.6%).

$\nu_{\max.}$  3300 br (O-H)  $cm^{-1}$

$\tau$  4.88 (1H, s, C-14 H) and 6.53 (2H, m, C-3 and C-12 H).

3 $\alpha$ ,12 $\alpha$ -Diacetoxy-ent-isopimara-8(14),15-diene, XCIX, (0.1 g.) when hydrogenated over palladium-carbon in ethanol yielded colourless, long needles of 3 $\alpha$ ,12 $\alpha$ -diacetoxy-ent-isopimar-8(14)-ene, C (b), (90 mg.), m.p. 132-133 $^{\circ}$ ,  $[\alpha]_D -5.8^{\circ}$  (c 1), m/e 390 ( $M^+$ ).

(Found: C, 73.9; H, 9.9.  $C_{24}H_{38}O_4$  requires C, 73.8; H, 9.8%)

$\nu_{\max.}$  1725 (acetate C=O) and 1238 (ester C-O)  $cm^{-1}$

$\tau$  4.89 (1H, s, C-14 H), 5.19 (1H, q, C-12 H,  $J_{\text{obs.}}$  5 and 11 Hz) and 5.49 (1H, m, C-3 H).

This product was also obtained by acetylation of 3 $\alpha$ ,12 $\alpha$ -dihydroxy-ent-isopimar-8(14)-ene, C (a), by the method previously described.

3 $\alpha$ ,12 $\alpha$ -Dihydroxy-ent-isopimara-8(14),15-diene, III, (0.1 g.) was hydrogenated over platinum oxide catalyst in glacial acetic acid for 24 hr. (fresh catalyst being added every 8 hr.) to give, on crystallisation, colourless

needles of  $3\alpha,12\alpha$ -dihydroxy-ent-isopimarane, CI, (90 mg.),  
m.p.  $164-165^\circ$ ,  $[\alpha]_D -6^\circ$  (c 1), m/e 308 ( $M^+$ ).

(Found: C, 74.1; H, 11.6.  $C_{20}H_{36}O_2 \cdot CH_3OH$  requires C, 74.1;  
H, 11.8%)

$\nu_{\max}$ . 3380 br (O-H)  $cm^{-1}$

$\tau$  6.73 (2H, m, C-3 and C-12 H).

#### Oxidation Products

$3\alpha$ -Hydroxy-ent-isopimara-8(14),15-diene, I, (0.1 g.)  
dissolved in acetone (5 ml.), freshly-distilled over  
potassium permanganate, was treated dropwise with Jones  
reagent (97) until the reaction mixture remained orange-  
brown. The mixture was set aside at  $5^\circ$  for 1 hr. after  
which the addition of ice-water induced the deposition of  
crystals of ent-isopimara-8(14),15-dien-3-one, LXXXI, (80 mg.).  
Recrystallisation yielded colourless, long rods, m.p.  $60^\circ$ ,  
 $[\alpha]_D +45^\circ$  (c 2), m/e 286 ( $M^+$ ).

(Found: C, 83.6; H, 10.5.  $C_{20}H_{30}O$  requires C, 83.9;  
H, 10.6%)

$\nu_{\max}$ . ( $CHCl_3$ ) 3078 ( $C=CH_2$ ), 1697 ( $C=O$ ) and 1630 ( $C=C$ )  $cm^{-1}$

$[\phi]$   $+2810^\circ$  (max., 315 nm.) and  $0^\circ$  (min., 280 nm.),

$\tau$  4.25 (1H, q, C-15 H,  $J_{\text{obs.}}$  10 and 18 Hz), 4.74 (1H,  
s, C-14 H), 5.12 (2H, m, 2xC-16 H), 8.93, 8.98, 8.98

and 9.02 (4x3H, 4xs, 1xMe).

The ketone, LXXXI, gave a 2,4-dinitrophenylhydrazone, m.p. 177-178°.

(Found: C, 66.8; H, 7.6.  $C_{26}H_{34}N_4O_4$  requires C, 66.9; H, 7.4%).

(Reported for isopimara-8(14),15-dien-3-one, LXXXV (b): m.p. 59-60°,  $[\alpha]_D -56^\circ$ ; 2,4-dinitrophenylhydrazone, m.p. 176.5-177° (100) ).

3 $\alpha$ -Hydroxy-ent-isopimara-8(14),15-dien-12-one, II, (0.1 g.) when oxidised with Jones reagent, as described above, yielded ent-isopimara-8(14),15-dien-3,12-dione, XCIV, (70 mg.) which crystallised as colourless, long spars, m.p. 84-85°,  $[\alpha]_D +312^\circ$  (c 1), m/e 300 ( $M^+$ ).

(Found: C, 79.8; H, 9.6.  $C_{20}H_{28}O_2$  requires C, 80.0; H, 9.4%)

$\nu_{max}$ . 3078 (C=CH<sub>2</sub>), 1695 s (C=O) and 1625 (C=C) cm.<sup>-1</sup>

$\lambda_{max}$ . 236 sh (2.48) and 295 nm. (2.32), unchanged on addition of base.

3 $\alpha$ ,12 $\alpha$ -Dihydroxy-ent-isopimara-8(14),15-diene, III, on oxidation with Jones reagent, yielded a diketone identical to ent-isopimara-8(14),15-dien-3,12-dione, XCIV.

3 $\alpha$ -Hydroxy-ent-isopimar-8(14)-ene, LXXVIII (a),



on oxidation with Jones' reagent followed by crystallisation of the product, gave colourless needles of ent-isopimar-8(14)-en-3-one, LXXXII, m.p. 59-60°,  $[\alpha]_D +12.5^\circ$ , m/e 288 ( $M^+$ ).

$\nu_{\max.}$  1695 (C=O)  $\text{cm.}^{-1}$

3 $\alpha$ -Hydroxy-ent-isopimarane, LXXIX, was oxidised with Jones reagent as described above to give colourless needles of ent-isopimaran-3-one, LXXXIII, m.p. 70-71°,  $[\alpha]_D -51.5^\circ$  (c 1), m/e 290 ( $M^+$ ).

(Found:  $M^+$ , m/e 290.259496.  $C_{20}H_{34}O$  requires  $M^+$ , m/e 290.260952)

$\nu_{\max.}$  1695 (C=O)  $\text{cm.}^{-1}$

$\lambda_{\max.}$  291 (1.32) nm.

3 $\alpha$ -Acetoxy-ent-isopimaran-12-ol, XCV, on oxidation with Jones reagent and crystallisation yielded colourless needles of 3 $\alpha$ -acetoxy-ent-isopimaran-12-one, XCVI, m.p. 105°,  $[\alpha]_D -61.3^\circ$  (c 2), m/e 348 ( $M^+$ ).

(Found: C, 75.9; H, 10.3.  $C_{22}H_{36}O_3$  requires C, 75.8; H, 10.4%)

$\nu_{\max.}$  1718 (acetate C=O), 1700 (C-12 C=O) and 1240 (ester C-O)  $\text{cm.}^{-1}$

$\tau$  5.51 (1H, m, C-3 H) and 7.80 (2H, q, 2xC-11 H).

Huang-Minlon (99) Reduction Products

3 $\alpha$ -Hydroxy-ent-isopimara-8(14),15-dien-3-one, II, (0.5 g.) and hydrazine hydrate (1.5 ml.) dissolved in a mixture of ethanol (1 ml.) and diethylene glycol (12 ml.) was refluxed for 30 min. before the addition of a concentrated solution of potassium hydroxide (3 g.) in water (3 ml.). The reaction mixture was refluxed for a further 90 min. after which the condenser was removed to allow the evaporation of water vapour. Heating was continued until the temperature reached 200° when refluxing was continued for 2 hr. The cooled mixture, on dilution with water, produced a flocculent precipitate which on repeated recrystallisation gave colourless needles of 3 $\alpha$ -hydroxy-ent-isopimara-8(14),15-diene, I, (0.35 g.), m.p. 128-129°,  $[\alpha]_D^{+13.5}$  (c 2). The infrared and mass spectra were identical to those obtained for the alcohol, I, isolated from the heartwood extract.

ent-Isopimara-8(14),15-dien-3-one, LXXXI, or ent-isopimara-8(14),15-dien-3,12-dione, XCIV, was reduced as described above to produce crude ent-isopimara-8(14),15-diene, LXXXIV. Crystallisation from light petroleum and chloroform yielded colourless crystals, m.p. 38-39°,  $[\alpha]_D^{+7}$  (c 1), m/e 272 ( $M^+$ ).

(Found:  $M^+$ , m/e 272.249103.  $C_{20}H_{32}$  requires  $M^+$ , m/e



272.250389).

(Reported for isopimara-8(14),15-diene, LXXXV (a): m.p. 40.5-41<sup>o</sup>,  $[\alpha]_D -12^{\circ}$  (100) ).

Reductions of the Ketol, II, to the Diol, III

(a) With LiAlH<sub>4</sub>

3 $\alpha$ -Hydroxy-ent-isopimara-8(14),15-dien-12-one, II, (0.5 g.) dissolved in ether (10 ml.) was added dropwise to a suspension of lithium aluminium hydride (1.5 g.) in dry ether (20 ml.). The mixture was heated under reflux for 20 hr., after which the excess reagent was decomposed by the addition of dilute sulphuric acid and heating at 100<sup>o</sup>. Separation and evaporation of the ether layer produced a colourless solid which crystallised as long rods of 3 $\alpha$ ,12 $\alpha$ -dihydroxy-ent-isopimara-8(14),15-diene, III, (0.3 g.), m.p. 161<sup>o</sup>,  $[\alpha]_D +24^{\circ}$  (c 1), m/e 304 (M<sup>+</sup>).

(Found: C, 79.1; H, 10.6. C<sub>20</sub>H<sub>32</sub>O<sub>2</sub> requires C, 78.9; H, 10.6%).

(b) With Sodium in Pentyl Alcohol (7)

Small portions of sodium (1.75 g.) were added to a refluxing solution of 3 $\alpha$ -hydroxy-ent-isopimara-8(14),15-dien-12-one, II, (0.5 g.) in pentyl alcohol (40 ml.). After all the metal had dissolved the mixture was steam-distilled to remove all the alcohol. From the aqueous suspension a flocculent precipitate was filtered off to yield, on



crystallisation, colourless rods of 3 $\alpha$ ,12 $\alpha$ -dihydroxy-ent-isopimara-3(14),15-diene, III, (0.4 g.).

The infrared and mass spectra of both reduction products were superimposable on those of the diol, III, obtained from the heartwood extract, while mixed melting points of both with an authentic sample of III were un-depressed.

#### Bromination Products

ent-Isopimaran-3-one, LXXXIII, (0.1 g.) dissolved in dry benzene (10 ml.) was treated dropwise with a solution of bromine (50 mg.) in benzene (3 ml.). The initial slow uptake of bromine was followed by a more rapid absorption. The reaction appeared to be complete after 30 min. after which the benzene was evaporated to give a gum. Crystallisation afforded colourless needles of 1 $\alpha$ ,2 $\beta$ -dibromo-ent-isopimaran-3-one, LXXXIX, (95 mg.), m.p. 115-116 $^{\circ}$ ,  $[\alpha]_D -10^{\circ}$  (c 1), m/e 446, 448, 450 ( $M^+$ ).

(Found: C, 53.5; H, 7.2. C<sub>20</sub>H<sub>32</sub>OBr<sub>2</sub> requires C, 53.6; H, 7.1%)

$\nu_{\max}$ . 1720 (C=O) cm.<sup>-1</sup>

$\tau$  6.25 and 6.92 (2H, 2xd, C-1 and C-2 H,  $J_{\text{obs}}$ . 16 Hz).

ent-Isopimaran-3-one, LXXXIII, (0.1 g.) dissolved in glacial acetic acid (10 ml.) was treated dropwise with

a solution of bromine (50 mg.) in glacial acetic acid containing one drop of acetic acid saturated with HBr. After the colour was discharged (10 min.) dilution with ice-water induced the precipitation of pale yellow crystals which were filtered and washed with dilute aqueous sodium thiosulphate. The crystals were shown by t.l.c. to be a mixture of the mono- and dibromo compounds. These components were separated by means of preparative t.l.c. Recrystallisation furnished colourless needles of 2 $\beta$ -bromo-ent-isopimaran-3-one, LXXXVIII, (80 mg.), m.p. 101-102 $^{\circ}$ , m/e 368, 370 ( $M^+$ ).

(Found:  $M^+$ , m/e 368.170117.  $C_{20}H_{33}OBr$  requires  $M^+$ , m/e 368.171342)

$\nu_{\max}$ . 1720 (C=O)  $cm^{-1}$

$\tau$  4.99 (1H, m, C-2 H).

3 $\alpha$ -Acetoxy-ent-isopimaran-12-one, XCVI, (120 mg.) dissolved in glacial acetic acid (15 ml.) was treated dropwise with a solution of bromine (50 mg.) in acetic acid (3 ml.). The mixture was set aside for 5 days at room temperature, after which dilution with ice-water yielded a pale yellow precipitate which was filtered and washed with dilute aqueous sodium thiosulphate. Crystallisation of the precipitate (100 mg.) afforded colourless flakes of 3 $\alpha$ -acetoxy-11 $\beta$ -bromo-ent-isopimaran-12-one, XCVII, m.p. 149-150 $^{\circ}$ ,  $[\alpha]_D^{-34}$  (c 1), m/e 426, 428 ( $M^+$ ).



(Found: C, 61.6; H, 8.4.  $C_{22}H_{35}O_3Br$  requires C, 61.8; H, 8.2%)

$\nu_{\max.}$  1720 (acetate C=O), 1695 (C-12 C=O) and 1245 (ester C-O)  $cm^{-1}$

$\lambda_{\max.}$  325 nm. (1.89)

$\tau$  5.49 (1H, m, C-3 H), 6.00 (1H, d, C-11 H,  $J_{\text{obs.}}^4$  Hz), 7.97 (3H, s,  $CH_3C=O$ ), 8.95, 9.15, 9.16 and 9.22 (4x3H, 4xs, 4xMe).

#### Dehydrobromination of the bromoketone, XCVII

A mixture of 3 $\alpha$ -acetoxy-11 $\beta$ -bromo-ent-isopimarane-12-one, XCVII, (0.2 g.), lithium carbonate (0.2 g.) and lithium bromide (0.25 g.) in dimethylformamide (8 ml.) was heated under reflux for 90 min. under a stream of nitrogen. Dilution of the cooled reaction mixture with water yielded colourless crystals of the  $\alpha, \beta$ -unsaturated ketone (0.1 g.). Recrystallisation gave small plates of 3 $\alpha$ -acetoxy-ent-isopimar-9(11)-en-12-one, m.p. 143-145 $^{\circ}$ ,  $[\alpha]_D^{25}$  -38 $^{\circ}$  (c 1), m/e 346 ( $M^+$ ).

(Found: C, 76.3; H, 9.9.  $C_{22}H_{34}O_3$  requires C, 76.3; H, 9.9%)

$\nu_{\max.}$  3048 (C=C-H), 1729 (acetate C=O), 1657 (C-12 C=O), 1603 (C=C) and 1235 (ester C-O)  $cm^{-1}$

$\lambda_{\max.}$  239 (4.16) nm.



$\tau$  4.31 (1H, d, C-11 H,  $J_{11,8} 2$  Hz), 5.52 (1H, m, C-3 H),  
7.40 (1H, m, C-8 H), 7.97 (3H, s,  $\text{CH}_3\text{C}=\text{O}$ ), 8.87, 9.03,  
9.07 and 9.13 (4x3H, 4xs, 4xMe).

Attempted Preparation of the Isopropylidenedioxy derivative  
from the Diol, III

3 $\alpha$ ,12 $\alpha$ -Dihydroxy-ent-isopimara-8(14),15-diene,  
III, (50 mg.) dissolved in acetone (5 ml.) and conc.  
hydrochloric acid (1 drop) was set aside overnight at 0 $^\circ$ .  
On dilution with water the product was recovered unchanged.

Isopimara-8(14),15-dien-3-one

A sample of this compound was obtained for purposes  
of comparison with the enantiomer, LXXXI. The compound had  
m.p. 59-60 $^\circ$ ,  $[\phi] -2460^\circ$  (max., 315 nm.) and 0 $^\circ$  (min., 280 nm.),  
and its infrared and mass spectra were superimposable on  
those of LXXXI.

Preparation of Jones' Reagent (97)

A cold solution of chromic oxide (26.7 g.) in conc.  
sulphuric acid (23 ml.) and distilled water (40 ml.) was made  
up to 100 ml. with water. This solution is 8 N with respect  
to oxygen.

PART 2 SPIROSTACHYS AFRICANASource and Extraction of the Heartwood Diterpenes

The heartwood was obtained from two trees of Spirostachys africana Sond. (syn. Excoecaria africana Muell. Arg.), Family Euphorbiaceae, which had been collected near Hluhluwe and Inanda, Natal. Botanical specimens of each were deposited at the Natal Herbarium, Durban, under the numbers NH52617 A and 52617 B. The light petroleum extracts from both trees were shown to be identical by comparative thin layer chromatography.

The milled, air-dried heartwood (641 g.) was placed in a soxhlet extractor and washed through with three portions (2 l. each) of cold light petroleum. These washings were combined and, on evaporation, produced a yellow syrup (98 g.). Exhaustive extraction of the wood with refluxing light petroleum (24 hr.) followed by evaporation of the solvent resulted in a dark orange syrup (10 g.) which was similar in composition to the cold extract.

Portions of the cold light petroleum extract (10 g.) dissolved in light petroleum-benzene (4:1, 40 ml.) were chromatographed on columns of silica gel (200 g., 0.05-0.2 mm.) to effect a preliminary separation of the components. Elution with light petroleum yielded a wax-like substance thought to be a long-chain fatty acid. The addition of benzene (10%) to the eluant produced a waxy solid found to be a mixture of two compounds. Further elution with a



mixture of benzene-light petroleum (1:1) produced a solid ascertained to be a mixture of three components, whilst increasingly polar solvents failed to effect a separation of the remaining constituents.

Beyer-15-en-3-one, V

The waxy solid (0.5 g.) obtained from the preliminary separation was rechromatographed on silica gel (25 g., 0.08 mm.) using light petroleum as eluant. The first 4 fractions collected furnished crystals of beyer-15-en-3-one, V, (0.1 g.) which, on recrystallisation from light petroleum, gave colourless needles, m.p. 40-41<sup>o</sup>,  $[\alpha]_D^{+27}$  (c 1), m/e 286 (M<sup>+</sup>).

(Found: C, 84.1; H, 10.8. C<sub>20</sub>H<sub>30</sub>O requires C, 83.9; H, 10.6%)

$\nu_{\max}$ . 3045 (H-C=C-H), 1702 (C=O), 748 (C=C) cm.<sup>-1</sup>

$\lambda_{\max}$ . 288 (1.62) nm.

The 2,4-dinitrophenylhydrazone was recrystallised from ethanol to give orange needles, m.p. 194-196<sup>o</sup>.

(Reported for beyer-15-en-3-one, V, (7): m.p. 35-36.5<sup>o</sup>,  $[\alpha]_D^{+22}$ , 2,4-dinitrophenylhydrazone m.p. 194-196<sup>o</sup>).

Hydrogenation of beyer-15-en-3-one, V

Beyer-15-en-3-one, V, (5 mg.) was hydrogenated over palladium-carbon catalyst (2 mg., 30%) in ethanol (2 ml.) until no further absorption was observed. One mole



of  $H_2$  was absorbed to give beyeran-3-one which crystallised from light petroleum as colourless needles, m.p.  $63-64^\circ$  and failed to react with tetranitromethane.

3-Hydroxybeyer-15-en-2-one, VI

The next 3 fractions eluted produced a colourless compound on evaporation. Crystallisation from light petroleum afforded needles of 3-hydroxybeyer-15-en-2-one, VI, (50 mg.), m.p.  $128-129^\circ$ ,  $[\alpha]_D^{25} +34^\circ$  (c 1), m/e 302 ( $M^+$ ).

$\nu_{\max.}$  3460 (O-H), 1712 (C=O) and 745 (C=C)  $cm^{-1}$

$\lambda_{\max.}$  286 (1.5) nm.

2-Hydroxybeyera-1,15-dien-3-one, VII

The mixture originally obtained from the preliminary separation of the crude extract was dissolved in light petroleum (50 ml.) and extracted with a solution of potassium hydroxide (0.2 g.) in aqueous ethanol (2:3, 60 ml.). The aqueous layers were in turn extracted with light petroleum (30 ml.), and the combined organic layers, on concentration and cooling, yielded crude 2-hydroxybeyera-1,15-dien-3-one (10 mg.), m.p.  $129-131^\circ$ .

$\lambda_{\max.}$  271 (3.96) nm.

EtOH+KOH

$\lambda_{\max.}$  316 (3.7) nm.

On treatment with neutral ferric chloride a

mauve-brown colour was observed indicative of a diosphenol.

2,3-Secobeyer-15-en-2,3-dioic acid, VIII

Portions (10 g.) of light petroleum extract dissolved in light petroleum (50 ml.) were subjected to partition by means of counter-current extraction along 12 tubes in which the phases were light petroleum (2 l.) and potassium hydroxide (10 g.) in aqueous ethanol (1:1, 2 l.), which had been previously shaken and set aside for 2 hr. to allow mutual saturation of the two phases. The aqueous layers from the first four tubes were collected and acidified with conc. hydrochloric acid. This resulted in the deposition of colourless crystals which were filtered and recrystallised from dilute acetic acid to give needles of 2,3-secobeyer-15-en-2,3-dioic acid, VIII, (2 g.), m.p. 217-218°,  $[\alpha]_D^{29} (c 2)$ , m/e 334 ( $M^+$ ).

(Found: C, 71.8; H, 8.8.  $C_{20}H_{30}O_4$  requires C, 71.8; H, 9.0%)

$\nu_{\max}$ . 2653 (COOH), 1718 and 1685 (C=O) and 746 (C=C)  $cm^{-1}$

$\tau$  4.35 and 4.55 (2H, 2xd, C-15 and C-16 H,  $J_{\text{obs.}}$  6 Hz),  
8.76, 8.83, 9.01 and 9.15 (4x3H, 4xs, 4xMe).

Accurate mass measurements of major fragments in the mass spectrum substantiated the structure assigned to the diacid, VIII.

Found: m/e. 187.147869 (M-147).  $C_{14}H_{19}$  requires m/e, 187.148668.



Found: m/e, 247.170782 (M-87).  $C_{16}H_{23}O_2$  requires m/e, 247.169795.

Found: m/e, 275.198895 (M-59).  $C_{18}H_{27}O_2$  requires m/e, 275.201094.

Hydrogenation of 2,3-Secobeyer-15-en-2,3-dioic acid, VIII

2,3-Secobeyer-15-en-2,3-dioic acid, VIII, (5.4 mg.) was hydrogenated over platinum oxide catalyst (3 mg.) in glacial acetic acid (2 ml.) and after the absorption of 0.43 ml.  $H_2$ , further uptake ceased (theoretical for 1 mole, 0.38 ml.). Crystallisation of the product yielded colourless needles of 2,3-secobeyeran-2,3-dioic acid, CVII, m.p.  $215^\circ$ ,  $[\alpha]_D^{-20}$  (c 1), m/e 336 ( $M^+$ ).

(Found: C, 71.5; H, 9.6.  $C_{20}H_{32}O_4$  requires C, 71.4; H, 9.6%),

$\nu_{max.}$  2657 (COOH), 1710 and 1688 (C=O)  $cm^{-1}$

$\tau$  8.68, 8.80, 8.92 and 9.04 (4x3H, 4xs, 4xMe).

Hydrogenation in ethanolic medium proceeded less rapidly than in the above-mentioned case, but gave rise to the same product.

Methylation of 2,3-Secobeyer-15-en-2,3-dioic acid, VIII

(a) Fischer-Speier Method (132)

2,3-Secobeyer-15-en-2,3-dioic acid, VIII, (0.1 g.) dissolved in dry methanol (10 ml.) and conc. sulphuric acid (3 drops) was refluxed for 15 hr. Dilution of the cooled



mixture with ice-water produced a white precipitate which, after repeated crystallisations, afforded colourless needles of the monomethyl ester, CVIII, (90 mg.), m.p.  $120^{\circ}$ ,  $[\alpha]_D -10^{\circ}$  (c 1), m/e 348 ( $M^+$ ).

(Found: C, 72.7; H, 9.2.  $C_{21}H_{32}O_4$  requires C, 72.9; H, 9.4%)

$\nu_{\max}$ . 2653 (COOH), 1740 (ester C=O), 1685 (acid C=O) and 748 (C=C)  $\text{cm}^{-1}$

(b) With Diazomethane

2,3-Secobeyer-15-en-2,3-dioic acid, VIII, (0.1 g.) dissolved in ether (10 ml.) at  $5^{\circ}$  was treated dropwise with cold ethereal diazomethane until the evolution of gas ceased and a yellow colour persisted. The mixture was set aside for 2 hr. after which the ether was evaporated under reduced pressure. The resultant colourless gum could not be induced to crystallise, but was determined to be the dimethyl ester, CIX, by the presence of the molecular ion peak at m/e 362 ( $M^+$  for  $C_{22}H_{34}O_4$ ). Its intensity (1%) was unfortunately too low to allow an accurate mass measurement, but measurements of the major fragments substantiated the structural assignment. Found: m/e, 261.184590 (M-101).  $C_{17}H_{25}O_2$  requires m/e, 261.185445. Found: m/e, 289.217930 (M-73).  $C_{19}H_{29}O_2$  requires m/e, 289.216743.

Reduction of 2,3-Secobeyer-15-en-2,3-dioic acid, VIII

2,3-Secobeyer-15-en-2,3-dioic acid, VIII, (1 g.) dissolved in dry ether (25 ml.) was gradually added to a suspension of lithium aluminium hydride (3 g.) in dry ether (30 ml.) and refluxed for 12 hr. Excess of  $\text{LiAlH}_4$  was then destroyed by the addition of dilute sulphuric acid and gentle warming. The ethereal layer was separated and evaporated to a gum which, on filtration through a short silica gel column, yielded colourless crystals of 2,3-secobeyer-15-en-2,3-diol, CX. Recrystallisation from light petroleum-ethanol (9:1) furnished needles, (0.2 g.), m.p.  $129-130^\circ$ , m/e 306 ( $\text{M}^+$ ).

(Found: C, 78.1; H, 11.2.  $\text{C}_{20}\text{H}_{34}\text{O}_2$  requires C, 78.4; H, 11.2%)

$\nu_{\text{max}}$ . 3338 (O-H) and 748 (C=C)  $\text{cm}^{-1}$

Anhydride Formation

2,3-Secobeyer-15-en-2,3-dioic acid, VIII, (0.1 g.) was refluxed with acetic anhydride (5 ml.) for 1 hr. Evaporation of the solvent under reduced pressure resulted in a gum which crystallised from light petroleum as colourless rods of the anhydride, CXI, (50 mg.), m.p.  $129-130^\circ$ , m/e 316 ( $\text{M}^+$ ).

(Found: C, 75.8; H, 8.9.  $\text{C}_{20}\text{H}_{28}\text{O}_3$  requires C, 75.9; H, 8.9%)

$\nu_{\max.}$  1796 and 1758 (anhydride C=O) and 746 (C=C)  $\text{cm.}^{-1}$

$\tau$  4.35 and 4.52 (2H, 2xd, C-15 and C-16 H), 8.67, 8.75, 8.98 and 9.08 (4x3H, 4xs, 4xMe).

2,3-Secobeyeran-2,3-dioic acid, CVII, (50 mg.) was refluxed with acetic anhydride (3 ml.) for 1 hr. The solvent was removed under reduced pressure to give a yellow gum which, on repeated crystallisations from light petroleum, gave colourless needles of the anhydride, CXII, (20 mg.), m.p. 122-123°, m/e 318 ( $M^+$ ).

(Found: C, 75.2; H, 9.6.  $C_{20}H_{30}O_3$  requires C, 75.4; H, 9.5%)

$\nu_{\max.}$  1792 and 1750 (anhydride C=O)  $\text{cm.}^{-1}$

$\tau$  8.67, 8.76, 8.93 and 9.03 (4x3H, 4xs, 4xMe).

#### Preparation of Ethereal Diazomethane (140)

An aqueous solution of 40% potassium hydroxide (1.5 ml.) was added to ether (5 ml.) and the mixture cooled in ice. To this was added portions of finely powdered nitrosomethylurea (0.5 g.) with continued cooling and shaking. The deep yellow ethereal layer containing diazomethane (0.14 g.) was used for methylating the seco-diacid, VIII.



Determination of the Number of Carboxyl Groups in  
2,3-secobeyer-15-en-2,3-dioic acid, VIII

Normality of NaOH standardised with benzoic acid

$$=0.0091 \text{ N}$$

Molarity of 10 ml. aliquots of VIII in methanol

$$=0.011 \text{ M}$$

	1st titration	2nd titration
Volume NaOH	22.6 ml.	22.8 ml.

Average titration value =22.7 ml. using phenolphthalein  
 as indicator.

$$\therefore 0.011 \text{ M} = \frac{22.7}{10} \times 0.0091 \text{ equivalents}$$

$$= 0.0206 \text{ N}$$

$\therefore$  2,3-secobeyer-15-en-2,3-dioic acid, VIII, contains  
 two carboxyl groups per molecule.

REFERENCE ABBREVIATIONS

Acta Chem. Scand.	Acta Chemica Scandinavica
Anal. Chem.	Analytical Chemistry
Arch. Pharm.	Archiv der Pharmazie
Austral. J. Chem.	Australian Journal of Chemistry
Berichte	Berichte der deutschen chemischen Gesellschaft.
Bull. Imp. Inst.	Bulletin of the Imperial Institute
Bull. Inst. Chem. Research	Bulletin of the Institute for Chemical Research
Bull. Soc. Chim. France	Bulletin de la Societe chimique de France
Canad. J. Chem.	Canadian Journal of Chemistry
Chem. Comm.	Chemical Communications
Chem. and Ind.	Chemistry and Industry
Coll. Czech. Chem. Comm.	Collection of Czechoslovak Chemical Communications
East African Agric. J.	East African Agricultural Journal
Helv. Chim. Acta	Helvetica Chimica Acta
Ind. J. Chem.	Indian Journal of Chemistry
J. Amer. Chem. Soc.	Journal of the American Chemical Society
J. Chem. Phys.	Journal of Chemical Physics
J. Chem. Soc.	Journal of the Chemical Society

J. Chem. Soc. (B)	Journal of the Chemical Society, Section B, Physical Organic Chemistry
J. Chem. Soc. (C)	Journal of the Chemical Society, Section C, Organic Chemistry
J. Chromatog.	Journal of Chromatography
J. Org. Chem.	Journal of Organic Chemistry
Proc. Chem. Soc.	Proceedings of the Chemical Society
Proc. Roy. Soc.	Proceedings of the Royal Society
S.A. Ind. Chem.	South African Industrial Chemist
Spectrochim. Acta	Spectrochimica Acta
Tet. Letters	Tetrahedron Letters

### Books

Applications of NMR Spec. in Org. Chem.

Applications of NMR Spectroscopy  
in Organic Chemistry, Holden-Day,  
Inc., San Francisco, 1964.

Chem. App. of IR Spec.

Chemical Applications of  
Infrared Spectroscopy, Academic  
Press, New York, 1963.

Interp. of the UV Spectra of Natural Products.

Interpretation of Ultraviolet  
Spectra of Natural Products,  
Pergamon Press, Ltd., 1964.



Spectrometric Ident. of Org. Cmpds.

Spectrometric Identification of  
Organic Compounds, John Wiley  
and Sons, Inc., New York and  
London, 1963.

REFERENCES

1. E. J. McGarry                    Ph.D. Thesis, 1969, University of Natal, Durban.
2. E. J. McGarry, K. H. Pegel, L. Phillips and E. S. Waight, Chem. Comm., 1969, 1074.
3. E. J. McGarry, K. H. Pegel, L. Phillips and E. S. Waight, J. Chem. Soc. (C), 1971, 904.
4. Anonymous, Bull. Imp. Inst., 1935, 33, 136.
5. Beckley, East African Agric. J., 1936, 1, 469.
6. W. H. Baarschers and D. H. S. Horn, S.A. Ind. Chem., 1962, 16, 122.
7. W. H. Baarschers, D. H. S. Horn and L. R. F. Johnson, J. Chem. Soc., 1962, 4046.
8. J. A. Barltrop and N. A. J. Rogers, "The Chemistry of the Higher Terpenes" in Progress in Organic Chemistry, Vol. 5, Butterworths, London, 1961.
9. P. de Mayo, "The Higher Terpenoids" in The Chemistry of Natural Products, Vol. 3, Interscience, New York, 1959.
10. E. Fujita, Bull. Inst. Chem. Research, Kyoto University, 1965, 43, 278.
11. E. Fujita, Bull. Inst. Chem. Research, Kyoto University, 1966, 44, 239.

12. E. Fujita, Bull. Inst. Chem. Research, Kyoto University, 1967, 45, 229.
13. R. McCrindle and K. H. Overton, Advances in Organic Chemistry, Vol. 5, p. 47-113, Interscience, J. Wiley and Sons, New York, 1965.
14. A. Eschenmoser, L. Ruzicka, O. Jeger and D. Arigoni, Helv. Chim. Acta, 1959, 38, 1890.
15. J. L. Simonsen and D. H. R. Barton, The Terpenes, Vol. 3, p. 350, 360, 368, Cambridge University Press, London, 1952.
16. J. L. Simonsen and P. de Mayo, The Terpenes, Vol. 5, p. 598-602, Cambridge University Press, London, 1957.
17. P. de Mayo, The Chemistry of Natural Products, Vol. 3, p. 32, Interscience, New York, 1959.
18. M. Soucek and P. Vlad, Coll. Czech. Chem. Comm., 1963, 28, 1211.
19. R. Hodges and R. I. Reed, Tetrahedron, 1960, 10, 71.
20. C. A. Henrick and P. R. Jefferies, Tetrahedron, 1965, 21, 1175.



21. C. A. Henrick and P. R. Jefferies,  
Tetrahedron, 1965, 21, 3219.
22. E. M. Graham and K. H. Overton,  
J. Chem. Soc., 1965, 126.
23. C. A. Henrick and P. R. Jefferies,  
Chem. and Ind., 1963, 1801.
24. C. A. Henrick and P. R. Jefferies,  
Chem. and Ind., 1963, 1802.
25. C. A. Henrick and P. R. Jefferies,  
Austral. J. Chem., 1964, 17, 908.
26. P. R. Jefferies and T. G. Payne,  
Austral. J. Chem., 1965, 18, 1441.
27. T. G. Halsall, A. W. Oxford and W. Rigby,  
Chem. Comm., 1965, 218.
28. C. E. McEachan, A. T. McPail and G. A. Sim,  
J. Chem. Soc. (B), 1966, 633.
29. J. S. Birtwistle, D. E. Case, P. D. Dutta, T. G. Halsall,  
G. Mathews, H. D. Sabel and V. Thaller,  
Proc. Chem. Soc., 1962, 329.
30. G. C. Harris and T. F. Sanderson,  
J. Amer. Chem. Soc., 1948, 70, 2079.
31. L. Ruzicka and L. Sternbach,  
Helv. Chim. Acta, 1940, 23, 124.
32. E. Wenkert and J. W. Chamberlain,  
J. Amer. Chem. Soc., 1959, 81, 688.
33. O. E. Edwards and R. Howe,  
Canad. J. Chem., 1959, 37, 760.

34. B. Green, A. Harris and W. B. Whalley,  
Chem. and Ind., 1958, 1084.
35. H. H. Bruun, R. Ryhage and E. Stenhagen,  
Acta Chem. Scand., 1958, 12, 789.
36. H. H. Bruun, I. Fischmeister and E. Stenhagen,  
Acta Chem. Scand., 1959, 13, 379.
37. B. Green, A. Harris and W. B. Whalley,  
J. Chem. Soc., 1958, 4715.
38. O. E. Edwards and R. Howe,  
Chem. and Ind., 1959, 537.
39. A. K. Bose and W. A. Struck,  
Chem. and Ind., 1959, 1628.
40. G. W. A. Milne and H. Smith,  
Chem. and Ind., 1961, 1307.
41. O. E. Edwards, A. Nicolson and M. N. Rodger,  
Canad. J. Chem., 1960, 38, 663.
42. A. K. Bose,  
Chem. and Ind., 1960, 1104.
43. R. E. Ireland and P. W. Schiess,  
Tet. Letters., 1960, (25), 37.
44. R. E. Ireland and P. W. Schiess,  
J. Org. Chem., 1963, 28, 6.
45. R. E. Ireland and J. Newbould,  
J. Org. Chem., 1963, 28, 23.
46. R. F. Church and R. E. Ireland,  
Tet. Letters, 1961, (14), 493.
47. R. F. Church and R. E. Ireland,  
J. Org. Chem., 1963, 28, 17.



48. W. Antkowiak, O. E. Edwards, R. Howe and J. W. ApSimon,  
Canad. J. Chem., 1965, 43, 1257.
49. C. Asselineau, S. Bory and A. Diara,  
Bull. Soc. Chim. France, 1964, 1197.
50. J. W. ApSimon, P. V. Demarco and J. Lemke,  
Canad. J. Chem., 1965, 43, 2793.
51. W. Herz and R. N. Mirrington,  
J. Org. Chem., 1965, 30, 3198.
52. L. H. Briggs, B. F. Cain, B. R. Davis and J. K. Wilmhurst,  
Tet. Letters, 1959, (8), 13.
53. R. E. Corbett and S. G. Wyllie,  
Tet. Letters, 1964, (29), 1903.
54. J. D. Connolly, R. McCrindle, R. D. H. Murray and  
K. H. Overton, Tet. Letters, 1964, (29), 1983.
55. R. E. Ireland and L. N. Mander,  
Tet. Letters, 1964, (46), 3453.
56. W. Herz and R. N. Mirrington,  
J. Org. Chem., 1965, 30, 3195.
57. W. Herz and R. N. Mirrington,  
J. Org. Chem., 1965, 30, 4338.
58. P. W. Chow and P. R. Jefferies,  
Austral. J. Chem., 1968, 21, 2529.
- 59a. V. N. Aiyar and T. R. Seshadri,  
Tetrahedron, 1970, 26, 5275.
- 59b. P. S. Rao, G. P. Sachdev, T. R. Seshadri and H. B. Singh,  
Tet. Letters, 1968, (45), 4685.



- 59c. V. N. Aiyar, P. S. Rao, G. P. Sachdev and T. R. Seshadri,  
Ind. J. Chem., 1969, 838.
60. J. R. Hanson, The Tetracyclic Diterpenes, Vol. 9,  
p. 2,3, Pergamon Press, London, 1968.
61. E. Wenkert, Chem. and Ind., 1955, 282.
62. E. Wenkert, P. W. Jeffs and J. R. Mahajan,  
J. Amer. Chem. Soc., 1964, 86, 2218.
63. Y. Kitahara and A. Yoshikoshi,  
Tet. Letters, 1964, (26), 1771.
64. R. E. Ireland and L. N. Mander,  
Tet. Letters, 1965, (30), 2627.
65. P. R. Jefferies, R. S. Rosich, D. E. White and M. C. Woods,  
Austral. J. Chem., 1962, 15, 521.
66. P. R. Jefferies, R. S. Rosich and D. E. White,  
Tet. Letters, 1963, (26), 1793.
67. G. V. Baddeley, M. W. Jarvis, P. R. Jefferies and  
R. S. Rosich, Austral. J. Chem., 1964, 17, 578.
68. G. V. Baddeley, P. R. Jefferies and R. W. Retallack,  
Tetrahedron, 1964, 20, 1983.
69. C. A. Henrick and P. R. Jefferies,  
Austral. J. Chem., 1964, 17, 915.
70. P. R. Jefferies and T. G. Payne,  
Austral. J. Chem., 1965, 18, 1441.
71. C. A. Henrick and P. R. Jefferies,  
Austral. J. Chem., 1965, 18, 2005.
72. C. A. Henrick and P. R. Jefferies,  
Tet. Letters, 1964, (24), 1507.

73. E. L. Ghisalberti and P. R. Jefferies,  
Tet. Letters, 1966, (51), 6323.
74. E. L. Ghisalberti and P. R. Jefferies,  
Austral. J. Chem., 1968, 21, 439.
75. P. R. Jefferies and R. W. Retallack,  
Austral. J. Chem., 1968, 21, 1311.
76. P. R. Jefferies and R. W. Retallack,  
Austral. J. Chem., 1968, 21, 2085.
77. E. L. Ghisalberti and P. R. Jefferies,  
Austral. J. Chem., 1966, 19, 1759.
78. L. H. Briggs, R. W. Cawley, J. A. Loe and W. I. Taylor,  
J. Chem. Soc., 1950, 955.
79. F. von Breitenbach, The Indigenous Trees of South Africa,  
Vol. 3, p. 499, The Government  
Printer, Pretoria, 1965.
80. E. H. Rodd, The Chemistry of Carbon Compounds,  
Vol. 2b, p. 836, Elsevier Press Inc.,  
New York, 1953.
81. A. Werner, Berichte., 1909, 42, 4324.
82. C. N. R. Rao, Chem. App. of IR Spec., p. 178.
83. A. W. Stewart and G. B. Sutherland,  
J. Chem. Phys., 1956, 24, 559.
84. S. Krimm, C. Y. Liang and G. B. Sutherland,  
J. Chem. Phys., 1956, 24, 778.
85. C. N. R. Rao, Chem. App. of IR Spec., p. 187.
86. A. R. H. Cole, R. N. Jones and K. Dobriner,  
J. Amer. Chem. Soc., 1952, 74, 5571.



87. H. Rosenkrantz and L. Zablow,  
J. Amer. Chem. Soc., 1953, 75,  
897.
88. I. L. Allsop, A. R. H. Cole, D. E. White and  
R. L. S. Willis, J. Chem. Soc., 1956, 4868.
89. L. J. Bellamy, The Infrared Spectra of Complex  
Molecules, 2nd edition, J. Wiley  
and Sons, New York, 1958.
90. C. N. R. Rao, Chem. App. of IR Spec., p. 148.
91. N. S. Bhacca and D. H. Williams,  
Applications of NMR Spec. in Org.  
Chem., p. 85.
92. M. Karplus, J. Chem. Phys., 1959, 30, 6.
93. M. Karplus and D. H. Anderson,  
J. Chem. Phys., 1959, 30, 11.
94. D. J. Collins, J. J. Hobbs and S. Sternhell,  
Austral. J. Chem., 1963, 16, 1030.
95. N. S. Bhacca and D. H. Williams,  
Applications of NMR Spec. in Org.  
Chem., p. 108.
96. N. S. Bhacca and D. H. Williams,  
Applications of NMR Spec. in Org.  
Chem., p. 78.
97. R. G. Curtis, I. Heilbron, E. R. H. Jones and G. Woods,  
J. Chem. Soc., 1953, 457.
98. D. H. R. Barton and P. de Mayo,  
J. Chem. Soc., 1954, 887.



99. Huang-Minlon, J. Amer. Chem. Soc., 1949, 71, 3303.
100. R. A. Laidlaw and J. W. W. Morgan,  
J. Chem. Soc., 1963, 644.
101. C. Djerassi, Optical Rotatory Dispersion, p. 14,  
McGraw-Hill Book Co. Inc., New York,  
1966.
102. C. R. Enzell and S. R. Wallis,  
Tet. Letters, 1966, (2), 244.
103. H. E. Audier, S. Bory, M. Fetizon and N-T Anh,  
Bull. Soc. Chim. France, 1966, (72),  
4002.
104. N. S. Bhacca and D. H. Williams,  
Applications of NMR Spec. in Org.  
Chem., p. 51.
105. A. Nickon, M. A. Castle, R. Harada, C. E. Berkoff and  
R. O. Williams, J. Amer. Chem. Soc., 1963, 85, 2185.
106. K. M. Wellman and F. G. Bordwell,  
Tet. Letters, 1963, (25), 1703.
107. L. F. Fieser and M. Fieser,  
Advanced Organic Chemistry, p. 412,  
Reinhold Publishing Corp., New  
York, Maruzen Asian Edition, 1961.
108. W. Shoppee, Chemistry of the Steroids, p. 73,  
Butterworths Scientific Publications,  
London, 1958.
- 109a. E. J. Corey, J. Amer. Chem. Soc., 1953, 75, 2301.
- 109b. E. J. Corey, J. Amer. Chem. Soc., 1954, 76, 175.

110. C. R. Enzell and R. Ryhage,  
Arkiv for Kemi, 1965, 23, 367.
111. V. I. Zaretskii, N. S. Wulfson, V. G. Zaikin, L. M. Kogan,  
N. E. Voishvillo and I. V. Torgov,  
Tetrahedron, 1966, 22, 1399.
112. C. N. R. Rao, Chem. App. of IR Spec., p. 201.
- 113a. F. Feigl, Spot Tests in Organic Analysis,  
p. 389, Elsevier Publishing Co.,  
5th edition, Amsterdam, 1956.
- 113b. H. Auterhoff and G. Zeisner,  
Arch. Pharm., 1953, 286/58, 525.
114. A. I. Scott, Interp. of the UV Spectra of Natural  
Products, p. 36-37.
115. A. I. Scott, Interp. of the UV Spectra of Natural  
Products, p. 28.
116. D. H. R. Barton, P. de Mayo and J. C. Orr,  
J. Chem. Soc., 1958, 2239.
117. R. C. Cookson, J. Chem. Soc., 1954, 282.
118. E. L. Erskine and E. S. Waight,  
J. Chem. Soc., 1960, 3425.
119. A. I. Scott, Interp. of the UV Spectra of Natural  
Products, p. 58.
120. N. S. Bhacca and D. H. Williams,  
Applications of NMR Spec. in Org.  
Chem., p. 190.
121. R. M. Silverstein and G. C. Bassler,  
Spectrometric Ident. of Org. Cmpds.,  
p. 13.



122. J. M. Coxon, M. P. Hartshorn and D. N. Kirk,  
Tetrahedron, 1967, 23, 3511.
123. J. N. Hoffman and J. T. Charles,  
J. Amer. Chem. Soc., 1968, 90,  
6486.
124. B. deWinter, M. deWinter and D. J. B. Killick,  
Sixty-Six Transvaal Trees, p. 98,  
Voortrekker Pers, Pretoria, 1966.
125. C. N. R. Rao, Chem. App. of IR Spec., p. 222-5.
126. S. Bratoz, D. Hadzi and N. Sheppard,  
Spectrochim. Acta, 1956, 8, 249.
127. D. Hadzi and N. Sheppard,  
Proc. Roy. Soc., 1953, A216, 247.
128. C. N. R. Rao, Chem. App. of IR Spec., p. 139.
129. W. Bottomley, A. R. H. Cole and D. E. White,  
J. Chem. Soc., 1955, 2626.
130. R. M. Silverstein and G. C. Bassler,  
Spectrometric Ident. of Org. Cmpds.,  
p. 78.
131. J. R. Hanson, The Tetracyclic Diterpenes, Vol.  
9, p. 60, Pergamon Press, London,  
1968.
132. E. Fischer and A. Speier,  
Berichte, 1895, 28, 3252.
133. E. D. Hughes, Quarterly Reviews, 1948, 2, 107.
134. A. G. Sharkey Jr., J. L. Schultz and R. A. Friedel,  
Anal. Chem., 1959, 31, 87.



135. R. Ryhage and E. Stenhagen,  
Mass Spectrometry of Organic Ions,  
Chapter 9, Academic Press, New  
York, 1963.
136. F. W. McLafferty, Anal. Chem., 1959, 31, 82.
137. A. B. Rendle, The Classification of Flowering  
Plants, Vol. 2, p. 264, Cambridge  
University Press, 1963.
138. J. B. Barbour, F. L. Warren and D. A. Wood,  
J. Chem. Soc., 1951, 2537.
139. R. Ikan, J. Kashman and E. D. Bergmann,  
J. Chromatog., 1964, 14, 275.
140. F. Arndt, Organic Syntheses, Coll. Vol. II,  
p. 165, J. Wiley and Sons, New  
York, 1944.

## Pimarane Diterpenes from *Cleistanthus schlechteri*

By H. A. Candy, Joan M. Pakshong, and K. H. Pegel,\* Chemistry Department, Natal University, Durban, South Africa

Reprinted from  
JOURNAL  
OF  
THE CHEMICAL SOCIETY

SECTION C  
Organic Chemistry

1970





*Source of Heartwood.*—Three trees of *Cleistanthus schlechteri* var. *Schlechteri*, Family Euphorbiaceae, were collected in the coastal region of Zululand, Natal, and botanical specimens of each were deposited in the Natal Herbarium, Durban, under the numbers 53049, 57826, and 60870. The light petroleum extracts of the milled heartwood from the three trees were shown to be identical by t.l.c.

*Extraction of the Three Pimarane Diterpenes (II), (V), and (VI).*—The milled heartwood (6.68 kg.) was soaked for 12 hr. at room temperature in light petroleum (8 l.) which was then evaporated under reduced pressure to yield an orange syrup (102 g.). Further exhaustive extraction of the wood with hot, light petroleum produced crude cleistanthol (I) (104 g., 1.55%) and a dark orange syrup (95 g.) identical in composition to the cold extract. The cold extract (15 g.) dissolved in light petroleum was applied to a basic aluminium oxide column; elution by the same solvent gave a fatty product (2.1 g.), and further elution with a mixture of benzene–light petroleum (1:1) afforded crystals of *ent-isopimara-8(14),15-dien-3 $\beta$ -ol* (II) (0.2 g.), which on repeated crystallisation gave colourless needles, m.p. 126–127°,  $[\alpha]_D +12.5^\circ$  (c 1) (Found: C, 83.1; H, 11.3.  $C_{20}H_{32}O$  requires C, 83.3; H, 11.2%), *m/e* 288 ( $M^+$ );  $\nu_{max}$ . 3325br, 3080, and 1631  $cm^{-1}$ ;  $\tau$  4.19 (1H, q, 15-H,  $J$  10 and 18 Hz), 4.75 (1H, s, 14-H), 5.10 (2H, m, 16-H), 6.73 (1H, m, 3-H), 8.95, 8.99, 9.17, and 9.19 (4  $\times$  3H, 4  $\times$  s, 4  $\times$  Me) {reported for *isopimara-8(14),15-dien-3 $\beta$ -ol*: m.p. 126.5–127.5°,  $[\alpha]_D -19.5^\circ$ ,<sup>2</sup> and the mass spectrum<sup>3</sup> and i.r. spectrum are identical to those given by (II)}. Addition of ethanol to the eluant (benzene–light petroleum–ethanol, 1:1:0.01) yielded crystals of *ent-3 $\beta$ -hydroxyisopimara-8(14),15-dien-12-one* (VI) (1.8 g.), which on recrystallisation from light petroleum–ethanol gave colourless prisms, m.p. 157–158°,  $[\alpha]_D +290^\circ$  (c 1) (Found: C, 79.3; H, 10.0.  $C_{20}H_{30}O_2$  requires C, 79.4; H, 10.0%), *m/e* 302 ( $M^+$ );  $\nu_{max}$ . 3547 (sharp), 3085, 1696, and 1628  $cm^{-1}$ ;  $\lambda_{max}$ . 300 (2.28) nm.;  $\tau$  4.25 (1H, q, 15-H,  $J_{obs}$  10 and 18 Hz), 4.76 (1H, s, 14-H), 4.89 (2H, m, 16-H), 6.76 (1H, m, 3-H), 8.78, 8.87, 9.20, and 9.29 (4  $\times$  3H, 4  $\times$  s, 4  $\times$  Me). On increasing the ethanol content of the above eluant (1:1:0.04) *ent-isopimara-8(14),15-dien-3 $\beta$ ,12 $\beta$ -diol* (V) (0.6 g.) was obtained, which crystallised as colourless, long spars, m.p. 161–162°,  $[\alpha]_D +28^\circ$  (c 1) (Found: C, 78.7; H, 10.8.  $C_{20}H_{32}O_2$  requires C, 78.9; H, 10.6%), *m/e* 304 ( $M^+$ );  $\nu_{max}$ . 3290br and 1635  $cm^{-1}$ ;  $\tau$  4.22 (1H, q, 15-H,  $J_{obs}$  10 and 18 Hz), 4.93 (3H, m, 14-H and 2  $\times$  16-H), 6.45 (1H, m, 12-H), 6.75 (1H, m, 3-H), 8.93, 8.98, 9.16, and 9.16 (4  $\times$  3H, 4  $\times$  s, 4  $\times$  Me). Further elution furnished a brown gum (6 g.) containing many constituents including cleistanthol.

*Acetylation Products.*—*ent-Isopimara-8(14),15-dien-3 $\beta$ -ol* (II) (0.1 g.) dissolved in a mixture of dry pyridine (6 ml.) and acetic anhydride (0.5 ml.) was set aside overnight and then poured into ice–water. The crude product gave on crystallisation needles of *ent-3 $\beta$ -acetoxisopimara-8(14),15-diene* (0.1 g.), m.p. 104–105°,  $[\alpha]_D -7^\circ$  (c 1) (Found: C, 79.9; H, 10.5.  $C_{22}H_{34}O_2$  requires C, 80.0; H, 10.4%), *m/e* 330 ( $M^+$ ) {reported for 3 $\beta$ -acetoxisopimara-8(14),15-diene: m.p. 102–104.5°,  $[\alpha]_D +4^\circ$ .<sup>2</sup>

*ent-3 $\beta$ -Hydroxyisopimara-8(14),15-dien-12-one* (VI) (0.2 g.) acetylated as described above, yielded on crystallisation colourless prisms of *ent-3 $\beta$ -acetoxisopimara-8(14),15-dien-12-one* (0.19 g.), m.p. 127–128°,  $[\alpha]_D +210.5^\circ$  (c 1) (Found:

C, 76.5; H, 9.4.  $C_{22}H_{32}O_3$  requires C, 76.7; H, 9.4%), *m/e* 344 ( $M^+$ ),  $\nu_{max}$ . 3078, 1723, 1700, and 1243  $cm^{-1}$ ,  $\tau$  4.25 (1H, q, 15-H,  $J_{obs}$  10 and 18 Hz), 4.74 (1H, s, 14-H), 4.89 (2H, m, 16-H), 5.50 (1H, m, 3-H), 7.96 (3H, s,  $CH_3COO$ ), 8.78, 9.10, 9.14, and 9.28 (4  $\times$  3H, 4  $\times$  s, 4  $\times$  Me).

*ent-Isopimara-8(14),15-dien-3 $\beta$ ,12 $\beta$ -diol* (V) (0.1 g.) acetylated as described above yielded, after crystallisation, needles of *ent-3 $\beta$ ,12 $\beta$ -diacetoxisopimara-8(14),15-diene* (0.1 g.), m.p. 117°,  $[\alpha]_D +33^\circ$  (c 1) (Found: C, 73.9; H, 9.4.  $C_{24}H_{36}O_4$  requires C, 74.2; H, 9.3%), *m/e* 388 ( $M^+$ ),  $\nu_{max}$ . 3095, 1733, 1721, and 1235  $cm^{-1}$ ;  $\tau$  4.39 (1H, q, 15-H,  $J_{obs}$  10 and 18 Hz), 4.85 (1H, s, 14-H), 5.05 (2H, m, 16-H), 5.19 (1H, overlapped, 12-H), and 5.48 (1H, m, 3-H).

*Oxime of Ketol* (VI).—*ent-3 $\beta$ -Hydroxyisopimara-8(14),15-dien-12-one* (VI) (0.1 g.) and hydroxylamine hydrochloride (0.2 g.) dissolved in a mixture of pyridine (10 ml.) and ethanol (10 ml.) were set aside for 24 hr. On dilution with water the oxime separated out. Crystallisation afforded cubes, m.p. 167–168°,  $[\alpha]_D +163^\circ$  (c 1) (Found:  $M^+$ , *m/e* 317.235202.  $C_{20}H_{31}NO_2$  requires  $M^+$ , *m/e* 317.235466).

*Oxidation Reactions.*—*ent-Isopimara-8(14),15-dien-3 $\beta$ -ol* (II) (0.1 g.) dissolved in acetone (5 ml.) was treated dropwise with Jones reagent (8N-chromic acid) until the solution remained orange-brown. The mixture was set aside at 5° for 1 hr. after which addition of ice water induced the deposition of crystals of *ent-isopimara-8(14),15-dien-3-one* (III) (80 mg.); recrystallisation gave long rods, m.p. 60°,  $[\alpha]_D +45^\circ$  (c 2) (Found: C, 83.6; H, 10.5.  $C_{20}H_{30}O$  requires C, 83.9; H, 10.6%), *m/e* 286 ( $M^+$ ),  $\nu_{max}$ . (CHCl<sub>3</sub>) 3078, 1697, and 1630  $cm^{-1}$ ;  $[\phi] +2810^\circ$  (peak, 315 nm.) and 0° (trough, 280 nm.). The compound gave a 2,4-dinitrophenylhydrazone, m.p. 177–178° (Found: C, 66.8; H, 7.6.  $C_{26}H_{34}N_4O_4$  requires C, 66.9; H, 7.4%) (reported for *isopimara-8(14),15-dien-3-one*: m.p. 59–60°,  $[\alpha]_D -56^\circ$ ; 2,4-dinitrophenylhydrazone, m.p. 176.5–177°).<sup>2</sup>

*ent-3 $\beta$ -Hydroxyisopimara-8(14),15-dien-12-one* (VI) (0.1 g.) oxidised as described above, yielded *ent-isopimara-8(14),15-dien-3,12-dione* (70 mg.) which crystallised as long spars, m.p. 84–85°,  $[\alpha]_D +312^\circ$  (c 1) (Found: C, 79.8; H, 9.6.  $C_{20}H_{28}O_2$  requires C, 80.0; H, 9.4%), *m/e* 300 ( $M^+$ ),  $\nu_{max}$ . 3078, 1695s, and 1625  $cm^{-1}$ ;  $\lambda_{max}$ . 236sh (2.48) and 295 nm. (2.32) with no change in basic solution.

*ent-Isopimara-8(14),15-dien-3 $\beta$ ,12 $\beta$ -diol* (V) oxidised as described above yielded the same 3,12-diketone, m.p. 84–85°.

*Catalytic Reductions.*—*ent-3 $\beta$ -Hydroxyisopimara-8(14),15-dien-12-one* (VI) (0.2 g.) in ethanol (20 ml.) over palladium-charcoal (50 mg., 30%) absorbed 14.1 ml. of hydrogen at N.T.P. (theor. for 1 mol. 12.8 ml.). Crystallisation of the product gave needles of *ent-3 $\beta$ -hydroxyisopimara-8(14)-en-12-one*, m.p. 114–115°,  $[\alpha]_D +76^\circ$  (c 1) (Found: C, 78.6; H, 10.6.  $C_{20}H_{32}O_2$  requires C, 78.9; H, 10.6%), *m/e* 304 ( $M^+$ ),  $\nu_{max}$ . 3542, 1712, 1695, and 1655  $cm^{-1}$ ,  $\lambda_{max}$ . 292 nm. (1.75);  $\tau$  4.70 (1H, s, 14-H) and 6.72 (1H, m, 3-H). Acetylation as described above yielded on crystallisation needles of *ent-3 $\beta$ -acetoxisopimara-8(14)-en-12-one*, m.p. 108–109°,  $[\alpha]_D +52^\circ$  (c 1) (Found: C, 76.2; H, 9.9.  $C_{22}H_{34}O_3$  requires C, 76.3; H, 9.9%), *m/e* 346 ( $M^+$ );  $\nu_{max}$ . 1725, 1700, and 1242  $cm^{-1}$ ,  $\tau$  4.76 (1H, s, 14-H) and 5.50 (1H, m, 3-H).

*ent-Isopimara-8(14),15-dien-3 $\beta$ ,12 $\beta$ -diol* (V) was hydrogenated over palladium-charcoal as described above. Crystallisation of the product gave needles of *ent-isopimara-8(14)-en-3 $\beta$ ,12 $\beta$ -diol*, m.p. 172–173°,  $[\alpha]_D -31^\circ$  (c 1) (Found: C, 74.6; H, 11.6.  $C_{20}H_{34}O_2 \cdot CH_3OH$  requires C, 74.5; H, 11.3%), *m/e* 306 ( $M^+$ ),  $\nu_{max}$ . 3300br  $cm^{-1}$ ;  $\tau$  4.88 (1H, s,

<sup>3</sup> H. E. Audier, S. Bory, M. Fetizon, and N-T. Anh, *Bull. Soc. chim. France*, 1966, 4002.



Handwritten text, possibly a signature or name, located at the top center of the page.

Vertical handwritten text on the right side of the page, possibly a list or notes.

Vertical handwritten text on the bottom center of the page.